



FEATURES

- Programmable DC feeding characteristics
- Programmable digital filters adapting to different requirements:
 - Impedance matching
 - Transhybrid balance
 - Transmit and receive gain adjustment
 - Frequency response correction
- Off-hook and ground-key detection
- AC/DC ring trip detection
- Programmable internal balanced ringing without external components
- Supports external ringing
- Selectable MPI and GCI interfaces
- Supports A/μ-law compressed and linear data formats
- Programmable IO pins with relay-driving or analog input capability
- Line polarity reversal
- Integrated FSK generator for sending Caller ID information
- On-hook transmission
- 2 programmable tone generators per channel
- Integrated Universal Tone Detection (UTD) unit for fax/modem tone detection
- Integrated Test and Diagnosis Functions (ITDF)
- Three-party conference
- Only battery and 3.3 V power supply needed
- IDT82V1074 package: 100 pin TQFP
IDT82V1671 / IDT82V1671A package: 28 pin PLCC

DESCRIPTION

The RSLIC-CODEC chipset is comprised of one four-channel programmable PCM CODEC (IDT82V1074) and four single-channel ringing SLICs (IDT82V1671 / IDT82V1671A). The chipset provides a total solution for line card designs. In addition to providing a complete software programmable solution for BORSCHT, additional functions such as FSK generator, Universal Tone Detection (UTD) unit, tone generators, ringing generator, Integrated Test and Diagnosis Functions (ITDF), line polarity reversal and three-party conference are integrated in to the chipset. The high integration of system functions reduces board space requirements of the line card and saves cost.

The chipset is fully programmable via a Microprocessor Interface (MPI) or a General Circuit Interface (GCI). In both MPI and GCI modes, the chipset supports A/μ-law companding format or linear data format.

Programmable digital filters on the chipset provide the necessary transmit and receive filtering to realize impedance matching, transhybrid balance, frequency response correction and transmit/receive gains adjustment. The full programmability optimizes the performance of line card products and allows one line card to adapt to different requirements worldwide.

The powerful Integrated Test and Diagnosis Functions (ITDF) accomplish necessary tests and measurements without external test equipment or relays. This brings convenience to system maintenance and diagnosis.

This chipset can be used in digital telecommunication applications such as VoIP, VoATM, PBX, CO and DLC etc.

CHIPSET FUNCTIONAL BLOCK DIAGRAM

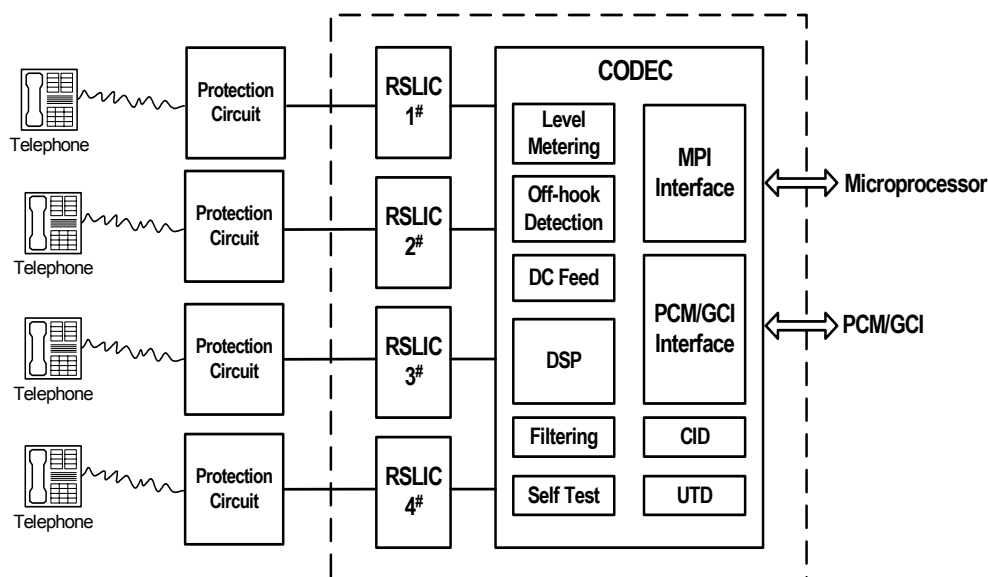

RSLIC FUNCTIONAL BLOCK DIAGRAM

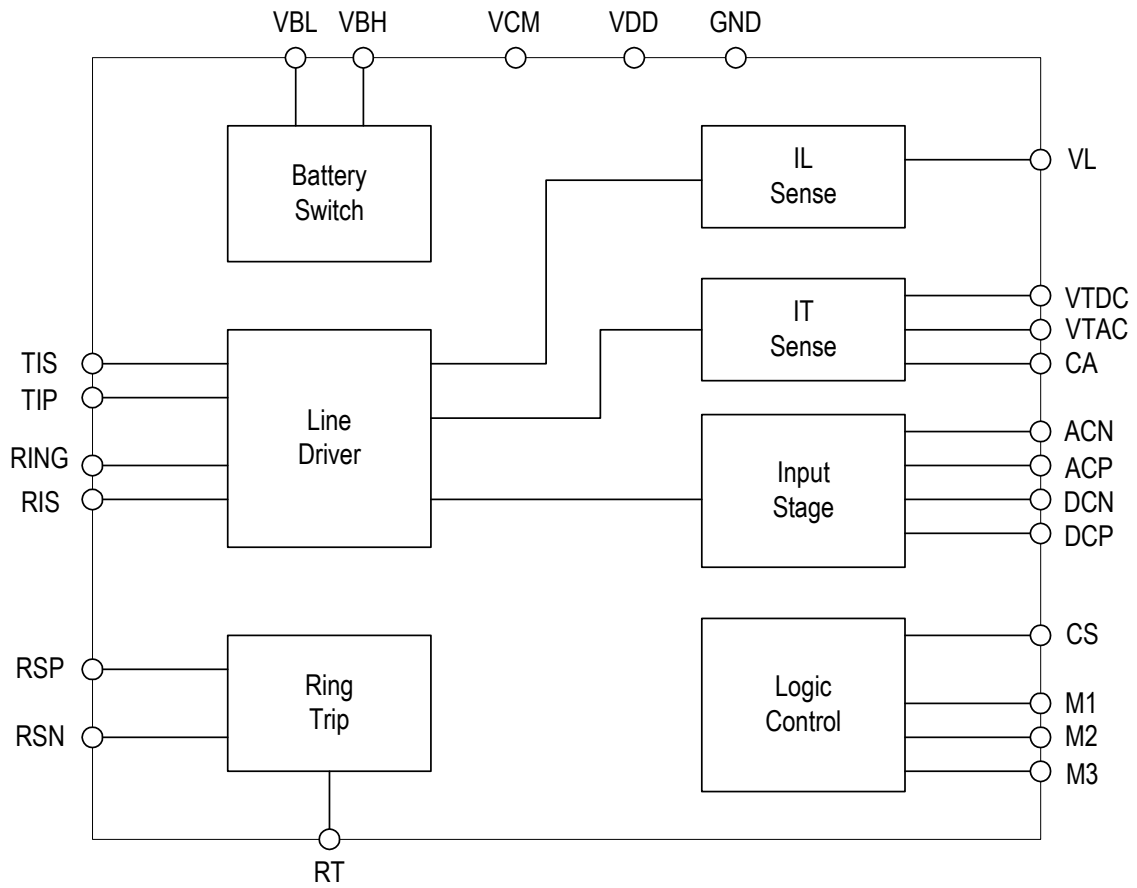

CODEC FUNCTIONAL BLOCK DIAGRAM

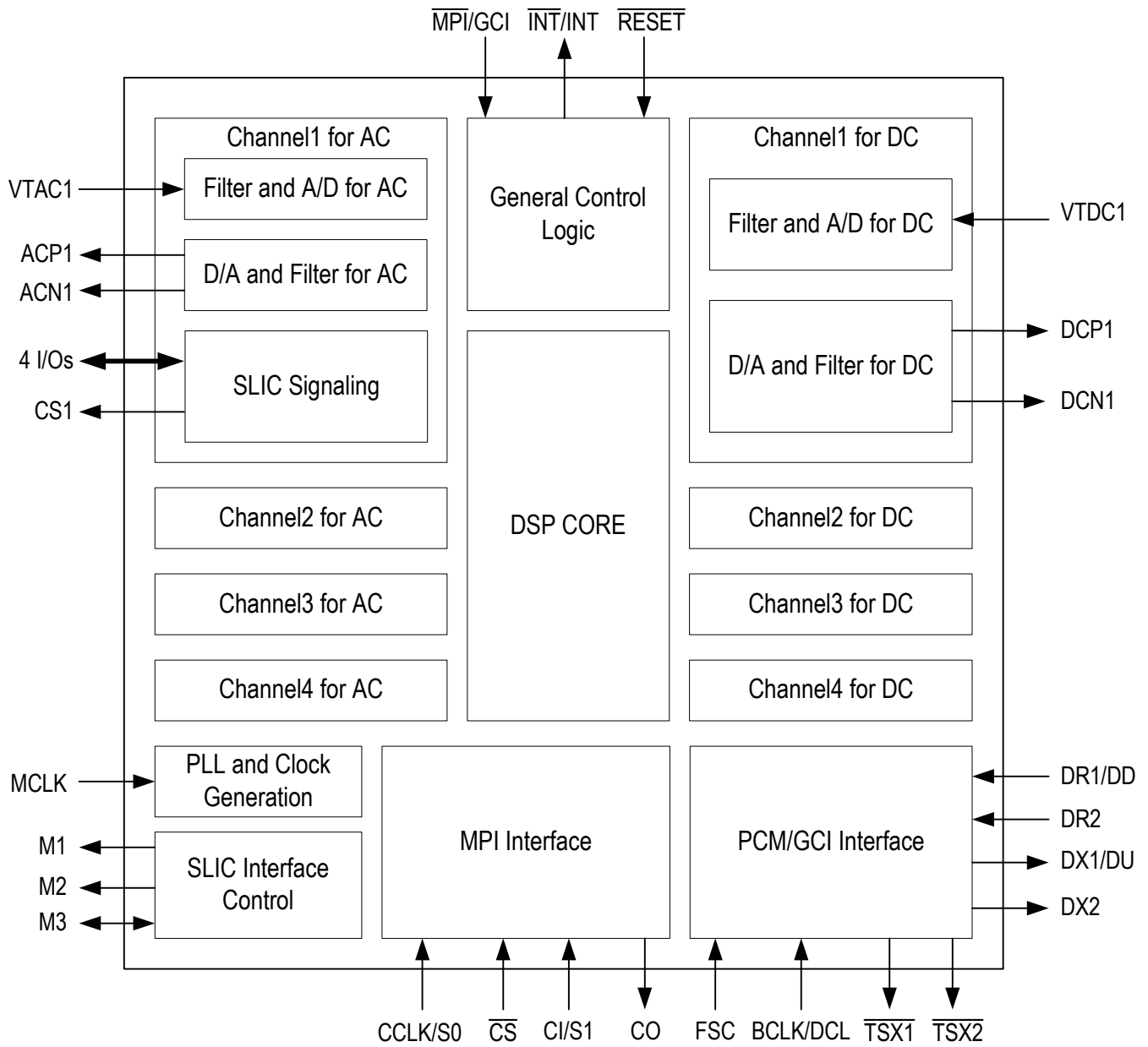

TABLE OF CONTENTS

1	Pin Configurations	9
1.1	RSLIC Pin Configuration	9
1.2	CODEC Pin Configuration	10
2	Pin Descriptions	11
2.1	RSLIC Pin Description	11
2.2	CODEC Pin Description	12
3	Functional Description	16
3.1	Functions Overview	16
3.1.1	Basic Functions	16
3.1.2	Additional Functions	16
3.1.3	Programmable Functions	16
3.2	DC Feeding	17
3.2.1	DC Feeding Characteristic Zones	17
3.2.2	Constant Current Zone	17
3.2.3	Resistive Zone	17
3.2.4	Constant Voltage Zone	17
3.2.5	DC Feeding Characteristics Configuration	18
3.3	Speech Processing	20
3.3.1	AC Transmission	20
3.3.1.1	Transmit Path	20
3.3.1.2	Receive Path	21
3.3.2	Programmable Filters	21
3.3.2.1	Impedance Matching	21
3.3.2.2	Transhybrid Balance	22
3.3.2.3	Frequency Response Correction	22
3.3.2.4	Gain Adjustment	22
3.4	Ring and Ring Trip	23
3.4.1	Internal Ringing Mode	23
3.4.1.1	Internal Ringing Generation	23
3.4.1.2	Ring Trip Detection In Internal Ringing Mode	23
3.4.2	External Ringing Mode	24
3.4.2.1	Ring Trip Detection In External Ringing Mode	25
3.5	Supervision	27
3.5.1	Off-hook Detection	27
3.5.2	Ground-Key Detection	29
3.6	Metering by Polarity Reversal	29
3.7	Enhanced Signal Processing	30
3.7.1	Tone Generator	30
3.7.1.1	DTMF Generation	30
3.7.2	FSK Generation for Caller ID	30
3.7.3	Universal Tone Detection (UTD)	34
3.7.3.1	Introduction	34
3.7.3.2	UTD Principle	34
3.7.3.3	UTD Programming	36
3.8	Three-Party Conference	37
3.8.1	Introduction	37
3.8.2	PCM Interface Configuration	37
3.8.3	Control the Active PCM Channels	38
3.9	ITDF	40
3.9.1	Introduction	40
3.9.2	Diagnosis and Test Functions	40
3.9.3	Integrated Signal Generators	40
3.9.4	Level Meter	40
3.9.4.1	Level Meter Source Selection	40

3.9.4.2	Level Meter Gain Filter and Rectifier	41
3.9.4.3	Level Meter Integrator	42
3.9.4.4	Level Meter Result Register	43
3.9.4.5	Level Meter Shift Factor	43
3.9.4.6	Level Meter Threshold Setting.....	43
3.9.5	Measurement via AC Level Meter	45
3.9.5.1	Current Measurement via VTAC.....	45
3.9.5.2	AC Level Meter Operational State Flow	45
3.9.6	Measurement via DC Level Meter	45
3.9.6.1	Offset Current Measurement	45
3.9.6.2	Leakage Current Measurement.....	45
3.9.6.3	Loop Resistance Measurement.....	46
3.9.6.4	Line Resistance Tip/GND and Ring/GND.....	46
3.9.6.5	Capacitance Measurement.....	47
3.9.6.6	Voltage Measurement	48
3.9.6.7	Voltage Offset Measurement.....	49
3.9.6.8	Ring Trip Operational Amplifier Offset Measurement.....	49
4	Interface	50
4.1	PCM/MPI Interface	50
4.1.1	MPI Control Interface	50
4.1.2	PCM Interface	51
4.1.2.1	PCM Clock Configuration	51
4.1.2.2	Time Slot Assignment.....	52
4.1.2.3	PCM Highway Selection	52
4.2	GCI Interface	52
4.2.1	Compressed GCI Mode.....	52
4.2.2	Linear GCI Mode	52
4.2.3	Command/Indication (C/I) Channel	55
4.2.3.1	Downstream C/I Channel Byte	55
4.2.3.2	Upstream C/I Channel Byte.....	55
4.2.4	GCI Monitor Transfer Protocol.....	56
4.2.4.1	Monitor Channel Operation	56
4.2.4.2	Monitor Handshake Procedure.....	56
4.3	Analog POTS Interface.....	58
4.4	RSLIC and CODEC Interface	58
5	Programming.....	59
5.1	Overview.....	59
5.1.1	MPI Programming	59
5.1.1.1	Broadcast Mode for MPI Programming	59
5.1.1.2	Identification Code for MPI Programming.....	59
5.1.2	GCI Programming	59
5.1.2.1	Program Start Byte for GCI Programming.....	59
5.1.2.2	Identification Command for GCI Programming.....	59
5.2	Register/RAM Commands.....	59
5.2.1	Register/RAM Command Format	59
5.2.2	Addressing the Local Registers.....	59
5.2.3	Addressing the Global Registers.....	60
5.2.4	Addressing the FSK-RAM	60
5.2.5	Addressing the Coe-RAM.....	61
5.3	Registers Description	63
5.3.1	Registers Overview	63
5.3.2	Global Registers List	65
5.3.3	Local Registers List.....	73
5.4	Programming Examples	83
5.4.1	Programming Examples for MPI Mode.....	83
5.4.1.1	Example of Programming the Local Registers via MPI	83

5.4.1.2	Example of Programming the Global Registers via MPI.....	84
5.4.1.3	Example of Programming the Coefficient-RAM via MPI.....	84
5.4.1.4	Example of Programming the FSK-RAM via MPI.....	84
5.4.2	Programming Examples for GCI Mode.....	85
5.4.2.1	Example of Programming the Local Registers via GCI.....	85
5.4.2.2	Example of Programming the Global Registers via GCI.....	85
5.4.2.3	Example of Programming the Coefficient-RAM via GCI.....	85
5.4.2.4	Example of Programming the FSK-RAM via GCI.....	86
6	Operational Description	87
6.1	Operating Modes.....	87
6.1.1	RSLIC Control Signaling.....	87
6.1.2	RSLIC Operating Modes.....	89
6.1.3	CODEC Operating Modes.....	89
6.2	PLL Power Down.....	90
6.3	Programmable I/Os of the CODEC.....	90
6.4	Interrupt Handling.....	91
6.5	Signal Path and Test Loopbacks.....	91
6.6	RSLIC Power On Sequence.....	93
6.7	CODEC Power On Sequence.....	93
6.8	Default State After Reset.....	93
6.8.1	Power-On Reset and Hardware Reset.....	93
6.8.2	Software Reset.....	93
7	Electrical Characteristics	94
7.1	RSLIC Electrical Characteristics.....	94
7.1.1	RSLIC Absolute Maximum Ratings.....	94
7.1.2	RSLIC Recommended Operating Conditions.....	94
7.1.3	RSLIC Thermal Information.....	94
7.1.4	RSLIC Power Consumption.....	94
7.2	CODEC Electrical Characteristics.....	95
7.2.1	CODEC Absolute Maximum Ratings.....	95
7.2.2	CODEC Recommended Operating Conditions.....	95
7.2.3	CODEC Digital Interface.....	95
7.2.4	CODEC Power Dissipation.....	95
7.3	Chipset Transmission Characteristics.....	96
7.3.1	Absolute Gain.....	96
7.3.2	Gain Tracking.....	96
7.3.3	Frequency Response.....	96
7.3.4	Return Loss.....	96
7.3.5	Group Delay.....	97
7.3.6	Distortion.....	97
7.3.7	Noise.....	97
7.3.8	Interchannel Crosstalk.....	98
7.4	CODEC Timing Characteristics.....	99
7.4.1	Clock Timing.....	99
7.4.2	Microprocessor Interface Timing.....	100
7.4.3	PCM Interface Timing.....	101
7.4.4	GCI Interface Timing.....	103
8	Application Circuits	104
8.1	Application Circuit for the Internal Ringing Mode.....	104
8.2	Application Circuit for the External Ringing Mode.....	105
9	Ordering Information	106

LIST OF FIGURES

Figure - 1	Line Circuit Functions Included in the RSLIC-CODEC Chipset	16
Figure - 2	DC Feeding Zones	17
Figure - 3	Constant Current Zone	17
Figure - 4	Resistive Zone	17
Figure - 5	Constant Voltage Zone	18
Figure - 6	DC Feeding Characteristics Configuration	18
Figure - 7	DC Feeding Configuration Example for Short Loop Applications	18
Figure - 8	Signal Paths for AC Transmission	20
Figure - 9	Voice Signal Path of the CODEC	20
Figure - 10	Nyquist Diagram	21
Figure - 11	Internal Balanced Ringing	23
Figure - 12	External Ringing Synchronization	25
Figure - 13	Hysteresis for Off-Hook Detection	27
Figure - 14	Debounce Filter for Off-hook/Ground-key Detection	28
Figure - 15	FSK Signal Transmission Sequence	31
Figure - 16	Recommended Programming Flow Chart for FSK Generation	33
Figure - 17	UTD Functional Diagram	34
Figure - 18	Example of UTD Recognition Timing	35
Figure - 19	Example of UTD Tone End Detection Timing	35
Figure - 20	Conference Block Diagram	37
Figure - 21	Level Meter Block Diagram	41
Figure - 22	Continuous Measurement Sequence (AC & DC Level Meter)	42
Figure - 23	Single Measurement Sequence (AC & DC Level Meter)	42
Figure - 24	Example for Resistance Measurement	46
Figure - 25	Differential Resistance Measurement	46
Figure - 26	Capacitance Measurement	47
Figure - 27	External Voltage Measurement Principle	48
Figure - 28	MPI Read Operation Timing	50
Figure - 29	MPI Write Operation Timing	50
Figure - 30	PCM Clock Slope Select Waveform	51
Figure - 31	Compressed GCI Frame Structure	53
Figure - 32	Linear GCI Frame Structure	54
Figure - 33	Monitor Channel Operation	56
Figure - 34	State Diagram of the Monitor Transmitter	57
Figure - 35	State Diagram of the Monitor Receiver	58
Figure - 36	Waveform of Programming Example: Writing to Local Registers	83
Figure - 37	Waveform of Programming Example: Reading Local Registers	83
Figure - 38	RSLIC Mode Control Signaling	87
Figure - 39	RSLIC Control Timing Diagram	88
Figure - 40	RSLIC Internal Test Circuit	89
Figure - 41	IO Debounce Filter	90
Figure - 42	AC/DC Signal Path and Test Loopbacks	92
Figure - 43	Clock Timing	99
Figure - 44	MPI Input Timing	100
Figure - 45	MPI Output Timing	100
Figure - 46	PCM Interface Timing (Single Clock Mode)	101
Figure - 47	PCM Interface Timing (Double Clock Mode)	102
Figure - 48	GCI Interface Timing	103
Figure - 49	Application Circuit for the Internal Ringing Mode	104
Figure - 50	Application Circuit for the External Ringing Mode	105

LIST OF TABLES

Table - 1	Registers and Coe-RAM Locations Used for DC Feeding Configuration	19
Table - 2	Registers and Coe-RAM Locations Used for Internal Ringing Mode	24
Table - 3	Registers and Coe-RAM Locations Used for External Ringing Mode	26
Table - 4	Off-hook Detection in Different Modes	27
Table - 5	Registers and Coe-RAM Locations Used for Off-hook Detection	28
Table - 6	Registers Used for Ground-key Detection.....	29
Table - 7	Registers and Coe-RAM Locations Used for Tone Generation	30
Table - 8	FSK Modulation Characteristics	31
Table - 9	Registers and FSK-RAM Used for the FSK Generator	32
Table - 10	Registers and Coe-RAM Locations Used for UTD	36
Table - 11	Conference Mode.....	38
Table - 12	Active PCM Channel Configuration Bits.....	38
Table - 13	Level Meter Source Selection	40
Table - 14	Level Meter Result Value Range.....	43
Table - 15	Shift Factor Selection	43
Table - 16	Level Meter Threshold Setting	43
Table - 17	Registers and Coe-RAM Locations Used for the Level Meter.....	44
Table - 18	Registers and Coe-RAM Locations Used for Ramp Generator.....	48
Table - 19	Time Slot Selection For Compressed GCI	53
Table - 20	Time Slot Selection For Linear GCI.....	54
Table - 21	Local Register Addressing in MPI Mode	60
Table - 22	Local Register Addressing in GCI Mode	60
Table - 23	Coefficient RAM Mapping.....	62
Table - 24	Global Registers Mapping	63
Table - 25	Local Registers Mapping.....	64
Table - 26	RSLIC Operating Mode	89
Table - 27	Interrupt Source and Interrupt Mask.....	91
Table - 28	External Components in Application Circuits	105

1 PIN CONFIGURATIONS

1.1 RSLIC PIN CONFIGURATION

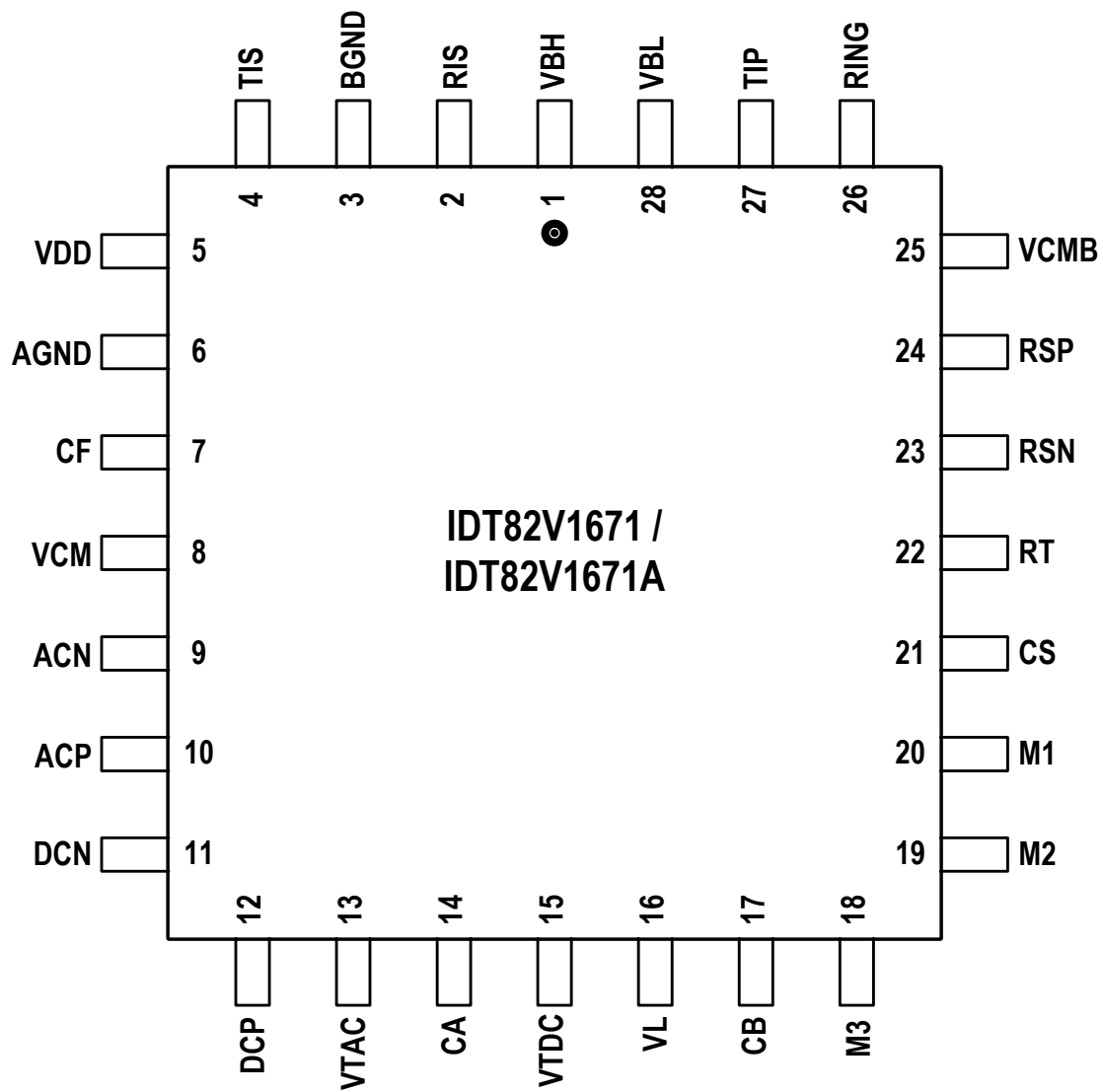

1.2 CODEC PIN CONFIGURATION

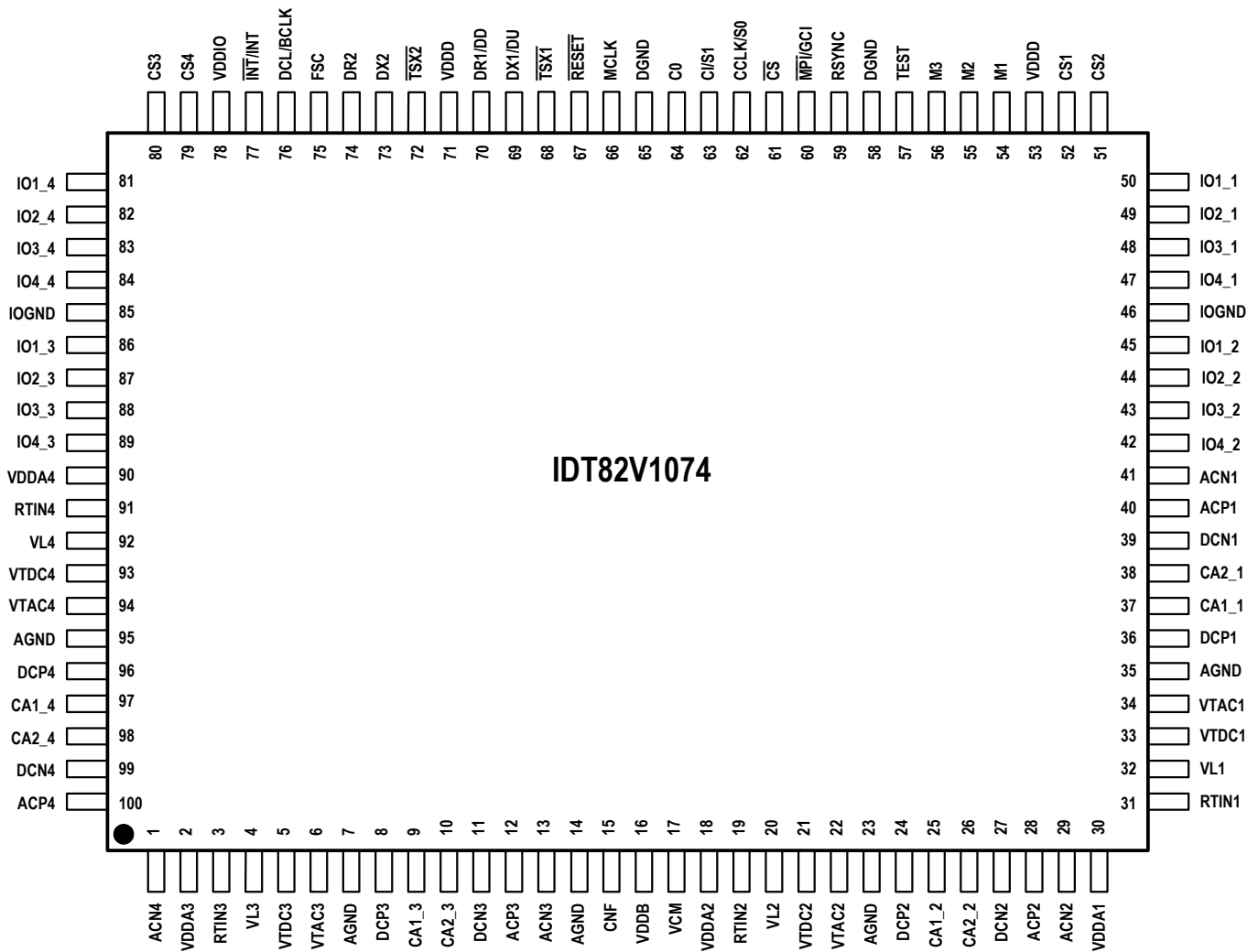

2 PIN DESCRIPTIONS

2.1 RSLIC PIN DESCRIPTION

Name	Type	Pin Number	Description
VBH	Power	1	Negative battery supply (for IDT82V1671: $-52\text{ V} \leq \text{VBH} \leq -20\text{ V}$; for IDT82V1671A: $-70\text{ V} \leq \text{VBH} \leq -52\text{ V}$)
RIS	–	2	Ring sense, connected to the RING pin through an external resistor RS. Refer to “8 Application Circuits” on page 104 for details.
BGND	Power	3	Battery ground. This pin should be externally connected to AGND.
TIS	–	4	Tip sense, connected to the TIP pin through an external resistor RS.
VDD	Power	5	+3.3 V power supply.
AGND	Power	6	Analog ground. This pin should be externally connected to BGND.
CF	O	7	Output voltage of VBAT/2 (VBAT represents the selected battery voltage VBH or VBL). An external capacitor is connected between this pin and the ground for filtering.
VCM	I	8	Reference voltage input, typical 1.5 V.
ACN	I	9	Differential AC voltage, negative.
ACP	I	10	Differential AC voltage, positive.
DCN	I	11	Differential DC voltage, negative.
DCP	I	12	Differential DC voltage, positive.
VTAC	O	13	Sense transversal AC voltage.
CA	–	14	External capacitor connection. An external capacitor is connected between this pin and the CB pin to separate the DC component from the sense transversal voltage.
VTDC	O	15	Sense transversal DC voltage.
VL	O	16	Sense longitudinal voltage.
CB	–	17	External capacitor connection. An external capacitor is connected between this pin and the CA pin to separate the DC component from the sense transversal voltage.
M3	I/O	18	Mode control input 3 or temperature information output. The logic level of the CS pin determines the direction of the M3 pin. See the description of the CS pin for details.
M2	I	19	Mode control input 2. This is a binary logic pin, together with M1 and M3, controlling the operating mode of the RSLIC.
M1	I	20	Mode control input 1. This is a binary logic pin, together with M2 and M3, controlling the operating mode of the RSLIC.
CS	I	21	Chip select input. It is a ternary logic pin. When the CS pin is logic 0 ($0\text{ V} < \text{CS} < 0.8\text{ V}$), the RSLIC receives the mode control data from the CODEC through the M1 to M3 pins. When the CS pin is logic 1 ($2.2\text{ V} < \text{CS} < 3.3\text{ V}$), the RSLIC sends the temperature information of itself to the CODEC through the M3 pin. When the CS pin is 1.5 V (with $\pm 0.5\text{ V}$ tolerance), the RSLIC neither receives the data from the CODEC nor sends temperature information to it.
RT	O	22	Ring trip operational amplifier output.
RSN	I	23	Negative ring trip operational amplifier input.
RSP	I	24	Positive ring trip operational amplifier input.
VCMB	O	25	VCM buffer output, 1.5 V, used for external ringing mode.
RING	I/O	26	Subscriber loop connection Ring.
TIP	I/O	27	Subscriber loop connection Tip.
VBL	Power	28	Negative battery supply (for both IDT82V1671 and IDT82V1671A: $-52\text{ V} \leq \text{VBL} \leq -20\text{ V}$) (Note that for IDT82V1671: $\text{VBH} \leq \text{VBL}$)

2.2 CODEC PIN DESCRIPTION

Name	Type	Pin Number	Description
VTDC1	I	33	DC component of the transversal voltage (Channel 1).
VTAC1	I	34	AC component of transversal voltage (Channel 1).
VL1	I	32	Longitudinal voltage (Channel 1).
RTIN1	I	31	Analog voltage that can be used for external ring trip detection (channel 1).
ACP1	O	40	Differential AC voltage, positive (Channel 1).
ACN1	O	41	Differential AC voltage, negative (Channel 1).
DCP1	O	36	Differential DC voltage, positive (Channel 1).
DCN1	O	39	Differential DC voltage, negative (Channel 1).
CS1	O	52	Ternary logic output 1, controlling the operating mode of the RSLIC1 (Channel 1). When the CS1 pin is logic 0 ($0\text{ V} < \text{CS1} < 0.8\text{ V}$), the CODEC sends mode control data to the RSLIC1 through the M1 to M3 pins. When the CS1 pin is logic 1 ($2.2\text{ V} < \text{CS1} < 3.3\text{ V}$), the CODEC receives the temperature information of the RSLIC1 through the M3 pin. When the CS1 pin is 1.5 V (with $\pm 0.5\text{ V}$ tolerance), no mode control data or temperature information is transferred between the CODEC and the RSLIC1.
IO1_1	I/O	50	Programmable IO pin with relay-driving capability (Channel 1). In external ringing mode, the IO1_1 pin can be used to control the external ring relay.
IO2_1	I/O	49	Programmable IO pin with relay-driving capability (Channel 1).
IO3_1	I/O	48	Programmable IO pin with analog input functionality (Channel 1).
IO4_1	I/O	47	Programmable IO pin with analog input functionality (Channel 1).
CA1_1	I/O	37	External capacitor connection. An external capacitor is connected between this pin and the DCP1 pin for filtering (Channel 1).
CA2_1	I/O	38	External capacitor connection. An external capacitor is connected between this pin and the DCN1 pin for filtering (Channel 1).
VTDC2	I	21	DC component of the transversal voltage (Channel 2).
VTAC2	I	22	AC component of the transversal voltage (Channel 2).
VL2	I	20	Longitudinal voltage (Channel 2).
RTIN2	I	19	Analog voltage that can be used for external ring trip detection (channel 2).
ACP2	O	28	Differential AC voltage, positive (Channel 2).
ACN2	O	29	Differential AC voltage, negative (Channel 2).
DCP2	O	24	Differential DC voltage, positive (Channel 2).
DCN2	O	27	Differential DC voltage, negative (Channel 2).
CS2	O	51	Ternary logic output 2, controlling the operating mode of the RSLIC2 (Channel 2). When the CS2 pin is logic 0 ($0\text{ V} < \text{CS2} < 0.8\text{ V}$), the CODEC sends mode control data to the RSLIC2 through the M1 to M3 pins. When the CS2 pin is logic 1 ($2.2\text{ V} < \text{CS2} < 3.3\text{ V}$), the CODEC receives the temperature information of the RSLIC2 through the M3 pin. When the CS2 pin is 1.5 V (with $\pm 0.5\text{ V}$ tolerance), no mode control data or temperature information is transferred between the CODEC and the RSLIC2.
IO1_2	I/O	45	Programmable IO pin with relay-driving capability (Channel 2). In external ringing mode, the IO1_2 pin can be used to control the external ring relay.
IO2_2	I/O	44	Programmable IO pin with relay-driving capability (Channel 2).
IO3_2	I/O	43	Programmable IO pin with analog input functionality (Channel 2).
IO4_2	I/O	42	Programmable IO pin with analog input functionality (Channel 2).
CA1_2	I/O	25	External capacitor connection. An external capacitor is connected between this pin and the DCP2 pin for filtering (Channel 2).
CA2_2	I/O	26	External capacitor connection. An external capacitor is connected between this pin and the DCN2 pin for filtering (Channel 2).

Name	Type	Pin Number	Description
VTDC3	I	5	DC component of the transversal voltage (Channel 3).
VTAC3	I	6	AC component of the transversal voltage (Channel 3).
VL3	I	4	Longitudinal voltage (Channel 3).
RTIN3	I	3	Analog voltage that can be used for external ring trip (channel 3).
ACP3	O	12	Differential AC voltage, positive (Channel 3).
ACN3	O	13	Differential AC voltage, negative (Channel 3).
DCP3	O	8	Differential DC voltage, positive (Channel 3).
DCN3	O	11	Differential DC voltage, negative (Channel 3).
CS3	O	80	Ternary logic output 3, controlling the operating mode of the RSLIC3 (Channel 3). When the CS3 pin is logic 0 ($0\text{ V} < \text{CS3} < 0.8\text{ V}$), the CODEC sends mode control data to the RSLIC3 through the M1 to M3 pins. When the CS3 pin is logic 1 ($2.2\text{ V} < \text{CS3} < 3.3\text{ V}$), the CODEC receives the temperature information of the RSLIC3 through the M3 pin. When the CS3 pin is 1.5 V (with $\pm 0.5\text{ V}$ tolerance), no mode control data or temperature information is transferred between the CODEC and the RSLIC3.
IO1_3	I/O	86	Programmable IO pin with relay-driving capability (Channel 3). In external ringing mode, the IO1_3 pin can be used to control the external ring relay.
IO2_3	I/O	87	Programmable IO pin with relay-driving capability (Channel 3).
IO3_3	I/O	88	Programmable IO pin with analog input functionality (Channel 3).
IO4_3	I/O	89	Programmable IO pin with analog input functionality (Channel 3).
CA1_3	I/O	9	External capacitor connection. An external capacitor is connected between this pin and the DCP3 pin for filtering (Channel 3).
CA2_3	I/O	10	External capacitor connection. An external capacitor is connected between this pin and the DCN3 pin for filtering (Channel 3).
VTDC4	I	93	DC component of the transversal voltage (Channel 4).
VTAC4	I	94	AC component of the transversal voltage (Channel 4).
VL4	I	92	Longitudinal voltage (Channel 4).
RTIN4	I	91	Analog voltage that can be used for external ring trip (Channel 4).
ACP4	O	100	Differential AC voltage, positive (Channel 4).
ACN4	O	1	Differential AC voltage, negative (Channel 4).
DCP4	O	96	Differential DC voltage, positive (Channel 4).
DCN4	O	99	Differential DC voltage, negative (Channel 4).
CS4	O	79	Ternary logic output 4, controlling the operating mode of the RSLIC4 (Channel 4). When the CS4 pin is logic 0 ($0\text{ V} < \text{CS4} < 0.8\text{ V}$), the CODEC sends mode control data to the RSLIC4 through the M1 to M3 pins. When the CS4 pin is logic 1 ($2.2\text{ V} < \text{CS4} < 3.3\text{ V}$), the CODEC receives the temperature information of the RSLIC4 through the M3 pin. When the CS4 pin is 1.5 V (with $\pm 0.5\text{ V}$ tolerance), no mode control data or temperature information is transferred between the CODEC and the RSLIC4.
IO1_4	I/O	81	Programmable IO pin with relay-driving capability (Channel 4). In external ringing mode, the IO1_4 pin can be used to control the external ring relay.
IO2_4	I/O	82	Programmable IO pin with relay-driving capability (Channel 4).
IO3_4	I/O	83	Programmable IO pin with analog input functionality (Channel 4).
IO4_4	I/O	84	Programmable IO pin with analog input functionality (Channel 4).
CA1_4	I/O	97	External capacitor connection. An external capacitor is connected between this pin and the DCP4 pin for filtering (Channel 4).
CA2_4	I/O	98	External capacitor connection. An external capacitor is connected between this pin and the DCN4 pin for filtering (Channel 4).

Name	Type	Pin Number	Description
M1	O	54	RSLIC operating mode control output 1. The M1 to M3 pins together with the CS _n pin (n = 1 to 4 for Channel 1 to 4 respectively) determine the operating mode of the RSLIC connected to Channel n of the CODEC. Refer to the description of the CS _n pin for details.
M2	O	55	RSLIC operating mode control output 2. See the description of the M1 pin for details.
M3	I/O	56	RSLIC operating mode control output 3 or RSLIC temperature information input. The direction of this pin is determined by the logic level of the CS _n pin (n = 1 to 4 for Channel 1 to 4 respectively): CS _n = 0: M3 is an output pin. It, together with M1 and M2, carries the mode control data to RSLIC _n ; CS _n = 1: M3 is an input pin, carrying the temperature information of RSLIC _n to the CODEC.
MPI/GCI	I	60	Interface mode selection. Logic 0 selects MPI mode and logic 1 selects GCI mode.
FSC	I	75	Frame Synchronization Clock for PCM or GCI interface. The FSC signal is 8 kHz, identifying the beginning of the PCM frame (MPI mode) or indicating the beginning of Time Slot 0 in GCI frame (GCI mode).
DCL/BCLK	I	76	PCM Bit Clock (BCLK) for MPI mode or Data Clock (DCL) for GCI mode. In MPI mode, the PCM data is transferred between the CODEC and the PCM highway, following the BCLK. The BCLK signal and the MCLK signal should be from the same clock source. The BCLK signal is required to be synchronous to the FSC. The frequency of the BCLK can be from 256 kHz to 8.192 MHz in steps of 64 kHz. In GCI mode, the DCL is either 2.048 MHz or 4.096 MHz. The internal circuit of the CODEC automatically monitors this input to determine which frequency is being used.
DX1/DU	O	69	Data Transmit PCM highway one (for MPI mode) or Data Upstream (for GCI mode). In MPI mode, the PCM data is transmitted to the PCM highway one (DX1) or two (DX2), following the BCLK. In GCI mode, the GCI data of all four channels is transmitted via the DU pin to the master device.
DR1/DD	I	70	Data Receive PCM highway one (for MPI mode) or Data Downstream (for GCI mode). In MPI mode, the PCM Data is received from PCM highway one (DR1) or two (DR2), following the BCLK. In GCI mode, the GCI data is received from the master device via the DD pin.
TSX1	O	68	Transmit Indicator for PCM highway one, open drain. This pin becomes low when the data is transmitted via DX1.
TSX2	O	72	Transmit Indicator for PCM highway two, open drain. This pin becomes low when the data is transmitted via DX2.
DX2	O	73	Data Transmit PCM highway two (for MPI mode). Refer to the description of the DX1 pin for details.
DR2	I	74	Data Receive PCM highway two (for MPI mode). Refer to the description of the DR1 pin for details.
CCLK/S0	I	62	Control Clock (CCLK) for MPI mode or Time Slot Selection 0 (S0) for GCI mode. In MPI mode, the CCLK pin provides clock for the serial control interface. The frequency of the CCLK can be up to 8.192 MHz. In GCI mode, the S0 together with Time Slot Selection 1 (S1) determines which time slot is used to transmit the voice or control data.
CO	O	64	Control Data Output (CO) for MPI mode.
CI/S1	I	63	Control Data Input (CI) for MPI mode or Time Slot Selection 1 (S1) for GCI mode. Refer to the description of the S0 pin for details.
CS	I	61	CODEC Chip Selection signal for MPI mode, active low.
MCLK	I	66	Master Clock input. The MCLK pin provides the clock for the DSP of the CODEC. The frequency of the MCLK can be 1.536 MHz, 1.544 MHz, 2.048 MHz, 3.072 MHz, 3.088 MHz, 4.096 MHz, 6.144 MHz, 6.176 MHz or 8.192 MHz. In MPI mode, the MCLK signal and the BCLK signal should be from the same clock source.
INT/INT	O	77	Interrupt output pin for MPI mode. The active level of this pin is programmable. If any of the active interrupts occurs, this pin will be set to active level, high or low. It is active low by default.
VCM	O	17	Reference voltage output. Typical 1.5 V.
RESET	I	67	Reset signal input. Active low.
RSYNC	I	59	External Ringing Synchronization signal. In external ringing mode, the synchronization signal provided by the external ringer is applied to the CODEC via this pin. The external relay can be switched on or off by the IO1 pin synchronously following the RSYNC.
TEST	I	57	Input pin for internal test purpose. This pin must be connected to the ground.
CNF	–	15	External capacitor connection. An external capacitor is connected between this pin and the AGND for noise filtering.
VDDA1 VDDA2 VDDA3 VDDA4	Power	30 18 2 90	+3.3 V analog power supply.
VDDD	Power	71, 53	+3.3 V digital power supply.

Name	Type	Pin Number	Description
VDDDB	Power	16	+3.3 V bias power supply.
VDDIO	Power	78	Power supply for IO pins.
AGND	Power	7, 14, 23, 35, 95	Analog ground.
DGND	Power	58, 65	Digital ground.
IOGND	Power	46, 85	Ground for IO pins.

3 FUNCTIONAL DESCRIPTION

3.1 FUNCTIONS OVERVIEW

3.1.1 BASIC FUNCTIONS

All BORSCHT functions are integrated in the RSLIC-CODEC chipset:

- Battery feeding
The chipset provides programmable DC feeding characteristics.
- Over voltage protection
Over voltage protection is realized by the RSLIC and additional protection circuits.
- Ringing
The chipset supports both internal and external ringing modes.
- Supervision (signaling)
The chipset supports off-hook and ground-key detection, DC and AC ring trip detection.
- Coding
Supports A/μ-law compressed code and linear code.
- Hybrid
Provides hybrid for 2/4-wire conversion.
- Testing
Supports integrated test and diagnostic functions (ITDF).

3.1.2 ADDITIONAL FUNCTIONS

Besides full BORSCHT functions, the following additional functions are also integrated in the RSLIC-CODEC chipset:

- Tone generators
The CODEC provides two tone generators (TG1 & TG2) per channel. The tone generators can be used to generate DTMF

signals, test tones, dial tones etc.

- FSK generator
The chipset provides a built-in FSK generator for sending Caller ID information.
- Universal Tone Detection (UTD)
The chipset provides a built-in UTD unit per channel to detect special tones in the receive or transmit path (fax and modem tones, for example)
- Line polarity reversal
The chipset supports teletax metering by reversing the polarity of the Tip/Ring voltage.

3.1.3 PROGRAMMABLE FUNCTIONS

The RSLIC-CODEC chipset provides a highly flexible programmable solution for line card designs. By programming the corresponding registers or coefficient RAM in the CODEC, users can design one line card to meet different requirements worldwide. That means, adjusting the receive/transmit gain and the transhybrid balance can be realized by software with a single hardware design.

The chipset provides many programmable functions including:

- DC feeding characteristics
- Impedance matching
- Transhybrid balance
- Frequency response correction in transmit and receive paths
- Gain in transmit and receive paths
- Off-hook and ground-key detect threshold and debounce interval
- AC and DC ring trip thresholds
- Internal ringing frequency, amplitude and DC ringing offset voltage
- Analog and digital test loopbacks

These functions are described in detail in the following chapters.

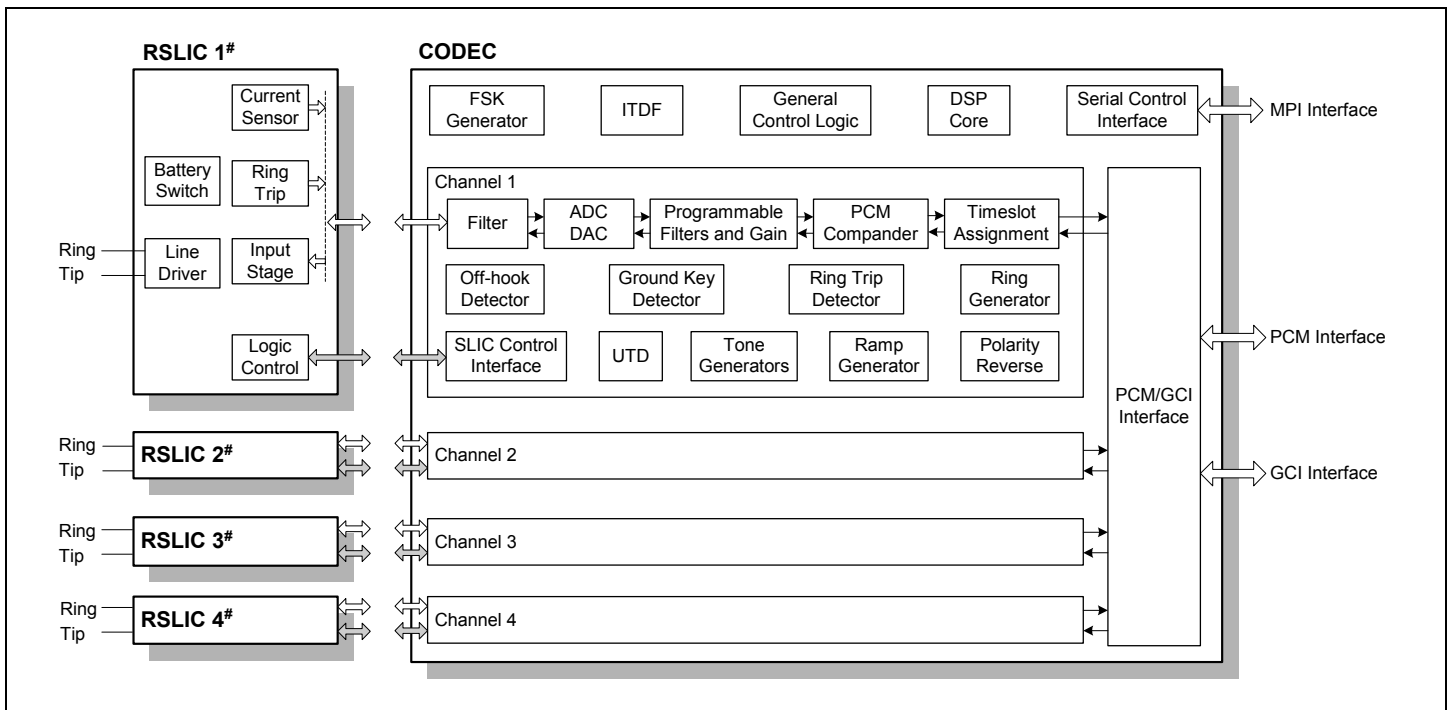

Figure - 1 Line Circuit Functions Included in the RSLIC-CODEC Chipset

3.2 DC FEEDING

3.2.1 DC FEEDING CHARACTERISTIC ZONES

Analog telephones require a DC current in the off-hook state with AC voice signals in the transmit and receive directions superimposed. Thus, once the telephone has gone off-hook, the SLIC must supply a DC current to the subscriber line. The RSLIC-CODEC chipset provides a fully programmable DC feeding characteristic to meet the requirements of different applications.

The DC feeding characteristic has three different zones: the constant current zone, the resistive zone and the constant voltage zone (see [Figure - 2](#)). A voltage reserve V_{RES} is provided to avoid clipping the high level AC signal.

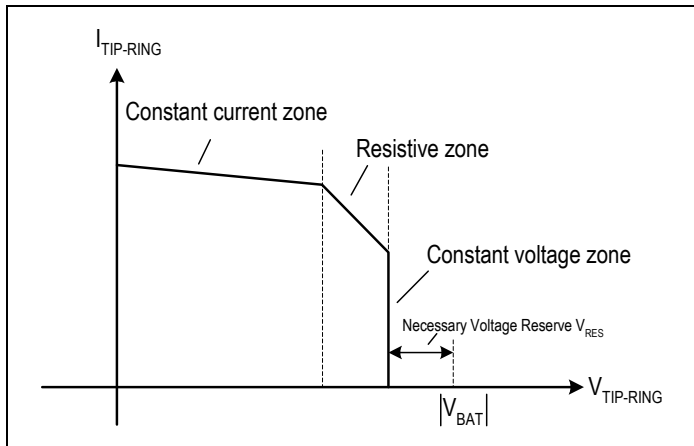

Figure - 2 DC Feeding Zones

3.2.2 CONSTANT CURRENT ZONE

In applications of short local loops, the DC feeding can be considered as an ideal current source with an infinite internal resistance (R_I), see [Figure - 3](#). When the loop is in the off-hook state, the feeding current usually must be kept at a constant level independent of the load. The RSLIC senses the DC current and provides this information to CODEC via the VTDC pin. The CODEC compares this value with the programmed value and adjusts the RSLIC drivers as required.

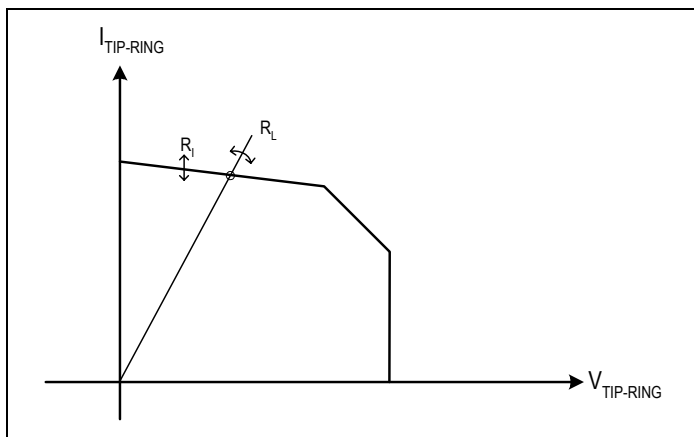

Figure - 3 Constant Current Zone

Depending on the load, the operating point is determined by the voltage $V_{Tip/Ring}$ between the Tip and Ring lines as follows:

$$V_{Tip/Ring} = R_L * I_{Tip/Ring}$$

Where, R_L represents the equivalent loop resistance. The lower the load resistance R_L , the lower the voltage $V_{Tip/Ring}$.

When the DC feeding is operating in the constant current zone, the indication bit FEED_I in register LREG21 will be set to 1, otherwise it is set to 0.

3.2.3 RESISTIVE ZONE

The resistive zone is flexible in a wide range of applications, especially applicable to medium line loops where the battery is unable to feed a constant current to the line. In this zone, the DC feeding is considered as a voltage source with a programmable internal resistance (R_{LIN}).

The operating point crosses from the constant current zone to the resistive zone, as shown in [Figure - 4](#).

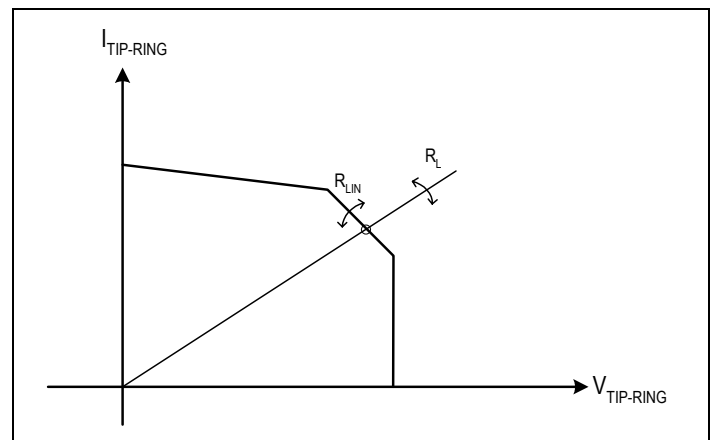

Figure - 4 Resistive Zone

When the DC feeding is operating in the resistive zone, the indication bit FEED_R in register LREG21 will be set to 1, otherwise it is set to 0.

3.2.4 CONSTANT VOLTAGE ZONE

In very high impedance loops (long loops), the DC feeding can be considered as a voltage source with zero internal resistance (R_V).

In this zone, the voltage $V_{Tip/Ring}$ is constant and the current $I_{Tip/Ring}$ depends on the load between the Tip and Ring lines. See [Figure - 5](#).

To avoid clipping the high level AC speech signals, a voltage reserve V_{RES} should be provided:

$$V_{RES} = |V_{BAT}| - V_{LIM}$$

Where, V_{BAT} is the selected battery voltage, V_{LIM} is the open circuit voltage.

Normally, $V_{RES} = 2 \text{ V}$.

When the DC feeding is operating at the constant voltage zone, the indication bit FEED_V in register LREG21 will be set to 1, otherwise it is set to 0.

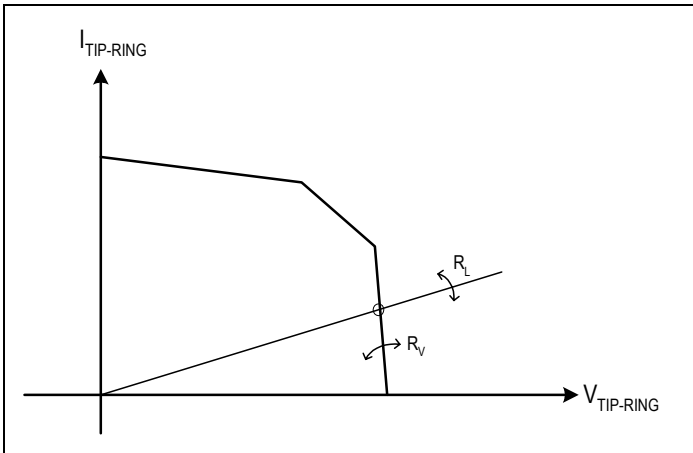

Figure - 5 Constant Voltage Zone

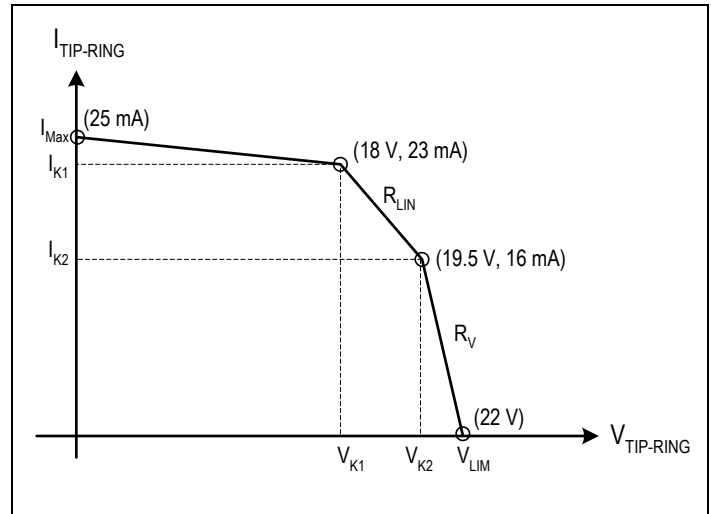

Figure - 6 DC Feeding Characteristics Configuration

3.2.5 DC FEEDING CHARACTERISTICS CONFIGURATION

The DC feeding characteristic is programmable. When the DC_FEED bit in register LREG5 is set to 1, the default DC feeding characteristic will be selected (see Figure - 6). The default configuration is typically for -24 V battery voltage application. When the DC_FEED bit is set to 0, the DC feeding characteristic is determined by the coefficients written in the Coe-RAM.

IDT provides a software (Cal74) that can calculate the coefficients for DC feeding. When users input the desired values for I_{MAX} , I_{K1} , V_{K1} , I_{K2} , V_{K2} and V_{LIM} , Cal74 will automatically calculate the DC feeding coefficients. When these coefficients are loaded to the Coe-RAM, the DC feeding characteristic will meet the requirements.

To reduce power consumption and make the DC loop stable, it is recommended to reduce I_{MAX} and keep the output resistance (R_L) less than 5 k Ω when the loop is operated in the constant current zone.

Here is an example for short loop applications (see Figure - 7):

Loop resistance < 600 Ω ;

I_{MAX} = 25 mA;

V_{K1} = 20 V;

I_{K1} = 20 mA (loop current requirement)

$$R_L = |(V_{K1} - 0)/(I_{K1} - I_{MAX})| = |(20 - 0)/(20 - 25)| = 4 \text{ k}\Omega$$

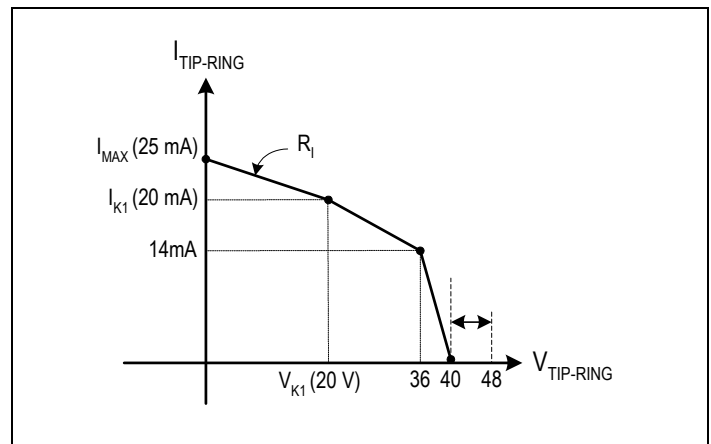

Figure - 7 DC Feeding Configuration Example for Short Loop Applications

Table - 1 lists the registers and the Coe-RAM locations used for DC feeding configuration. For more information about the Coe-RAM, please refer to "5.2.5 Addressing the Coe-RAM" on page 61 and Table - 23 on page 62.

Table - 1 Registers and Coe-RAM Locations Used for DC Feeding Configuration

Parameter	Register Bits/Coe-RAM Words	Notes
DC Feeding Coefficients Selection	Bit DC_FEED in LREG5	DC_FEED = 0: The DC feeding coefficient in the Coe-RAM is selected. DC_FEED = 1: The DC feeding coefficient in the ROM is selected (default);
Constant current zone indication	Bit FEED_I in LREG21	When the DC feeding is operating at the constant current zone, the FEED_I bit is set to 1, otherwise it is set to 0.
Resistive zone indication	Bit FEED_R in LREG21	When the DC feeding is operating at the resistive zone, the FEED_R bit is set to 1, otherwise it is set to 0.
Constant voltage zone indication	Bit FEED_V in LREG21	When the DC feeding is operating at the constant voltage zone, the FEED_V bit is set to 1, otherwise it is set to 0.
I_{Max}	DC Feeding Coefficients in the Coe-RAM	Programmable via the Coe-RAM. Programmable range: 0 to 50 mA with $\pm 7\%$ tolerance. Default value (in the ROM): 25 mA.
I_{K1}		Programmable via the Coe-RAM. Programmable range: 0 to 50 mA with $\pm 7\%$ tolerance. Default value (in the ROM): 23 mA.
V_{K1}		Programmable via the Coe-RAM. Programmable range: 0 to 48 V with $\pm 7\%$ tolerance. The default value (in the ROM): 18 V.
I_{K2}		Programmable via the Coe-RAM. Programmable range: 0 to 50 mA with $\pm 7\%$ tolerance. Default value (in the ROM): 16 mA.
V_{K2}		Programmable via the Coe-RAM. Programmable range: 0 to 48 V with $\pm 7\%$ tolerance. Default value (in the ROM): 19.5 V.
V_{LIM}		Programmable via the Coe-RAM. Programmable range: 0 to 48 V with $\pm 7\%$ tolerance. Default value (in the ROM): 22 V.

3.3 SPEECH PROCESSING

3.3.1 AC TRANSMISSION

The signal paths for AC transmission between the RSLIC and the CODEC is shown in Figure - 8. In the transmit direction, the transversal and longitudinal currents on the subscriber line are sensed by the RSLIC

and the corresponding voltages are fed to the CODEC via VTAC and VL pins. The voltage signals are further processed within the CODEC and finally transmitted to the PCM highway. In the receive direction, the CODEC processes data received from the PCM highway and outputs a differential analog signal to the RSLIC via the ACP and ACN pins. The RSLIC then amplifies this signal and applies it to the subscriber line.

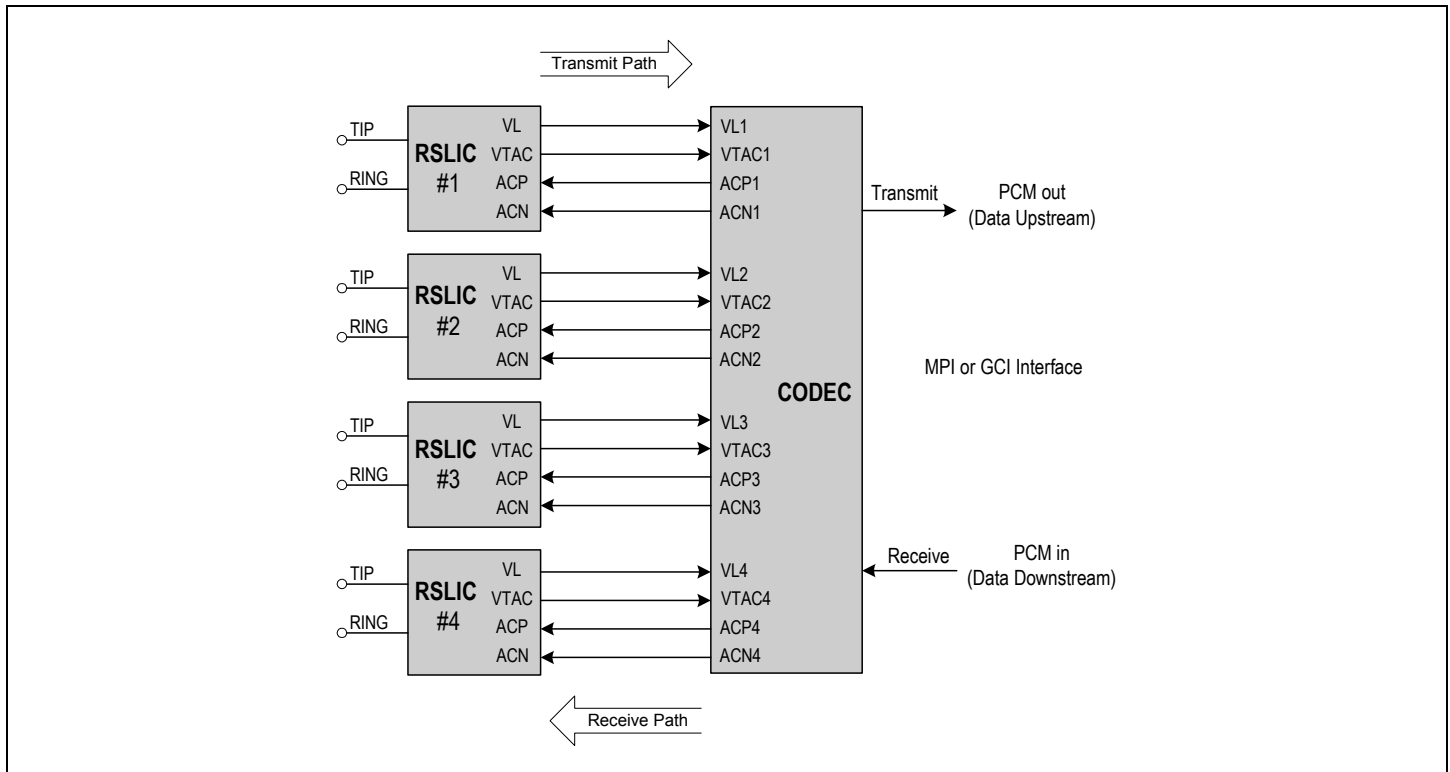

Figure - 8 Signal Paths for AC Transmission

3.3.1.1 Transmit Path

The voice signal path within the CODEC for one channel is shown in Figure - 9.

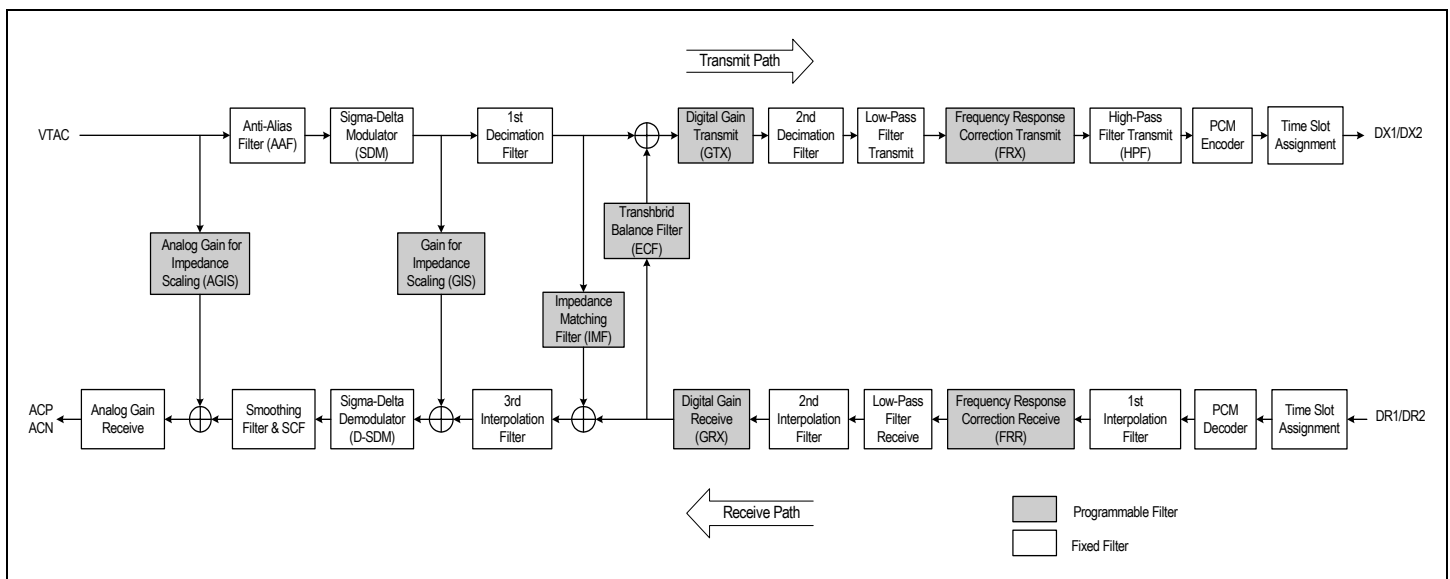

Figure - 9 Voice Signal Path of the CODEC

In the transmit path, the analog voltage from the RSLIC is first filtered by an anti-aliasing filter (AAF) and then is converted to a digital signal by a 1-bit sigma-delta modulator (SDM). The digital signal is down-sampled to an intermediate sample frequency to feed to the digital impedance matching filter (IMF). Simultaneously, the down-sampled signal is summed up with the output of the transhybrid balance filter (ECF). The sum signal is transmitted through the transmit gain filter (GTX) and further down-sampled to the baseband. A lowpass filter removes the unwanted signals to meet ITU-T requirements and a frequency response correction filter (FRX) follows to compensate for the attenuation brought up by the impedance matching loop. The final stage is a highpass filter (HPF) before the data is sent to the PCM encoder, where data is A-law or μ -law compressed. At last, the data is assigned to the selected time slot and transmitted to the PCM highway.

3.3.1.2 Receive Path

In the receive path, the signal received from the PCM highway is first passed through the time slot assignment stage before being expanded to a linear code at the baseband frequency of 8 kHz by the PCM decoder. The expanded data is then up-sampled to a higher frequency before passing through the frequency response correction filter (FRR) that compensates for the attenuation brought up by the impedance matching loop. The compensated signal is filtered by a lowpass filter and further up-sampled to the intermediate frequency. The signal is then sent to the receive gain filter (GRX). The output of the GRX goes in two ways: one feeds to the transhybrid balance filter (ECF) and the other sums up with the output of the digital impedance matching filter (IMF). This sum is then up-sampled and processed by a digital sigma-delta demodulator (D-SDM). An analog filter smooths the signal and outputs it to the RSLIC via the ACP and ACN pins.

3.3.2 PROGRAMMABLE FILTERS

A comprehensive multi-rate signal process scheme with fixed/programmable filters is applied to the AC loop of the RSLIC-CODEC chipset to optimize the performance of the line card. In addition to fully complying with the ITU-T G.712 specifications, the chipset also provides additional programmable analog/digital filters to match impedance, balance transhybrid, correct frequency response and adjust gains. All of the coefficients of the digital filters can be calculated automatically by a software (Cal74) provided by IDT. When these coefficients are written to coefficient RAM, the final AC transmission characteristics of the line card will meet ITU-T specifications.

Figure - 9 shows the programmable filters in the transmit and receive paths.

3.3.2.1 Impedance Matching

For the RSLIC-CODEC chipset, impedance matching is realized with three feedback loops in each channel: one analog loopback, the AGIS (Analog Gain for Impedance Scaling) stage, and two digital loopbacks in the programmable filters stage GIS (Gain for Impedance Scaling) and IMF (Impedance Matching Filter). See Figure - 9 for details. The analog loopback realizes the real part value ($\text{Re } Z_L$) of the impedance, while the digital loopbacks realize the imaginary part value ($\text{Im } Z_L$) of the impedance. The GIS and IMF filter loops operate at 2 MHz and 64 kHz rate respectively.

By programming the filters AGIS, GIS and IMF, the AC impedance of the chipset can be set to any value inside the shadowed area in Figure - 10.

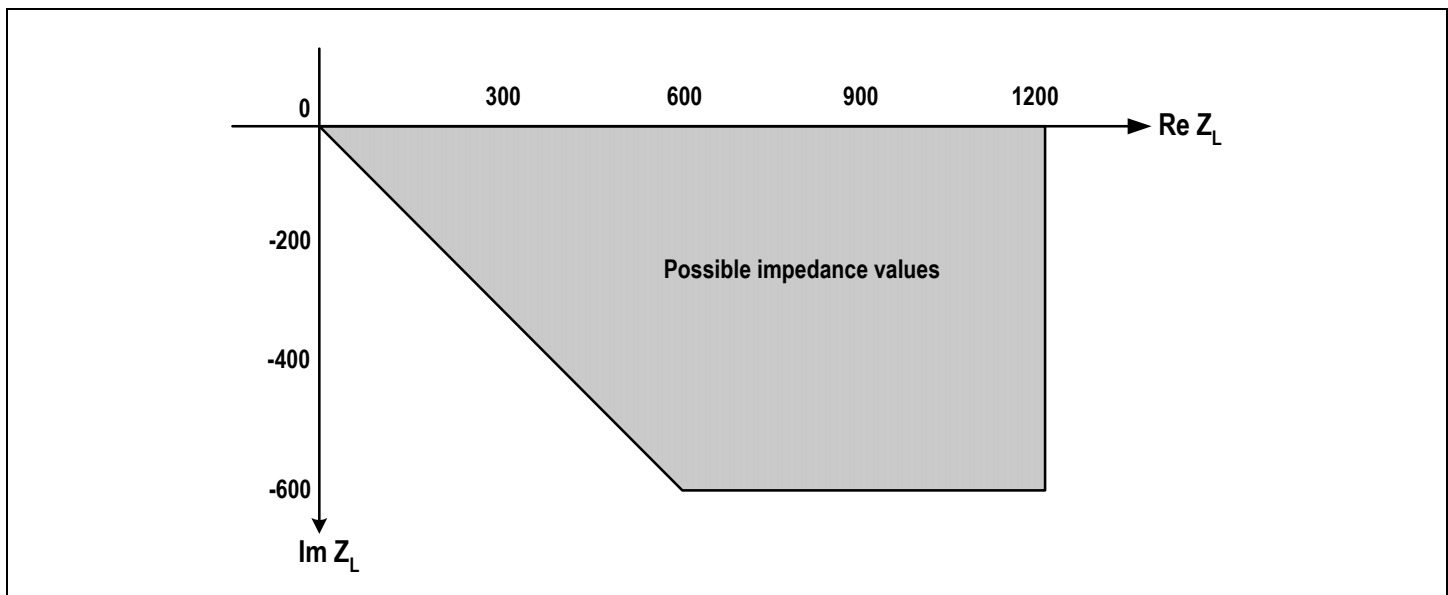

Figure - 10 Nyquist Diagram

The analog gain for impedance scaling (AGIS) can be 600 Ω or 900 Ω , as selected by the IM_629 bit in register LREG7. The option of AGIS=600 Ω is only applicable to loops with 600 Ω equivalent impedance, while the option of AGIS=900 Ω is applicable to all loops including those with 600 Ω equivalent impedance. The AGIS value is set to 600 Ω by default.

The coefficient for the GIS filter is programmed by Gain for Impedance Scaling in the Coe-RAM. It is programmable from -128 to +127 at increment of 1. The default value is 0.

If the IMF bit in LREG4 is set to 1, the IMF filter is disabled. If the IMF bit is set to 0, the Impedance Matching Filter Coefficient in the Coe-RAM is used by the IMF filter. Refer to [Table - 23 on page 62](#) for the Coefficient RAM Mapping.

3.3.2.2 Transhybrid Balance

The RSLIC-CODEC chipset provides a traditional transhybrid balance filter (ECF) for each channel to improve 4-wire return loss performance. The ECF coefficient is programmable. If the ECF bit in register LREG4 is set to 1, the ECF filter is disabled. If the ECF bit is set to 0, the Transhybrid Balance Filter Coefficient in the Coe-RAM is used.

3.3.2.3 Frequency Response Correction

The frequency response correction filters are used to compensate for the frequency distortion caused by the impedance matching filter. The

chipset provides two frequency response correction filters per channel: one is in the transmit path (FRX), the other is in the receive path (FRR).

The FRX bit in LREG4 determines whether the FRX filter is disabled or programmed by the Coe-RAM. If the FRX bit is set to 1, the FRX filter is disabled. If the FRX bit is set to 0, the Coefficient for Frequency Response Correction in the Transmit Path in the Coe-RAM is used.

The FRR bit in LREG4 determines whether the FRR filter is disabled or programmed by the Coe-RAM. If the FRR bit is set to 1, the FRR filter is disabled. If the FRR bit is set to 0, the Coefficient for Frequency Response Correction in the Receive Path in the Coe-RAM is used.

3.3.2.4 Gain Adjustment

For each channel, the gain in the transmit path is adjusted by programming the digital filter GTX. The transmit gain can be up to +12 dB in minimum steps of 0.05 dB. If the GTX bit in LREG4 is set to 1, the default transmit gain of 0 dB is selected. If the GTX bit is set to 0, the transmit gain is programmed via the Coe-RAM.

For each channel, the gain in the receive path consists of analog gain and digital gain (GRX). The analog gain is fixed at 0 dB. The digital gain is programmable from -12 dB to +3 dB in minimum steps of 0.05 dB. If the GRX bit in LREG4 is set to 1, the digital gain in the receive path will be 0 dB (default value), otherwise, it is programmed via the Coe-RAM.

3.4 RING AND RING TRIP

The RSLIC-CODEC chipset supports both internal and external ringing modes to meet different requirements.

3.4.1 INTERNAL RINGING MODE

3.4.1.1 Internal Ringing Generation

The chipset provides a built-in ring generator per channel that can generate balanced sinusoidal ringing signal without external components. The frequency, amplitude and DC offset of the ringing signal are programmable. In addition, the ring trip detection can be performed internally by programming the ring trip threshold.

If internal ringing mode is selected, the RSLIC will be automatically switched to the higher battery (VBH) for ringing generation. The ringing signal generated by the CODEC is sent to the RSLIC via the DCP and

DCN pins and further fed to the subscriber line by the RSLIC. Refer to [Figure - 49 on page 104](#) for an application circuit using internal ringing.

To generate a ringing signal, users should first set the operating mode to Internal Ringing (the CODEC is set to the RING mode and the RSLIC is set to Internal Ringing mode, refer to [Table - 3](#) for details). Next, calculate the coefficients of the ringing frequency, amplitude and DC offset and load the coefficients to the Coe-RAM (the calculation is performed by a software (Cal74) provided by IDT. When users input the frequency, amplitude and offset values, Cal74 will calculate the coefficients automatically). Then, the ringing generation will be controlled by the RING_EN bit in LREG7. In order to reduce noise and crosstalk on adjacent lines, the ringing signal will automatically start at a zero-crossing after the RING_EN bit is set to 1 and stop at zero-crossing after the RING_EN bit is set to 0.

[Figure - 11](#) shows a balanced ringing signal generated by the chipset.

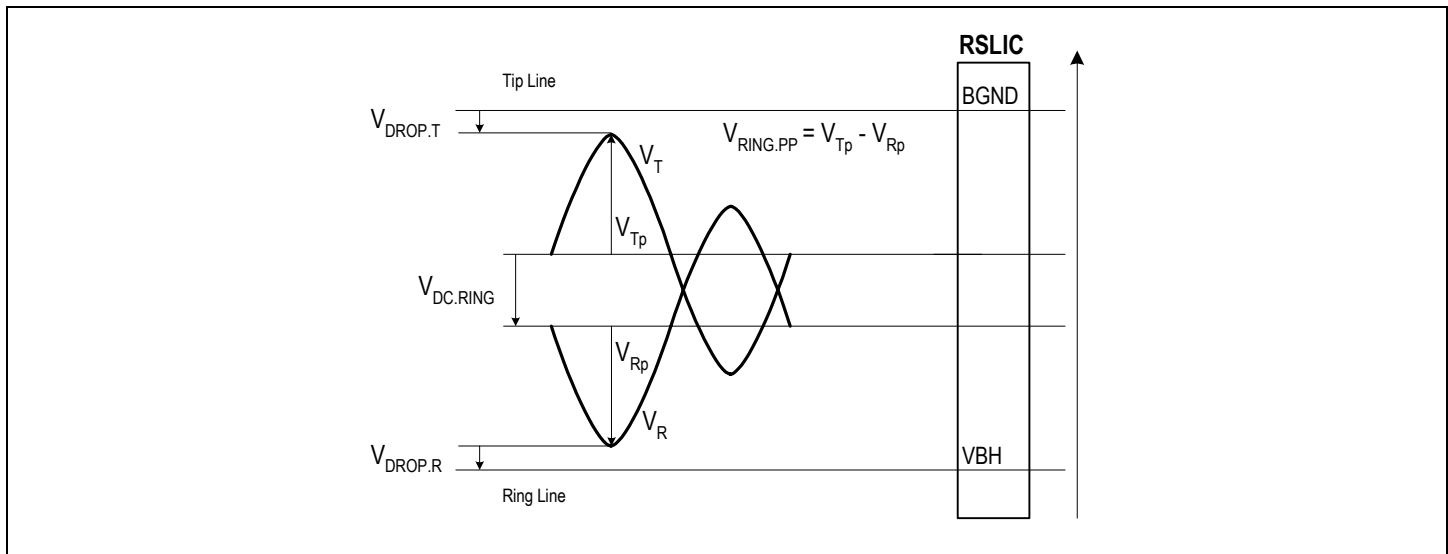

Figure - 11 Internal Balanced Ringing

3.4.1.2 Ring Trip Detection In Internal Ringing Mode

Once the subscriber has switched from on-hook state to off-hook state during ringing, the ringing signal must be removed from the subscriber line before normal speech begins. The recognition of an off-hook state during ringing, together with the removal of the ringing signal, is commonly referred to as ring trip. Depending on the application requirements, the RSLIC-CODEC chipset offers two different ring trip methods for internal ringing mode, they are DC ring trip detection and AC ring trip detection, as selected by the RT_SEL bit in LREG7.

- **DC Ring Trip Detection**

Most applications use DC ring trip detection. By applying a DC offset voltage together with the ringing signal, a transversal DC loop current starts to flow when the subscriber goes off-hook. The RSLIC senses the DC current and supplies the corresponding sensed voltage to the CODEC via the VTAC pin. The CODEC continuously integrates this voltage over one ringing period without rectifying. The result represents the DC component of the ring current. If the DC component exceeds the programmed DC ring trip threshold, the corresponding HK[n] bit (n = 0 to 3 are for Channel 1 to 4 respectively) in register GREG26 will be set to 1 to indicate that the loop has been off-hook. An interrupt will be generated

simultaneously if the corresponding mask bit HK_M[n] is set to 0.

Most of the applications use DC ring trip detection because it is very reliable. Even with very long and noisy lines the off-hook condition can reliably be detected within two ringing period by the DC ring trip. The DC ring trip method is selected by setting the RT_SEL bit in LREG7 to 1. The DC offset voltage is programmed by the RingOffset in the coefficient RAM. See [Table - 2](#) for detailed information.

In DC ring trip mode, when an off-hook event is detected, the ringing signal will stop immediately at zero-crossing. But the RING_EN bit will not be cleared to 0 automatically; it should eventually be cleared by software. This automatic ring trip function speeds up the response to off-hook for time critical applications.

- **AC Ring Trip Detection**

For short loop applications, the DC offset can be removed from the ringing signal to increase the achievable voltage amplitude for a given supply voltage. The AC ring trip detection without DC offset is realized by rectifying sensed ring current signal, integrating it over one ringing signal period and comparing the result with the programmed AC ring trip threshold. If the threshold is exceeded, the corresponding bit HK[n] (n = 0 to 3 are for Channel 1 to 4 respectively) in register GREG26 will be set

to 1 to indicate off-hook detected. An interrupt will be generated if the HK[n] bit is not masked.

Note that during a ring pause period, the off-hook condition can not be detected by the AC ring trip. When the off-hook condition is detected during a ring burst period, the ringing signal will be removed automatically at zero-crossing. As the RING_EN bit remains unchanged, users should clear it to 0 by software.

If several telephones are in parallel with each other between the Tip

and Ring lines, the on-hook AC current will increase. If the AC load is too large, the on-hook current of short loop will be larger than the off-hook current of long loop - this will possibly cause a false indication of the off-hook condition. Consequently, the AC ring trip detection method should only be used in short loops (loop impedance < 1 k Ω) and low-power applications.

Table - 2 lists the programmable parameters used for internal ringing generation and ring trip detection.

Table - 2 Registers and Coe-RAM Locations Used for Internal Ringing Mode

Parameter	Register Bits/Coe-RAM Words	Notes
Internal Ringing Mode Selection	MPI mode: bit RING in LREG7, bits SCAN_EN and SM[2:0] in LREG6; GCI mode: bit RING in LREG7, bits SCAN_EN and SM[2:0] in downstream C/I channel byte.	RING = 1: the CODEC is set to Ring mode SCAN_EN = 1 and SM[2:0] = 010: the RLSIC is set to Internal Ringing mode.
Internal Ringing Enable	Bit RING_EN in LREG7	RING_EN = 0: ring pause; RING_EN = 1: ring burst.
Internal Ringing Parameters Selection	Bit RG in LREG5	RG = 0: ringing parameters in the Coe-RAM are selected. RG = 1: ringing parameters (frequency, amplitude and offset) in the ROM are selected (default);
Internal Ringing Frequency	Word RingFreq in the Coe-RAM	Programmable via the Coe-RAM. Programmable range: 20 to 200 Hz with $\pm 3\%$ tolerance. Default value (in the ROM): 30 Hz.
Internal Ringing Amplitude	Word RingAmp in the Coe-RAM	Programmable via the Coe-RAM. Programmable range: 0 to 70 Vp with $\pm 1\%$ tolerance. Default value (in the ROM): 40 Vp.
Internal Ringing Offset Voltage	Word RingOffset in the Coe-RAM	Programmable via the Coe-RAM. Programmable range: 0 to 20 V with $\pm 1\%$ tolerance. Default value (in the ROM): 7 V.
Ring Trip Method Selection	Bit RT_SEL in LREG7	RT_SEL = 0: AC ring trip is selected; RT_SEL = 1: DC ring trip is selected.
Ring Trip Threshold Selection	Bit Signaling in LREG5	Signaling = 0: The AC and DC ring trip thresholds in the Coe-RAM are selected; Signaling = 1: The AC and DC ring trip thresholds in the ROM are selected (default);
AC Ring Trip Threshold	Word RTthld_AC in the Coe-RAM	Programmable via the Coe-RAM. Programmable range: 0 to 20 mA with $\pm 5\%$ tolerance. Default value (in the ROM): 5 mA.
DC Ring Trip Threshold	Word RTthld_DC in the Coe-RAM	Programmable via the Coe-RAM. Programmable range: 0 to 20 mA with $\pm 5\%$ tolerance. Default value (in the ROM): 5 mA.
Ring Trip Detection Result Indication	Bits HK[n] in GREG26	Indicating the ring trip detection result, '0' means Channel n+1 is on-hook while '1' means Channel n+1 is off-hook (n = 0 to 3)

3.4.2 EXTERNAL RINGING MODE

The chipset can generate internal ringing signals of up to 70 Vp. In applications of requiring higher ring amplitudes, external ringing signals can be used. Figure - 50 on page 105 shows an application circuit that use an external ringing signal.

If the RSLIC is set to External Ringing mode (see Table - 3 for details), the ringing signal from an external ring generator will be switched to the Tip/Ring lines through an external relay during ring burst period, and will be removed during ring pause period.

The CODEC provides two programmable IO pins (IO1 and IO2) with relay-driving capability for each channel. They can be used to control the external ring relay without additional components. The external ringing can be switched on/off in two different modes as described below:

- Synchronous mode (this mode is available when the IO1 pin is selected to control the external ring relay). In this mode, the external ringer provides a synchronous signal for the CODEC via the RSYNC pin to ensure switching the ringing signal at zero-crossing. This synchronous mode is enabled by setting the SYNC_EN bit in LREG19 to 1. When the IO1 pin of the CODEC is configured as an output (LREG20:

IO_C[0] = 1), the external ringing signal will be switched on the RSYNC edge (rising or falling) next to the change of the IO1 pin, as illustrated in Figure - 12. The logic level of the IO1 pin is set by the IO[0] bit in LREG20:

IO[0] = 0: IO1 pin is set to logic low;

IO[0] = 1: IO1 pin is set logic high.

In synchronous mode, the CODEC provides a hardware ring trip function to speed up the response of off-hook event. For example, if a logic low on the IO1 pin starts the ringing while a logic high on this pin stops the ringing, once an off-hook event is detected during ring burst period, the IO1 pin will be set to logic high automatically to remove the ringing signal although the IO[0] bit remains 0. Users should set the IO[0] bit to 1 by software.

- Asynchronous mode. If no synchronous signal is applied to the RSYNC pin of the CODEC, or some applications need to switch the ringing signal without any delay caused by zero-crossing synchronization, the SYNC_EN bit in LREG19 should be set to 0. In this case, the external ringing signal will be switched immediately after the corresponding IO pin control bit (IO[0] for the IO1 pin and IO[1] for the

IO2 pin) in LREG20 is changed, irrespective of whether the ringing signal is at a zero-crossing or not. In this mode, even if the IO1 pin is used to control the ring relay, it will act as a normal IO pin. In other

words, the hardware ring trip function is no longer available and the IO1 pin is controlled completely by software through the CODEC.

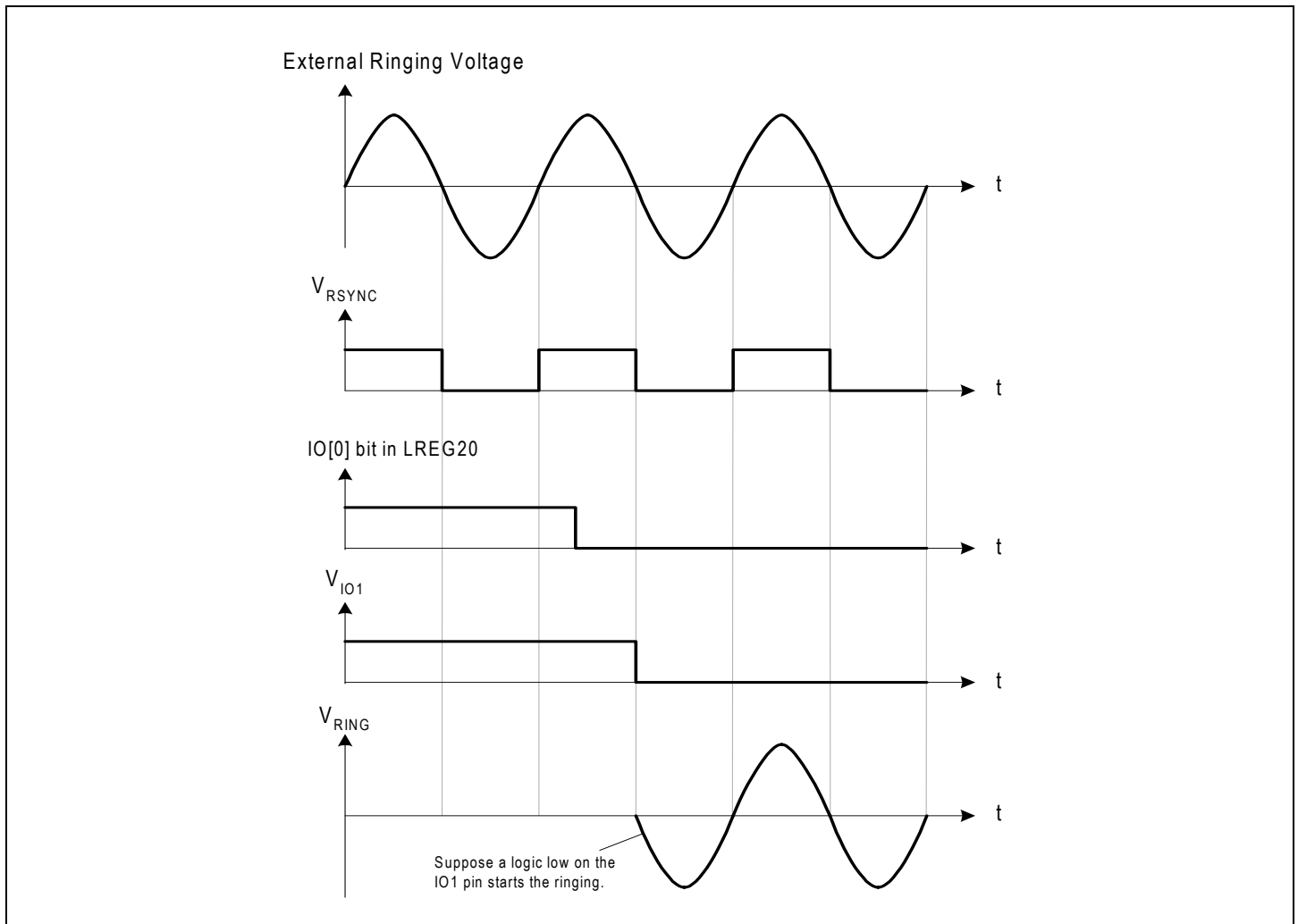

Figure - 12 External Ringing Synchronization

3.4.2.1 Ring Trip Detection In External Ringing Mode

In external ringing mode, the sensed ring current signal is processed by an operational amplifier in the RSLIC and supplied to the CODEC via the RTIN pin for ring trip detection. In external ringing mode, the level meter will be involved when detecting the ring trip. For detailed information about the level meter, please refer to “3.9.4 Level Meter” on page 40.

To detect ring trip, the steps below should be followed:

1. Select the RTIN as the input source to the DC path (LREG9: LM_SEL[3:0] = 1100);
2. Write the external ring trip threshold to HKthld in the Coe-RAM;
3. Set the CODEC to ACTIVE mode and set the RSLIC to External Ringing mode (the chipset operating mode control bits are different in MPI interface and GCI interface, refer to Table - 3 for details);
4. The CODEC processes the RTIN signal and compares the result with the external ring trip threshold written in HKthld in the Coe-RAM. If the threshold is exceeded, the corresponding HK[n] bit in GREG26 (n = 0 to 3 corresponds to Channel 1 to 4) will be set to

1, indicating that off-hook is detected.

When detecting a ring trip, an offset voltage (about 10 to 30 mV) may be introduced by the operational amplifier mentioned above. This offset can be measured by the DC level meter and compensated by writing the corresponding compensation value to DC Offset in the Coe-RAM.

Before measuring this offset voltage, make sure that no external ringing signal is applied to the Tip/Ring lines. The measuring procedure is as follows (to understand the following descriptions, users should understand the level meter first):

1. Set the CODEC to ACTIVE mode and set the RSLIC to External Ringing mode (see Table - 3 for details);
2. Select the RTIN as the input to the DC path of the CODEC (LREG9: LM_SEL[3:0] = 1100);
3. In LREG8, set DC_SRC = 1 and LM_SRC = 0;
4. Select the channel to be measured by setting the LM_CS[1:0] bits in GREG16 accordingly;
5. Set the integrating time to 001H (GREG15 & GREG16: LM_CN[10:0] = 001H);
6. Set the shift factor (K[3:0] in LREG9);

7. Disable the rectifier (LREG10: LM_RECT = 0);
 8. Set the gain factor as required (LREG10: LM_GF);
 9. Set the level meter measurement mode to ONCE and start the measurement (GREG16: LM_ONCE = 1, LM_EN = 1);
 10. Read the measurement result from GREG17 & GREG18 (16-bit);
 11. Right shift the 16-bit result for two bits, then the result is the offset value in the form of a 14-bit two's complement;
 12. Invert each bit of the offset value and add 1 to it, write this result to DC Offset in the Coe-RAM.
 13. Select this offset compensation value to be used (LREG4: DC_OFT = 0);
 14. Restore the modified registers with original contents;
- Then, the four steps mentioned above follow and off-hook event will be more reliably detected.
- [Table - 3](#) shows the registers and Coe-RAM locations used for external ringing mode.

Table - 3 Registers and Coe-RAM Locations Used for External Ringing Mode

Parameter	Register Bits	Notes
CODEC and RSLIC Operating Mode Configuration	MPI mode: bits ACTIVE, SCAN_EN and SM[2:0] in LREG6; GCI mode: bit ACTIVE in LREG6, bits SCAN_EN and SM[2:0] in downstream C/I channel byte.	ACTIVE = 1: the CODEC is set to Active mode SCAN_EN = 1 and SM[2:0] = 001: the RLSIC is set to External Ringing mode.
External Ring Relay Control (recommended)	Bit IO_C[0] in LREG20 Bit IO[0] in LREG20	IO_C[0] = 1: the IO1 pin is configured as an output IO[0] = 0: the IO1 pin is set to logic low IO[0] = 1: the IO1 pin is set to logic high
Synchronous Mode Enable Bit	Bit SYNC_EN in LREG19	SYNC_EN = 0: asynchronous mode is selected SYNC_EN = 1: synchronous mode is selected
External Ring Trip Detection Source	Bit LM_SEL[3:0] in LREG9	LM_SEL[3:0] = 1100: RTIN is selected to the DC path for ring trip detection
External Ring Trip Threshold	Word HKthld in the Coe-RAM	If the Signaling bit in LREG5 is set to 1, the external ring trip threshold in the ROM is selected, otherwise the threshold written in HKthld in the Coe-RAM is selected. The HKthld in the Coe-RAM is programmable from 0 to 20 mA with $\pm 5\%$ tolerance. The default value (in the ROM) is 7 mA. Note that both the off-hook detection threshold in active mode and the external ring trip threshold are written in HKthld in the Coe-RAM. Users should change the threshold according to different conditions.
External Ring Trip Detection Result Indication	Bits HK[n] in GREG26	Indicating the ring trip detection result, '0' means Channel n+1 is on-hook while '1' means Channel n+1 is off-hook (n = 0 to 3).
Level Meter Configuration and Result Registers	LREG8: LM_SRC, DC_SRC LREG9: K[3:0] LREG10: LM_GF, LM_RECT GREG15 & GREG16 GREG17 & GREG18	Refer to Table - 17 on page 44 for details.
DC Offset Compensation	Bit DC_OFT in LREG4 Word DC Offset in the Coe-RAM	DC_OFT = 0: compensation value in word DC Offset in the Coe-RAM is selected; DC_OFT = 1: compensation value (which is 0) in the ROM is selected (default).

3.5 SUPERVISION

Supervision is performed internally by the RSLIC-CODEC chipset. The RSLIC senses the longitudinal and transversal line currents on the Ring and Tip lines, and feeds the corresponding voltages to the CODEC via the VL, VTAC and VTDC pins for further process. In this way, the signaling in the subscriber loop is monitored.

Table - 4 Off-hook Detection in Different Modes

Chipset Mode	CODEC Mode	RSLIC Mode	Mode Control Register Setting
Active	Active	Active	MPI mode: LREG6: ACTIVE = 1, SCAN_EN = 1, SM[2:0] = 000 GCI mode: LREG6: ACTIVE = 1; downstream C/I channel byte: SCAN_EN = 1, SM[2:0] = 000
Sleep	Standby	Standby	MPI mode: LREG6: STANDBY = 1, SCAN_EN = 1, SM[2:0] = 110 GCI mode: LREG6: STANDBY = 1; downstream C/I channel byte: SCAN_EN = 1, SM[2:0] = 110

Note: The operating mode of the CODEC is set by register LREG6. The operating mode of the RSLIC is set by register LREG6 (for MPI mode) or downstream C/I channel byte. Refer to "6.1 Operating Modes" on page 87 for further details.

- Active mode

In this mode, both the RSLIC and the CODEC are active. The RSLIC senses the transversal current on the Ring and Tip lines, and feeds the corresponding voltage to the CODEC via VTDC pin. Inside the CODEC, this voltage is A-to-D converted and filtered. The result is compared with the programmed off-hook threshold (word HKthld in the Coe-RAM). If the result exceeds the threshold, the bit HK[n] (n = 0, 1, 2 or 3) in register GREG26 will be set to 1, indicating that Channel n+1 is off-hook.

3.5.1 OFF-HOOK DETECTION

Loop start signaling is the most common type of signaling. The subscriber loop is closed by the hook switch inside the subscriber equipment. For the RSLIC-CODEC chipset, the off-hook detection can be operated in two different modes as shown in Table - 4.

An interrupt will be generated at the same time if the off-hook mask bit HK_M in register LREG18 is disabled ('0').

In active mode, to detect the loop transition from off-hook to on-hook, the on-hook threshold should be used. The off-hook threshold minus a programmable hysteresis value is the on-hook threshold (as shown in Figure - 13). The hysteresis value is programmed by HKHyst in the Coe-RAM. The default value is 2 mA.

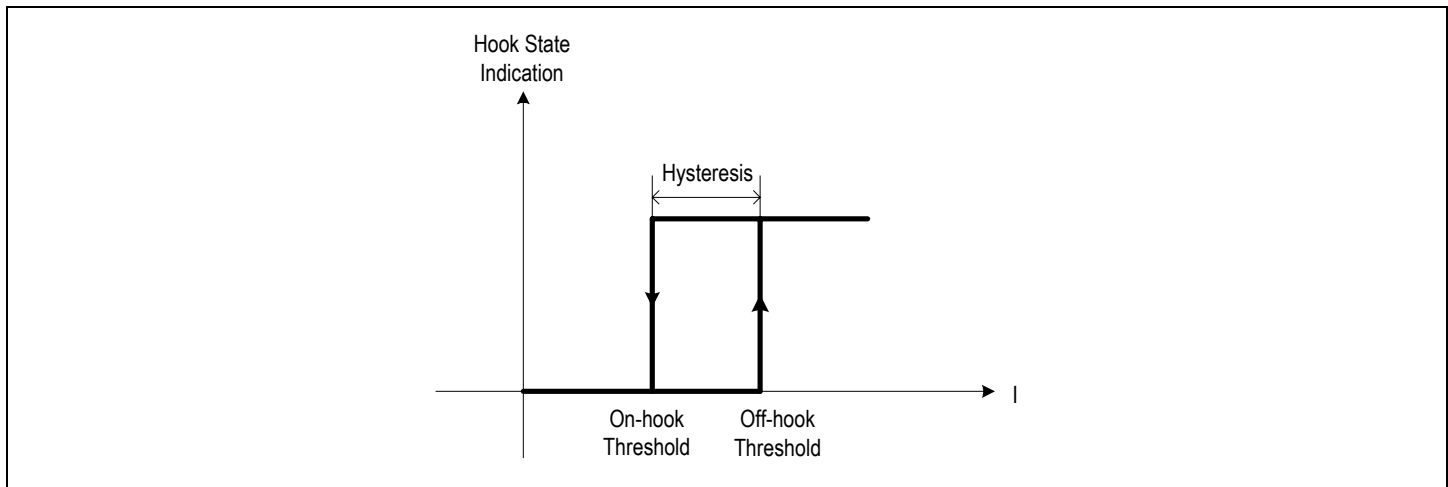

Figure - 13 Hysteresis for Off-Hook Detection

- Sleep mode

In this mode, both the CODEC and the RSLIC are in standby mode. All of the function blocks except off-hook detection stop working. The transversal current on the Ring and Tip lines is sensed by a simple sense circuit and the corresponding sensed voltage is fed to an analog comparator in the CODEC via the VTAC pin. By comparing this sensed voltage with a fixed off-hook threshold of 2 mA, the off-hook event can be detected. Once the loop goes off-hook, the whole chipset should be set to active mode by the master processor.

The CODEC integrates a programmable debounce filter in the off-hook detection circuit to eliminate disturbance. The transversal DC signal (which is taken as the off-hook criterion) will be filtered by this debounce filter. The DC signal with duration less than the debounce time

will be ignored. As shown in Figure - 14, a four-bit debounce counter allows the debounce interval programmable from 0.125 ms to 2 ms. A 16-state up/down counter follows, resulting in the minimal debounce time ranging from 2 ms to 32 ms. The debounce interval is programmed by the DB[3:0] bits in LREG11.

(Note: When the RSLIC operating mode is switching from other mode to the active mode, there might be a narrow pulse of about 15 ms occurring on VTDC, resulting in a false off-hook interrupt to be generated. If this happens, please set the debounce time for off-hook detection to 15 ms or above (i.e., DB[3:0] ≥ 0111B) to filter the noise pulse.)

Table - 5 shows the registers and Coe-RAM locations used for off-hook detection.

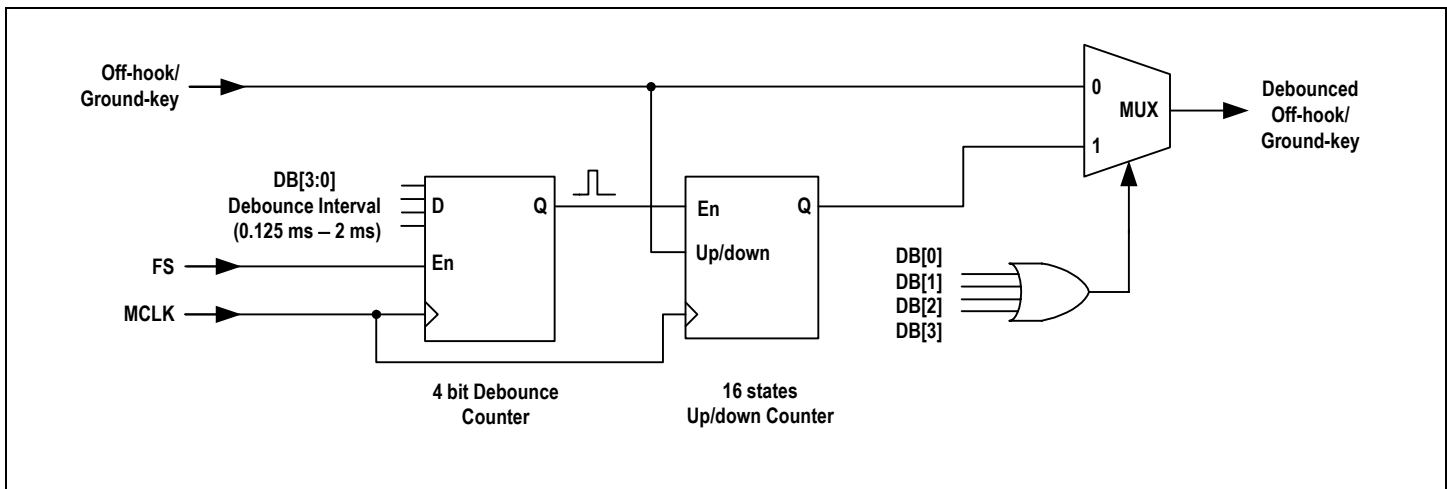

Figure - 14 Debounce Filter for Off-hook/Ground-key Detection

Table - 5 Registers and Coe-RAM Locations Used for Off-hook Detection

Parameter	Register Bits/Coe-RAM Words	Notes
Off-hook Indication	Bits HK[3:0] in GREG26	HK[n] = 0: Channel n+1 is on-hook (n = 0 to 3); HK[n] = 1: Channel n+1 is off-hook.
Mask bit for HK[3:0] bits	Bit HK_M in LREG18	HK_M = 0: each change of HK[3:0] bits generates an interrupt; HK_M = 1: changes of HK[3:0] bits do not generate interrupts.
Off-hook Threshold Selection	Bit Signaling in LREG5	Signaling = 0: the off-hook threshold in the Coe-RAM is selected. Signaling = 1: the off-hook threshold in the ROM is selected (default).
Off-hook Threshold for Active Mode	Word HKthld in the Coe-RAM	If the Signaling bit in LREG5 is set to 0, the off-hook threshold for active mode is programmed by word HKthld in the Coe-RAM. It is programmable from 0 to 20 mA with $\pm 5\%$ tolerance. If the Signaling bit in LREG5 is set to 1, the default value of 7 mA (stored in the ROM) is selected.
Hysteresis for Off-hook Detection	Word HKHyst in the Coe-RAM	If the Signaling bit in LREG5 is set to 0, the hysteresis for off-hook detection is programmed by word HKHyst in the Coe-RAM. It is programmable from 0 to 20 mA with $\pm 5\%$ tolerance. If the Signaling bit in LREG5 is set to 1, the default value of 2 mA (stored in the ROM) is selected.
Debounce Interval Selection	Bits DB[3:0] in LREG11	The interval is programmable from 0.125 ms to 2 ms in steps of 0.125 ms. The default value of DB[3:0] is '0000', corresponding to the minimum debounce interval of 0.125 ms.

3.5.2 GROUND-KEY DETECTION

In applications of using ground-key signaling, the longitudinal current of the loop is used as ground-key criterion. The RSLIC senses the longitudinal current and transfers the scaled longitudinal voltage information to the CODEC via VL pin. An analog comparator for ground-key detection compares this voltage with a fixed threshold (11.8 mA). If the threshold is exceeded, the bit GK[n] (n = 0, 1, 2 or 3) in register GREG26 will be set to 1 to indicate that ground-key is detected in Channel n+1. An interrupt will occur if any bit of GK[3:0] changing from 0 to 1. The GK[3:0] bits can be masked by the GK_M bit in register LREG18.

The polarity of the longitudinal current is indicated by the GK_POL bit in register LREG21. Each change of the GK_POL bit generates an interrupt. The GK_POL bit can be masked by the GKP_M bit in register LREG18.

An application example is shown in the following:

- Tip open or Ring open mode

In this case, the Tip line or the Ring line is switched to high impedance, the longitudinal current on the Ring or Tip line is sensed by the RSLIC and fed to the CODEC through the VL pin for testing.

The longitudinal DC signal (which is taken as the ground-key criterion) is also filtered by the programmable debounce filter used in off-hook detection. The DC signal with duration less than the denounce time will be ignored. The debounce interval is programmable by the DB[3:0] bits in register LREG11. Refer to [Figure - 14](#) for details.

[Table - 6](#) shows the registers used for ground-key detection.

Table - 6 Registers Used for Ground-key Detection

Parameter	Register Bits	Notes
Ground-key Indication	Bits GK[3:0] in GREG26	GK[n] = 0: no longitudinal current detected in Channel n+1 (n = 0 to 3); GK[n] = 1: longitudinal current detected in Channel n+1.
Mask bit for GK[3:0] bits	Bit GK_M in LREG18	GK_M = 0: each change of the GK[3:0] bits generates an interrupt; GK_M = 1: changes of the GK[3:0] bit do not generate interrupts.
Ground-key Polarity	Bit GK_P in LREG21	GK_P = 0: negative ground-key threshold level active; GK_P = 1: positive ground-key threshold level active.
Mask bit for GK_P bit	Bit GKP_M in LREG18	GKP_M = 0: each change of the GK_P bit generates an interrupt; GKP_M = 1: changes of the GK_P bit do not generate interrupt.
Debounce Interval Selection	Bits DB[3:0] in LREG11	The interval is programmable from 0.125 ms to 2 ms in steps of 0.125 ms.

3.6 METERING BY POLARITY REVERSAL

The RSLIC-CODEC supports metering by reversing the polarity of the voltage on the Tip and Ring lines. The actual polarity of this voltage is reversed by setting the REV_POL bit in register LREG19 to 1.

The voltage polarity is reversed in a smooth way to avoid generating non-required ringing. Users can control the transition time (time from start to end of polarity reversal) by programming the built-in ramp generator. Refer to "[Ramp Generator](#)" on [page 47](#) for further details.

3.7 ENHANCED SIGNAL PROCESSING

Besides the fundamental BORSCHT functions, the RSLIC-CODEC chipset also provides several additional functions such as Tone Generation, FSK generation for Caller-ID and Universal Tone Detection. These additional functions can be individually enabled or disabled according to the requirements of applications.

3.7.1 TONE GENERATOR

The CODEC provides two tone generators for each channel: Tone Generator 1 (TG1) and Tone Generator 2 (TG2). They can be used to generate signals such as a test tone, DTMF, dial tone, busy tone, congestion tone and Caller-ID alerting tone etc., and output them to the RSLIC via the ACP and ACN pins.

The TG1 and TG2 of each channel can be enabled by setting bits TG1_EN and TG2_EN in register LREG7 to 1, respectively.

If the TG bit in register LREG4 is set to 1, the default frequency and amplitude values in the ROM are selected for tone generators (default: TG1Amp = 0.94 V, TG1Freq = 852 Hz, TG2Amp = 0.94 V, TG2Freq = 1447 Hz). Otherwise, the frequency and amplitude values of TG1 and TG2 are programmed by the Coe-RAM. The frequency and amplitude

coefficients can be calculated, respectively, by the following formulas:

$$f < 2000 \text{ Hz, Frequency coefficient} = 8191 * \cos(f/8000 * 2 * \pi)$$

$$f > 2000 \text{ Hz, Frequency coefficient} = 16384 - 8191 * \cos(f/8000 * 2 * \pi)$$

$$\text{Amplitude coefficient} = A * 8191 * \sin(f/8000 * 2 * \pi)$$

Herein, 'f' is the desired frequency of the tone. 'A' is the scaling parameter for the tone amplitude. The range of 'A' is from 0 to 1.

$$A = 1, \text{ corresponding to the maximum amplitude, } 1.57 \text{ (V);}$$

$$A = 0, \text{ corresponding to minimum amplitude, } 0 \text{ (V).}$$

It is a linear relationship between 'A' and the amplitude, which means if $A = \beta$ ($0 < \beta < 1$), the amplitude will be $1.57 * \beta$ (V).

The frequency is programmable from 25 Hz to 3400 Hz. The tolerance is as follows:

$$f < 200 \text{ Hz, tolerance} < \pm 3\%;$$

$$f > 200 \text{ Hz, tolerance} < \pm 1.5\%.$$

The amplitude and frequency coefficients of the tone signal can be calculated by the Cal74 software automatically. Refer to [Table - 7](#) for more information about registers and Coe-RAM used for tone generators.

Note that when using the dual tone generators, users must write 2000H (high byte: 20H; low byte: 00H) to block2 word4 of the Coe-RAM to ensure proper operation.

Table - 7 Registers and Coe-RAM Locations Used for Tone Generation

Parameter	Register Bits/Coe-RAM Words	Notes
TG Frequency and Amplitude Coefficients Selection	Bit TG in LREG4	TG = 0: The frequency and amplitude coefficients in the Coe-RAM are selected for the tone generators; TG = 1: The frequency and amplitude coefficients in the ROM are selected for the tone generators (default);
TG1 Enable/Disable Bit	Bit TG1_EN in LREG7	TG1_EN = 0: TG1 is disabled. TG1_EN = 1: TG1 is enabled.
TG1 Amplitude Coefficient	Word TG1Amp in the Coe-RAM	The amplitude is programmable from 0 V to 1.57 V with $\pm 1\%$ tolerance. The default amplitude (in the ROM) is 0.94 V.
TG1 Frequency Coefficient	Word TG1Freq in the Coe-RAM	The frequency is programmable from 25 to 3400 Hz. The tolerance is $\pm 3\%$ ($f < 200$ Hz) or $\pm 1.5\%$ ($f > 200$ Hz). The default frequency (in the ROM) is 852 Hz.
TG2 Enable/Disable Bit	Bit TG2_EN in LREG7	TG2_EN = 0: TG2 is disabled TG2_EN = 1: TG2 is enabled
TG2 Amplitude Coefficient	Word TG2Amp in the Coe-RAM	The amplitude is programmable from 0 V to 1.57 V with $\pm 1\%$ tolerance. The default amplitude (in the ROM) is 0.94 V.
TG2 Frequency Coefficient	Word TG2Freq in the Coe-RAM	The frequency is programmable from 25 to 3400 Hz. The tolerance is $\pm 3\%$ ($f < 200$ Hz) or $\pm 1.5\%$ ($f > 200$ Hz). The default frequency (in the ROM) is 1447 Hz.

3.7.1.1 DTMF Generation

Dual Tone Multi-Frequency (DTMF) is a signaling scheme using voice frequency tones to signal dialing information. A DTMF signal is the sum of two tones, one from the low frequency group (697 - 941 Hz) and one from the high frequency group (1209 - 1633 Hz), with each group containing four individual tones. This scheme allows 16 unique combinations. Ten of these codes represent the numbers from zero through nine on the telephone keypad, the rest six codes (*, #, A, B, C, D) are reserved for special signaling. The buttons are arranged in a matrix, with the rows determining the low group tones, and the columns determining the high group tone for each button.

Based on the scheme described in the preceding paragraph, a DTMF signal can be generated by the two tone generators. By

programming the amplitude and frequency of the tone generators through MPI or GCI interface, the 16 standard DTMF pairs can be generated independently in each channel. The generated DTMF tone signals meet the frequency variation tolerances specified in the ITU-T Q.23 recommendation.

3.7.2 FSK GENERATION FOR CALLER ID

The RSLIC-CODEC chipset provides an optimized FSK generator for sending Caller ID information. Different countries use different standards to send Caller ID information by FSK codes. The FSK modulation of the RSLIC-CODEC chipset is compatible with the most common standards: BELL 202 and ITU-T V.23. [Table - 8](#) shows the modulation characteristics of these two standards.

Table - 8 FSK Modulation Characteristics

Characteristic	ITU-T V.23	BELL 202
Mark (Logic 1)	1300 ± 3 Hz	1200 ± 3 Hz
Space (Logic 0)	2100 ± 3 Hz	2200 ± 3 Hz
Modulation	FSK	
Transmission Rate	1200 ± 6 baud	
Data Format	Serial binary asynchronous	

Generally, the transmission of the FSK signal starts with a Seizure Signal, which is a string of '01' pairs. Then a Mark Signal which is a string of '1' follows. The Caller ID information comes after the Mark Signal. Between two bytes of the Caller ID information, a Flag Signal

which is a string of '1' is inserted so that the receiver can have enough time to process the received bytes. The transmission sequence of the FSK signal is shown in [Figure - 15](#).

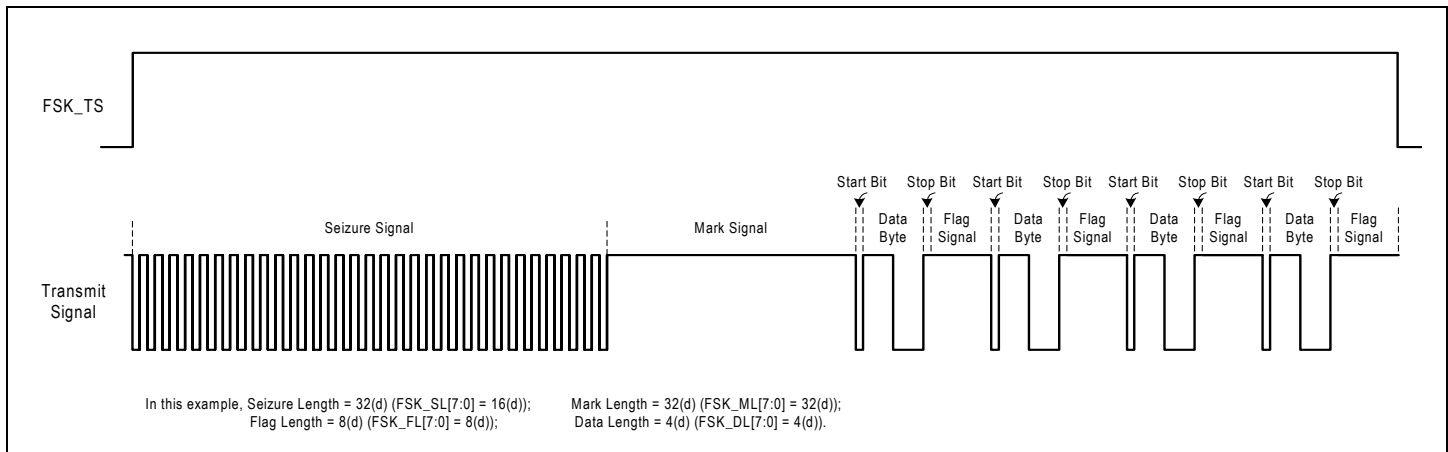

Figure - 15 FSK Signal Transmission Sequence

The lengths of the Seizure Signal, Mark Signal, Flag Signal and Caller ID data are programmable by register GREG21, GREG22, GREG19 and GREG20, respectively.

The CODEC provides total 64 bytes RAM (called FSK-RAM) to store the Caller ID information. If the length of the information is less than 64 bytes, all information bytes can be written to the FSK-RAM at one time. If the length of the information is longer than 64 bytes, the information should be divided into two or more segments according to its actual length (each segment ≤ 64 bytes). Write one segment to the FSK-RAM at one time. When this segment has been sent out, the FSK-RAM can be updated with the next segment. Repeat the same operation until all segments have been sent out. Refer to [“5.2.4 Addressing the FSK-RAM” on page 60](#) for further details on accessing the FSK-RAM via MPI or GCI interface.

The FSK generator is controlled by register GREG23, as described in the following:

- Bit FSK_EN. This bit is used to enable or disable the FSK generator. The FSK_EN bit must be set to 1 to enable the FSK generator before FSK transmission starts. When the transmission is finished, the FSK_EN bit should be set to 0 to disable the FSK generator.

- Bits FSK_CS[1:0]. These two bits are used to select a channel to send FSK signal (the FSK generator is shared by four channels).

- Bit FSK_BS. This bit is used to select one of the two FSK modulation standards BELL 202 and ITU-T V.23.

- Bit FSK_TS. This bit is used to start the FSK transmission. Once the FSK_TS bit is set to 1, the FSK generator begins to send the data

written in the FSK-RAM automatically, following the procedure shown below:

- Step 1: Start, send Seizure Signal;
- Step 2: Send Mark Signal;
- Step 3: Send one start bit (0), one byte of data in the FSK-RAM, one stop bit (1), then send Flag Signal;
- Step 4: Check whether all data in the FSK-RAM has been sent out. If it has, set the FSK_TS bit to 0 and stop, otherwise return to step 3.

- Bit FSK_MAS. This bit determines whether the FSK generator will output a mark-after-send signal (a string of '1') after the data in the FSK-RAM has been sent out. If total Caller ID information is longer than 64 bytes, the FSK_MAS bit should be set to 1. After sending out one segment, the FSK generator will keep sending out a mark-after-send signal to hold the established communication channel for sending the remaining segment(s). After all segments have been sent out, the FSK_MAS bit should be set to 0 so that the output of the FSK generator will be muted. Once the FSK_MAS bit is 0, changing it from 0 to 1 will not make the mark-after-send signal active until a new transmission starts (FSK_TS = 1).

If total Caller ID information is less than 64 bytes, the FSK_MAS bit should be set to 0 so that the output will be muted after all information has been sent out.

Note that the Caller ID information is read from or written to the FSK-RAM via MPI or GCI interface with MSB first; but the FSK codes are sent out by the FSK generator through the selected channel with LSB first.

Table - 9 shows the configuration and control registers used for the FSK generator. Refer to Figure - 16 on page 33 for a recommended programming flow chart for FSK generation.

Table - 9 Registers and FSK-RAM Used for the FSK Generator

Parameter	Register Bits/FSK-RAM	Notes
Flag Length	Bits FSK_FL[7:0] (GREG19)	The length of the Flag Signal is programmable from 0 to 255 (bits).
Data Length	Bits FSK_DL[7:0] (GREG20)	Data Length is the number of the Caller ID data bytes written in the FSK-RAM. The valid data length is 0 to 64 (bytes).
Seizure Length	Bits FSK_SL[7:0] (GREG21)	Seizure Length is the number of '01' pairs that represent the seizure signal. The length of the Seizure Signal is two times of the value specified in GREG21. That means, Seizure Length can be up to 510 pairs.
Mark Length	Bits FSK_ML[7:0] (GREG22)	The length of the Mark Signal is programmable from 0 to 255 (bits).
Transmit Start	Bit FSK_TS in GREG23	FSK_TS = 1: FSK transmit start. The FSK_TS bit will be cleared to 0 automatically after the data in the FSK-RAM is completely sent out.
Mark After Send	Bit FSK_MAS in GREG23	After the data in the FSK-RAM is sent out, if FSK_MAS = 1, the FSK generator sends out a mark-after-send signal (a string of '1'), otherwise, the output of the FSK generator is muted.
FSK Modulation Standard Selection	Bit FSK_BS in GREG23	FSK_BS = 0: BELL 202 is selected; FSK_BS = 1: ITU-T V.23 is selected.
FSK Generator Enable	Bit FSK_EN in GREG23	FSK_EN = 0: FSK generator is disabled; FSK_EN = 1: FSK generator is enabled.
FSK Channel Selection	Bits FSK_CS[1:0] in GREG23	Select one of the four channels to send the Caller ID data.
FSK Data RAM	FSK-RAM	Total 64 bytes

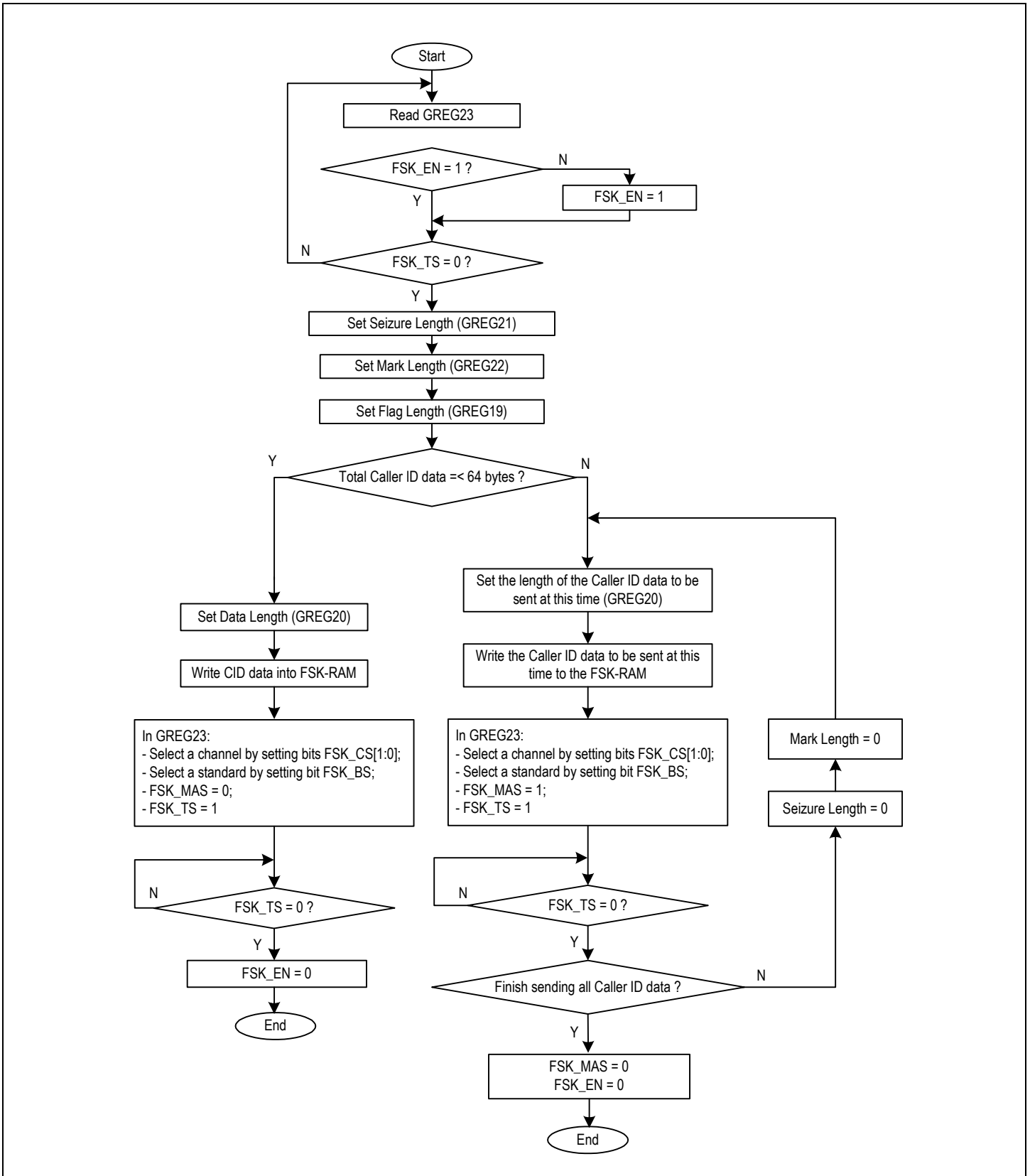

Figure - 16 Recommended Programming Flow Chart for FSK Generation

3.7.3 UNIVERSAL TONE DETECTION (UTD)

3.7.3.1 Introduction

The RSLIC-CODEC chipset provides optimized solution not only for voice transmission, but for modem data transmission. The performance of the latter is becoming a key performance for the increasing internet access and other data applications. The chipset's universal tone (fax/modem tone) detection allows the use of modem-optimized filter for V.34 and V.90 connections.

The CODEC provides an integrated Universal Tone Detection (UTD) unit per channel to detect fax and modem tones from the transmit or receive path. The UTD unit can detect tone signals whose frequencies are between 1500 Hz and 2600 Hz.

If a fax or modem tone is detected, which means that a modem connection is about to be established, the lowpass filter (see [Figure - 9 on page 20](#)) characteristic is changed to a modem-optimized one. If the modem data transmission is completed, the lowpass filter characteristic will be switched back to the voice-optimized one for voice data

transmission. With this mechanism implemented in the chipset, the optimum modem transmission rate can always be achieved.

The characteristic of the lowpass filter can be changed by software. If the V90 bit in register LREG5 is set to 1, this filter will be configured for V90 connections (modem-optimized), otherwise it will be configured for V34 connections (voice-optimized).

3.7.3.2 UTD Principle

As shown in [Figure - 17](#) (UTD Functional Block Diagram), the input signal from transmit or receive path is first filtered by a programmable bandpass filter and a programmable bandstop filter separately. The in-band (upper path) and out-of-band (lower path) signals are then separated from each other and the corresponding absolute values are calculated. The two calculated results are sent to two integrators, respectively. Finally, the evaluation logic block determines whether a tone is detected by comparing the in-band level with the out-of-band level.

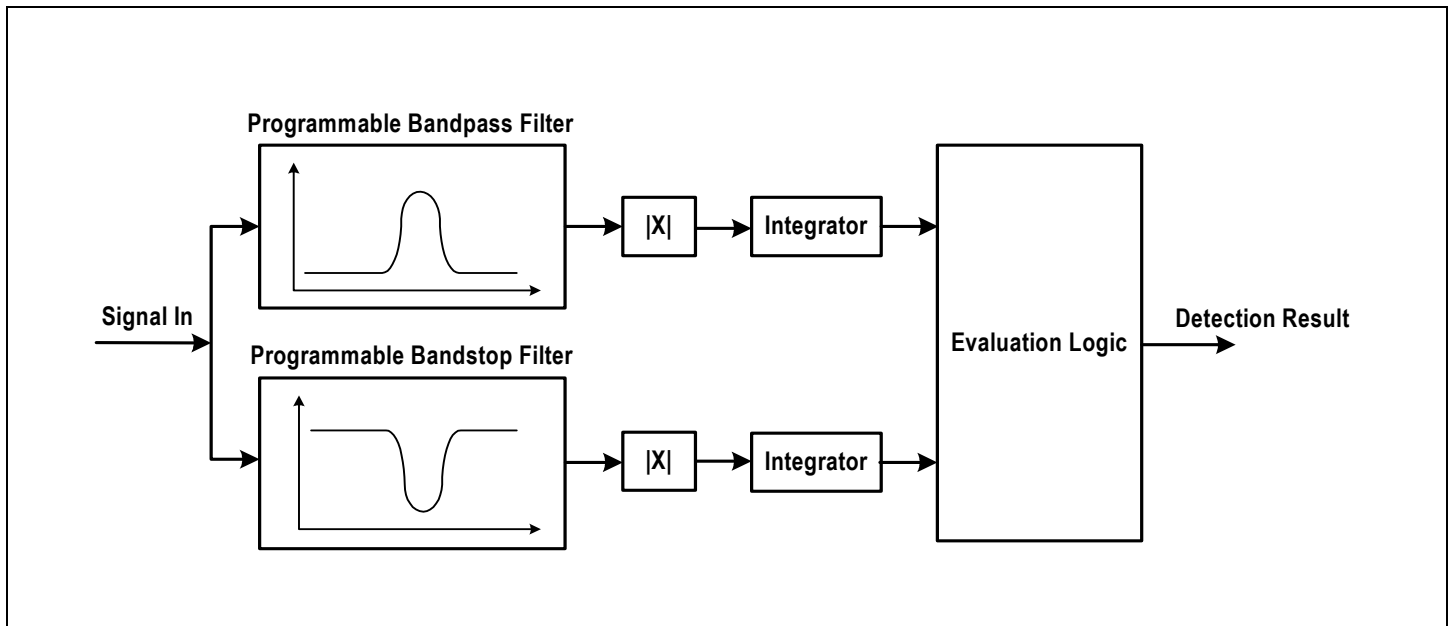

Figure - 17 UTD Functional Diagram

If a tone has been detected in the receive or transmit path, the UTD_OK bit in LREG21 will be set to 1 and an interrupt will be generated.

The UTD_OK bit will be set to 1 if all the following conditions hold for a time span of at least a Recognition Time (RTime, programmable by LREG14) without occurring breaks longer than a Recognition Break Time (RBRKTime, programmable by LREG15):

- The in-band signal level is higher than out-band signal level.
- The in-band signal level is higher than the floor threshold (programmable by word UTDthld_Floor in the Coe-RAM).

- The in-band signal level is lower than the ceiling threshold (programmable by word UTDthld_Ceiling in the Coe-RAM).

[Figure - 18](#) shows an example of UTD recognition timing.

The UTD_OK bit will be reset to 0 if one of the preceding conditions is violated for at least a time span of an End Detection Time (ETime, programmable by LREG16) during which the violation does not cease for at least an End Detection Break Time (EBRKTime, programmable by LREG17). Refer to [Figure - 19](#) for an example of UTD tone end detection timing.

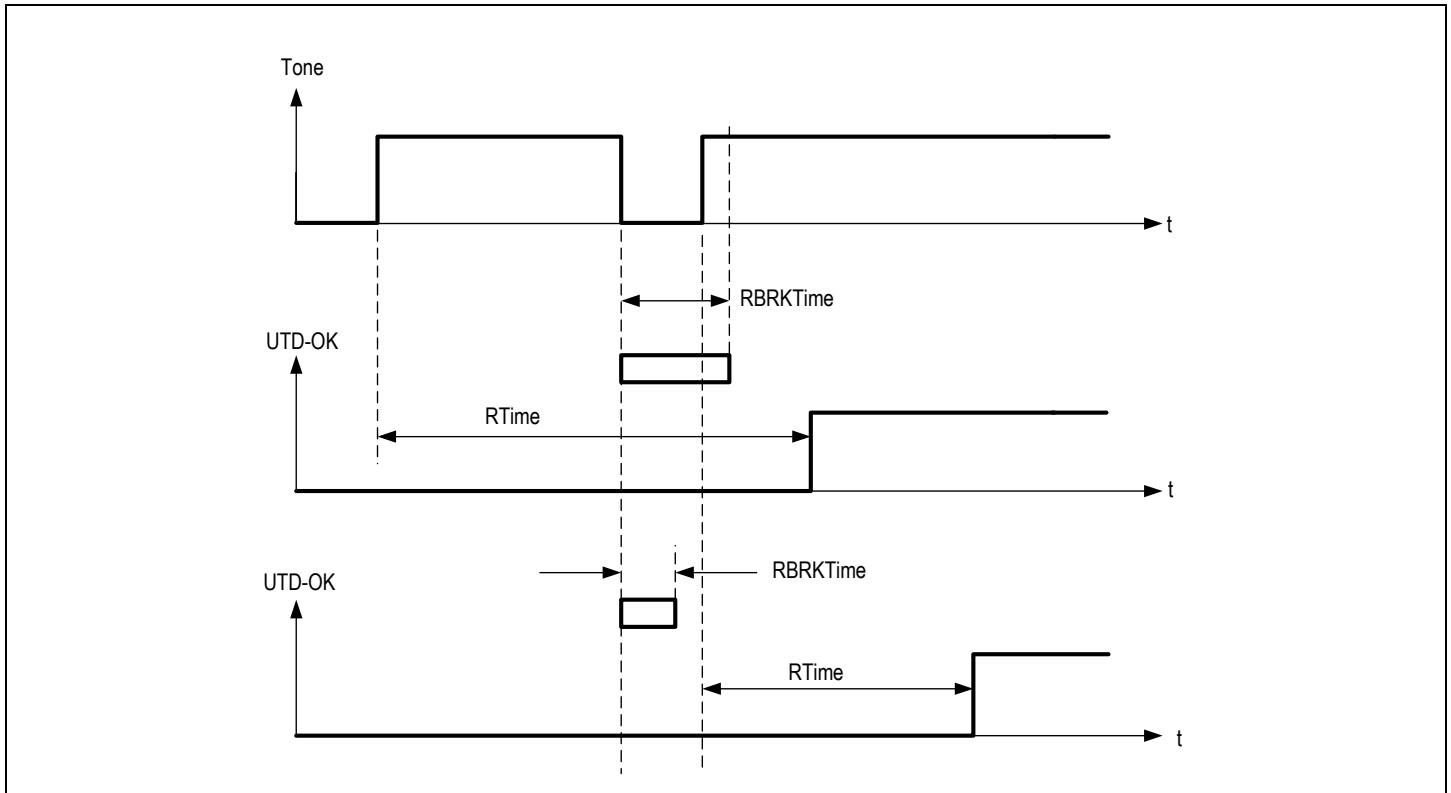

Figure - 18 Example of UTD Recognition Timing

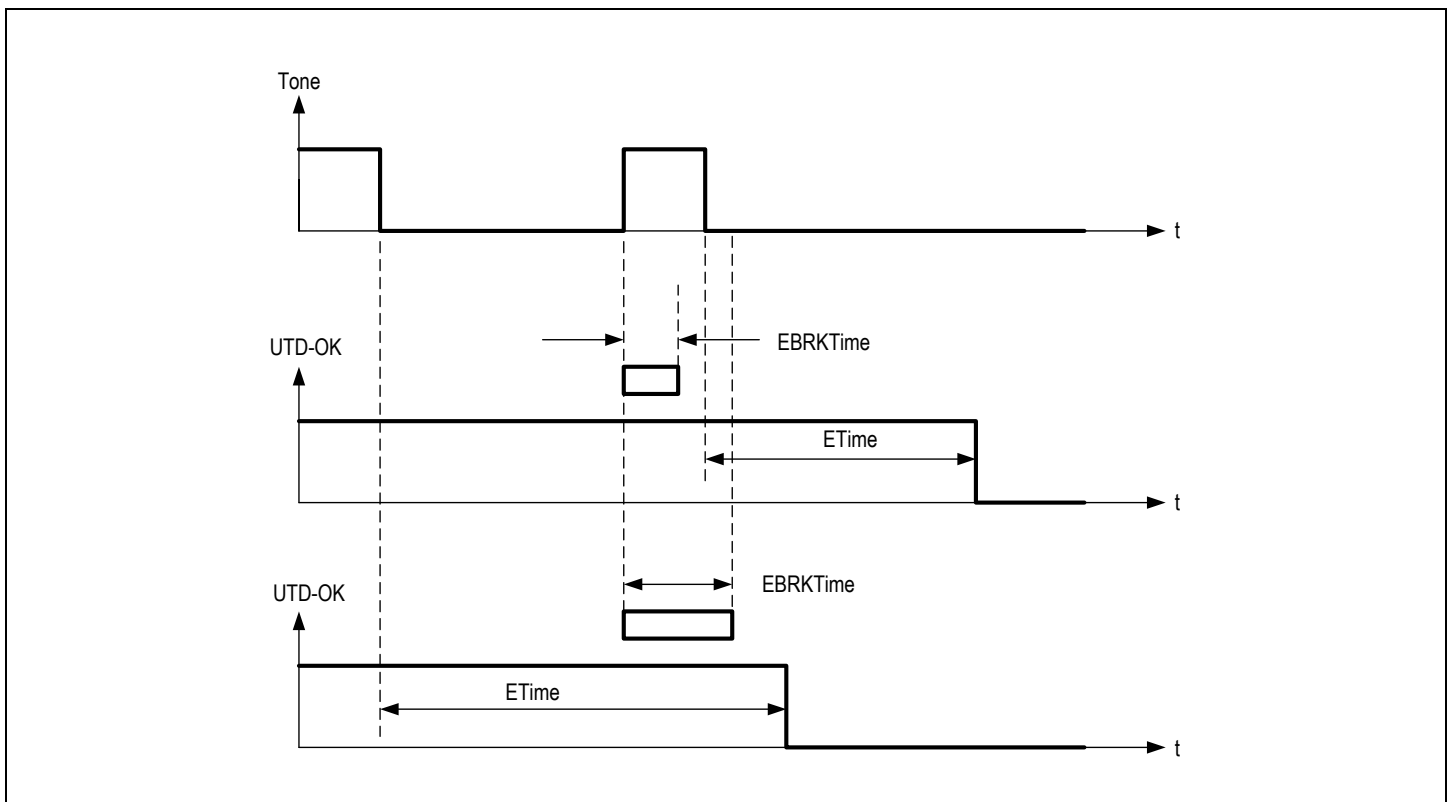

Figure - 19 Example of UTD Tone End Detection Timing

3.7.3.3 UTD Programming

Table - 10 shows the registers and Coe-RAM locations used for the UTD unit.

The UTD unit can be enabled or disabled individually for each channel by the UTD_EN in register LREG8. The UTD_SRC bit in LREG8 determines whether the signal from transmit or receive path is detected. The RTime, RBRKTime, ETime and EBRKTime of the UTD are programmed by LREG14, LREG15, LREG16 and LREG17, respectively.

If the UTD bit in LREG5 is set to 0, the coefficients of the bandpass and the bandstop filters and the thresholds of the signal are programmable via the Coe-RAM. The center frequencies of the two filters should be the same. The center frequency can be programmed

from 1500 Hz to 2600 Hz. The bandwidths of the two filters are also programmable. The ceiling and floor thresholds of the signal can be programmed from -30 dBm to 0 dBm in minimum steps of 0.2 dBm.

IDT provides a software (Cal74) to calculate the filter and threshold coefficients. When users input the desired center frequency, bandwidth for the two filters and ceiling threshold, floor threshold for the signal, the software will automatically calculate all the coefficients for the UTD unit. After loading these coefficients to the Coe-RAM, the performance of the UTD unit will meet the users' requirements. Refer to Table - 23 on page 62 for the Coe-RAM mapping.

If the UTD bit is set to 1, the filter coefficients and the thresholds in the ROM are used. These values are used by default. See Table - 10 for details.

Table - 10 Registers and Coe-RAM Locations Used for UTD

Parameter	Register Bits/Coe-RAM Words	Notes
UTD Unit Enable	Bit UTD_EN in LREG8	UTD_EN = 0: the UTD unit is disabled; UTD_EN = 1: the UTD unit is enabled.
UTD Source Selection	Bit UTD_SRC in LREG8	UTD_SRC = 0: signal from receive path is detected; UTD_SRC = 1: signal from transmit path is detected.
UTD Result Indication	Bit UTD_OK in LREG21	UTD_OK = 0: no fax/modem tone has been detected; UTD_OK = 1: fax/modem tone has been detected.
UTD RTime	Bits UTD_RT[7:0] (LREG14)	Recognition time, programmable from 0 to 4000 ms. The default value is 304 ms.
UTD RBRKTime	Bits UTD_RBK[7:0] (LREG15)	Recognition break time, programmable from 0 to 1000 ms. The default value is 100 ms.
UTD ETime	Bits UTD_ET[7:0] (LREG16)	End detection time, programmable from 0 to 1000 ms. The default value is 256 ms.
UTD EBRKTime	Bits UTD_EBRK[7:0] (LREG17)	End detection break time, programmable from 0 to 255 ms. The default value is 100 ms.
UTD Filter Coefficients and Signal Thresholds Selection	Bit UTD in LREG5	UTD = 0: The signal thresholds and filter coefficients written in the Coe-RAM are selected. UTD = 1: The signal thresholds and filter coefficients in the ROM are selected (default);
UTD Bandpass Filter Coefficient	UTD Bandpass Filter Coefficient in the Coe-RAM	The center frequency is programmable from 1500 Hz to 2600 Hz. The default center frequency and bandwidth (in the ROM) are 2100 Hz and 60 Hz respectively.
UTD Bandstop Filter Coefficient	UTD Bandstop Filter Coefficient in the Coe-RAM	The center frequency is programmable from 1500 Hz to 2600 Hz. The default center frequency and bandwidth (in the ROM) are 2100 Hz and 230 Hz respectively.
UTD Signal Ceiling Threshold	UTDthld_Ceiling in the Coe-RAM	Programmable from -30 dBm to 0 dBm in minimum steps of 0.2 dBm. The default value (in the ROM) is -6 dBm.
UTD Signal Floor Threshold	UTDthld_Floor in the Coe-RAM	Programmable from -30 dBm to 0 dBm in minimum steps of 0.2 dBm. The default value (in the ROM) is -18 dBm.

3.8 THREE-PARTY CONFERENCE

3.8.1 INTRODUCTION

The RSLIC-CODEC chipset provides a three-party conference facility on the PCM interface in MPI mode only. With this facility, either an external three-party conference or an internal three-party conference can be held without additional hardware.

Figure - 20 shows the conference block diagram. When an external conference mode is selected (GREG7: CONF_X_EN=1), the chipset acts

as a server for three external calling partners (B, C and D) to hold a conference with each other. When an internal conference mode is selected (GREG7: CONF_EN=1), a conference can be held between an internal calling partner (S) and two external calling partners (B and C). The internal calling partner is a subscriber connected to one of the four channels of the local CODEC. The external calling partners do not need any conference facility, for the chipset performs all the functions required by a conference for them.

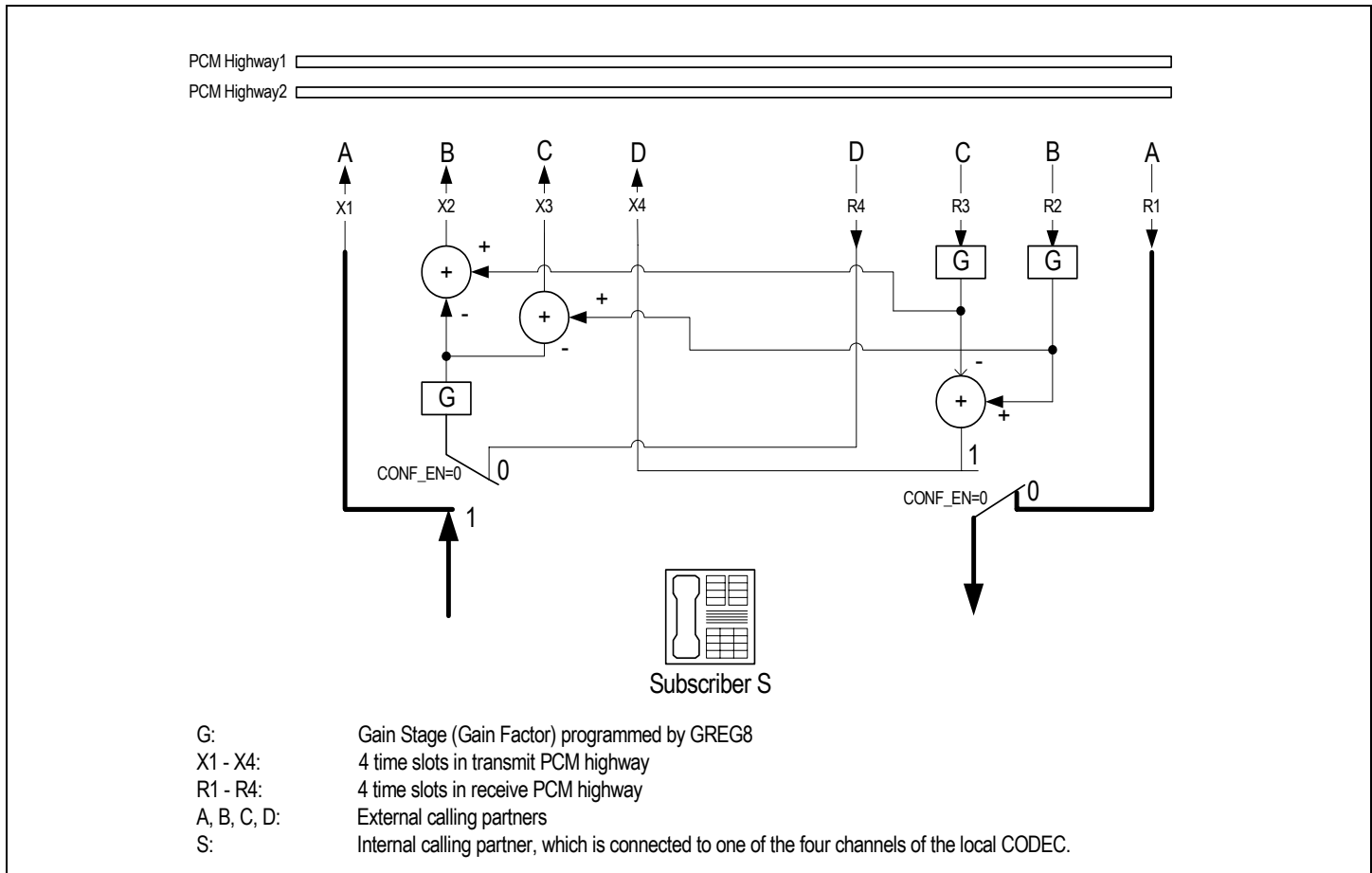

Figure - 20 Conference Block Diagram

The three-party conference facility consists of adders, gain stages, PCM configuration registers and a conference control register. The voice data in the receive time slots of any two partners is added by the adder and sent to the transmit time slot of the third partner. The registers GREG9, GREG11 and GREG13 are used to select transmit PCM highway and time slot for the three partners. The registers GREG10, GREG12 and GREG14 are used to select receive PCM highway and time slot for the three partners. To avoid overflow of the sum signals, a programmable gain stage (G) is used. The gain is programmed by GREG8. The CONF_EN and CONF_X_EN bits in GREG7 are used to select the internal and external conferences respectively. If internal conference is selected, the CONF_CS[1:0] bits in GREG7 are used to select one of the four channels of the local CODEC to attend the conference.

Both A/ μ -law compressed (8-bit) and linear (16-bit 2's complement)

voice data can be transferred in a three-party conference. If compressed data format is selected, at least 7 time slots are needed in the transmit/receive PCM highway to perform a three-party conference and use the four local channels at the same time (three time slots for partners B, C and D, four time slots for local Channel 1 to 4). So the lowest BCLK frequency should be 512 kHz, corresponding to 8 time slots available.

3.8.2 PCM INTERFACE CONFIGURATION

The PCM interface can be configured to work in different mode as shown in Table - 11. The P_DOWN bit in LREG6 is used to power down the specify channel of the CODEC. When all four channels of the chipset are powered down, no data is transferred via the PCM highways. The P_DOWN bit together with the CONF_EN and CONF_X_EN bits control the conference behavior and the PCM line drivers.

Table - 11 Conference Mode

Mode	Configuration Bits			Receive Time Slots				Transmit Time Slots				Subscriber S
	P_DOWN (LREG6)	CONF_EN (GREG7)	CONFX_EN (GREG7)	R1	R2	R3	R4	X1	X2	X3	X4	
PCM Off	1	0	0	-	-	-	-	Off	Off	Off	Off	Off
PCM Active	0	0	0	A	-	-	-	S	Off	Off	Off	A
External Conference	1	0	1	-	B	C	D	Off	G(C+D)	G(B+D)	G(B+C)	Off
External Conference + PCM Active	0	0	1	A	B	C	D	S	G(C+D)	G(B+D)	G(B+C)	A
Internal Conference	0	1	0	-	B	C	-	Off	G(C+S)	G(B+S)	Off	G(B+C)

- PCM Off

When the chipset is just reset, or in the power down state, no data is transferred via the PCM highways. Also when selecting new time slots, it's recommended to switch off the PCM line drivers by setting the corresponding P_DOWN bit to 1, CONF_EN bit and CONFX_EN bit to 0.

- PCM Active

This is the normal operating mode without conference. Only time slots R1 and X1 are used. Voice data is transferred from an external subscriber A to an internal subscriber S.

- External Conference

In this mode the chipset acts as a conferencing server for subscribers B, C and D. These three partners may be controlled by any device connected to the PCM highways. To reduce the power consumption, the channels of the local CODEC can be powered down if they are not being used.

- External Conference + PCM Active

As in the external conference mode, any external three-party conference is supported in this mode. At the same time, if the channels of the local CODEC are powered on (active), the subscribers connected to the corresponding channels can make normal phones calls.

- Internal Conference

If the subscriber S is one of the conference partners, the internal conference mode should be selected. Then, A three-party conference can be held between the internal partner S and the external partners B and C. In this mode, the CODEC channel which the partner S is connected must be powered on.

3.8.3 CONTROL THE ACTIVE PCM CHANNELS

Table - 12 shows the register configuration for the transmit PCM channels. For details refer to "4.1.2 PCM Interface" on page 51.

Table - 12 Active PCM Channel Configuration Bits

Control Bits				Transmit PCM Time Slot			
P_DOWN (LREG6)	CONF_EN (GREG7)	CONFX_EN (GREG7)	L_CODE (GREG3)	X1	X2	X3	X4
1	0	0	-	-	-	-	-
0	0	0	0	PCM	-	-	-
0	0	0	1	HB LB	-	-	-
0	1	0	0	-	PCM	PCM	-
0	1	0	1	-	HB LB	HB LB	-
0	1	0	0	PCM	PCM	PCM	-
0	1	0	1	HB LB	HB LB	HB LB	-
1	0	1	0	-	PCM	PCM	PCM
1	0	1	1	-	HB LB	HB LB	HB LB
0	0	1	0	PCM	PCM	PCM	PCM
0	0	1	1	HB LB	HB LB	HB LB	HB LB
1	1	1	0	-	PCM	PCM	PCM
1	1	1	1	-	HB LB	HB LB	HB LB
0	1	1	0	PCM	PCM	PCM	PCM
0	1	1	1	HB LB	HB LB	HB LB	HB LB

NOTES:

In [Table - 11](#) and [Table - 12](#):

1. The 'P_DOWN' bit (in register LREG6) is used to power down the corresponding channel of the CODEC: P_DOWN = 1, power down; P_DOWN = 0, power on.
2. The 'L_CODE' bit (in register GREG3) is used to select the PCM data format: L_CODE = 1, linear code; L_CODE = 0, A/ μ -law compressed code.
3. 'PCM' means PCM compressed data (A-law/ μ -law).
4. HB and LB represent the high byte and low byte of the linear data respectively.
5. Modes in rows with gray background are for testing purpose only.

3.9 ITDF

3.9.1 INTRODUCTION

Subscriber lines are often affected by many types of failures, e.g., short circuits, broken lines, leakage currents, noise etc. Service providers must be able to perform line tests and respond quickly if there are any failures.

Traditional line cards solutions usually need external relays and test equipment to accomplish line tests. The RSLIC-CODEC chipset provides integrated test and diagnosis functions (ITDF) that can monitor and diagnose line faults and line card device failures without test relays or test equipment. With the ITDF implemented, the chipset increases the test possibilities, reduces the testing time and cost and provides more flexibility for system manufacturers and service providers over traditional solutions.

3.9.2 DIAGNOSIS AND TEST FUNCTIONS

A set of signal generators and features are implemented in the chipset to accomplish various diagnosis functions. The CODEC generates an appropriate test signal, applies it to the loop, measures the resulting voltage or current signal level and reports the result to a master microprocessor. All the tests can be initiated by the microprocessor and results can be read back very easily. By monitoring the subscriber loop, the ITDF might prevent any problems caused by the subscriber line or line equipment from affecting the service.

The chipset can accomplish the following test and measurement functions:

- Loop resistance
- Leakage current Tip/Ring
- Leakage current Tip/GND
- Leakage current Ring/GND
- Ringer capacitance
- Line capacitance
- Line capacitance Tip/GND
- Line capacitance Ring/GND
- External voltage measurement Tip/GND
- External voltage measurement Ring/GND
- External voltage measurement Tip/Ring
- Measurement of ringing voltage
- Measurement of line feed current
- Measurement of supply voltage VDD of the CODEC
- Measurement of transversal and longitudinal currents

3.9.3 INTEGRATED SIGNAL GENERATORS

The signal generators available on the chipset are as follows:

- Constant DC voltage generation (programmable ringing DC offset voltages);
- Two independent tone generators (TG1 and TG2) per channel (used to generate DTMF signal and various test tones. Please refer to "3.7.1 Tone Generator" on page 30 for details);
- Ramp generator (used for capacitance measurement, refer to page 47 for details);
- Ring generator (used to generate an internal balanced ringing signal. Refer to "3.4.1.1 Internal Ringing Generation" on page 23 for details).

3.9.4 LEVEL METER

An on-chip level meter together with the signal generators mentioned accomplishes all test and diagnosis functions. Figure - 21 on the following page shows the entire level meter block diagram.

3.9.4.1 Level Meter Source Selection

The level meter is shared by all four channels. The LM_CS[1:0] bits in register GREG16 select one of the channels for level metering. For each channel, there are one AC signal source and ten DC signal sources to be selected. The LM_SRC and DC_SRC bits in register LREG8 and the LM_SEL[3:0] bits in register LREG9 make the selection. See Table - 13 for details.

Table - 13 Level Meter Source Selection

LM_SRC	DC_SRC	LM_SEL[3:0]	Level Meter Source
1	x	xxxx	AC signal in transmit path (VTAC)
0	0	xxxx	Digital DC signal
0	1	0000	DC voltage on VTDC (default)
0	1	0100	DC output voltage on DCN-DCP
0	1	1001	DC voltage on VL
0	1	1010	Voltage on IO3
0	1	1011	Voltage on IO4
0	1	1100	Voltage on RTIN
0	1	1101	VDD/2
0	1	1110	Offset voltage (VCM is selected)
0	1	1111	Voltage on IO4-IO3

Attention: The VTDC is selected as the level meter source by default. When the CODEC works in active mode, it automatically adjusts the DC feeding according to the DC voltage on the VTDC pin. So, selecting inputs VL, IO3, IO4, IO3-IO4, DCN-DCP or VDD/2 as the level meter source may disturb the DC feeding regulation and cause problems in the DC loop. To avoid this, users can freeze the output of the DC loop before selecting these inputs as the sources by setting the ACTIVE bit in LREG6 to 0.

• AC Level Meter

If the LM_SRC bit in register LREG8 is set to 1, the AC signal in the transmit path (VTAC) is selected for level metering.

The AC level meter can measure the voice signal at 8 kHz while the active voice signal is being processed (see Figure - 21). After being pre-filtered, A/D converted and decimated, the signal can be filtered by a programmable filter. The LM_FILT bit in LREG8 determines whether the filter is enabled. If the filter is enabled, the LM_NOTCH bit in LREG8 determines which filter characteristic (notch or bandpass) is selected.

LM_FILT = 0: the filter is disabled (normal operation);

LM_FILT = 1: the filter is enabled;

LM_NOTCH = 0: notch filter characteristic is selected;

LM_NOTCH = 1: bandpass filter characteristic is selected.

The filter coefficients can be from the Coe-RAM or from the ROM, as selected by the LM_N and LM_B bits in LREG5.

LM_N = 0: the coefficient in the Coe-RAM is used for the notch filter;

LM_N = 1: the coefficient in the ROM is used for the notch filter;
 LM_B = 0: the coefficient in the Coe-RAM is used for the bandpass filter;
 LM_B = 1: the coefficient in the ROM is used for the bandpass filter;
 The center frequency of the notch/bandpass filter is programmable

from 300 Hz to 3400 Hz. The default center frequency is 1014 Hz. The quality factor (Q) is fixed to 5. The filter coefficients are automatically calculated by a software (Cal74) provided by IDT. When users input the center frequency, this software will calculate the coefficient for the notch or bandpass filter. By loading the coefficients to the Coe-RAM of the CODEC, the filter characteristic can meet the requirements. Refer to [Table - 23 on page 62](#) for the Coe-RAM mapping.

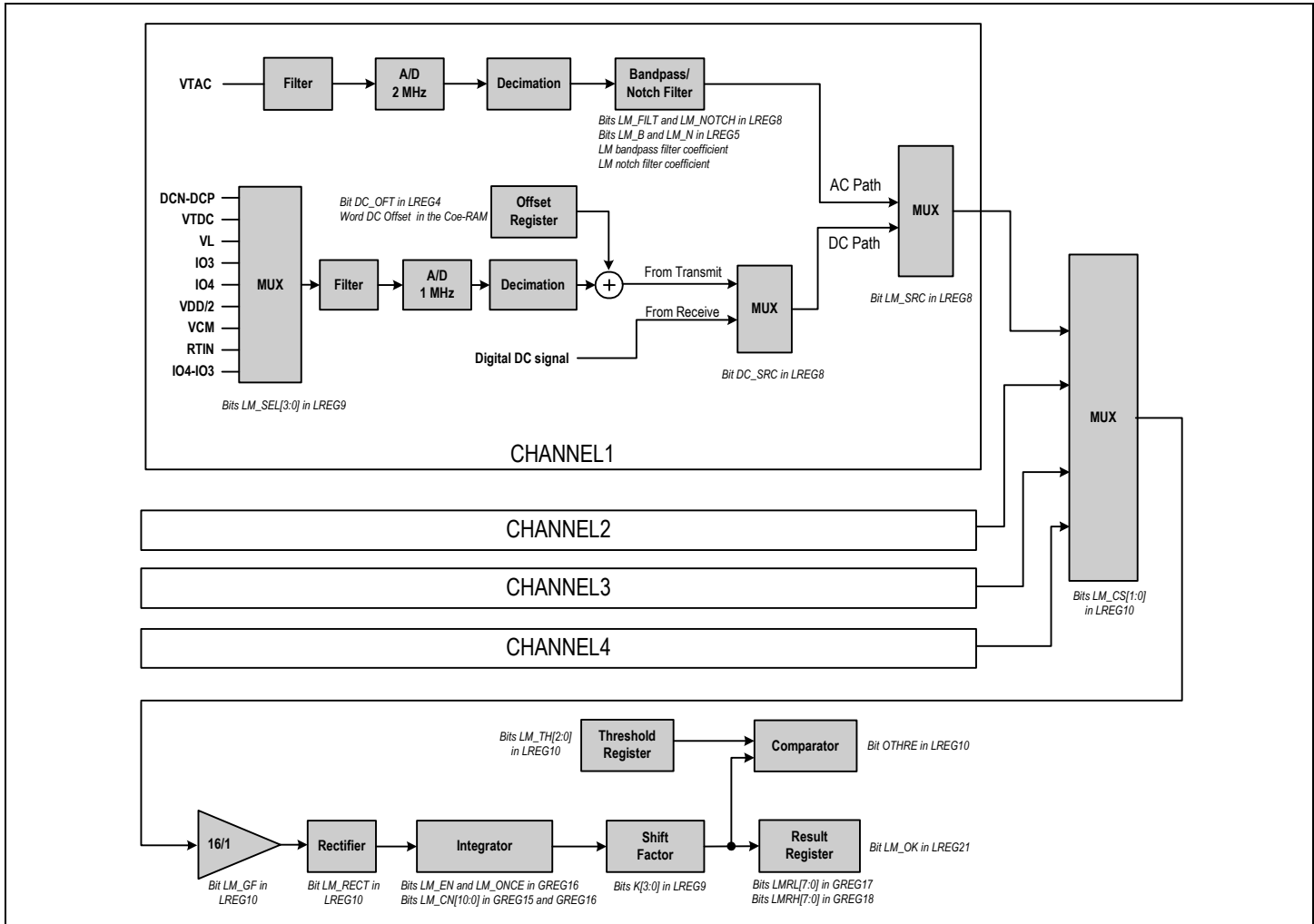

Figure - 21 Level Meter Block Diagram

• DC Level Meter

If the LM_SRC bit in register LREG8 is set to 0, the DC level meter is selected to perform the measurement. The DC signal source can be from transmit or receive path depending on the DC_SRC bit in register LREG8:

DC_SRC = 0: DC signal (digital) from receive path is selected;
 DC_SRC = 1: DC signal from transmit path is selected.

There are a total of nine DC signal sources in the transmit path. They are specified by the LM_SEL[3:0] bits in register LREG9. Refer to [Table - 13](#) for details.

As [Figure - 21](#) shows, the selected signal from DC transmit path is filtered, A/D converted and decimated. The effective sampling rate after the decimation stage is 8 kHz. The Offset Register here is used to compensate for the current and voltage offset errors. See “[3.9.6.1 Offset Current Measurement](#)” on [page 45](#) and “[3.9.6.7 Voltage Offset](#)

Measurement” on [page 49](#) for details.

3.9.4.2 Level Meter Gain Filter and Rectifier

The selected signal from the AC or DC path is further processed by a programmable digital gain filter. The additional gain factor is either 1 or 16 depending on the LM_GF bit in register LREG10:

LM_GF = 0: No additional gain factor;
 LM_GF = 1: Additional gain factor of 16.

The LM_GF bit should be set to 0 unless the tested signal is small enough.

A rectifier follows to change the minus signal to plus signal. It can be enabled or disabled by the LM_RECT bit in register LREG10:

LM_RECT = 1: rectifier enabled;
 LM_RECT = 0: rectifier disabled.

3.9.4.3 Level Meter Integrator

An integrator is used to accumulate and sum up the signal values over a preset period. The accumulation period (count number) is programmable from 0 to 255.875 ms in steps of 0.125 ms, by the bits LM_CN[10:0] in registers GREG15 and GREG16. The integrator can be configured to run once or continuously by the LM_ONCE bit in GREG16:

LM_ONCE = 0: integrator runs continuously;

LM_ONCE = 1: integrator runs once.

In continuous mode, the integrator starts to accumulate the samples

after the LM_EN bit in register GREG16 is set to 1. When the count number is reached, which means that once integration is finished, the LM_OK bit in LREG21 will be set to 1 and an interrupt will be generated. The next integration starts right after the previous integration is finished, and the LM_OK bit will be automatically reset after 125 μ s. The integrator runs continuously in this way and will not stop unless the LM_EN bit is set to 0. Figure - 22 shows the continuous measurement sequence.

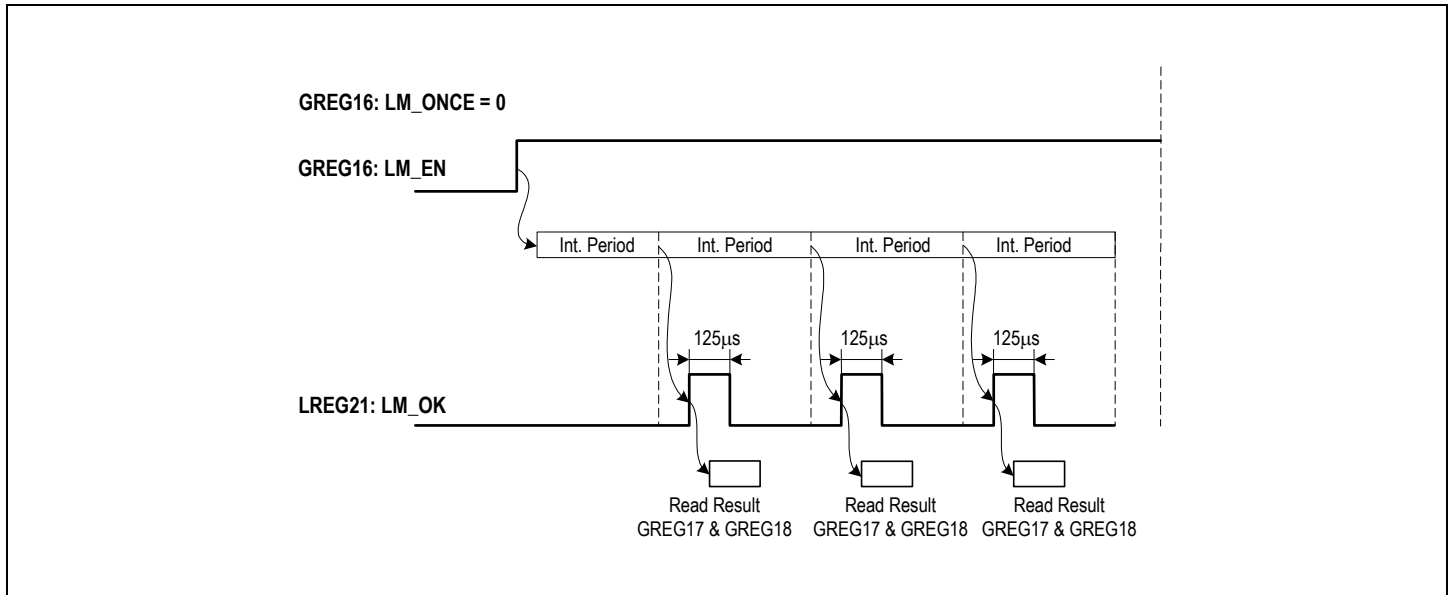

Figure - 22 Continuous Measurement Sequence (AC & DC Level Meter)

In single mode, the integrator works only once after each initiation (LM_EN = 1). Once the integration is finished, the LM_OK bit will be set to 1 and will not be reset until the LM_EN bit is set to 0. To start a new

integration, the LM_EN bit must be changed from 0 to 1. The single measurement sequence is illustrated in Figure - 23.

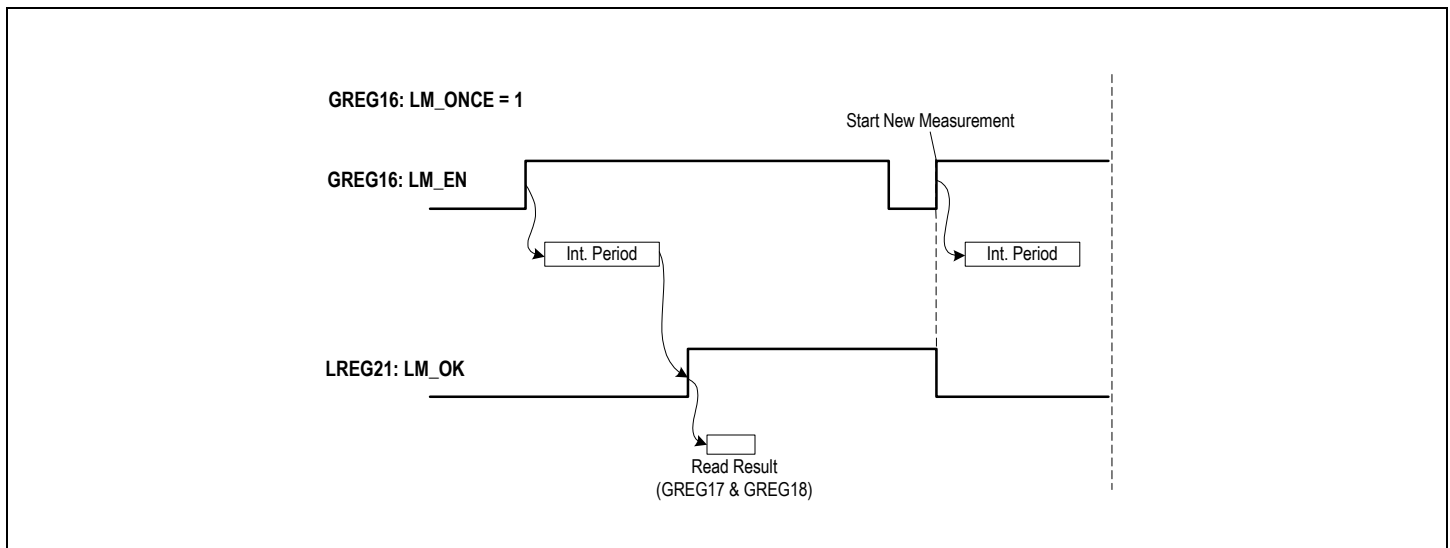

Figure - 23 Single Measurement Sequence (AC & DC Level Meter)

In both continuous and single modes, the level meter result LM_{Value} is sent to registers GREG17 & GREG18 after every integration period. To calculate the measured signal level, a factor LM_{Result} is defined as:

$$LM_{Result} = \frac{LM_{Value}}{32768}$$

The number of samples $N_{Samples}$ for the integrator is calculated by:

$$N_{Samples} = LM_CN$$

Where, LM_CN is the level meter count number (set by bits LM_CN[10:0] in registers GREG15 & GREG16).

Then the signal level can be calculated by the following formula:

$$Udbm0 = 20 \times \log\left(LM_{Result} \times \frac{\pi}{2 \times K_{INT} \times N_{Samples}}\right) + 3.14$$

Where, K_{INT} is the selected shift factor. Refer to “3.9.4.5 Level Meter Shift Factor” for details.

3.9.4.4 Level Meter Result Register

The level meter result is a 16-bit 2's complement. The low byte and high byte of it are stored in registers GREG17 and GREG18 respectively. Table - 14 shows the range of the result value.

Table - 14 Level Meter Result Value Range

Negative Value Range		Positive Value Range	
- Full scale			+ Full scale
0x8000	0xFFFF	0	0x7FFF
- 32768	- 1	0	+ 32768

3.9.4.5 Level Meter Shift Factor

As the level meter result is a 16-bit 2's complement while the integration width is 27 bits, a shift factor is necessary to avoid generating an overflow in result registers and make the results with maximum accuracy. The shift factor K_{INT} is programmed by register LREG9. See Table - 15 for details.

Table - 15 Shift Factor Selection

K[3:0] bits in LREG9	Shift Factor
0000	$K_{INT} = 1$
0001	$K_{INT} = 1/2$
0010	$K_{INT} = 1/4$
0011	$K_{INT} = 1/8$
0100	$K_{INT} = 1/16$
0101	$K_{INT} = 1/32$
0110	$K_{INT} = 1/64$
0111	$K_{INT} = 1/128$
1000	$K_{INT} = 1/256$
1001	$K_{INT} = 1/512$
1010	$K_{INT} = 1/1024$
1011 to 1111	$K_{INT} = 1/2048$

3.9.4.6 Level Meter Threshold Setting

Once the level meter result is latched in the result registers, it will be compared with a programmable threshold. If the absolute value of the result exceeds the threshold, the OTHRE bit in register LREG10 will be set to 1.

This threshold is a percentage value of the full scale (see Table - 14). It is programmed by the LM_TH[2:0] bits in LREG10. Refer to Table - 16 for details.

Table - 16 Level Meter Threshold Setting

LM_TH[2:0] in LREG10			Threshold
LM_TH[2]	LM_TH[1]	LM_TH[0]	
0	0	0	0%
0	0	1	12.5%
0	1	0	25.0%
0	1	1	37.5%
1	0	0	50.0%
1	0	1	62.5%
1	1	0	75.0%
1	1	1	87.5%

Table - 17 sums up the registers and Coe-RAM locations used for the level meter.

Table - 17 Registers and Coe-RAM Locations Used for the Level Meter

Parameter	Register Bits/Coe-RAM Words	Notes
Level meter channel selection	LM_CS[1:0] bits in GREG16	The LM_CS[1:0] bits determine the signal from which channel to be level metered.
Level meter source selection	LM_SRC and DC_SRC bits in LREG8 LM_SEL[3:0] bits in LREG9	Refer to Table - 13 for details.
Level meter shift factor selection	K[3:0] bits in LREG9	Refer to Table - 15 for details.
Level meter count number (integration time) selection	LM_CN[10:0] bits in GREG15 & GREG16	The LM_CN[10:0] bits is programmable from 0 to 7FFH, corresponding to the integration time of 0.125 ms to 255.875 ms.
Level meter result	LMRL[7:0] bits in GREG17 (low byte) LMRH[7:0] bits in GREG18 (high byte)	See Table - 14 for details.
Level meter threshold	Threshold selection: LM_TH[2:0] bits in LREG10 Over threshold indication: OTHRE bit in LREG10	Refer to Table - 16 for details on threshold selection. Once the selected threshold is exceeded, the OTHRE bit will be set to 1.
Level meter bandpass/notch filter configuration	LM_FILT and LM_NOTCH bits in LREG8	LM_FILT = 0: bandpass/notch filter is disabled; LM_FILT = 1: bandpass/notch filter is enabled; LM_NOTCH = 0: notch filter characteristic is selected; LM_NOTCH = 1: bandpass filter characteristic is selected.
Level meter bandpass/notch filter coefficient selection	LM_B and LM_N bits in LREG5	LM_B = 0: The coefficient in the Coe-RAM is selected for the bandpass filter; LM_B = 1: The coefficient in the ROM is selected for the bandpass filter (default); LM_N = 0: The coefficient in the Coe-RAM is selected for the notch filter; LM_N = 1: The coefficient in the ROM is selected for the notch filter (default).
LM Bandpass Filter Coefficient	LM Bandpass Filter Coefficient in the Coe-RAM	When LM_B = 1, this coefficient will be selected for the bandpass filter.
LM Notch Filter Coefficient	LM Notch Filter Coefficient in the Coe-RAM	When LM_N = 1, this coefficient will be selected for the notch filter.
Level meter enable	LM_EN bit in GREG16	A logic high in this bit starts a level meter measurement while a logic low stops the measurement.
Indication of Level meter measurement completed	LM_OK bit in LREG21	Once the measurement is finished, the LM_OK bit will be set to 1.
Level meter gain filter configuration	LM_GF bit in LREG10	This bit selects a gain factor of 1 or 16 for the level meter gain filter.
Level meter rectifier enable	LM_RECT bit in LREG10	This bit is used to enable or disable the level meter rectifier as required.
Level meter integrator work mode	LM_ONCE bit in GREG16	This bit determines whether the integrator works once or continuously.
Offset Register in the level meter	DC_OFT bit in LREG4 word DC Offset in the Coe-RAM	DC_OFT = 0: The compensation value in the Coe-RAM is selected for the Offset Register; DC_OFT = 1: The default compensation value of 0 is selected for the Offset Register.

3.9.5 MEASUREMENT VIA AC LEVEL METER

3.9.5.1 Current Measurement via VTAC

In order to measure current via the VTAC pin, all feedback loops (impedance matching filters and transhybrid balance filter) should be disabled. To simplify the formulas, the programmable receive and transmit gain (GTX, FRX, GRR and FRR) are disabled by corresponding registers (refer to "3.3.2 Programmable Filters" on page 21 for details). Based on this a factor K_{ADAC} (gain of analog to digital in AC loop) can be defined:

$$K_{ADAC} = 1$$

The transversal current I_{RMS} measured at the RSLIC:

$$I_{RMS} = \frac{LM_{Result} \times \pi}{K_{ADAC} \times K_{INT} \times N_{Samples} \times K_{ITAC} \times 2 \times \sqrt{2}}$$

$$LM_{Result}: LM_{Result} = LM_{Value} / 32768$$

$$N_{Samples}: N_{Samples} = LM_{CN}$$

$$K_{INT}: \text{Value of the shift factor}$$

$$K_{ITAC}: \text{Value of the AC current to voltage converter for transversal voltage (} R_{Sense} \text{ is the sense resistance)}$$

$$K_{ITAC} = 8 \times R_{Sense}$$

3.9.5.2 AC Level Meter Operational State Flow

The operational state flow for the AC level meter is as the following:

1. The level meter is in the disable state ($LM_EN = 0$), the result registers (GREG17 & GREG18) are cleared.
2. Set the level meter count number ($LM_CN[10:0]$) in registers GREG15 and GREG16.
3. Enable the level meter ($LM_EN = 1$) and it starts to accumulate the samples. When the preset count number is reached, the LM_OK bit is set and the accumulation result will be latched into the result registers simultaneously. If the result exceeds the preset threshold, the $OTHRE$ bit in LREG10 will be set.
4. If the LM_ONCE bit is 0 (continuous mode), the level meter continues to measure the next samples right after one measurement is finished, the LM_OK bit is reset after 125 μs .
5. If the LM_ONCE bit is 1 (single mode), the level meter runs one time after the it is initiated and the LM_OK bit will not be reset until the LM_EN bit is set to 0.

3.9.6 MEASUREMENT VIA DC LEVEL METER

3.9.6.1 Offset Current Measurement

The current offset error is caused by the current sensor inside the RSLIC. The current offset can be measured by the DC level meter. The following settings are necessary to accomplish this measurement:

- The RSLIC is set to Normal Active mode (for MPI interface, LREG6: $SCAN_EN = 1$, $SM[2:0] = 000$; for GCI interface, downstream C/I channel: $SCAN_EN = 1$, $SM[2:0] = 000$) and the loop is on-hook. In this condition, there should be no current present, but the current sensor incorrectly indicates a current flowing (current offset error).

- Select VTDC and VL to the DC level meter separately (by setting bits $LM_SEL[3:0]$ in LREG9 to '0000' and '1001' respectively).
- The value in the Offset Register must be set to 0 (by clearing the word/DC Offset in the Coefficient RAM).
- Then the transversal and longitudinal offset currents ($I_{Tdc, Off-Err}$ and $I_{Ldc, Off-Err}$) can be calculated.

$$V_{Tdc, Off-Err} = \frac{LM_{Result}}{K_{ADDC} \times K_{INT} \times N_{Samples}}$$

$$V_{Ldc, Off-Err} = \frac{LM_{Result}}{K_{ADDC} \times K_{INT} \times N_{Samples}}$$

$$I_{Tdc, Off-Err} = \frac{V_{Tdc, Off-Err}}{K_{ITDC}}$$

$$I_{Ldc, Off-Err} = \frac{V_{Ldc, Off-Err}}{K_{IL}}$$

K_{ITDC} : Value of the DC current to voltage converter for transversal current (R_{Sense} is the sense resistance)

$$K_{ITDC} = \frac{2}{5} \times R_{Sense}$$

K_{IL} : Value of the current to voltage for longitudinal current

$$K_{IL} = R_{Sense}$$

K_{INT} : Value of the shift factor

K_{ADDC} : Gain of analog to digital conversion in the DC loop

$$K_{ADDC} = \frac{1}{2}$$

3.9.6.2 Leakage Current Measurement

The leakage current Tip/Ring, leakage current Tip/GND and leakage current Ring/GND can be measured by the DC level meter when the RSLIC is in on-hook mode. The following settings are necessary to accomplish the leakage current measurement:

- The RSLIC must be set to Normal Active mode when measuring the leakage current Tip/Ring.
- The RSLIC must be set to Tip Open mode when measuring the leakage current Ring/GND.
- The RSLIC must be set to Ring Open mode when measuring the leakage current Tip/GND.
- Select VTDC to the DC level meter (LREG9: $LM_SEL[3:0] = 0000$);
- $I_{Leakage}$ can be calculated as shown below:

$$I_{Leakage - TipIEND} = \frac{LM_{Result} \times 2}{K_{ADDC} \times K_{INT} \times N_{Samples} \times K_{ITDC}} - \frac{I_{Tdc, Off-Err} - I_{Ldc, Off-Err}}{2}$$

$$I_{Leakage - RingIEND} = \frac{LM_{Result} \times 2}{K_{ADDC} \times K_{INT} \times N_{Samples} \times K_{ITDC}} - \frac{I_{Tdc, Off-Err} + I_{Ldc, Off-Err}}{2}$$

$$I_{Leakage - TipIRing} = \frac{LM_{Result} \times 2}{K_{ADDC} \times K_{INT} \times N_{Samples} \times K_{ITDC}} - I_{Tdc, Off-Err}$$

3.9.6.3 Loop Resistance Measurement

The DC loop resistance can be determined by supplying a constant DC voltage (V_{TRDC}) to the Tip/Ring pair and measuring the DC loop current via the VTDC pin. The following steps are necessary to accomplish the loop resistance measurement:

- Program a certain ring offset voltage (Refer to “3.4.1.1 Internal Ringing Generation” on page 23 for details) and apply it to the Tip/Ring pair;
- Set the RSLIC to Normal Active mode (for MPI interface, LREG6: SCAN_EN = 1, SM[2:0] = 000; for GCI interface, downstream C/I channel: SCAN_EN = 1, SM[2:0] = 000). Set the CODEC to Ring Pause mode (for both MPI and GCI interfaces, LREG6: RING = 1, RING_EN = 0).
- Select VTDC as the level meter source (LM_SRC = 0; DC_SRC = 1; LM_SEL[3:0] = 0000);
- The transversal current (I_{Trans}) can be determined by reading the level meter result registers (GREG17 and GREG18);
- Based on the known constant output voltage V_{TRDC} and the measured I_{Trans} current, the resistance can be calculated. It should be noted that the calculated resistance also includes the on board sense resistors.

$$R_{Loop} = \frac{V_{TRDC}}{I_{Trans}} = V_{TRDC} / \left(\frac{LM_{Result}}{K_{ADDC} \times K_{INT} \times N_{Samples} \times K_{ITDC}} \right)$$

Figure - 24 shows an example circuit for loop resistance measurement.

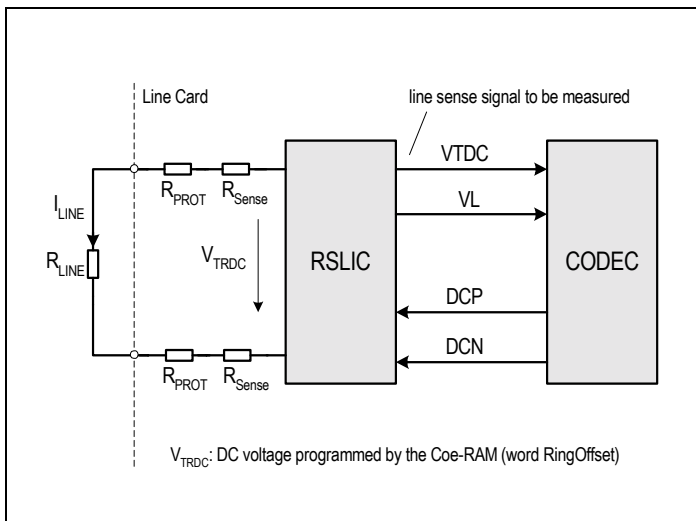

Figure - 24 Example for Resistance Measurement

In order to increase the accuracy of the result, either the current offset can be compensated or the measurement can be done differentially. The latter eliminates both the current and voltage offsets.

To measure the loop resistance R_{Loop} differentially, follow the sequence below:

- Program a certain ring offset voltage and apply it to the Tip/Ring pair via the RSLIC;
- Set the RSLIC to Normal Active mode (for MPI interface, LREG6: SCAN_EN = 1, SM[2:0] = 000; for GCI interface, downstream C/I channel: SCAN_EN = 1, SM[2:0] = 000). Set the CODEC to Ring

Pause mode (for both MPI and GCI interfaces, LREG6: RING = 1, RING_EN = 0).

- Select VTDC as the level meter source (LM_SRC = 0; DC_SRC = 1; LM_SEL[3:0] = 0000);
- Read level meter result registers GREG17 and GREG18.
- Reverse the voltage between Tip and Ring lines by setting the REV_POL bit in LREG19 to 1.
- Read level meter result registers GREG17 and GREG18.

Figure - 25 describes the offset elimination by the differential measurement method.

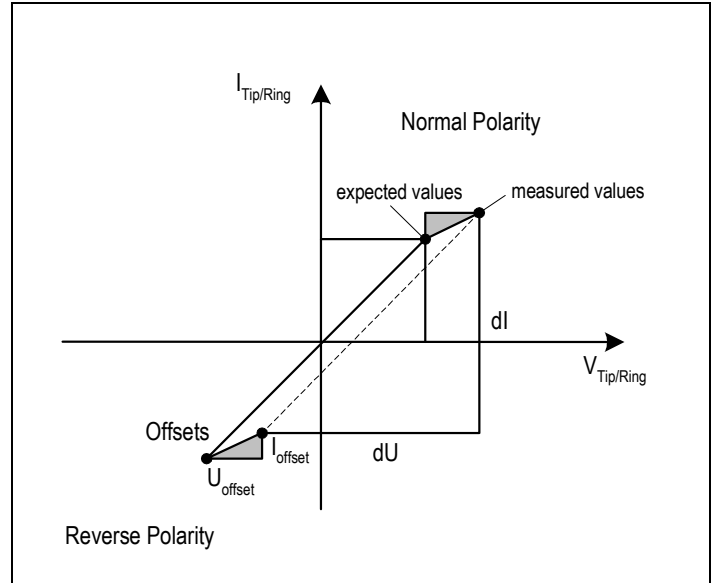

Figure - 25 Differential Resistance Measurement

This differential measurement method eliminates both the current offset caused by the RSLIC current sensor and the voltage offset caused by the DC voltage output (ring offset voltage). The following calculation shows the elimination of both offsets.

$$I_{Measure(normal)} = \frac{V_{TRDC} + V_{Offset} + I_{Offset}}{R_{Loop}}$$

$$I_{Measure(reverse)} = \frac{-V_{TRDC} + V_{Offset} + I_{Offset}}{R_{Loop}}$$

$$I_{Measure(normal)} - I_{Measure(reverse)} = \frac{2 \times V_{TRDC}}{R_{Loop}}$$

$$R_{Loop} = \frac{2 \times V_{TRDC}}{I_{Measure(normal)} - I_{Measure(reverse)}} = R_{LINE} + R_{Sense} + R_{PROT}$$

V_{Offset} : offset voltage caused by the DC voltage output;

I_{Offset} : offset current caused by the RSLIC current sensor;

3.9.6.4 Line Resistance Tip/GND and Ring/GND

The line resistance Tip/GND and Ring/GND can be measured by setting the Ring and Tip lines to high impedance respectively. When one line is set to high impedance, the other line is still active and is able to supply a known voltage. By measuring the DC transversal current, the line impedance can be determined.

Because one line (Tip or Ring) is high impedance, there is only current flowing through the other line. This causes the calculated current to be half of the actual value. Therefore in either Ring Open or Tip Open mode the calculated current must be multiplied by a factor of 2.

$$R_{Tip|GND} = V_{TGDC} / \left(\frac{LM_{Result} \times 2}{K_{ADDC} \times K_{INT} \times N_{Samples} \times K_{ITDC}} \right)$$

$$R_{Ring|GND} = V_{RGDC} / \left(\frac{LM_{Result} \times 2}{K_{ADDC} \times K_{INT} \times N_{Samples} \times K_{ITDC}} \right)$$

V_{TGDC} : DC voltage applied to Tip/GND

V_{RGDC} : DC voltage applied to Ring/GND.

3.9.6.5 Capacitance Measurement

• Ramp Generator

The RSLIC-CODEC chipset integrates a ramp generator to help to measure the capacitance. The ramp generator can generate required voltage ramps to feed to the Ring and Tip lines. Figure - 26 shows the voltage ramp and the voltage levels at the Ring and Tip lines.

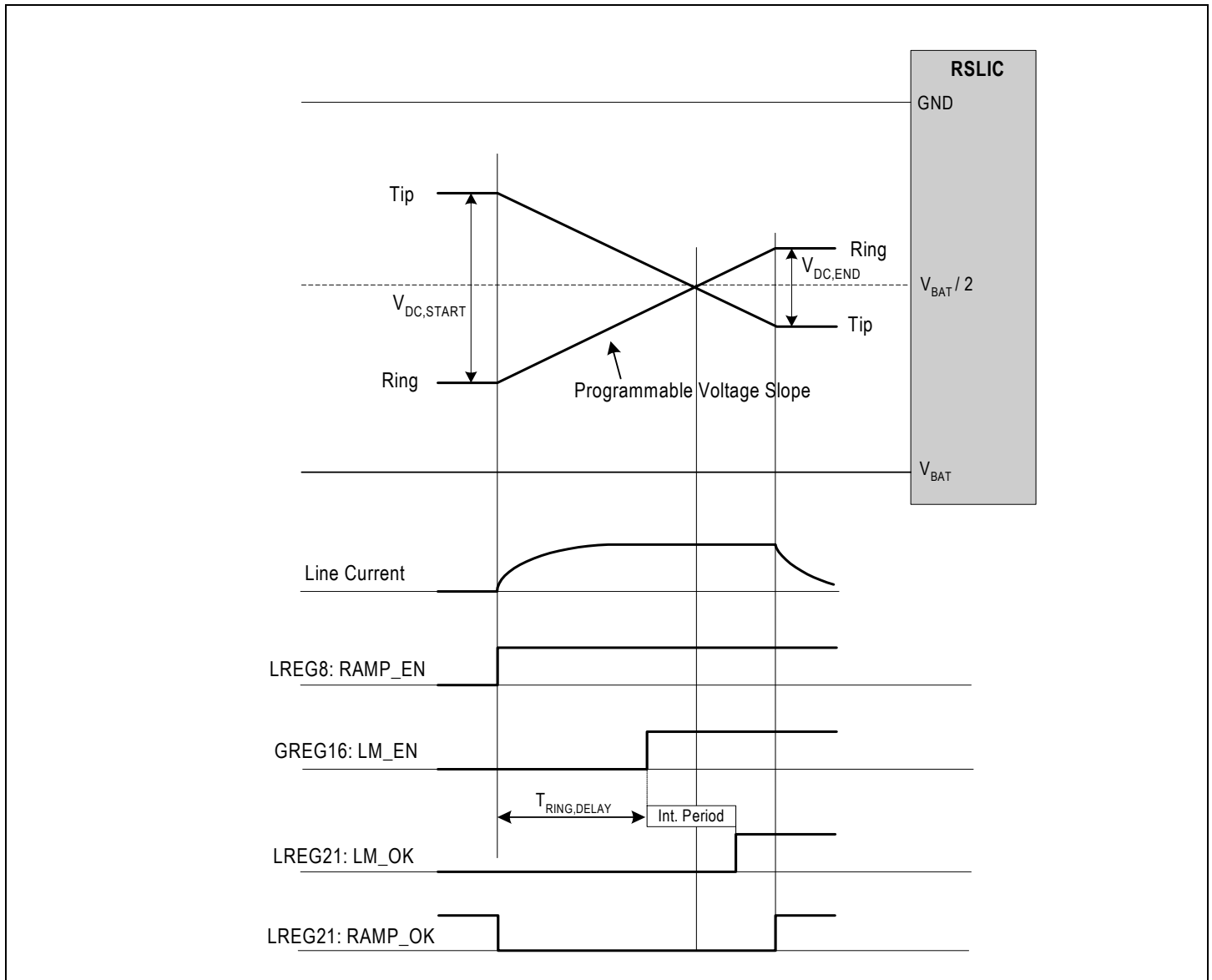

Figure - 26 Capacitance Measurement

The ramp generator is programmable by the Coe-RAM:

- Slope is programmable from 20 to 2000 V/s by word RampSlope;
- Start voltage is programmable from -70 to 70 V by word RingOffset;
- End voltage is programmable from -70 to 70 V by word RampEnd.

The following settings are necessary to generate a ramp signal:

1. Set the CODEC operating mode to RAMP (for both MPI and GCI interfaces, LREG6: RAMP = 1).

2. Set the RSLIC operating mode to Internal Ring (for MPI interface, LREG6: SCAN_EN = 1, SM[2:0] = 010; for GCI interface, downstream C/I channel: SCAN_EN = 1, SM[2:0] = 010).
3. Select desired ramp start voltage, end voltage and slope (LREG5: RG = 1, constant parameters for the ramp are selected; LREG5: RG = 0, ramp parameters are programmed by the Coefficient RAM, refer to Table - 23 on page 62 for details).

4. Enable the ramp generator (LREG8: RAMP_EN = 1).

Once the RAMP_EN bit is set to 1, a ramp signal will start from the start voltage and increases its voltage following the programmed slope. When the voltage of the ramp signal finally reaches the programmed end voltage, the RAMP_OK bit in LREG21 will be set to indicate that the

ramp generation is finished. An interrupt will be generated simultaneously if the ramp mask bit RAMP_M in LREG18 is 0.

Table - 18 lists the registers and Coe-RAM locations used for ramp generation.

Table - 18 Registers and Coe-RAM Locations Used for Ramp Generator

Parameter	Register Bits/Coe-RAM Words	Notes
Ramp Parameters Selection	Bit RG in LREG5	RG = 0: The ramp slope, start voltage and end voltage in the Coe-RAM are selected. RG = 1: The ramp slope, start voltage and end voltage in the ROM are selected (default);
Ramp Start Voltage	Word RingOffset in the Coe-RAM	Programmable from -70 V to 70 V with $\pm 1\%$ tolerance. The default value in the ROM is 7 V.
Ramp Slope	Word RampSlope in the Coe-RAM	Programmable from 20 V/s to 2000 V/s with $\pm 1\%$ tolerance. The default value in the ROM is 300 V/s.
Ramp End Voltage	Word RampEnd in the Coe-RAM	Programmable from -70 V to 70 V with $\pm 1\%$ tolerance. The default value in the ROM is 20 V.
Ramp Mode Selection	Bit RAMP in LREG6	The ramp signal can only be generated in the RAMP mode (RAMP = 1).
Ramp Generator Enable	Bit RAMP_EN in LREG8	RAMP_EN = 0: The ramp generator is disabled; RAMP_EN = 1: The ramp generator is enabled.
Ramp Over Indication	Bit RAMP_OK in LREG21	RAMP_OK = 0: The ramp generation is in progress; RAMP_OK = 1: The ramp generation is finished.
Mask bit for RAMP_OK	Bit RAMP_M in LREG18	RAMP_M = 0: An interrupt will be generated when the RAMP_OK bit changes from 0 to 1; RAMP_M = 1: Interrupts will not be generated when the RAMP_OK bit changes.

• Capacitance Measurement

The sequence of capacitance measurement is as the following (also refer to Figure - 26):

1. Configure the ramp generator (program the ramp slope, start voltage and end voltage);
2. Select the VTDC voltage to the DC level meter;
3. Configure the level meter integrator (GREG16: LM_ONCE = 1);
4. Enable the ramp generator (LREG8: RAMP_EN = 1);
5. After the current has settled, enable the level meter (GREG16: LM_EN = 1).

(Note: The ramp voltage starts at RingOffset and ramps up/down until RampEnd is reached. When the integration is finished, the result will be stored in registers GREG17 and GREG18).

6. Read the result in GREG17 and GREG18.

The actual current can be calculated as: $i(t) = C_{Measure} \times dU/dt$

Where, dU/dt is the ramp slope and $i(t)$ is the current measured by the level meter. The capacitance then can be calculated as:

$$C_{Measure} = \frac{i(t)}{(du)/(dt)} = \left(\frac{LM_{Result}}{K_{ADDC} \times K_{INT} \times N_{Samples} \times K_{ITDC}} \right) / \left(\frac{du}{dt} \right)$$

To ensure measurement accuracy, the level meter integrator must be enabled after the current has settled to a constant value. The integration time is programmed by the LM_CN[10:0] bits in GREG15 and GREG16.

3.9.6.6 Voltage Measurement

The DC level meter can measure the following voltages:

- External voltage Tip/GND (through IO4 pin)
- External voltage Ring/GND (through IO3 pin)
- External voltage Tip/Ring (through IO4 -IO3)
- Ringing voltage (through IO4 -IO3)
- Supply voltage VDD of the CODEC

The two programmable IO pins (IO3 and IO4) with analog input

functionality can be used to measure external voltages. If IO3 and IO4 pins are connected properly over a voltage divider to the Ring and Tip lines, the external voltage supplied to the lines can be measured on either IO3 or IO4 pin, or on IO4-IO3 (differential measurement). The LM_SEL[3:0] bits in LREG9 select an external voltage to be measured. Refer to Table - 13 on page 40 for details.

Figure - 27 shows the connection and external resistors used for external voltage measurements at the Ring and Tip lines.

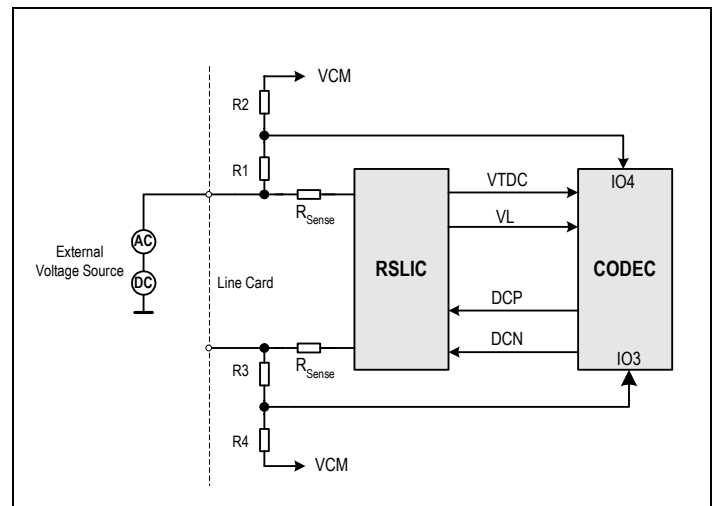

Figure - 27 External Voltage Measurement Principle

The voltage measured on IO3, IO4 or IO4-IO3 is as follows (with a reference to VCM):

$$V_{IO4} = \frac{LM_{Result}}{K_{ADDC} \times K_{INT} \times N_{Samples}} + VCM$$

$$V_{IO3} = \frac{LM_{Result}}{K_{ADDC} \times K_{INT} \times N_{Samples}} + VCM$$

$$V_{IO4-IO3} = \frac{LM_{Result}}{K_{ADDC} \times K_{INT} \times N_{Samples}}$$

In Figure - 27, if $R_1 = R_3$, $R_2 = R_4$, the external voltage can be calculated as:

$$V_{TipIGND} = \frac{R_1 + R_2}{R_2} \times (V_{IO4} - VCM) + VCM$$

$$V_{RingIGND} = \frac{R_1 + R_2}{R_2} \times (V_{IO3} - VCM) + VCM$$

$$V_{TipIRing} = \frac{R_1 + R_2}{R_2} \times (V_{IO4} - V_{IO3})$$

When measuring the ringing voltage, the following steps are necessary:

- Set the level meter integration time (LM_CN[10:0] bits in GREG15 and GREG16) to be an integer multiple of the period of measured ringing signal.
- Clear the Offset Register (word DC Offset in the Coe-RAM).
- Measure the DC content with the rectifier disabled.
- Read the result (LM_{Value}) from the result registers and write the following offset value to the Offset Register:

$$OFFSET = \frac{LM_{Value}}{N_{Samples} \times K_{INT}}$$

- Repeat the measurement above should result in LM_{Value} to be zero.
- Perform a new measurement with the rectifier enabled. The result is the rectified mean value of the measured signal and can be calculated as:

$$|V|_{mean} = \frac{LM_{Result} \times K_{ITDC} \times R_{Sense}}{K_{ADDC} \times K_{INT} \times N_{Samples}}$$

- From this result the peak value and the RMS value can be calculated.

$$V_{Peak} = \frac{|V|_{mean} \times \pi}{2}$$

$$V_{RMS} = \frac{V_{Peak}}{\sqrt{2}} = \frac{LM_{Result} \times K_{ITDC} \times R_{Sense} \times \pi}{K_{ADDC} \times K_{INT} \times N_{Samples} \times 2 \times \sqrt{2}}$$

The power supply of the CODEC (VDD) can be measured by selecting the VDD voltage to the DC level meter. When measuring the VDD voltage, an internal gain stage (gain = 1/2) is used to divide the VDD voltage and provide a limited voltage to the level meter. The VDD is measured with a reference to VCM.

$$VDD = \left(\frac{LM_{Result}}{K_{ADDC} \times K_{INT} \times N_{Samples}} + VCM \right) \times 2$$

3.9.6.7 Voltage Offset Measurement

The filter, A/D conversion and decimation stages in the DC level meter may cause a voltage offset error. When selecting the VCM voltage as the source to the DC level meter, the voltage offset can be measured. Once the offset value is determined, the offset error can be eliminated by writing an appropriate compensation value to the Offset Register (word DC Offset in the Coe-RAM).

3.9.6.8 Ring Trip Operational Amplifier Offset Measurement

In external ringing mode, the sensed ring current signal is fed to an operational amplifier integrated in the RSLIC. The amplifier will output a signal to the CODEC through the RTIN pin for ring trip detection. But this amplifier may introduce an offset and affect the ring trip detection result. The offset can be measured by selecting the RTIN as the source to the DC level meter. Refer to "3.4.2.1 Ring Trip Detection In External Ringing Mode" on page 25 for details.

4 INTERFACE

The RSLIC-CODEC chipset provides two different types of digital interfaces to connect the CODEC to the digital network. One is a PCM interface combined with a serial Microprocessor Interface (PCM/MPI), the other is a General Circuit Interface (GCI). The $\overline{\text{MPI/GCI}}$ pin of the CODEC is used to select the interface.

$\overline{\text{MPI/GCI}} = 0$: PCM/MPI interface is selected;

$\overline{\text{MPI/GCI}} = 1$: GCI interface is selected.

4.1 PCM/MPI INTERFACE

In PCM/MPI mode, the voice data and control data are separate and transmitted via the PCM interface and MPI interface respectively.

4.1.1 MPI CONTROL INTERFACE

In PCM/MPI mode, all the control information including internal registers configuring, coefficients programming and RSLIC controlling is transferred through the MPI control interface. This interface consists of four pins:

CCLK: Serial control interface clock, up to 8.192 MHz

$\overline{\text{CS}}$: Chip select pin. A low level on it enables the serial control interface

CI: Serial control data input pin, carrying the data from the master microprocessor to the CODEC.

CO: Serial control data output pin, carrying the data from the CODEC to master microprocessor.

All the data transmitted and received through the MPI interface is aligned in an 8-bit byte stream. The data transfer is synchronized to the CCLK signal. The contents of CI is latched on the rising edges of CCLK, while CO changes on the falling edge of CCLK. Before finish executing a command followed by data bytes, the device will not accept any new commands from CI. Setting the $\overline{\text{CS}}$ pin to high will terminate the data transfer sequence. Figure - 28 and Figure - 29 show the read operation timing and write operation timing of the MPI interface.

The CCLK is the only reference for the CI and CO pins. Its duty and frequency may not necessarily be standard.

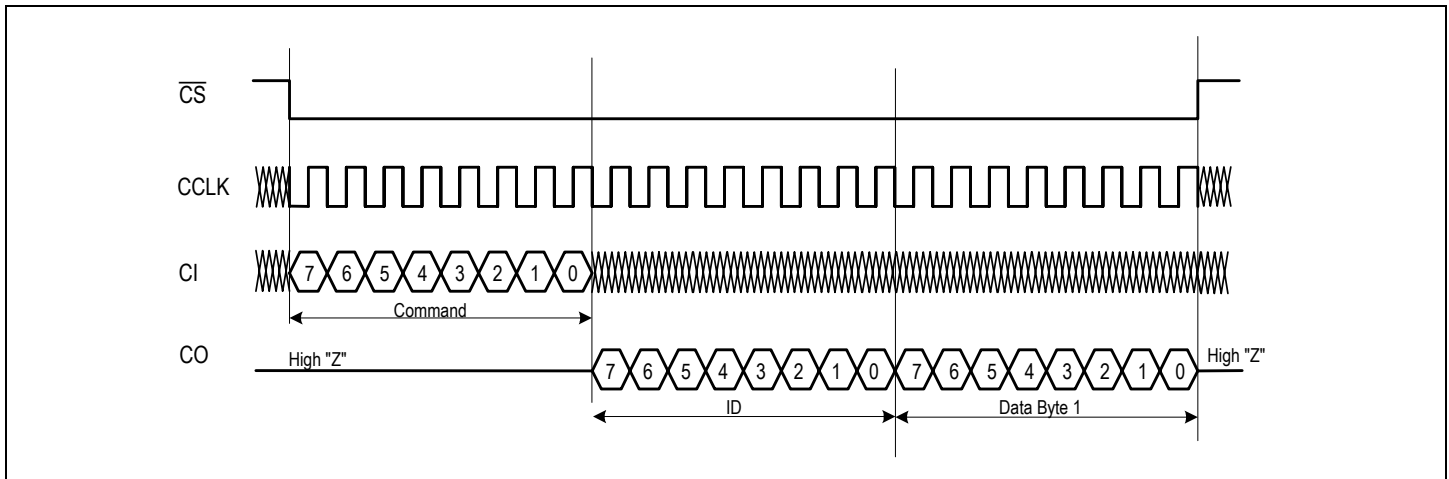

Figure - 28 MPI Read Operation Timing

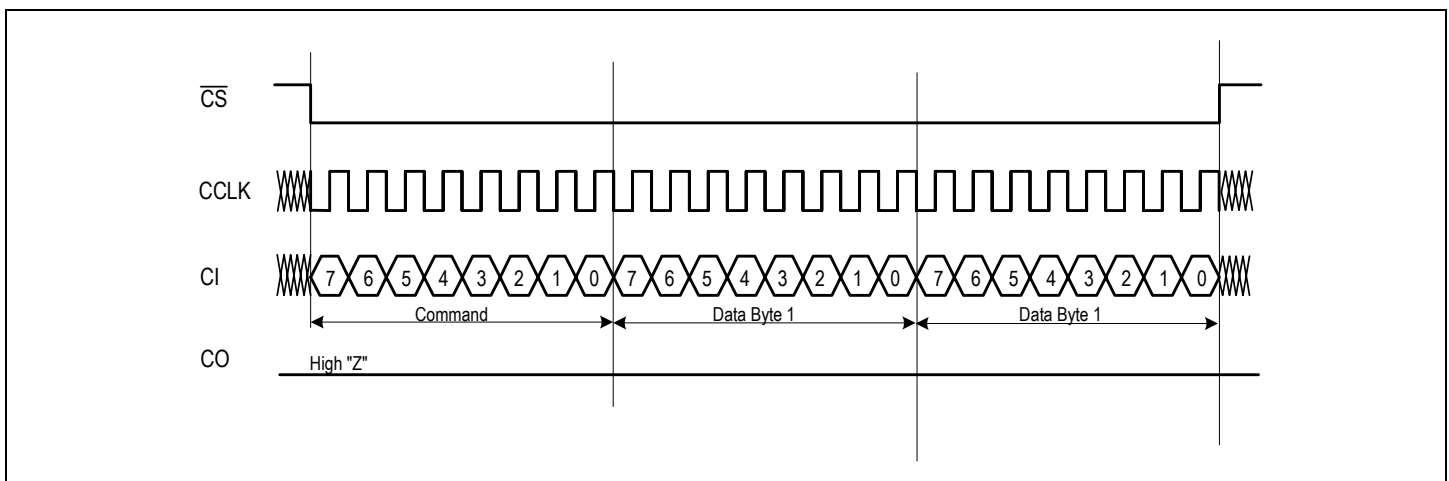

Figure - 29 MPI Write Operation Timing

4.1.2 PCM INTERFACE

In PCM/MPI mode, the PCM data (A/μ-law compressed code or linear code) is transferred through the PCM interface. The CODEC provides two transmit and two receive PCM highways for all four channels. The PCM interface consists of eight pins as shown below:

- FSC: frame synchronization clock
- BCLK: PCM bit clock
- DX1: PCM transmit data highway 1
- DR1: PCM receive data highway 1
- TSX1: PCM data transmit indicator 1, active low
- DX2: PCM transmit data highway 2
- DR2: PCM receive data highway 2
- TSX2: PCM data transmit indicator 2, active low

delay period programmable. As shown in Figure - 30, the data rate can be the same as the BCLK (single clock mode) or half of it (double clock mode). This is done by setting the DBL_CLK bit in register GREG3 to 0 and 1 respectively. The PCM clock slope is selected by the TR_SLOPE[1:0] bits in register GREG3.

The PCM data can be transmitted either on the rising edge or on the falling edge of the BCLK signal. If the BCLK signal is jitter free¹, the PCM data can be received either on the rising edge or on the falling edge. If the BCLK signal is not jitter free, please refer to the IDT82V1074 Application Note (AN-380) for details on the effective edge selection.

The time slots for transmitting and receiving data can be offset from the FSC signal by 0 to 7 BCLK period(s). The PCM_OFT[2:0] bits in GREG3 are used to set the offset period of the PCM timing.

4.1.2.1 PCM Clock Configuration

The PCM interface is flexible with the data rate, clock slope and

1. Jitter free means that the BCLK signal is from an independent oscillator or a system clock whose peak-to-peak jitter (> 4 kHz) is less than 0.01 UI.

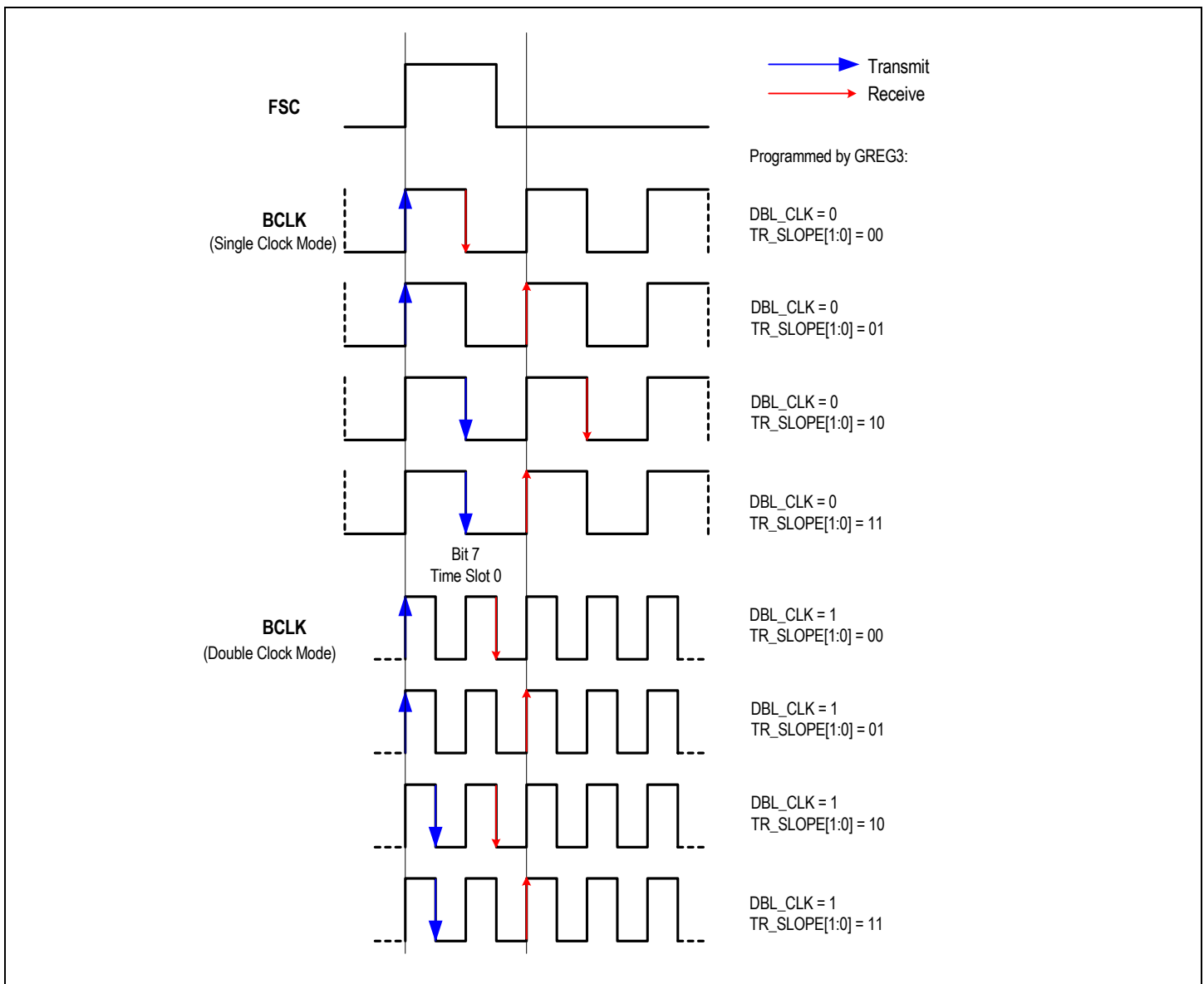

Figure - 30 PCM Clock Slope Select Waveform

4.1.2.2 Time Slot Assignment

The PCM data of each channel can be assigned to any time slot of the PCM highway. The number of the available time slots is determined by the BCLK frequency. If the BCLK frequency is f kHz, the number of the time slots that can be used is the result of f (kHz) divided by 64 kHz. For example, if the frequency of BCLK is 512 kHz, then a total of eight time slots are available. The CODEC accepts any BCLK signals ranging from 256 kHz to 8.192 MHz at increment of 64 kHz.

If the PCM data is A-law or μ -law compressed (8-bit), the voice data of one channel occupies one time slot. The TT[6:0] bits in LREG1 select the transmit time slot, while the RT[6:0] bits in LREG2 select the receive time slot. The THS bit in LREG1 selects the transmit highway (DX1 or DX2). The RHS bit in LREG2 selects the receive highway (DR1 or DR2).

For linear PCM data, which is a 16-bit 2's complement (b13 to b0 are data bits, while b15 and b14 are the same as the sign bit b13), one time slot group consisting of two successive time slots are needed to contain the voice data of one channel. The TT[6:0] bits in LREG1 select the transmit time slot group. For example, if the TT[6:0] bits are set to '0000000', it means that TS0 and TS1 are selected; if the TT[6:0] bits are set to '0000001', it means that TS2 and TS3 are selected. The RT[6:0] bits in LREG2 select the receive time slot group in the same way.

4.1.2.3 PCM Highway Selection

The PCM data of each channel is sent out to the PCM highway on the selected edges of the BCLK. The transmit highway (DX1 or DX2) is selected by the THS bit in LREG1. The frame sync signal (FSC) identifies the beginning (Time Slot 0) of a transmit frame. The PCM data is transmitted serially to DX1 or DX2 with MSB first.

The PCM data from the master processor is received via the PCM highway on the selected edges of the BCLK. The receive highway (DR1 or DR2) is selected by the RHS bit in LREG2. The PCM data is received serially from DR1 or DR2 with MSB first. The frame sync signal (FSC) identifies the beginning (Time Slot 0) of a receive frame.

4.2 GCI INTERFACE

The General Circuit Interface (GCI) defines an industry-standard serial bus for interconnecting telecommunication ICs for a broad range of applications – typically ISDN-based applications. The GCI bus provides a symmetrical full-duplex communication link containing data, control/programming and status channels. Providing data, control and status information via a serial channel simplifies the line card layout and reduces the cost.

The GCI interface consists of two data lines and two clock lines as follows:

- DU: Data Upstream carries data from the CODEC to the master processor
- DD: Data Downstream carries data from the master processor to the CODEC
- FSC: Frame Synchronization signal (8 kHz) supplied to the CODEC
- DCL: Data Clock signal (2.048 MHz or 4.096 MHz) supplied to the CODEC

The CODEC sends upstream data to the DU pin and receives downstream data via the DD pin. A complete GCI frame is sent upstream and received downstream every 125 μ s. The Frame Sync signal (FSC) identifies the beginning of the transmit and receive frames and all GCI time slots are referenced to it. The internal circuit of the

CODEC monitors the input DCL signal to determine which frequency (2.048 MHz or 4.096 MHz) is being used. The internal timing will be adjusted accordingly so that DU and DD operate at 2.048 MHz rate.

The CODEC allows both compressed and linear data format coding/decoding. The L_CODE bit in GREG3 selects the data format:

- L_CODE = 0: Compressed code (default)
- L_CODE = 1: Linear code

4.2.1 COMPRESSED GCI MODE

In GCI compressed mode, one GCI frame consists of 8 GCI time slots. In each GCI time slot, the data upstream interface transmits four 8-bit bytes. They are:

- Two voice data bytes from the A-law or μ -law compressor of two different channels, named channel A and channel B. The compressed voice data bytes for channel A and B are 8-bit wide:
 - One monitor channel byte, containing the control data/coefficients from/to the master device for channel A and B;
 - One C/I channel byte, which contains a 6-bit C/I sub-byte together with an MX bit and an MR bit. All real time signaling information is carried on the C/I sub-byte. The MX (Monitor Transmit) bit and MR (Monitor Receive) bit are used for handshaking functions for channel A and B. Both MX and MR are active low.

The transmit logic controls the transmission of data onto the GCI bus.

The downstream data structure is the same as that of upstream. The data downstream interface logic controls the reception of data bytes from the GCI bus. The two compressed voice data bytes of the GCI time slot are transferred to the A-law or μ -law expansion logic circuit. The expanded data is passed through the receive path of the signal processor. The Monitor Channel and C/I Channel bytes are transferred to the GCI control logic for process.

Figure - 31 shows the structure of the overall compressed GCI frame.

In GCI compressed mode, two GCI time slots are required to access all four channels of the CODEC. The GCI time slot assignment is determined by S1 and S0 pins as shown in Table - 19.

4.2.2 LINEAR GCI MODE

In GCI linear mode, one GCI frame consists of eight GCI time slots and each GCI time slot consists of four 8-bit bytes. Four of the eight GCI time slots are used as the monitor channel and C/I channel. They have a common data structure as follows:

- Two Don't Care bytes.
- One monitor channel byte, containing the control data/coefficients from/to the master device for channel A and B.
- One C/I channel byte, which contains a 6-bit C/I sub-byte together with an MX bit and an MR bit. All real time signaling information is carried on the C/I sub-byte. The MX (Monitor Transmit) bit and MR (Monitor Receive) bit are used for handshaking functions for channel A and B. Both MX and MR bits are active low.

The other four GCI time slots are used to contain the linear voice data (a 16-bit 2's complement number: b13 to b0 are data bits, while b15 and b14 are the same as the sign bit b13). Each GCI time slot consists of four bytes: two bytes for the 16-bit linear voice data of channel A, the other two bytes for the 16-bit linear data of channel B.

The GCI time slot assignment is determined by the S1 and S0 pins. When S0 and S1 are both low, the linear GCI frame structure is as shown in Figure - 32 on page 54.

In linear operation, for one chip of the four-channel CODEC occupies

four GCI time slots (two for voice data and two for C/I and monitor channels), the remaining four GCI time slots can be used by another chip if you were to tie their control busses together. Hence, for an 8-

timeslot GCI bus, there are four time slot locations for one CODEC to select. See [Table - 20 on page 54](#) for details.

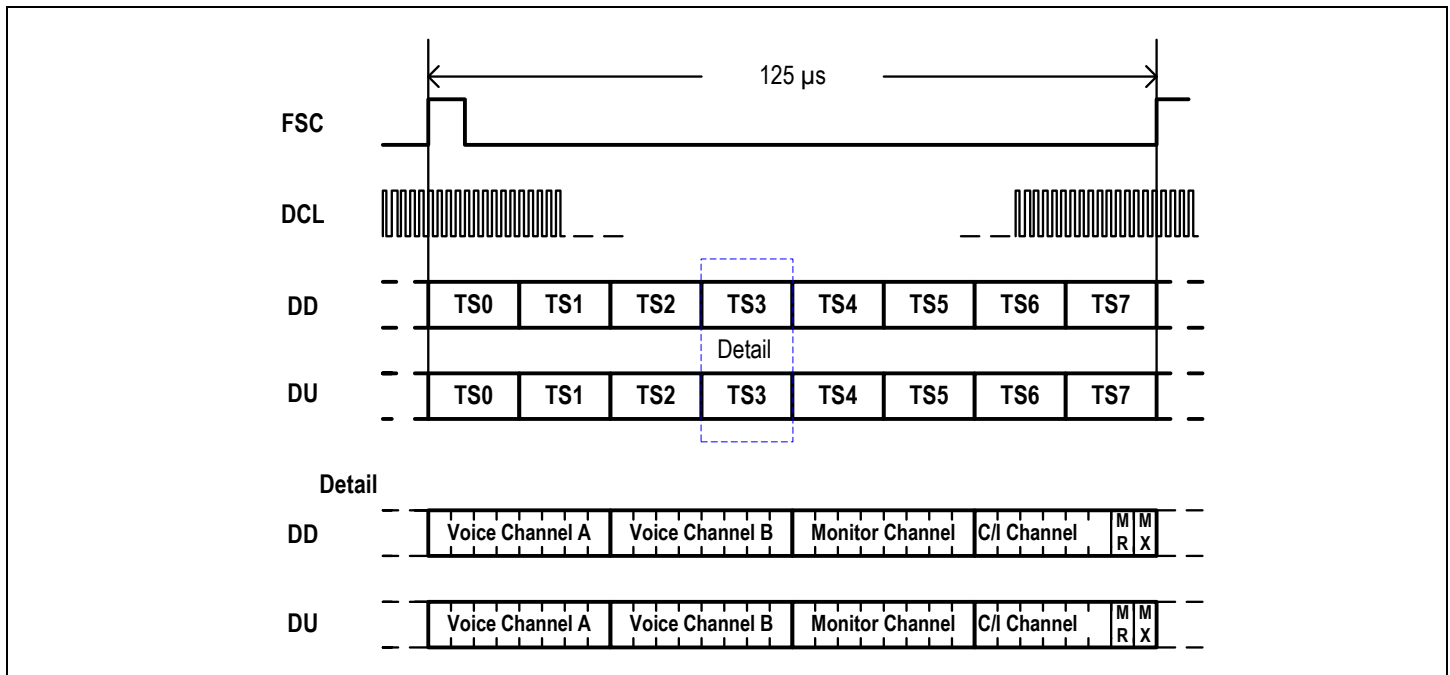

Figure - 31 Compressed GCI Frame Structure

Table - 19 Time Slot Selection For Compressed GCI

CODEC Channel	S1 = 0, S0 = 0		S1 = 0, S0 = 1		S1 = 1, S0 = 0		S1 = 1, S0 = 1	
	Time Slot	Voice Channel	Time Slot	Voice Channel	Time Slot	Voice Channel	Time Slot	Voice Channel
1	Time Slot 0	A	Time Slot 2	A	Time Slot 4	A	Time Slot 6	A
2	Time Slot 0	B	Time Slot 2	B	Time Slot 4	B	Time Slot 6	B
3	Time Slot 1	A	Time Slot 3	A	Time Slot 5	A	Time Slot 7	A
4	Time Slot 1	B	Time Slot 3	B	Time Slot 5	B	Time Slot 7	B

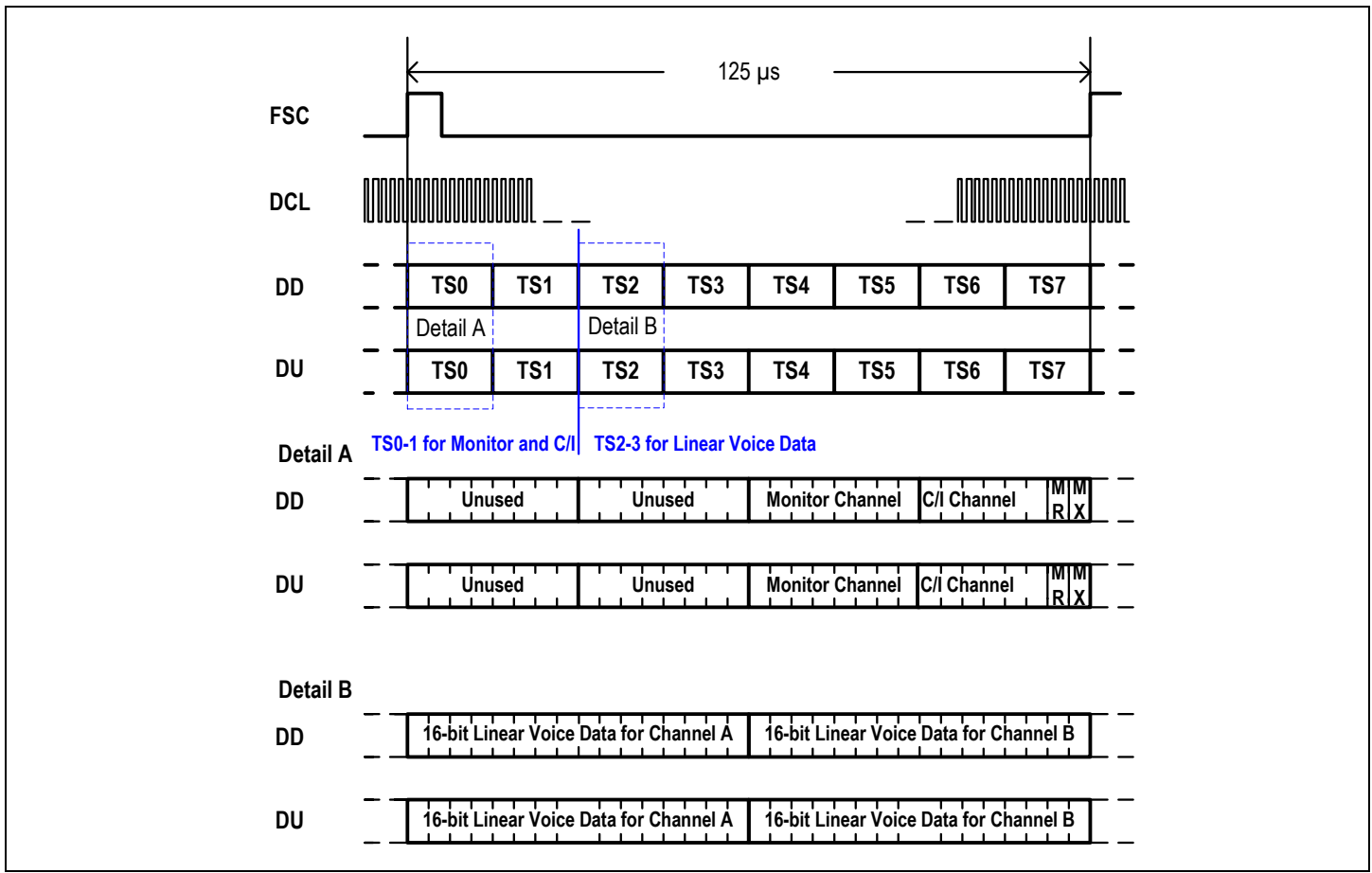

Figure - 32 Linear GCI Frame Structure

Table - 20 Time Slot Selection For Linear GCI

CODEC Channel	S1 = 0, S0 = 0				S1 = 0, S0 = 1			
	Time Slot	Monitor and C/I Channel	Time Slot	Voice Channel	Time Slot	Monitor and C/I Channel	Time Slot	Voice Channel
1	Time Slot 0	A	Time Slot 2	A	Time Slot 2	A	Time Slot 4	A
2	Time Slot 0	B	Time Slot 2	B	Time Slot 2	B	Time Slot 4	B
3	Time Slot 1	A	Time Slot 3	A	Time Slot 3	A	Time Slot 5	A
4	Time Slot 1	B	Time Slot 3	B	Time Slot 3	B	Time Slot 5	B
CODEC Channel	S1 = 1, S0 = 0				S1 = 1, S0 = 1			
	Time Slot	Monitor and C/I Channel	Time Slot	Voice Channel	Time Slot	Monitor and C/I Channel	Time Slot	Voice Channel
1	Time Slot 4	A	Time Slot 6	A	Time Slot 6	A	Time Slot 0	A
2	Time Slot 4	B	Time Slot 6	B	Time Slot 6	B	Time Slot 0	B
3	Time Slot 5	A	Time Slot 7	A	Time Slot 7	A	Time Slot 1	A
4	Time Slot 5	B	Time Slot 7	B	Time Slot 7	B	Time Slot 1	B

4.2.3 COMMAND/INDICATION (C/I) CHANNEL

The downstream and upstream command/indication (C/I) channels are continuously (every frame) carrying I/O information to and from the CODEC. Real-time signaling information for the two channels (A & B) are transferred via the six C/I bits. The two least significant bits of the C/I bytes (MR and MX) are handshaking bits for the monitor channel. The CODEC transmits or receives the C/I channel data with the most significant bit first.

4.2.3.1 Downstream C/I Channel Byte

The downstream C/I channel byte is used to control the operating mode of the RSLIC. This byte is defined as:

Downstream C/I Channel Byte							
MSB						LSB	
C _A	C _B	SCAN_EN	SM[2]	SM[1]	SM[0]	MR	MX

This byte is shared by two channels (A & B) to transfer information. The C_A and C_B bits indicate whether the current C/I byte is for Channel A or Channel B respectively:

C_A = 1: the control information carrying by the SCAN_EN and SM[2:0] bits is for Channel A.

C_B = 1: the control information carrying by the SCAN_EN and SM[2:0] bits is for Channel B.

The SM[2:0] bits are used to configure the operating mode of the respective RSLIC. The SCAN_EN bit in this byte determines whether the corresponding RSLIC will be accessed. Refer to “6.1.2 RSLIC Operating Modes” on page 89 for detailed information. By properly program the downstream C/I channel byte, users can configure the operating mode of every channel as required.

4.2.3.2 Upstream C/I Channel Byte

The upstream C/I channel byte quickly transfers the most time-critical information from the chipset to the master device. The definition of this byte is as follows:

Upstream C/I Channel Byte							
MSB						LSB	
INT_CHA	HOOKA	GNDKA	INT_CHB	HOOKB	GNDKB	MR	MX

The six C/I bits in this byte is illustrated below:

HOOKA: hook state of channel A

HOOKA = 0: channel A is on-hook

HOOKA = 1: channel A is off-hook

HOOKB: hook state of channel B

HOOKB = 0: channel B is on-hook

HOOKB = 1: channel B is off-hook

GNDKA: ground-key information of channel A

GNDKA = 0: no longitudinal current is detected in channel A

GNDKA = 1: longitudinal current is detected in channel A

GNDKB: ground-key information of channel B

GNDKB = 0: no longitudinal current is detected in channel B

GNDKB = 1: longitudinal current is detected in channel B

INT_CHA: interrupt information of channel A

INT_CHB: interrupt information of channel B

The valid polarity of INT_CHA and INT_CHB depends on the INT_POL bit in GREG24:

INT_POL = 0: active low (default)

INT_POL = 1: active high

4.2.4 GCI MONITOR TRANSFER PROTOCOL

4.2.4.1 Monitor Channel Operation

In GCI mode, upstream processors access the registers and RAM of the chipset via the monitor channel. Using two monitor control bits MR

and MX per direction (the MR and MX bits are contained in the C/I channel bytes), data is transferred between the upstream and downstream devices in a complete handshake procedure. [Figure - 33](#) shows the monitor channel operating diagram.

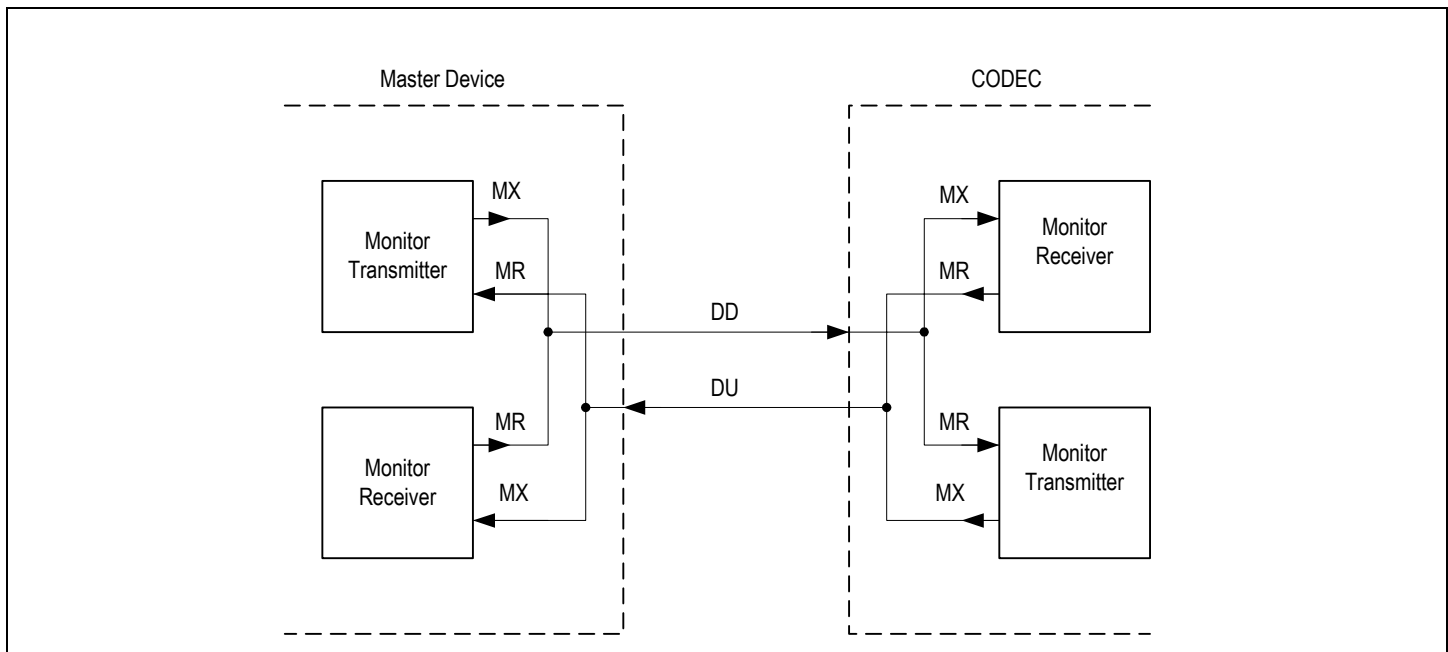

Figure - 33 Monitor Channel Operation

The transmission of the monitor channel is operated on a pseudo-asynchronous basis:

- Data transfer (bits) on the bus is synchronized to FSC;
- Data flow (bytes) are asynchronously controlled by the handshake procedure.

For example: Data is placed onto the DD Monitor Channel by the Monitor Transmitter of the master device (DD MX bit is activated and set to 0). This data transfer will be repeated within each frame (125 μ s rate) until it is acknowledged by the CODEC Monitor Receiver by setting the DU MR bit to 0. Because of the handshaking protocol required for successful communication, the data transfer rate using the monitor channel is less than 8 kbit/s.

4.2.4.2 Monitor Handshake Procedure

The monitor channel works in three states:

I. Idle state: Both the MR and MX bits are inactive ('1') during two or more consecutive frames signals an idle state on the monitor channel or an end of message (EOM);

II. Sending state: The MX bit is activated ('0') by the Monitor Transmitter, together with a data byte (can be changed) on the monitor channel;

III. Acknowledging: The MR bit is set to active state ('0') by the Monitor Receiver, together with a data byte remaining in the monitor channel.

A start of transmission is initiated by a monitor transmitter by sending out an active MX bit ('0') together with the first byte of data to be transmitted in the monitor channel. This state remains until the addressed monitor receiver acknowledges the receipt of data by

sending out an active MR bit ('0'). The data transmission is repeated each 125 μ s frame (minimum is one repetition). During this time the Monitor Transmitter keeps detecting the MR bit.

Flow control, means in the form of transmission delay, can only take place when the transmitter's MX bit and the receiver's MR bit are in active state.

On the receiver side, since the monitor data can be received at least twice (in two consecutive frames), a last look function is able to check for data errors. If two different bytes are received the receiver will wait for the receipt of two identical successive bytes.

On the transmitter side, a collision resolution mechanism is implemented to avoid two or more devices are trying to send data at the same time. The mechanism is realized by looking for the inactive ('1') phase of the MX bit and making a per bit collision check on the transmitted monitor data (check whether transmitted '1's are on the DU/DD line. The DU/DD line are open drain).

Any abort leads to a reset of the CODEC command stack, and the device is ready to receive new commands.

To obtain a maximum speed data transfer, the transmitter anticipates the falling edge of the receivers acknowledgment.

Due to the inherent programming structure, duplex operation is not possible. It is not allowed to send any data to the CODEC while transmission is active.

Note that each byte on the monitor channel must be sent twice at least according to the GCI monitor handshake procedure.

Refer to [Figure - 34](#) and [Figure - 35](#) for details about monitor handshake procedure.

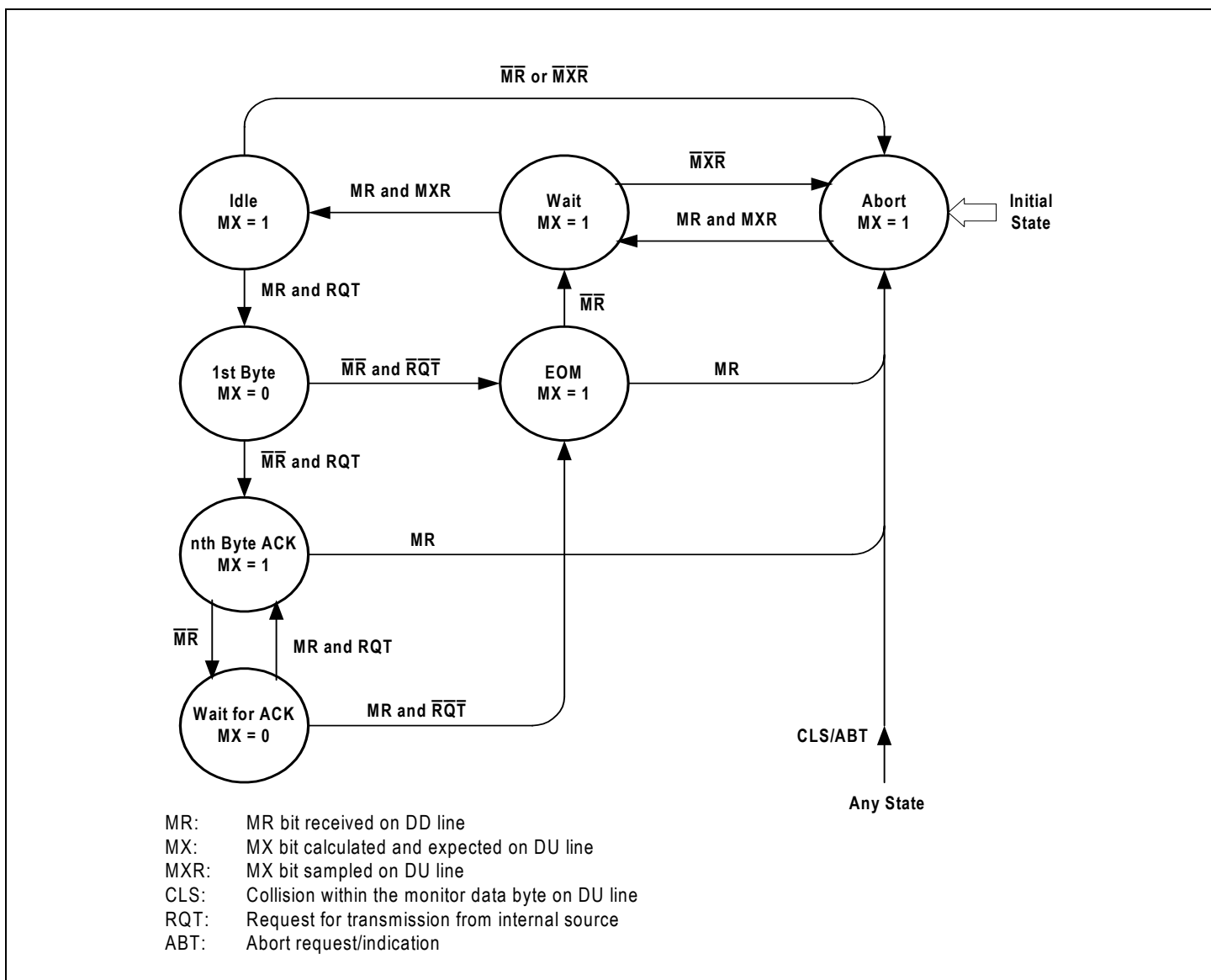

Figure - 34 State Diagram of the Monitor Transmitter

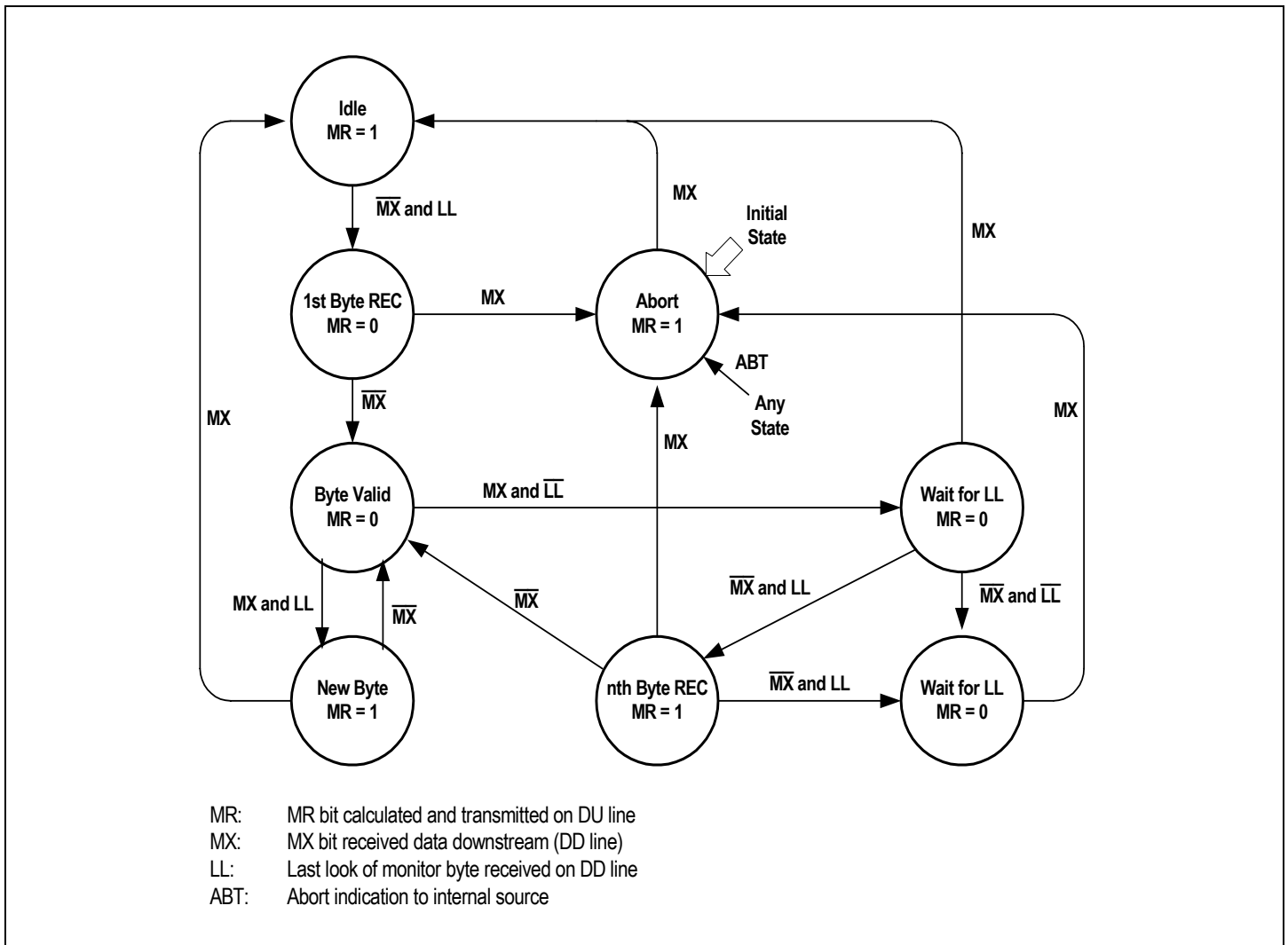

Figure - 35 State Diagram of the Monitor Receiver

By implementing proper register/RAM commands through the GCI monitor channel, users can flexibly control the RSLIC-CODEC chipset. The format and the addressing method of the register/RAM in both GCI mode and MPI mode are similar. Refer to "5.2 Register/RAM Commands" on page 59 for details.

4.3 ANALOG POTS INTERFACE

The interface between an analog Plain Old Telephone Service (POTS) and a RSLIC is shown in Figure - 49 on page 104. The RSLIC connects to the POTS interface through the TIP and RING pins. Over voltage and over current protectors connect to the TIP and RING pins

directly. Only two external resistors are needed to connect TIS to TIP and connect RIS to RING respectively, no other components are required in the POTS interface.

4.4 RSLIC AND CODEC INTERFACE

As Figure - 49 shows, the RSLIC can be connected directly to the CODEC.

The RSLIC can work in different modes that are determined by the CODEC through the SLIC mode control pins CSn and M1 to M3. Refer to "6 Operational Description" on page 87 for details.

5 PROGRAMMING

5.1 OVERVIEW

Programming the chipset is realized via the serial microprocessor interface (MPI mode) or GCI monitor channel (GCI mode). In MPI mode, the command or data is transferred via the CI/CO pin. In GCI mode, the command or data is transferred via the DD/DU pin.

5.1.1 MPI PROGRAMMING

5.1.1.1 Broadcast Mode for MPI Programming

A broadcast mode is provided for MPI write-operation (not allowed for read-operation). Each channel has its own Channel Enable bit (CH_EN[0] to CH_EN[3] in GREG4 for Channel 1 to Channel 4, respectively) to allow individual channel programming. If two or more CH_EN bits are set to 1 (enable), the corresponding channels are enabled and can receive the programming information simultaneously. Therefore, a broadcast mode can be implemented by simply enabling all of the channels in the device. The broadcast mode is very useful when initializing a large system, because the registers and RAM locations of four channels can be configured by one operation.

5.1.1.2 Identification Code for MPI Programming

In MPI mode, an identification code is used to distinguish the CODEC from other devices in the system. In read operations, before outputting other data bytes, the CODEC will first output an identification code of 81H indicating that the following data is from the CODEC.

5.1.2 GCI PROGRAMMING

5.1.2.1 Program Start Byte for GCI Programming

In GCI mode, the CODEC exchanges status and control information with the master processor through the monitor channel. The messages transferred in the monitor channel have different data structures. Since one monitor channel is shared by two voice data channels (channel A and channel B) to transfer status or control information, a Program Start (PS) byte is necessary to indicate the source (upstream) channel or the destination (downstream) channel during data transferring. For a complete GCI command operation, messages transferred via the monitor channel always start with a PS byte as follows:

b7	b6	b5	b4	b3	b2	b1	b0
1	0	0	\bar{A}/B	0	0	0	1

Where, the \bar{A}/B bit is used to identify the two channels:

$\bar{A}/B = 0$: 81H. channel A is the source (upstream) or destination (downstream).

$\bar{A}/B = 1$: 91H. channel B is the source (upstream) or destination (downstream).

The Program Start byte will be followed by a register command (global/local register command) or a RAM command (FSK-RAM or Coe-RAM command). For global register commands, the A/B bit in the PS byte is ignored.

5.1.2.2 Identification Command for GCI Programming

In order to distinguish different devices unambiguously by software, a two byte identification command of 8000H is defined for analog line GCI devices:

1	0	0	0	0	0	0	0
0	0	0	0	0	0	0	0

Each device will respond with its specific identification code. For the IDT82V1074, this two-byte identification code will be 8082H.

1	0	0	0	0	0	0	0
1	0	0	0	0	0	1	0

5.2 REGISTER/RAM COMMANDS

5.2.1 REGISTER/RAM COMMAND FORMAT

For both MPI and GCI modes, the command format is as the following:

b7	b6	b5	b4	b3	b2	b1	b0
\bar{R}/W	CT		Address				

\bar{R}/W : Read/Write Command bit
 b7 = 0: Read Command
 b7 = 1: Write Command

CT: Command Type
 b6 b5 = 00: Local Register Command
 b6 b5 = 01: Global Register Command
 b6 b5 = 10: FSK-RAM Command (one word operation)
 b6 b5 = 11: Coe-RAM Command (eight words operation)

Address: b[4:0] specify the register(s) or the location(s) of RAM to be addressed.

5.2.2 ADDRESSING THE LOCAL REGISTERS

In both MPI and GCI modes, the local registers are used to configure each individual channel. Up to 32 local registers are provided for each channel. The local registers are accessed by corresponding local commands.

• MPI Mode

In MPI mode, when addressing a local register, the Channel Enable Register (GREG5) must be first set to specify one or more channels to be addressed. For example, if the CH_EN[0] bit in GREG4 is set to 1, the local register(s) of channel 1 will be addressed. The CH_EN[1] to CH_EN[3] bits enable/disable the local registers of channel 2 to channel 4, respectively, in the same way.

In MPI mode, the CODEC provides an automatic countdown mechanism for addressing the local registers. When executing a local command, the CODEC will automatically count down from the address specified in b[4:0] to the address of 0. For example, if b[4:0] = 00001, the local register with the address of '00001' will be accessed first, then the address will be counted down to '00000' automatically and the corresponding local register will be accessed. Since the address is

'00000' now, the CODEC will stop counting down and the addressing operation is finished.

The number of the local registers addressed by a local command is $b[4:0]+1$. Hence, up to 32(d) local registers can be addressed by one local command. To apply a write local command, total $b[4:0]+1$ bytes of data should follow to ensure proper operation. See [Table - 21](#) for details.

Table - 21 Local Register Addressing in MPI Mode

Address Specified in a Local Command	In/Out Data Bytes	Address of the Local Registers to be accessed
$b[4:0] = 11111$	32 bytes	from '11111' to '00000'
$b[4:0] = 11110$	31 bytes	from '11110' to '00000'
$b[4:0] = 11101$	30 bytes	from '11101' to '00000'
...
$b[4:0] = 11000$	25 bytes	from '11000' to '00000'
$b[4:0] = 10111$	24 bytes	from '10111' to '00000'
$b[4:0] = 10110$	23 bytes	from '10110' to '00000'
$b[4:0] = 10101$	22 bytes	from '10101' to '00000'
...
$b[4:0] = 10000$	17 bytes	from '10000' to '00000'
$b[4:0] = 01111$	16 bytes	from '01111' to '00000'
$b[4:0] = 01110$	15 bytes	from '01110' to '00000'
$b[4:0] = 01101$	14 bytes	from '01101' to '00000'
...
$b[4:0] = 01000$	9 bytes	from '01000' to '00000'
$b[4:0] = 00111$	8 bytes	from '00111' to '00000'
$b[4:0] = 00110$	7 bytes	from '00110' to '00000'
$b[4:0] = 00101$	6 bytes	from '00101' to '00000'
...
$b[4:0] = 00000$	1 byte	'00000'

In MPI mode, when the \overline{CS} pin is pulled low, the CODEC treats the first byte present on the CI pin as command and the following byte(s) as data. To execute other commands, the \overline{CS} pin must be changed from low to high to finish the previous command and then be changed from high to low to start the next command.

The automatic count-down procedure can be stopped by the \overline{CS} pin at any time. If the \overline{CS} pin changes from low to high during a addressing process, the operation for current local register and the rest local registers will be aborted. But the operations accomplished before the \overline{CS} pin goes high will have already been executed.

To complete an automatic countdown procedure, the \overline{CS} pin must remain low for more than one data byte period after the last data byte is transmitted.

Refer to [“5.4.1.1 Example of Programming the Local Registers via MPI” on page 83](#) for more information.

- **GCI Mode**

In GCI mode, the b4 bit in the Program Start byte, together with the

location of the time slot (determined by the S0 and S1 pin), specifies the local registers to be addressed.

In GCI mode, the CODEC provides a consecutive adjacent addressing method for reading and writing local registers. According to the value of $b[1:0]$ specified in the local command, there will be one to four adjacent local registers to be addressed automatically with the highest order one first. For example, if the address bits $b[4:0]$ are set to 'XXX11' in a local command, the CODEC will count down from the address 'XXX11' to the address 'XXX00' automatically. The number of local registers to be addressed by one local command is $b[1:0]+1$. Therefore, up to four local registers can be addressed by one local command in GCI mode. Refer to [Table - 22](#) for details.

Table - 22 Local Register Addressing in GCI Mode

Address Specified in a Local Command	In/Out Data Bytes	Address of the Local Registers to be accessed
$b[4:0] = XXX11$	byte 1	XXX11
	byte 2	XXX10
	byte 3	XXX01
	byte 4	XXX00
$b[4:0] = XXX10$	byte 1	XXX10
	byte 2	XXX01
	byte 3	XXX00
$b[4:0] = XXX01$	byte 1	XXX01
	byte 2	XXX00
$b[4:0] = XXX00$	byte 1	XXX00

In GCI mode, the procedure of the consecutive adjacent addressing can not be stopped once a command is initiated. For a write operation, the number of the data bytes that follow the command byte must be the same as the number of the registers to be written.

Refer to [“5.4.2.1 Example of Programming the Local Registers via GCI” on page 85](#) for details.

5.2.3 ADDRESSING THE GLOBAL REGISTERS

In both MPI and GCI modes, the global registers are used to configure all four channels. The CODEC provides 32 global registers for all channels. The global registers are accessed by the corresponding global commands.

- **MPI Mode**

In MPI mode, the global registers are shared by all four channels, and there is no need to specify a channel or channels before addressing global registers. Except for this, the global registers are addressed in a similar manner as the local registers. See [“5.4.1.2 Example of Programming the Global Registers via MPI” on page 84](#) for details.

- **GCI Mode**

In GCI mode, the global command can be transferred during any of the GCI time slots and all four channel will receive it. Except for this, the global registers are addressed in a similar manner as the local registers. See [“5.4.2.2 Example of Programming the Global Registers via GCI” on page 85](#) for details.

5.2.4 ADDRESSING THE FSK-RAM

When sending a Caller ID message via FSK signal, the message

data is stored in the FSK-RAM that is shared by all four channels. The FSK-RAM consists of 32 words, 16 bits (two bytes) per word. They are addressed by the FSK-RAM commands.

The b[4:0] bits in a FSK-RAM command specify a location in the FSK-RAM to be accessed. In both MPI and GCI modes, when addressing a FSK-RAM word, 16 bits will be written to or read out from this word with MSB first.

- **MPI Mode**

In MPI mode, the FSK-RAM is addressed in a similar manner as the local registers except the data is twice as long. When executing a FSK-RAM command, the CODEC automatically counts down from the address specified in the command (b[4:0]) to the address of '00000', resulting in total b[4:0]+1 words of FSK-RAM being addressed. As the data written to or read out from the FSK-RAM is 16-bit (two-byte) wide, total (b[4:0]+1)* 2 bytes of data will follow a FSK-RAM command. Refer to [“5.4.1.4 Example of Programming the FSK-RAM via MPI” on page 84](#) for more information.

- **GCI Mode**

In GCI mode, the FSK-RAM is addressed in a similar manner as the local registers except the data is twice as long (the data for the FSK-RAM is 16-bit wide while the data for local registers is 8-bit wide). Refer to [“5.4.2.4 Example of Programming the FSK-RAM via GCI” on page 86](#) for more information.

5.2.5 ADDRESSING THE COE-RAM

The Coe-RAM (Coefficient RAM) consists of 12 blocks per channel, and each block consists of 8 words. So, there are total 96 words per channel. The coefficient RAM mapping is shown in [Table - 23](#).

Each word in Coe-RAM is 14-bit wide. To write a Coe-RAM word, 16 bits (or two 8-bit bytes) are needed to fill one word with MSB first, but the first two bits (MSB) will be ignored. When being read, each Coe-RAM word will output 16 bits with MSB first, but the first two bits are meaningless.

- **MPI Mode**

In MPI mode, the Coe-RAM commands always follow the Channel Enable command that specifies which channel(s) to be accessed.

The address (b[4:0]) in the Coe-RAM commands indicates which block of the Coe-RAM for the specified channel(s) will be addressed. The CODEC automatically counts down from the highest address to the lowest address of the specified block. So one block (consists of eight words) can be addressed by one Coe-RAM Command.

In MPI mode, the procedure of reading/writing words from/to the Coe-RAM can be stopped by the \overline{CS} pin at any time. When the \overline{CS} pin changes from low to high, the operation on the current word and the next adjacent words will be aborted. But the operations that are accomplished before the \overline{CS} pin goes high have been executed.

See [“5.4.1.3 Example of Programming the Coefficient-RAM via MPI” on page 84](#) for detailed information.

- **GCI Mode**

In GCI mode, both the location of time slot (determined by S1 and S0 pin) and the b4 bit in Program Start byte specify a channel of which the Coe-RAM will be addressed. The address (b[4:0]) in the Coe-RAM Command locates a block of the Coe-RAM. When executing a Coe-RAM Command, all eight words in the block will be read/written automatically, with the highest order word first.

In GCI mode, the procedure of the consecutive adjacent addressing can not be stopped once a Coe-RAM command is initiated.

See [“5.4.2.3 Example of Programming the Coefficient-RAM via GCI” on page 85](#) for details.

Table - 23 Coefficient RAM Mapping

Word 7	Word 6	Word 5	Word 4	Word 3	Word 2	Word 1	Word 0	Offset/Address	Notes
DC Offset (default value: 0)	Reserved		Impedance Matching Filter (IMF) Coefficient (default: the IMF is disabled)					00H	Block 0
Reserved	Transhybrid Balance Filter (ECF) Coefficient (default: the ECF is disabled)						01H	Block 1	
Gain for Impedance Scaling (GIS) (default value: 0)	Reserved		Should be 2000H when using the dual tone generators. (default: 0000H) ⁽¹⁾	TG2Freq (default: 1447 Hz)	TG2Amp (default: 0.94 V)	TG1Freq (default: 852 Hz)	TG1Amp (default: 0.94 V)	02H	Block 2
Digital Gain in Transmit Path (GTX) (default: 0 dB)	Coefficient for Frequency Response Correction in Transmit Path (FRX) (default: the FRX is disabled)						03H	Block 3	
Digital Gain in Receive Path (GRX) (default: 0 dB)	Coefficient for Frequency Response Correction in Receive Path (FRR) (default: the FRR is disabled)						04H	Block 4	
Reserved			RampEnd (default: 20 V)	RampSlope (default: 300V/S)	RingOffset (default: 7 V)	RingFreq (default: 30 Hz)	RingAmp (default: 40 V)	05H	Block 5
DC Feeding Coefficient								06H	Block 6
Reserved			HKHyst (default: 2 mA)	RTthld_AC (default: 5 mA)	RTthld_DC (default: 5 mA)	Reserved	HKthld (default: 7 mA)	07H	Block 7
UTD Integrator Coefficient	UTD Bandstop Filter Coefficient ⁽²⁾				UTD Bandpass Filter Coefficient ⁽²⁾			08H	Block 8
Reserved	UTDthld_Floor (default: -18 dBm)	UTDthld_Ceiling (default: -6 dBm)	Reserved				UTD Integrator Coefficient	09H	Block 9
LM Notch Filter Coefficient ⁽³⁾					Reserved			0AH	Block 10
LM Bandpass Filter Coefficient ⁽³⁾					Reserved			0BH	Block 11

Notes:

1. The default value of this word is 0000H. When using the dual tone generators, users should write 2000H (i.e. high byte: 20H, low byte: 00H) to this word to ensure proper operation.
2. When the gains in the transmit and receive paths are 0 dB, the default parameters of the UTD filters are as follows:
bandpass filter: center frequency is 2100 Hz and bandwidth is 60 Hz.
bandstop filter: center frequency is 2100 Hz and bandwidth is 230 Hz.
3. When the gains in the transmit and receive paths are 0 dB, the default parameters of the level meter filter are as follows:
bandpass/notch filter: center frequency is 1014 Hz and quality factor (Q) is 5.

5.3 REGISTERS DESCRIPTION

5.3.1 REGISTERS OVERVIEW

Table - 24 Global Registers Mapping

Name	Function Description	Register Byte								Read Command	Write Command	Default Value	
		b7	b6	b5	b4	b3	b2	b1	b0				
GREG1	PLL power down	PLL_PD	Reserved								20H	A0H	00H
GREG2	Reserved for future use	Reserved								-	-	-	
GREG3	PCM configuration	L_CODE	A/μ	DBL_CLK	TR_SLOPE[1:0]		PCM_OFT[2:0]			22H	A2H	40H	
GREG4	MCLK selection and channel enable	CH_EN[3:0]				MCLK_SEL[3:0]				23H	A3H	02H	
GREG5	Hardware/software reset and version information	HW_RST	Reserved	SW_RST	Reserved	RCH_SEL[3:0]				24H	A4H	00H	
GREG6	Loopback control	Reserved	ALB_64K	ALB_8K	ALB_DI	Reserved	DLB_64K	DLB_8K	DLB_DI	25H	A5H	00H	
GREG7	Three-party conference control	Reserved				CONF_EN	CONF_X_EN	CONF_CS[1:0]			26H	A6H	00H
GREG8	Gain of three-party conference	G_CONF[7:0]								27H	A7H	00H	
GREG9	Transmit highway and time slot selection for Part B	THS_B	TT_B[6:0]								28H	A8H	00H
GREG10	Receive highway and time slot selection for Part B	RHS_B	RT_B[6:0]								29H	A9H	00H
GREG11	Transmit highway and time slot selection for Part C	THS_C	TT_C[6:0]								2AH	AAH	00H
GREG12	Receive highway and time slot selection for Part C	RHS_C	RT_C[6:0]								2BH	ABH	00H
GREG13	Transmit highway and time slot selection for Part D	THS_D	TT_D[6:0]								2CH	ACH	00H
GREG14	Receive highway and time slot selection for Part D	RHS_D	RT_D[6:0]								2DH	ADH	00H
GREG15	Level meter configuration 1	LM_CN[7:0]								2EH	AEH	00H	
GREG16	Level meter configuration 2	LM_ONCE	LM_EN	LM_CS[1:0]		Reserved	LM_CN[10:8]			2FH	AFH	00H	
GREG17	Level meter result (low)	LMRL[7:0]								30H	-	00H	
GREG18	Level meter result (high)	LMRH[7:0]								31H	-	00H	
GREG19	FSK flag length	FSK_FL[7:0]								32H	B2H	00H	
GREG20	FSK data length	FSK_DL[7:0]								33H	B3H	00H	
GREG21	FSK seizure length	FSK_SL[7:0]								34H	B4H	00H	
GREG22	FSK mark length	FSK_ML[7:0]								35H	B5H	00H	
GREG23	FSK control	Reserved		FSK_CS[1:0]		FSK_EN	FSK_BS	FSK_MAS	FSK_TS	36H	B6H	00H	
GREG24	Interrupt polarity	Reserved			INT_POL	Reserved				37H	B7H	00H	
GREG25	Reserved for future use	Reserved								-	-	-	
GREG26	Off-hook, ground-key status and interrupt clear	GK[3]	HK[3]	GK[2]	HK[2]	GK[1]	HK[1]	GK[0]	HK[0]	39H	B9H	00H	

Table - 25 Local Registers Mapping

Name	Function Description	Register Byte								Read Command	Write Command	Default Value	
		b7	b6	b5	b4	b3	b2	b1	b0				
LREG1	Transmit highway and time slot selection	THS	TT[6:0]								00H	80H	00H for CH1 01H for CH2 02H for CH3 03H for CH4
LREG2	Receive highway and time slot selection	RHS	RT[6:0]								01H	81H	00H for CH1 01H for CH2 02H for CH3 03H for CH4
LREG3	Loopback control	Reserved	DLB_2M	DLB_PCM	Reserved	ALB_1MDC	ALB_2M	ALB_PCM	CUTOFF	02H	82H	00H	
LREG4	Coefficient selection	FRR	GRX	FRX	GTX	TG	ECF	IMF	DC_OFT	03H	83H	FFH	
LREG5	Coefficient selection	V90	HPF	LM_B	LM_N	UTD	Signaling	DC_FEED	RG	04H	84H	BFH	
LREG6	CODEC and RSLIC mode control	P_DOWN	STANDBY	ACTIVE	RAMP	SCAN_EN	SM[2:0]			05H	85H	80H	
LREG7	Analog Gain Selection, AC/DC Ring Trip Selection, Ring Generator and Tone Generators Enable	Reserved		IM_629	RING	RT_SEL	RING_EN	TG2_EN	TG1_EN	06H	86H	00H	
LREG8	Ramp Generator Enable, Level Meter Path Selection and Notch/Bandpass Filter Characteristic Configuration, UTD Source Selection and UTD Enable	RAMP_EN	Reserved	LM_NOTCH	LM_FILTER	LM_SRC	DC_SRC	UTD_SRC	UTD_EN	07H	87H	00H	
LREG9	level meter source and shift factor selection	K[3:0]				LM_SEL[3:0]				08H	88H	00H	
LREG10	level meter threshold, rectifier on/off, gain factor	OTHRE	LM_GF	LM_RECT	Reserved			LM_TH[2:0]		09H	89H	00H	
LREG11	Debounce filter	DB[3:0]				DB_IO[3:0]				0AH	8AH	00H	
LREG12	PCM data low byte	PCM[7:0]								0BH	-	00H	
LREG13	PCM data high byte	PCM[15:8]								0CH	-	00H	
LREG14	UTD RTIME	UTD_RT[7:0]								0DH	8DH	13H	
LREG15	UTD RBKTime	UTD_RBK[7:0]								0EH	8EH	19H	
LREG16	UTD ETIME	UTD_ET[7:0]								0FH	8FH	40H	
LREG17	UTD EBRKTime	UTD_EBRK[7:0]								10H	90H	64H	
LREG18	Interrupt mask	Reserved			GK_M	HK_M	OTMP_M	RAMP_M	GKP_M	11H	91H	1FH	
LREG19	IO interrupt mask, polarity reverse, external ringing sync enable	Reserved		REV_POL	SYNC_EN	IO_M[3:0]			12H	92H	0FH		
LREG20	IO pin direction select and IO data	IO_C[3:0]				IO[3:0]				13H	93H	00H	
LREG21	Interrupt source and DC feeding characteristic indication	FEED_I	FEED_V	FEED_R	LM_OK	UTD_OK	OTMP	RAMP_OK	GK_POL	14H	-	01H	

In the following global registers and local registers lists, it should be noted that:

1. $\bar{R}/W = 0$, Read command. $\bar{R}/W = 1$, Write command.
2. The reserved bit(s) in the register must be filled in '0' in write operation and will be ignored in read operation.
3. The global or local registers described below are available for both MPI and GCI modes except for those with special statement.

5.3.2 GLOBAL REGISTERS LIST

GREG1: PLL Power Down, Read/Write (20H/A0H)

	b7	b6	b5	b4	b3	b2	b1	b0
Command	\bar{R}/W	0	1	0	0	0	0	0
I/O data	PLL_PD	Reserved						

PLL_PD Power down the internal PLL block (refer to "6.2 PLL Power Down" on page 90 for details).
 PLL_PD = 0: the internal PLL block is powered up (default);
 PLL_PD = 1: the internal PLL block is powered down.

Other bits in this register are reserved for future use.

GREG2: Reserved.

This register is reserved for future use.

GREG3: PCM Configuration, Read/Write (22H/A2H)

	b7	b6	b5	b4	b3	b2	b1	b0
Command	\bar{R}/W	0	1	0	0	0	1	0
I/O data	L_CODE	A/ μ	DBL_CLK	TR_SLOPE[1:0]		PCM_OFT[2:0]		

L_CODE Voice data code (8-bit, A/ μ -law compressed code or 16-bit linear code) selection
 L_CODE = 0: compressed code is selected (default);
 L_CODE = 1: linear code is selected.

A/ μ Select the PCM law
 A/ μ = 0: μ -law is selected;
 A/ μ = 1: A-law is selected (default).

DBL_CLK Clock mode (single or double) selection. **This bit is used for MPI mode only.**
 DBL_CLK = 0: single clock is selected (default);
 DBL_CLK = 1: double clock is selected.

TR_SLOPE[1:0] Transmit and receive slope selection. **The TR_SLOPE[1:0] bits are used for MPI mode only.**
 TR_SLOPE[1:0]=00: transmits data on the rising edges of BCLK, receives data on the falling edges of BCLK (default);
 TR_SLOPE[1:0]=01: transmits data on the rising edges of BCLK, receives data on the rising edges of BCLK;
 TR_SLOPE[1:0]=10: transmits data on the falling edges of BCLK, receives data on the falling edges of BCLK;
 TR_SLOPE[1:0]=11: transmits data on the falling edges of BCLK, receives data on the rising edges of BCLK;
Note: Please refer to IDT82V1074 Application Note (AN-380) for details on the effective edge selection of the BCLK signal with great jitter.

PCM_OFT[2:0] PCM timing offset selection. The PCM transmit/receive time slot can be offset from FSC by 0 to 7 BCLK periods. **The PCM_OFT[2:0] bits are used for MPI mode only.**
 PCM_OFT[2:0]=000: offset from FSC by 0 BCLK period (default);
 PCM_OFT[2:0]=001: offset from FSC by 1 BCLK period;
 PCM_OFT[2:0]=010: offset from FSC by 2 BCLK periods;
 PCM_OFT[2:0]=011: offset from FSC by 3 BCLK periods;
 PCM_OFT[2:0]=100: offset from FSC by 4 BCLK periods;
 PCM_OFT[2:0]=101: offset from FSC by 5 BCLK periods;
 PCM_OFT[2:0]=110: offset from FSC by 6 BCLK periods;
 PCM_OFT[2:0]=111: offset from FSC by 7 BCLK periods.

GREG4: Master Clock Selection and Channel Program Enable, Read/Write (23H/A3H)

	b7	b6	b5	b4	b3	b2	b1	b0
Command	\bar{R}/W	0	1	0	0	0	1	1
I/O data	CH_EN[3:0]				MCLK_SEL[3:0]			

CH_EN[3:0] Channel programming enable. In MPI mode, the channel programming enable command is used to specify the channel(s) to which the subsequent local command or Coe-RAM command will be applied. The CH_EN[3:0] bits enable Channel 4 to Channel 1 for programming, respectively. **The CH_EN[3:0] bits are used for MPI mode only.**
 CH_EN[3] = 0: Disabled, Channel 4 can not receive Local Commands and Coe-RAM Commands (default);
 CH_EN[3] = 1: Enabled, Channel 4 can receive Local Commands and Coe-RAM Commands;

CH_EN[2] = 0: Disabled, Channel 3 can not receive Local Commands and Coe-RAM Commands (default);
 CH_EN[2] = 1: Enabled, Channel 3 can receive Local Commands and Coe-RAM Commands;

CH_EN[1] = 0: Disabled, Channel 2 can not receive Local Commands and Coe-RAM Commands (default);
 CH_EN[1] = 1: Enabled, Channel 2 can receive Local Commands and Coe-RAM Commands;

CH_EN[0] = 0: Disabled, Channel 1 can not receive Local Commands and Coe-RAM Commands (default);
 CH_EN[0] = 1: Enabled, Channel 1 can receive Local Commands and Coe-RAM Commands;

MCLK_SEL[3:0] Select the frequency of the master clock. In MPI mode, there are nine frequencies can be selected as the master clock. **The MCLK_SEL[3:0] bits are used for MPI mode only.**
 (In GCI mode, the frequency of the master clock is either 2.048 MHz or 4.096 MHz, the same as the frequency of Data Clock (DCL). The internal circuit of the CODEC monitors the DCL input to determine which frequency is being used.)

MCLK_SEL[3:0] = 0000: 8.192 MHz
 MCLK_SEL[3:0] = 0001: 4.096 MHz
 MCLK_SEL[3:0] = 0010: 2.048 MHz (default)
 MCLK_SEL[3:0] = 0110: 1.536 MHz
 MCLK_SEL[3:0] = 1110: 1.544 MHz
 MCLK_SEL[3:0] = 0101: 3.072 MHz
 MCLK_SEL[3:0] = 1101: 3.088 MHz
 MCLK_SEL[3:0] = 0100: 6.144 MHz
 MCLK_SEL[3:0] = 1100: 6.176 MHz

GREG5: Hardware and Software Reset, Write (A4H); Version Number, Read (24H)

	b7	b6	b5	b4	b3	b2	b1	b0
Command	\bar{R}/W	0	1	0	0	1	0	0
I/O data	HW_RST	Reserved	SW_RST	Reserved	RCH_SEL[3]	RCH_SEL[2]	RCH_SEL[1]	RCH_SEL[0]

When write this register, a hardware or a software reset will be applied as described below:

HW_RST Hardware reset of the CODEC. The action of this hardware reset is equivalent to pulling the $\overline{\text{RESET}}$ pin of the CODEC low.

HW_RST = 0: No hardware reset signal will be generated (default);
 HW_RST = 1: A hardware reset signal will be generated.

SW_RST Software reset of the CODEC. This software reset operation resets those local registers specified by the RCH_SEL[3:0] bits, but the Coe-RAM is not affected.

SW_RST = 0: No software reset signal will be generated (default);
 SW_RST = 1: A software reset signal will be generated. If the SW_RST bit is set to 1, those local registers specified by the RCH_SEL[3:0] bits will be reset, but other local registers and all the global registers as well as the Coe-RAM will not be affected.

RCH_SEL[3:0] Select channel(s) for software reset. The RCH_SEL[3:0] bits select the local registers of Channel 4 to Channel 1, respectively, to be reset.

RCH_SEL[3] = 0: The local registers of Channel 4 will not be reset after executing a software reset command (default);
 RCH_SEL[3] = 1: The local registers of Channel 4 will be reset after executing a software reset command;

RCH_SEL[2] = 0: The local registers of Channel 3 will not be reset after executing a software reset command (default);
 RCH_SEL[2] = 1: The local registers of Channel 3 will be reset after executing a software reset command;

RCH_SEL[1] = 0: The local registers of Channel 2 will not be reset after executing a software reset command (default);
 RCH_SEL[1] = 1: The local registers of Channel 2 will be reset after executing a software reset command;

RCH_SEL[0] = 0: The local registers of Channel 1 will not be reset after executing a software reset command (default);
 RCH_SEL[0] = 1: The local registers of Channel 1 will be reset after executing a software reset command;

When read this register, the CODEC version number of 5AH will be read out.

GREG6: Test Loopback Control, Read/Write (25H/A5H)

	b7	b6	b5	b4	b3	b2	b1	b0
Command	R/W	0	1	0	0	1	0	1
I/O data	Reserved	ALB_64K	ALB_8K	ALB_DI	Reserved	DLB_64K	DLB_8K	DLB_DI

This register is used to enable the analog and digital loopbacks for testing.

ALB_64K Analog loopback via 64 KHz

ALB_64K = 0: ALB_64K loopback is disabled (normal operation) (default);

ALB_64K = 1: ALB_64K loopback is enabled.

ALB_8K Analog loopback via 8 KHz

ALB_8K = 0: ALB_8K loopback is disabled (normal operation) (default);

ALB_8K = 1: ALB_8K loopback is enabled.

ALB_DI Analog loopback via DX to DR (**This loopback is available for MPI mode only**)

ALB_DI = 0: ALB_DI loopback is disabled (normal operation) (default);

ALB_DI = 1: ALB_DI loopback is enabled.

DLB_64K Digital loopback via 64 KHz

DLB_64K = 0: DLB_64K loopback is disabled (normal operation) (default);

DLB_64K = 1: DLB_64K loopback is enabled.

DLB_8K Digital loopback via 8 KHz

DLB_8K = 0: DLB_8K loopback is disabled (normal operation) (default);

DLB_8K = 1: DLB_8K loopback is enabled.

DLB_DI Digital loopback via DR to DX (**This loopback is available for MPI mode only**)

DLB_DI = 0: DLB_DI loopback is disabled (normal operation) (default);

DLB_DI = 1: DLB_DI loopback is enabled.

GREG7: Three-Party Conference Configuration, Read/Write (26H/A6H)

	b7	b6	b5	b4	b3	b2	b1	b0
Command	R/W	0	1	0	0	1	1	0
I/O data	Reserved				CONF_EN	CONFX_EN	CONF_CS[1:0]	

CONF_EN Enable internal three-party conference

CONF_EN = 0: Internal conference is disabled (default);

CONF_EN = 1: Internal conference is enabled.

CONFX_EN Enable external three-party conference

CONFX_EN = 0: External conference is disabled (default);

CONFX_EN = 1: External conference is enabled.

CONF_CS[1:0] Select a channel for three-party conference

CONF_CS[1:0] = 00: Channel 1 is selected (default);

CONF_CS[1:0] = 01: Channel 2 is selected;
 CONF_CS[1:0] = 10: Channel 3 is selected;
 CONF_CS[1:0] = 11: Channel 4 is selected.

GREG8: Three-Party Conference Gain Setting, Read/Write (27H/A7H)

	b7	b6	b5	b4	b3	b2	b1	b0
Command	\bar{R}/W	0	1	0	0	1	1	1
I/O data	G_CONF[7:0]							

G_CONF[7:0] Gain of three-party conference. The gain is calculated by the following formula:
 Gain = G_CONF[7:0] / 256
 The default value of G_CONF[7:0] bits is 0(d).

GREG9: Transmit Time Slot and Highway Selection for Part B in Three-Party Conference, Read/Write (28H/A8H)

	b7	b6	b5	b4	b3	b2	b1	b0
Command	\bar{R}/W	0	1	0	1	0	0	0
I/O data	THS_B	TT_B[6:0]						

THS_B Transmit PCM highway selection for part B in three-party conference
 THS_B = 0: transmit PCM highway one (DX1) is selected (default);
 THS_B = 1: transmit PCM highway two (DX2) is selected.

TT_B[6:0] Transmit time slot selection for part B in three-party conference.
 The valid value of the TT_B[6:0] bits is from 0(d) to 127(d), corresponding to Time Slot 0 to Time Slot 127.
 The default value of TT_B[6:0] is 0(d).

GREG10: Receive Time Slot and Highway Selection for Part B in Three Party Conference, Read/Write (29H/A9H)

	b7	b6	b5	b4	b3	b2	b1	b0
Command	\bar{R}/W	0	1	0	1	0	0	1
I/O data	RHS_B	RT_B[6:0]						

RHS_B Receive PCM highway selection for part B in three-party conference
 RHS_B = 0: receive PCM highway one (DR1) is selected (default);
 RHS_B = 1: receive PCM highway two (DR2) is selected.

RT_B[6:0] Receive PCM time slot selection for part B in three-party conference.
 The valid value of the RT_B[6:0] bits is from 0(d) to 127(d), corresponding to Time Slot 0 to Time Slot 127.
 The default value of RT_B[6:0] is 0(d).

GREG11: Transmit Time Slot and Highway Selection for Part C in Three-Party Conference, Read/Write (2AH/AAH)

	b7	b6	b5	b4	b3	b2	b1	b0
Command	\bar{R}/W	0	1	0	1	0	1	0
I/O data	THS_C	TT_C[6:0]						

THS_C Transmit PCM highway selection for part C in three-party conference
 THS_C = 0: transmit PCM highway one (DX1) is selected (default);
 THS_C = 1: transmit PCM highway two (DX2) is selected.

TT_C[6:0] Transmit time slot selection for part C in three-party conference.
 The valid value of the TT_C[6:0] bits is from 0(d) to 127(d), corresponding to Time Slot 0 to Time Slot 127.
 The default value of TT_C[6:0] is 0(d).

GREG12: Receive Time Slot and Highway Selection for Part C in Three-Party Conference, Read/Write (2BH/ABH)

	b7	b6	b5	b4	b3	b2	b1	b0
Command	\bar{R}/W	0	1	0	1	0	1	1
I/O data	RHS_C	RT_C[6:0]						

RHS_C Receive PCM highway selection for part C in three-party conference
RHS_C = 0: receive PCM highway one (DR1) is selected (default);
RHS_C = 1: receive PCM highway two (DR2) is selected.

RT_C[6:0] Receive time slot selection for part C in three-party conference.
The valid value of the RT_C[6:0] bits is from 0(d) to 127(d), corresponding to Time Slot 0 to Time Slot 127.
The default value of RT_C[6:0] is 0(d).

GREG13: Transmit Time Slot and Highway Selection for Part D in Three-Party Conference, Read/Write (2CH/ACH)

	b7	b6	b5	b4	b3	b2	b1	b0
Command	\bar{R}/W	0	1	0	1	1	0	0
I/O data	THS_D	TT_D[6:0]						

THS_D Transmit PCM highway selection for part D in three-party conference
THS_D = 0: transmit PCM highway one (DX1) is selected (default);
THS_D = 1: transmit PCM highway two (DX2) is selected.

TT_D[6:0] Transmit time slot selection for part D in three-party conference.
The valid value of the TT_D[6:0] bits is from 0(d) to 127(d), corresponding to Time Slot 0 to Time Slot 127.
The default value of TT_D[6:0] is 0(d).

GREG14: Receive Time Slot and Highway Selection for Part D in Three-Party Conference, Read/Write (2DH/ADH)

	b7	b6	b5	b4	b3	b2	b1	b0
Command	\bar{R}/W	0	1	0	1	1	0	1
I/O data	RHS_D	RT_D[6:0]						

RHS_D Receive PCM highway selection for part D in three-party conference
RHS_D = 0: receive PCM highway one (DR1) is selected (default);
RHS_D = 1: receive PCM highway two (DR2) is selected.

RT_D[6:0] Receive time slot selection for part D in three-party conference.
The valid value of the RT_D[6:0] bits is from 0(d) to 127(d), corresponding to Time Slot 0 to Time Slot 127.
The default value of RT_D[6:0] is 0(d).

GREG15: Level Meter Count_Number Low 8 bits, Read/Write (2EH/AEH)

	b7	b6	b5	b4	b3	b2	b1	b0
Command	\bar{R}/W	0	1	0	1	1	1	0
I/O data	LM_CN[7:0]							

The LM_CN[7:0] bits in this register together with the LM_CN[10:8] bits in GREG16 form an 11-bit counter register, which is used for the level meter to set the time period for PCM data sampling.

The maximum number of time cycles set by the LM_CN[10:0] bits is 7FFH, corresponding to 255.875 ms. The time period for sampling can be programmed from 0 ms to 255.875 ms in steps of 0.125 ms (8k). If the LM_CN[10:0] bits are set to be 000H (corresponding to 0 ms), the PCM data will be transmitted transparently to the level meter result registers without being sampled.

LM_CN[10:0] = 0 (d): The PCM data is transmitted to level meter result registers GREG17 and GREG18 directly (default);
LM_CN[10:0] = N (d): The PCM data is sampled for $N * 125 \mu s$ (N from 1 to 2047).

GREG16: Level Meter Count_Number High 3 bits; Level Meter On/Off, Channel Selection and Once/Continuous Measurement, Read/Write (2FH/AFH)

	b7	b6	b5	b4	b3	b2	b1	b0
Command	\bar{R}/W	0	1	0	1	1	1	1
I/O data	LM_ONCE	LM_EN	LM_CS	LM_CS[0]	Reserved	LM_CN[10:8]		

LM_ONCE Execution mode of the integrator in level meter. The integration can be executed continuously or once after every initiation.

LM_ONCE = 0: The integrator runs continuously (default);

LM_ONCE = 1: The integrator runs only once. To start again, the LM_EN bit must be set from 0 to 1 again.

LM_EN Level meter function enable. This bit starts or stops level metering.

LM_EN = 0: disabled, level metering stops (default);

LM_EN = 1: enabled, level metering starts.

LM_CS Level meter channel selection. The LM_CS[1:0] bits determine the data on which channel will be level metered.

LM_CS[1:0] = 00: The data on Channel 1 will be input to the level meter (default);

LM_CS[1:0] = 01: The data on Channel 2 will be input to the level meter;

LM_CS[1:0] = 10: The data on Channel 3 will be input to the level meter;

LM_CS[1:0] = 11: The data on Channel 4 will be input to the level meter.

LM_CN Level meter count number high 3 bits LM_CN[10:8]. Refer to the description of GREG15 for details.

GREG17: Level Meter Result Register (Low), Read Only (30H)

	b7	b6	b5	b4	b3	b2	b1	b0
Command	0	0	1	1	0	0	0	0
I/O data	LMRL[7:0]							

This register contains the low byte of the level meter result. The default value of LMRL[7:0] bits is 0.

GREG18: Level Meter Result Register (High), Read Only (31H)

	b7	b6	b5	b4	b3	b2	b1	b0
Command	0	0	1	1	0	0	0	1
I/O data	LMRH[7:0]							

This register contains the high byte of the level meter result. The default value of the LMRH[7:0] is 0.

GREG19: FSK Flag Length Register, Read/Write (32H/B2H)

	b7	b6	b5	b4	b3	b2	b1	b0
Command	\bar{R}/W	0	1	1	0	0	1	0
I/O data	FSK_FL[7:0]							

The flag signal is a stream of '1'. It is transmitted between two message bytes during the Caller ID data transmission.

This register is used to set the number of the flag bits '1'. The value of FSK_FL[7:0] bits is valid from 0 to 255(d).

The default value of 0(d) means that no flag signal will be sent out.

GREG20: FSK Data Length Register, Read/Write (33H/B3H)

	b7	b6	b5	b4	b3	b2	b1	b0
Command	\bar{R}/W	0	1	1	0	0	1	1
I/O data	FSK_DL[7:0]							

This register is used to set the length of the data bytes that will be transmitted except the flag signal.

The value of the FSK_DL[7:0] bits is valid from 0 to 64(d). Any value larger than 64(d) will be taken as 64(d) by the DSP.

The default value of 0 means that no data bytes will be sent out.

GREG21: FSK Seizure Length Register, Read/Write (34H/B4H)

	b7	b6	b5	b4	b3	b2	b1	b0
Command	\bar{R}/W	0	1	1	0	1	0	0
I/O data	FSK_SL[7:0]							

The seizure length is the number of '01' pairs that represent the seizure phase.

The seizure length is two times of the value of the FSK_SL[7:0] bits. The value of the FSK_SL[7:0] bits is valid from 0 to 255(d), corresponding to the seizure length from 0 to 510 (d).

The default value of this register is 0, that means no seizure signal will be sent out.

GREG22: FSK Mark Length Register, Read/Write (35H/B5H)

	b7	b6	b5	b4	b3	b2	b1	b0
Command	\bar{R}/W	0	1	1	0	1	0	1
I/O data	FSK_ML[7:0]							

The mark signal is a stream of '1' that will be transmitted in initial flag phase.

This register is used to set the number of the mark bits '1'. The value of the FSK_ML[7:0] bits is valid from 0 to 255(d).

The default value of 0 means that no mark signal will be sent out.

GREG23: FSK Transmit Start, Mark_after_send, Modulation Standard, FSK Channel Selection, FSK enable, Read/Write (36H/B6H)

	b7	b6	b5	b4	b3	b2	b1	b0
Command	\bar{R}/W	0	1	1	0	1	1	0
I/O data	Reserved		FSK_CS[1:0]		FSK_EN	FSK_BS	FSK_MAS	FSK_TS

FSK_CS FSK channel selection. The FSK_CS[1:0] bits select a channel on which the FSK signal is generated.

FSK_CS[1:0] = 00: Channel 1 is selected (default);

FSK_CS[1:0] = 01: Channel 2 is selected;

FSK_CS[1:0] = 10: Channel 3 is selected;

FSK_CS[1:0] = 11: Channel 4 is selected.

FSK_EN FSK function block enable.

FSK_EN = 0: FSK function block is disabled (default);

FSK_EN = 1: FSK function block is enabled.

FSK_BS FSK modulation standard selection

FSK_BS = 0: BELL 202 standard is selected (default);

FSK_BS = 1: ITU-T V.23 standard is selected.

FSK_MAS Mark After Send. The FSK_MAS bit determines whether the FSK generator will keep on sending a mark-after-send signal (a string of '1') after finish sending the data in the FSK-RAM.

FSK_MAS = 0: The FSK output will be muted after sending out the data in the FSK-RAM (default);

FSK_MAS = 1: The FSK generator sends out a mark-after-send signal after finish sending out the data in the FSK-RAM. This signal will be stopped if the FSK_MAS bit is set to 0.

FSK_TS FSK transmission starts.

FSK_TS = 0: FSK transmission is disabled (default);

FSK_TS = 1: FSK transmission starts.

The FSK_TS bit will be reset automatically after the data in the FSK-RAM is finished sending. If the seizure length, the mark length and the data length are set to 0, the FSK_TS bit will be reset to 0 immediately after it is set to 1.

GREG24: Interrupt Polarity Selection Register, Read/Write (37H/B7H)

	b7	b6	b5	b4	b3	b2	b1	b0
Command	\bar{R}/W	0	1	1	0	1	1	1
I/O data	Reserved			INT_POL	Reserved			

INT_POL Interrupt polarity selection. The INT_POL bit determines the valid polarity of all the interrupt signals including the INT_CHA and INT_CHB bits in GCI C/I channel.

INT_POL = 0: Active low (default);

INT_POL = 1: Active high.

GREG25: Reserved

This register is reserved for future use.

GREG26: RSLIC Status, Read (39H); Interrupt Clear, Write (B9H)

	b7	b6	b5	b4	b3	b2	b1	b0
Command	\bar{R}/W	0	1	1	1	0	0	1
I/O data	GK[3]	HK[3]	GK[2]	HK[2]	GK[1]	HK[1]	GK[0]	HK[0]

In MPI mode, when applying a read operation to this register, the off-hook and ground-key status of all four channels will be read out. If an interrupt caused by off-hook or ground-key detection is pending, reading this register will clear the interrupt.

HK[3:0] Off-hook status.

HK[0] = 0: Channel 1 is on-hook (default);

HK[0] = 1: Channel 1 is off-hook.

HK[1] = 0: Channel 2 is on-hook (default);

HK[1] = 1: Channel 2 is off-hook.

HK[2] = 0: Channel 3 is on-hook (default);

HK[2] = 1: Channel 3 is off-hook.

HK[3] = 0: Channel 4 is on-hook (default);

HK[3] = 1: Channel 4 is off-hook.

GK[3:0] ground-key status.

GK[0] = 0: No longitudinal current detected on Channel 1 (default);

GK[0] = 1: Longitudinal current detected (ground-key or ground start) on Channel 1;

GK[1] = 0: No longitudinal current detected on Channel 2 (default);

GK[1] = 1: Longitudinal current detected (ground-key or ground start) on Channel 2;

GK[2] = 0: No longitudinal current detected on Channel 3 (default);

GK[2] = 1: Longitudinal current detected (ground-key or ground start) on Channel 3;

GK[3] = 0: No longitudinal current detected on Channel 4 (default);

GK[3] = 1: Longitudinal current detected (ground-key or ground start) on Channel 4;

In GCI mode, the off-hook and ground-key status are reported via the upstream C/I channel only. Reading this register will always get a result of 00H. If an interrupt caused by off-hook or ground-key detection is pending, applying a read command to this register will clear the interrupt.

In both MPI and GCI modes, when applying a write operation to this register, all the interrupts will be cleared.

5.3.3 LOCAL REGISTERS LIST

LREG1: Transmit Time Slot and Transmit Highway Selection, Read/Write (00H/80H). This register is used for MPI mode only.

	b7	b6	b5	b4	b3	b2	b1	b0
Command	R/W	0	0	0	0	0	0	0
I/O data	THS	TT[6:0]						

THS Transmit PCM highway selection for the specified channel.
 THS = 0: transmit PCM highway one (DX1) is selected (default);
 THS = 1: transmit PCM highway two (DX2) is selected.

TT[6:0] Transmit time slot selection for the specified channel.
 The valid value of the TT[6:0] bits is from 0(d) to 127(d), corresponding to Time Slot 0 to Time Slot 127.
 The default value of TT[6:0] is 00H for Channel 1, 01H for Channel 2, 02H for Channel 3 and 03H for Channel 4.

LREG2: Receive Time Slot and Receive Highway Selection, Read/Write (01H/81H). This register is used for MPI mode only.

	b7	b6	b5	b4	b3	b2	b1	b0
Command	R/W	0	0	0	0	0	0	1
I/O data	RHS	RT[6:0]						

RHS Receive PCM highway selection for the specified channel.
 RHS = 0: receive PCM highway one (DR1) is selected (default);
 RHS = 1: receive PCM highway two (DR2) is selected.

RT[6:0] Receive time slot selection for the specified channel.
 The valid value of the RT[6:0] bits is from 0(d) to 127(d), corresponding to Time Slot 0 to Time Slot 127.
 The default value of RT[6:0] is 00H for Channel 1, 01H for Channel 2, 02H for Channel 3 and 03H for Channel 4.

LREG3: Loopback Control, Read/Write (02H/82H)

	b7	b6	b5	b4	b3	b2	b1	b0
Command	R/W	0	0	0	0	0	1	0
I/O data	Reserved	DLB_2M	DLB_PCM	Reserved	ALB_1MDC	ALB_2M	ALB_PCM	CUTOFF

The register is used to enable the digital and analog loopbacks on the specified channel(s) for testing.

DLB_2M Digital loopback via 2M
 DLB_2M = 0: disabled (normal operation) (default);
 DLB_2M = 1: enabled (closed);

DLB_PCM Digital loopback via the PCM interface (**This loopback is available for MPI mode only**)
 DLB_PCM = 0: disabled (normal operation) (default);
 DLB_PCM = 1: enabled (closed);

ALB_1MDC Analog loopback via 1M in the DC loop
 ALB_1MDC = 0: disabled (normal operation) (default);
 ALB_1MDC = 1: enabled (closed);

ALB_2M Analog loopback via 2M
 ALB_2M = 0: disabled (normal operation) (default);
 ALB_2M = 1: enabled (closed);

ALB_PCM Analog loopback via the PCM interface (**This loopback is available for MPI mode only**)
 ALB_PCM = 0: disabled (normal operation) (default);
 ALB_PCM = 1: enabled (closed);

CUTOFF Cut off PCM receive path

CUTOFF = 0: disabled, the PCM receive path is in normal operation (default);
 CUTOFF = 1: enabled, the PCM receive path is cut off.

LREG4: Coefficient Selection, Read/Write (03H/83H)

	b7	b6	b5	b4	b3	b2	b1	b0
Command	R/W	0	0	0	0	0	1	1
I/O data	FRR	GRX	FRX	GTX	TG	ECF	IMF	DC_OFT

This register determines whether the default values or the coefficients in Coe-RAM is selected for the programmable filters, tone generators and DC offset compensation.

FRR Coefficient selection for the Frequency Response correction in the Receive path

FRR = 0: coefficient in the Coe-RAM is selected;

FRR = 1: the frequency response correction in the receive path is disabled (default).

GRX Coefficient selection for the digital Gain filter in the Receive path

GRX = 0: coefficient in the Coe-RAM is selected;

GRX = 1: the digital gain in the receive path is 0 dB (default).

FRX Coefficient selection for the Frequency Response correction in the Transmit path

FRX = 0: coefficient in the Coe-RAM is selected;

FRX = 1: the frequency response correction in the transmit path is disabled (default).

GTX Coefficient selection for the digital Gain filter in the Transmit path

GTX = 0: coefficient in the Coe-RAM is selected;

GTX = 1: the digital gain in the transmit path is 0 dB (default).

TG Coefficient selection for the Tone Generators (TG1 and TG2)

TG = 0: coefficient in the Coe-RAM is selected;

TG = 1: coefficient in the ROM is selected (default)

(The default values are: TG1Amp = 0.94 V, TG1Freq = 852 Hz, TG2Amp = 0.94 V, TG2Freq = 1447 Hz).

ECF Coefficient selection for the Echo Cancellation filter

ECF = 0: coefficient in the Coe-RAM is selected;

ECF = 1: the echo cancellation filter is disabled (default).

IMF Coefficient selection for the Impedance Matching filter

IMF = 0: coefficient in the Coe-RAM is selected;

IMF = 1: the impedance matching filter is disabled (default).

DC_OFT Compensation value selection for the Offset Register

DC_OFT = 0: the compensation value in the Coe-RAM is used;

DC_OFT = 1: the DC offset compensation value in the ROM (which is 0) is used (default).

LREG5: Coefficient Selection and Filter Control Register, Read/Write (04H/84H)

	b7	b6	b5	b4	b3	b2	b1	b0
Command	R/W	0	0	0	0	1	0	0
I/O data	V90	HPF	LM_B	LM_N	UTD	Signaling	DC_FEED	RG

V90 V90 filter characteristic enable. The bit is used to select the filter characteristic of the lowpass filter in voice signal path. The V90 filter characteristic may be selected for a modem transmission to improve the transmission rate and performance.

V90 = 0: The V90 filter is enabled;

V90 = 1: The V90 filter is disabled (default);.

HPF Enable/disable the highpass filter

	HPF = 0:	The highpass filter is enabled (default);
	HPF = 1:	The highpass filter is disabled.
LM_B	Coefficient selection for the level meter bandpass filter	
	LM_B = 0:	coefficient in the Coe-RAM is used for the level meter bandpass filter;
	LM_B = 1:	coefficient in the ROM is used for the level meter bandpass filter (default).
LM_N	Coefficient selection for the level meter notch filter	
	LM_N = 0:	coefficient in the Coe-RAM is used for the level meter notch filter;
	LM_N = 1:	coefficient in the ROM is used for the level meter notch filter (default).
UTD	Coefficient and threshold selection for the UTD	
	UTD = 0:	coefficient and threshold in the Coe-RAM are used for UTD;
	UTD = 1:	coefficient and threshold in the ROM are used for UTD (default).
Signaling	Coefficient selection for signaling (thresholds for off-hook, ground-key and ring trip detection)	
	Signaling = 0:	coefficients in the Coe-RAM are used;
	Signaling = 1:	coefficients in the ROM are used (refer to Table - 23 on page 62 for details) (default).
DC_FEED	Coefficient selection for DC feeding characteristic	
	DC_FEED = 0:	coefficient in the Coe-RAM is used;
	DC_FEED = 1:	coefficient in the ROM is used (default).
RG	Coefficients selection for Ring Generator and Ramp Generator	
	RG = 0:	coefficient in the Coe-RAM is used;
	RG = 1:	coefficient in the ROM is used (default).

LREG6: CODEC and RSLIC Mode Control Register, Read/Write (05H/85H)

	b7	b6	b5	b4	b3	b2	b1	b0
Command	R/W	0	0	0	0	1	0	1
I/O data	P_DOWN	STANDBY	ACTIVE	RAMP	SCAN_EN	SM[2:0]		

All eight bits in this register and the RING bit in LREG7 are used to control the operating mode of the chipset. The higher four bits in this register and the RING bit in LREG7 are used to control the operating mode of the CODEC.

P_DOWN = 0: power down mode is disabled;
P_DOWN = 1: power down mode is enabled (default).

STANDBY = 0: standby mode is disabled (default);
STANDBY = 1: standby mode is enabled.

ACTIVE = 0: active mode is disabled (default);
ACTIVE = 1: active mode is enabled.

RAMP = 0: ramp mode is disabled (default);
RAMP = 1: ramp mode is enabled;

The lower four bits in this register are used to control the operating mode of the RSLIC. **These four bits are used for MPI mode only.** (In GCI mode, the SCAN_EN and SM[2:0] bits in the downstream C/I channel byte control the operating mode of the RSLIC. Refer to ["4.2.3.1 Downstream C/I Channel Byte"](#) on page 55 for details)

SCAN_EN = 0: the corresponding RSLIC will not be accessed (default);
SCAN_EN = 1: the corresponding RSLIC will be accessed.

The SM[2:0] bits determine the operating mode of the RSLIC as shown in the following:

SM[2:0] = '000': Normal Active mode (default);
SM[2:0] = '001': External Ring;
SM[2:0] = '010': Internal Ring;

SM[2:0] = '011': Ring Open;
 SM[2:0] = '100': Tip Open;
 SM[2:0] = '101': Internal Test;
 SM[2:0] = '110': Low Power Standby;
 SM[2:0] = '111': Power Down.

LREG7: Analog Gain Selection, AC/DC Ring Trip Selection, Ring Generator and Tone Generators Enable, Read/Write (06H/86H)

	b7	b6	b5	b4	b3	b2	b1	b0
Command	R/W	0	0	0	0	1	1	0
I/O data	Reserved		IM_629	RING	RT_SEL	RING_EN	TG2_EN	TG1_EN

IM_629 Analog Gain for Impedance Scaling (AGIS)
 IM_629 = 0: 600 Ω (only for loops with 600 Ω equivalent impedance) (default);
 IM_629 = 1: 900 Ω (for all loops including those with 600 Ω equivalent impedance).

RING CODEC operating mode control bit
 RING = 0: Ring mode is disabled (default);
 RING = 1: Ring mode is enabled.

RT_SEL AC/DC ring trip selection
 RT_SEL = 0: AC Ring Trip is selected (default);
 RT_SEL = 1: DC Ring Trip is selected.

RING_EN Enable the internal ring generator
 RING_EN = 0: internal ringing stops (default);
 RING_EN = 1: internal ringing starts.

TG2_EN Enable Tone Generator 2 (TG2)
 TG2_EN = 0: TG2 is disabled (default);
 TG2_EN = 1: TG2 is enabled.

TG1_EN Enable Tone Generator 1 (TG1)
 TG1_EN = 0: TG1 is disabled (default);
 TG1_EN = 1: TG1 is enabled.

LREG8: Ramp Generator Enable, Level Meter Path Selection and Notch/Bandpass Filter Characteristic Configuration, UTD Source Selection and UTD Enable, Read/Write (07H/87H)

	b7	b6	b5	b4	b3	b2	b1	b0
Command	R/W	0	0	0	0	1	1	1
I/O data	RAMP_EN	Reserved	LM_NOTCH	LM_FILT	LM_SRC	DC_SRC	UTD_SRC	UTD_EN

RAMP_EN Enable Ramp Generator
 RAMP_EN = 0: ramp generator is disabled (default);
 RAMP_EN = 1: ramp generator is enabled.

LM_NOTCH Level meter notch/bandpass filter characteristic selection
 LM_NOTCH = 0: notch filter characteristic is selected (default);
 LM_NOTCH = 1: bandpass filter characteristic is selected.

LM_FILT Level meter filter (bandpass/notch) enable
 LM_FILT = 0: level meter filter (bandpass/notch) is disabled (default);
 LM_FILT = 1: level meter filter (bandpass/notch) is enabled.

LM_SRC Level meter AC/DC source selection
 LM_SRC = 0: signal from DC path is selected for level metering (default);
 LM_SRC = 1: signal from AC path is selected for level metering.

DC_SRC	DC transmit/receive path selection for level meter DC_SRC = 0: signal from DC receive path is selected for level metering (default); DC_SRC = 1: signal from DC transmit path is selected for level metering.
UTD_SRC	UTD source selection UTD_SRC = 0: signal from receive path is detected by the UTD unit (default); UTD_SRC = 1: signal from transmit path is detected by the UTD unit.
UTD_EN	Enable the universal tone detection unit UTD_EN = 0: the UTD unit is disabled (default); UTD_EN = 1: the UTD unit is enabled.

LREG9: Level Meter Source and Shift Factor Selection, Read/Write (08H/88H)

	b7	b6	b5	b4	b3	b2	b1	b0
Command	\bar{R}/W	0	0	0	1	0	0	0
I/O data	K[3:0]				LM_SEL[3:0]			

K[3:0] Shift factor selection for the level meter.

K[3:0] = 0000:	KINT = 1 (default);
K[3:0] = 0001:	KINT = 1/2;
K[3:0] = 0010:	KINT = 1/4;
K[3:0] = 0011:	KINT = 1/8;
K[3:0] = 0100:	KINT = 1/16;
K[3:0] = 0101:	KINT = 1/32;
K[3:0] = 0110:	KINT = 1/64;
K[3:0] = 0111:	KINT = 1/128;
K[3:0] = 1000:	KINT = 1/256;
K[3:0] = 1001:	KINT = 1/512;
K[3:0] = 1010:	KINT = 1/1024;
K[3:0] = 1011 to 1111:	KINT = 1/2048;

LM_SEL[3:0]	Source selection for DC Level Meter LM_SEL[3:0] = 0000: DC voltage on VTDC is selected (default); LM_SEL[3:0] = 0100: DC out voltage on DCN-DCP is selected; LM_SEL[3:0] = 1001: DC voltage on VL is selected; LM_SEL[3:0] = 1010: Voltage on IO3 is selected; LM_SEL[3:0] = 1011: Voltage on IO4 is selected; LM_SEL[3:0] = 1100: Voltage on RTIN is selected; LM_SEL[3:0] = 1101: VDD/2 is selected; LM_SEL[3:0] = 1110: VCM (offset of encoding) is selected; LM_SEL[3:0] = 1111: Voltage on IO4-IO3 is selected;
-------------	---

LREG10: Level Meter Threshold, Rectifier On/Off, Gain Factor, Read/Write (09H/89H)

	b7	b6	b5	b4	b3	b2	b1	b0
Command	\bar{R}/W	0	0	0	1	0	0	1
I/O data	OTHRE	LM_GF	LM_RECT	Reserved		LM_TH[2:0]		

OTHRE	Over threshold indication for level meter. This bit is read only. OTHRE = 0: The level meter result is below the threshold (default); OTHRE = 1: The level meter result is over the threshold.
-------	--

LM_GF	Additional Gain Factor for level meter LM_GF = 0: No additional gain factor is selected (default); LM_GF = 1: Additional gain factor of 16 is selected.
-------	---

LM_RECT	Enable the rectifier in the level meter. LM_RECT = 0: The rectifier is disabled (default); LM_RECT = 1: The rectifier is enabled.
LM_TH[2:0]	Level meter threshold selection. If the absolute value of the level meter result exceeds the selected threshold, the OTHRE bit will be set to 1. LM_TH[2:0] = 000: Threshold is 0.0% (default); LM_TH[2:0] = 001: Threshold is 12.5%; LM_TH[2:0] = 010: Threshold is 25.0%; LM_TH[2:0] = 011: Threshold is 37.5%; LM_TH[2:0] = 100: Threshold is 50.0%; LM_TH[2:0] = 101: Threshold is 62.5%; LM_TH[2:0] = 110: Threshold is 75.0%; LM_TH[2:0] = 111: Threshold is 87.5%.

LREG11: Debounce Filter Configuration, Read/Write (0AH/8AH)

	b7	b6	b5	b4	b3	b2	b1	b0
Command	R/W	0	0	0	1	0	1	0
I/O data	DB[3:0]				DB_IO[3:0]			

DB[3:0] Debounce interval selection for off-hook and ground-key detection. The debounce interval is programmable from 0.125 ms to 2 ms in steps of 0.125 ms, corresponding to the minimal debounce time of from 2 ms to 30 ms.

DB[3:0] = 0000: the debounce interval is 0.125 ms, the minimal debounce time is 2 ms (default);
 DB[3:0] = 0001: the debounce interval is 0.250 ms, the minimal debounce time is 4 ms;
 DB[3:0] = 0010: the debounce interval is 0.375 ms, the minimal debounce time is 6 ms;

 DB[3:0] = 1110: the debounce interval is 1.875 ms, the minimal debounce time is 30 ms;
 DB[3:0] = 1111: the debounce interval is 2 ms, the minimal debounce time is 32 ms.

(Note: During operating mode switching, there might be a narrow pulse of about 15 ms occurring on VTDC, resulting in a false interrupt to be generated. If this happens, please set DB[3:0] to 0111B or above to filter this noise pulse.)

DB_IO[3:0] IO Pins debounce time selection (only effective for those IO pins used as digital inputs). The IO pins debounce time is programmable from 2.5 ms to 32.5 ms in steps of 2 ms.

DB_IO[3:0] = 0000: the minimal debounce time is 2.5 ms (default);
 DB_IO[3:0] = 0001: the minimal debounce time is 4.5 ms;
 DB_IO[3:0] = 0010: the minimal debounce time is 6.5 ms;

 DB_IO[3:0] = 1110: the minimal debounce time is 30.5 ms;
 DB_IO[3:0] = 1111: the minimal debounce time is 32.5 ms.

LREG12: PCM Data Low Byte Register, Read Only (0BH). This register is used for MPI mode only.

	b7	b6	b5	b4	b3	b2	b1	b0
Command	0	0	0	0	1	0	1	1
I/O data	PCM[7:0]							

This register is used for the master processor to monitor the transmit (A to D) PCM data. For linear code, the low byte of PCM data is sent to this register before it is transmitted to the PCM Encoder in the transmit path. For compressed code, the total PCM data is sent to this register before it is transmitted to the PCM Encoder in the transmit path.

LREG13: PCM Data High Byte Register, Read Only (0CH). This register is used for MPI mode only.

	b7	b6	b5	b4	b3	b2	b1	b0
Command	0	0	0	0	1	1	0	0
I/O data	PCM[15:8]							

This register is used for the master processor to monitor the transmit (A to D) PCM data. For linear code, the high byte of PCM data is sent to this register before it is transmitted to the PCM Encoder in the transmit path. For compressed code, this register is not used (in this case, when read, a data byte of 00H will be read out).

LREG14: UTD RTIME Register, Read/Write (0DH/8DH)

	b7	b6	b5	b4	b3	b2	b1	b0
Command	\bar{R}/W	0	0	0	1	1	0	1
I/O data	UTD_RT[7:0]							

This register is used to set the UTD Recognition Time (RTIME):

$$UTD_RT[7:0] = RTIME (ms)/16$$

The default value of UTD_RT[7:0] is 13H.

RTIME must be multiples of 16 ms. The range of it is: $0 \text{ ms} \leq RTIME \leq 4000 \text{ ms}$.

LREG15: UTD RBKTime Register, Read/Write (0EH/8EH)

	b7	b6	b5	b4	b3	b2	b1	b0
Command	\bar{R}/W	0	0	0	1	1	1	0
I/O data	UTD_RBK[7:0]							

This register is used to set the UTD Recognition Break Time (RBKTime):

$$UTD_RBK[7:0] = RBKTime (ms)/4$$

The default value of UTD_RBK[7:0] is 19H.

RBKTime must be multiples of 4 ms. The range of it is: $0 \text{ ms} \leq RBKTime \leq 1000 \text{ ms}$.

LREG16: UTD ETIME Register, Read/Write (0FH/8FH)

	b7	b6	b5	b4	b3	b2	b1	b0
Command	\bar{R}/W	0	0	0	1	1	1	1
I/O data	UTD_ET[7:0]							

This register is used to set the UTD End Detection Time (ETIME):

$$UTD_ET[7:0] = ETIME (ms)/4$$

The default value of UTD_ET[7:0] is 40H.

ETIME must be multiples of 4 ms. The range of it is: $0 \text{ ms} \leq ETIME \leq 1000 \text{ ms}$.

LREG17: UTD EBRKTime, Read/Write (10H/90H)

	b7	b6	b5	b4	b3	b2	b1	b0
Command	\bar{R}/W	0	0	1	0	0	0	0
I/O data	UTD_EBRK[7:0]							

This register is used to set the UTD End Detection Break Time (EBRKTime):

$$UTD_EBRK[7:0] = EBRKTime (ms)$$

The default value of UTD_EBRK[7:0] is 64H.

The range of the EBRKTime is: $0 \text{ ms} \leq EBRKTime \leq 255 \text{ ms}$.

LREG18: Interrupt Mask Register, Read/Write (11H/91H)

	b7	b6	b5	b4	b3	b2	b1	b0
Command	R/W	0	0	1	0	0	0	1
I/O data	Reserved			GK_M	HK_M	OTMP_M	RAMP_M	GKP_M

GK_M Mask bit for the ground-key status bits GK[3:0] in GREG26
 GK_M = 0: Each change of the GK[3:0] bits generates an interrupt;
 GK_M = 1: Changes of the GK[3:0] bits do not generate interrupts (default).

HK_M Mask bit for the off-hook status bits HK[3:0] in GREG26
 HK_M = 0: Each change of the HK[3:0] bits generates an interrupt;
 HK_M = 1: Changes of the HK[3:0] bits do not generate interrupts (default).

OTMP_M Mask bit for the over temperature status bit OTMP in LREG21
 OTMP_M = 0: Changes of the OTMP bit from 0 to 1 generate interrupts;
 OTMP_M = 1: Changes of the OTMP bit from 0 to 1 do not generate interrupts (default).

RAMP_M Mask bit for the RAMP_OK bit in LREG21
 RAMP_M = 0: Changes of the RAMP_OK bit from 0 to 1 generate interrupts;
 RAMP_M = 1: Changes of the RAMP_OK bit from 0 to 1 do not generate interrupt (default).

GKP_M Mask bit for the GK_POL bit in LREG21
 GKP_M = 0: Each change of the GK_POL bit generates an interrupt;
 GKP_M = 1: Changes of the GK_POL bit do not generate interrupts (default).

LREG19: IO Interrupt Mask Register, Read/Write (12H/92H)

	b7	b6	b5	b4	b3	b2	b1	b0
Command	R/W	0	0	1	0	0	1	0
I/O data	Reserved		REV_POL	SYNC_EN	IO_M[3]	IO_M[2]	IO_M[1]	IO_M[0]

REV_POL Reverse the polarity of DC feeding
 REV_POL = 0: Normal polarity (default);
 REV_POL = 1: Reverse polarity.

SYNC_EN Enable synchronous ringing for external ringing mode.
 SYNC_EN = 0: Asynchronous external ringing is selected (default);
 SYNC_EN = 1: External ringing with zero-crossing is selected;

IO_M[3:0] Mask bits for the IO status bits IO[3:0] in register LREG19 when the IO pins are configured as inputs.
 IO_M[3] = 0: Each change of the IO[3] bit generates an interrupt;
 IO_M[3] = 1: Changes of the IO[3] bit do not generate interrupts (default).

IO_M[2] = 0: Each change of the IO[2] bit generates an interrupt;
 IO_M[2] = 1: Changes of the IO[2] bit do not generate interrupts (default).

IO_M[1] = 0: Each change of the IO[1] bit generates an interrupt;
 IO_M[1] = 1: Changes of the IO[1] bit do not generate interrupts (default).

IO_M[0] = 0: Each change of the IO[0] bit generates an interrupt;
 IO_M[0] = 1: Changes of the IO[0] bit do not generate interrupts (default).

LREG20: RSLIC IO Direction Configuration and IO Status Register, Read/Write (13H/93H)

	b7	b6	b5	b4	b3	b2	b1	b0
Command	\bar{R}/W	0	0	1	0	0	1	1
I/O data	IO_C[3]	IO_C[2]	IO_C[1]	IO_C[0]	IO[3]	IO[2]	IO[1]	IO[0]

IO_C[3:0]	RSLIC IO direction configuration. The IO_C[3:0] bits determine the directions of the IO4 to IO1 pins, respectively. IO_C[3] = 0: The IO4 pin of the specified channel is configured as an input (default); IO_C[3] = 1: The IO4 pin of the specified channel is configured as an output. IO_C[2] = 0: The IO3 pin of the specified channel is configured as an input (default); IO_C[2] = 1: The IO3 pin of the specified channel is configured as an output. IO_C[1] = 0: The IO2 pin of the specified channel is configured as an input (default); IO_C[1] = 1: The IO2 pin of the specified channel is configured as an output. IO_C[0] = 0: The IO1 pin of the specified channel is configured as an input (default); IO_C[0] = 1: The IO1 pin of the specified channel is configured as an output.
IO[3:0]	IO pin status (when the corresponding IO pin is configured as an input) or IO control data (when the corresponding IO pin is configured as an output) IO[3] = 0: The IO4 pin of the specified channel is in logic low state (when configured as an input) or it is set to logic low (when configured as an output); IO[3] = 1: The IO4 pin of the specified channel is in logic high state (when configured as an input) or it is set to logic high (when configured as an output); IO[2] = 0: The IO3 pin of the specified channel is in logic low state (when configured as an input) or it is set to logic low (when configured as an output); IO[2] = 1: The IO3 pin of the specified channel is in logic high state (when configured as an input) or it is set to logic high (when configured as an output); IO[1] = 0: The IO2 pin of the specified channel is in logic low state (when configured as an input) or it is set to logic low (when configured as an output); IO[1] = 1: The IO2 pin of the specified channel is in logic high state (when configured as an input) or it is set to logic high (when configured as an output); IO[0] = 0: The IO1 pin of the specified channel is in logic low state (when configured as an input) or it is set to logic low (when configured as an output); IO[0] = 1: The IO1 pin of the specified channel is in logic high state (when configured as an input) or it is set to logic high (when configured as an output);

Once the IO_n pin is configured as an input, each change of the corresponding IO_n bit will generate an interrupt if the mask bit IO_M_n in LREG19 is set to 0. A read command to this register will clear the interrupt caused by changes of the IO[3:0] bits.

LREG21: Interrupt Source Register, Read Only (14H)

	b7	b6	b5	b4	b3	b2	b1	b0
Command	0	0	0	1	0	1	0	0
I/O data	FEED_I	FEED_V	FEED_R	LM_OK	UTD_OK	OTMP	RAMP_OK	GK_POL

FEED_I	DC feeding characteristic indication bit for the constant current zone. Whenever the DC feeding is operated at the constant zone, the FEED_I is set to 1, otherwise it is set to 0.
FEED_V	DC feeding characteristic indication bit for the constant voltage zone. Whenever the DC feeding is operated at the constant voltage zone, the FEED_V bit is set to 1, otherwise it is set to 0.
FEED_R	DC feeding characteristic indication bit for the resistive zone. Whenever the DC feeding is operated at the resistive zone, the FEED_R bit is set to 1, otherwise it is set to 0.

LM_OK	Indicating whether the level metering is finished. Changes of this bit from 0 to 1 generate interrupts (the LM_OK bit has no mask bit). LM_OK = 0: Level meter result is not ready (default); LM_OK = 1: Level meter result is ready.
UTD_OK	UTD result indication. Changes of this bit from 0 to 1 generate interrupts (the UTD_OK bit has no mask bit). UTD_OK = 0: No special tone signal (e.g., fax/modem) is detected (default); UTD_OK = 1: Special tone signal (e.g., fax/modem) is detected
OTMP	Over temperature detection result. Changes of this bit from 0 to 1 generate interrupts if the mask bit OTMP_M in register LREG18 is set to 0. OTMP = 0: Temperature at the RSLIC is below the limit (default); OTMP = 1: Temperature at the RSLIC is above the limit;
RAMP_OK	Indicating whether ramp generation is completed. Changes of this bit from 0 to 1 generate interrupts if the mask bit RAMP_M in register LREG18 is set to 0. When the ramp generator starts a new generation, the RAMP_OK bit will be reset to 0. RAMP_OK = 0: Ramp generation is not completed (default); RAMP_OK = 1: Ramp generation is completed;
GK_POL	ground-key polarity, indicating the active ground-key threshold (positive or negative). Changes of this bit generate interrupts if the mask bit GKP_M in register LREG18 is set to 0. GK_POL = 0: Negative ground-key threshold is active; GK_POL = 1: Positive ground-key threshold is active (default);

Applying a read command to this register will clear the interrupt caused by the valid change of the LM_OK, UTD_OK, OTMP, RAMP_OK or GK_POL bit.

5.4 PROGRAMMING EXAMPLES

5.4.1 PROGRAMMING EXAMPLES FOR MPI MODE

5.4.1.1 Example of Programming the Local Registers via MPI

• **Writing to LREG2 and LREG1 of Channel 1:**

- 1010,0011 Channel Enable command
- 0001,0010 Data for GREG4 (Channel 1 is enabled for programming)
- 1000,0001 Local register write command (The address is '00001', means that data will be written to LREG2 and LREG1.)
- 0000,0001 Data for LREG2
- 0000,0000 Data for LREG1

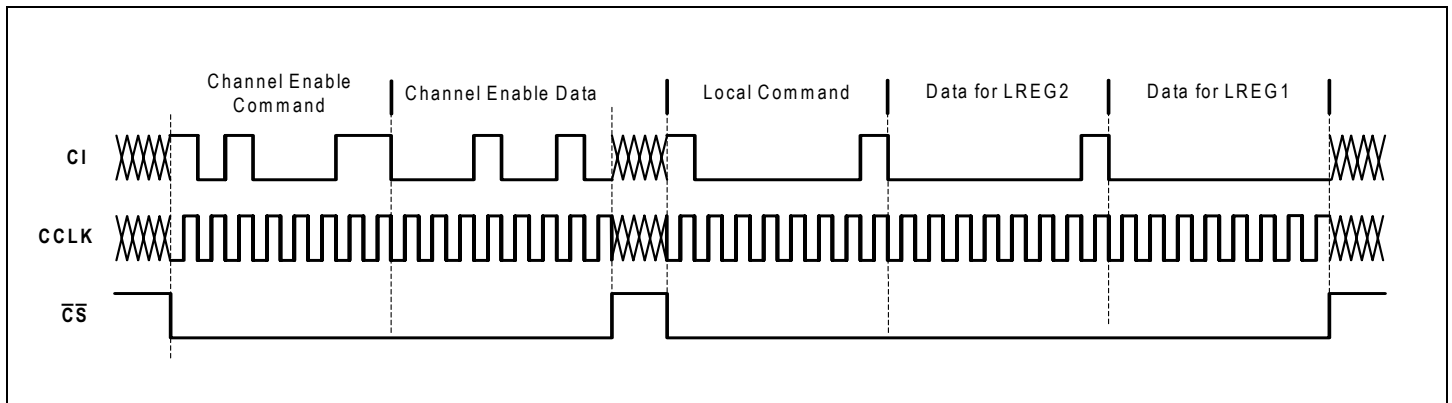

Figure - 36 Waveform of Programming Example: Writing to Local Registers

• **Reading LREG2 and LREG1 of Channel 1:**

- 1010,0011 Channel Enable command
- 0001,0010 Data for GREG4 (Channel 1 is enabled for programming)
- 0000,0001 Local register read command (The address is '00001', means that LREG2 and LREG1 will be read.)

After the preceding commands are executed, data will be sent out as follows:

- 1000,0001 Identification code
- 0000,0001 Data read out from LREG2
- 0000,0000 Data read out from LREG1

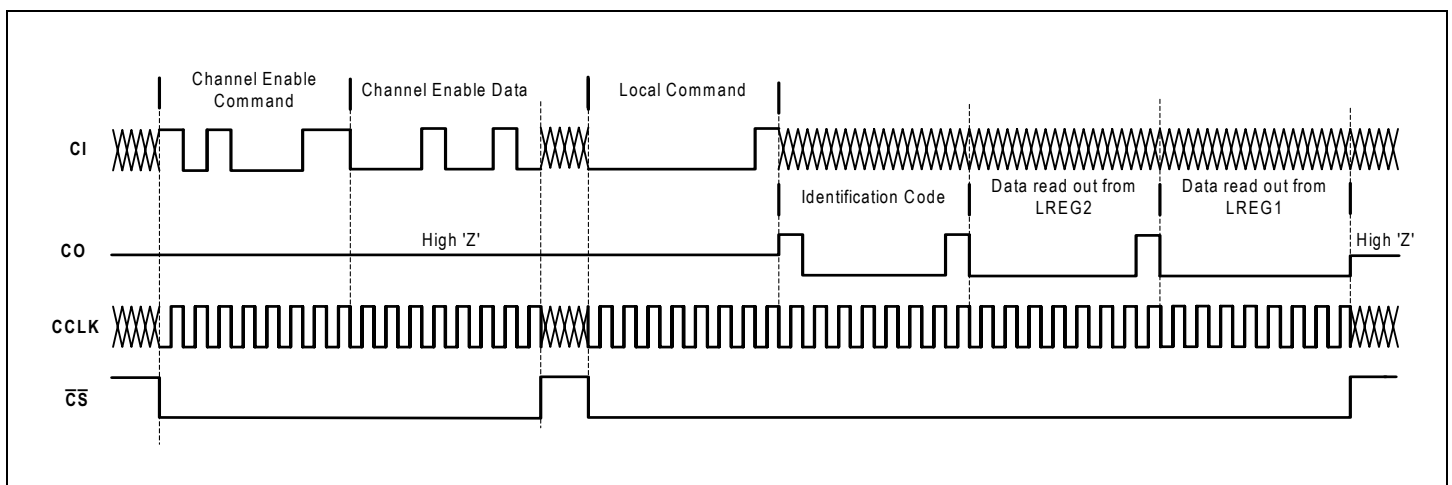

Figure - 37 Waveform of Programming Example: Reading Local Registers

5.4.1.2 Example of Programming the Global Registers via MPI

Since the global registers are shared by all four channels, it is no need to specify the channel(s) before addressing global registers. Except for this, programming global registers are the same as programming local registers. Refer to "5.4.1.1 Example of Programming the Local Registers via MPI" on page 83 for more information.

5.4.1.3 Example of Programming the Coefficient-RAM via MPI

- **Writing to the Coe-RAM of Channel 1:**

1010,0011	Channel Enable command
0001,0010	Data for GREG4 (Channel 1 is enabled for programming)
1110,0000	Coe-RAM write command (The address of '00000' is located in block 1, means that data will be written to block 1.)
byte 1	data for high byte of word 8 in block 1 (the highest two bits (b7b6) are ignored)
byte 2	data for low byte of word 8 in block 1
byte 3	data for high byte of word 7 in block 1 (the highest two bits (b7b6) are ignored)
byte 4	data for low byte of word 7 in block 1
byte 5	data for high byte of word 6 in block 1 (the highest two bits (b7b6) are ignored)
byte 6	data for low byte of word 6 in block 1
byte 7	data for high byte of word 5 in block 1 (the highest two bits (b7b6) are ignored)
byte 8	data for low byte of word 5 in block 1
byte 9	data for high byte of word 4 in block 1 (the highest two bits (b7b6) are ignored)
byte 10	data for low byte of word 4 in block 1
byte 11	data for high byte of word 3 in block 1 (the highest two bits (b7b6) are ignored)
byte 12	data for low byte of word 3 in block 1
byte 13	data for high byte of word 2 in block 1 (the highest two bits (b7b6) are ignored)
byte 14	data for low byte of word 2 in block 1
byte 15	data for high byte of word 1 in block 1 (the highest two bits (b7b6) are ignored)
byte 16	data for low byte of word 1 in block 1

- **Reading from the Coe-RAM of Channel 1:**

1010,0011	Channel Enable command
0001,0010	Data for GREG4 (Channel 1 is enabled for programming)
0110,0000	Coe-RAM read command (The address of '00000' is located in block 1, means that block 1 will be read.)

After the preceding commands are executed, data will be sent out as follows:

1000,0001	Identification code
byte 1	data read out from high byte of word 8 in block 1 (the highest two bits (b7b6) are meaningless)
byte 2	data read out from low byte of word 8 in block 1
byte 3	data read out from high byte of word 7 in block 1 (the highest two bits (b7b6) are meaningless)
byte 4	data read out from low byte of word 7 in block 1
byte 5	data read out from high byte of word 6 in block 1 (the highest two bits (b7b6) are meaningless)
byte 6	data read out from low byte of word 6 in block 1
byte 7	data read out from high byte of word 5 in block 1 (the highest two bits (b7b6) are meaningless)
byte 8	data read out from low byte of word 5 in block 1
byte 9	data read out from high byte of word 4 in block 1 (the highest two bits (b7b6) are meaningless)
byte 10	data read out from low byte of word 4 in block 1
byte 11	data read out from high byte of word 3 in block 1 (the highest two bits (b7b6) are meaningless)
byte 12	data read out from low byte of word 3 in block 1
byte 13	data read out from high byte of word 2 in block 1 (the highest two bits (b7b6) are meaningless)
byte 14	data read out from low byte of word 2 in block 1
byte 15	data read out from high byte of word 1 in block 1 (the highest two bits (b7b6) are meaningless)
byte 16	data read out from low byte of word 1 in block 1

5.4.1.4 Example of Programming the FSK-RAM via MPI

- **Writing to the FSK-RAM:**

1100,0001	FSK-RAM write command (The address is '00001', means that data will be written to word 2 and word 1.)
byte 1	data for high byte of word 2
byte 2	data for low byte of word 2
byte 3	data for high byte of word 1
byte 4	data for low byte of word 1

- **Reading from the FSK-RAM:**

0100,0001 FSK-RAM read command (The address is '00001', means that word 2 and word 1 will be read.)

After this command is executed, data will be sent out as follows:

1000,0001 Identification code
 byte 1 data read out from high byte of word 2
 byte 2 data read out from low byte of word 2
 byte 3 data read out from high byte of word 1
 byte 4 data read out from low byte of word 1

5.4.2 PROGRAMMING EXAMPLES FOR GCI MODE

5.4.2.1 Example of Programming the Local Registers via GCI

- **Writing to LREG2 and LREG1 of Channel 1:**

1000,0001 Program start command (provided channel A is the destination)
 1000,0001 Local register write command (The address is '00001', means that data will be written to LREG2 and LREG1.)
 0000,0001 data for LREG2
 0000,0000 data for LREG1

- **Reading from LREG2 and LREG1 of Channel 1:**

1000,0001 Program start command (provided channel A is the source)
 0000,0001 Local register read command (The address is '00001', means that LREG2 and LREG1 will be read.)
 After the preceding commands are executed, data will be read out as follows:
 1000,0001 Program start byte
 0000,0001 data read out from LREG2
 0000,0000 data read out from LREG1

5.4.2.2 Example of Programming the Global Registers via GCI

In GCI mode, the global registers are addressed in the similar manner as the local registers except the \bar{A}/B bit in the Program Start byte is neglected. See the descriptions above for details.

5.4.2.3 Example of Programming the Coefficient-RAM via GCI

- **Writing to the Coe-RAM of Channel 1:**

1000,0001 Program Start command (provided channel A is the destination)
 1110,0000 Coe-RAM write command (The address is '00001', means that data will be written to block 1.)
 byte 1 data for high byte of word 8 in block 1 (the highest two bits (b7b6) are ignored)
 byte 2 data for low byte of word 8 in block 1
 byte 3 data for high byte of word 7 in block 1 (the highest two bits (b7b6) are ignored)
 byte 4 data for low byte of word 7 in block 1
 byte 5 data for high byte of word 6 in block 1 (the highest two bits (b7b6) are ignored)
 byte 6 data for low byte of word 6 in block 1
 byte 7 data for high byte of word 5 in block 1 (the highest two bits (b7b6) are ignored)
 byte 8 data for low byte of word 5 in block 1
 byte 9 data for high byte of word 4 in block 1 (the highest two bits (b7b6) are ignored)
 byte 10 data for low byte of word 4 in block 1
 byte 11 data for high byte of word 3 in block 1 (the highest two bits (b7b6) are ignored)
 byte 12 data for low byte of word 3 in block 1
 byte 13 data for high byte of word 2 in block 1 (the highest two bits (b7b6) are ignored)
 byte 14 data for low byte of word 2 in block 1
 byte 15 data for high byte of word 1 in block 1 (the highest two bits (b7b6) are ignored)
 byte 16 data for low byte of word 1 in block 1

- **Reading from the Coe-RAM of Channel 1:**

1000,0001 Program Start command (provided channel A is the source)
 0110,0000 Coe-RAM read command (The address is '00000', means that block 1 will be read.)
 After these commands are executed, data will be sent out as follows:
 1000,0001 Program start byte
 byte 1 data read out from high byte of word 8 in block 1 (the highest two bits (b7b6) are meaningless)

byte 2	data read out from low byte of word 8 in block 1
byte 3	data read out from high byte of word 7 in block 1 (the highest two bits (b7b6) are meaningless)
byte 4	data read out from low byte of word 7 in block 1
byte 5	data read out from high byte of word 6 in block 1 (the highest two bits (b7b6) are meaningless)
byte 6	data read out from low byte of word 6 in block 1
byte 7	data read out from high byte of word 5 in block 1 (the highest two bits (b7b6) are meaningless)
byte 8	data read out from low byte of word 5 in block 1
byte 9	data read out from high byte of word 4 in block 1 (the highest two bits (b7b6) are meaningless)
byte 10	data read out from low byte of word 4 in block 1
byte 11	data read out from high byte of word 3 in block 1 (the highest two bits (b7b6) are meaningless)
byte 12	data read out from low byte of word 3 in block 1
byte 13	data read out from high byte of word 2 in block 1 (the highest two bits (b7b6) are meaningless)
byte 14	data read out from low byte of word 2 in block 1
byte 15	data read out from high byte of word 1 in block 1 (the highest two bits (b7b6) are meaningless)
byte 16	data read out from low byte of word 1 in block 1

5.4.2.4 Example of Programming the FSK-RAM via GCI

- **Writing to the FSK-RAM:**

100X,0001	Program Start command
1100,0001	FSK-RAM write command (The address is '00001', means that data will be written to word 2 and word 1.)
byte 1	data for high byte of word 2
byte 2	data for low byte of word 2
byte 3	data for high byte of word 1
byte 4	data for low byte of word 1

- **Reading from the FSK-RAM:**

100X,0001	Program Start command
0100,0001	FSK-RAM read command (The address is '00001', means that word 2 and word 1 will be read.)

After the preceding commands are executed, data will be sent out as follows:

100X,0001	Program Start byte
byte 1	data read out from high byte of word 2
byte 2	data read out from low byte of word 2
byte 3	data read out from high byte of word 1
byte 4	data read out from low byte of word 1

6 OPERATIONAL DESCRIPTION

6.1 OPERATING MODES

In many applications, the system power consumption is an important parameter. For large and remotely fed systems, this parameter is more critical and must be limited to a given value to meet cooling requirements and save power.

Generally, the system power dissipation is determined mainly by the high-voltage part. The most effective power-saving method is to limit SLIC functionality and reduce supply voltage in line according to different requirements. The RSLIC-CODEC chipset achieves this goal by providing different operating modes according to different loop states or testing requirements. See the following descriptions for details.

6.1.1 RSLIC CONTROL SIGNALING

The CODEC provides three common mode selection pins M1 to M3 and four individual chip selection pins CS1 to CS4 for the four RSLICs to control their operating modes. See [Figure - 38](#) for details.

The CS1 to CS4 pins of the CODEC are ternary logic pins as illustrated in the following:

- CSn = 0: The CODEC will send mode control data to the RSLICn through the M1 to M3 pins.
- CSn = 1: The CODEC will receive the temperature information of the RSLICn through the M3 pin.
- CSn = 1.5 V: The CODEC will not send or receive data to/from the RSLICn through the M1 to M3 pins.

Note that the M3 pin of the CODEC is bidirectional. Its direction is determined by the active CSn as described above. [Figure - 39](#) shows the RSLIC control timing diagram.

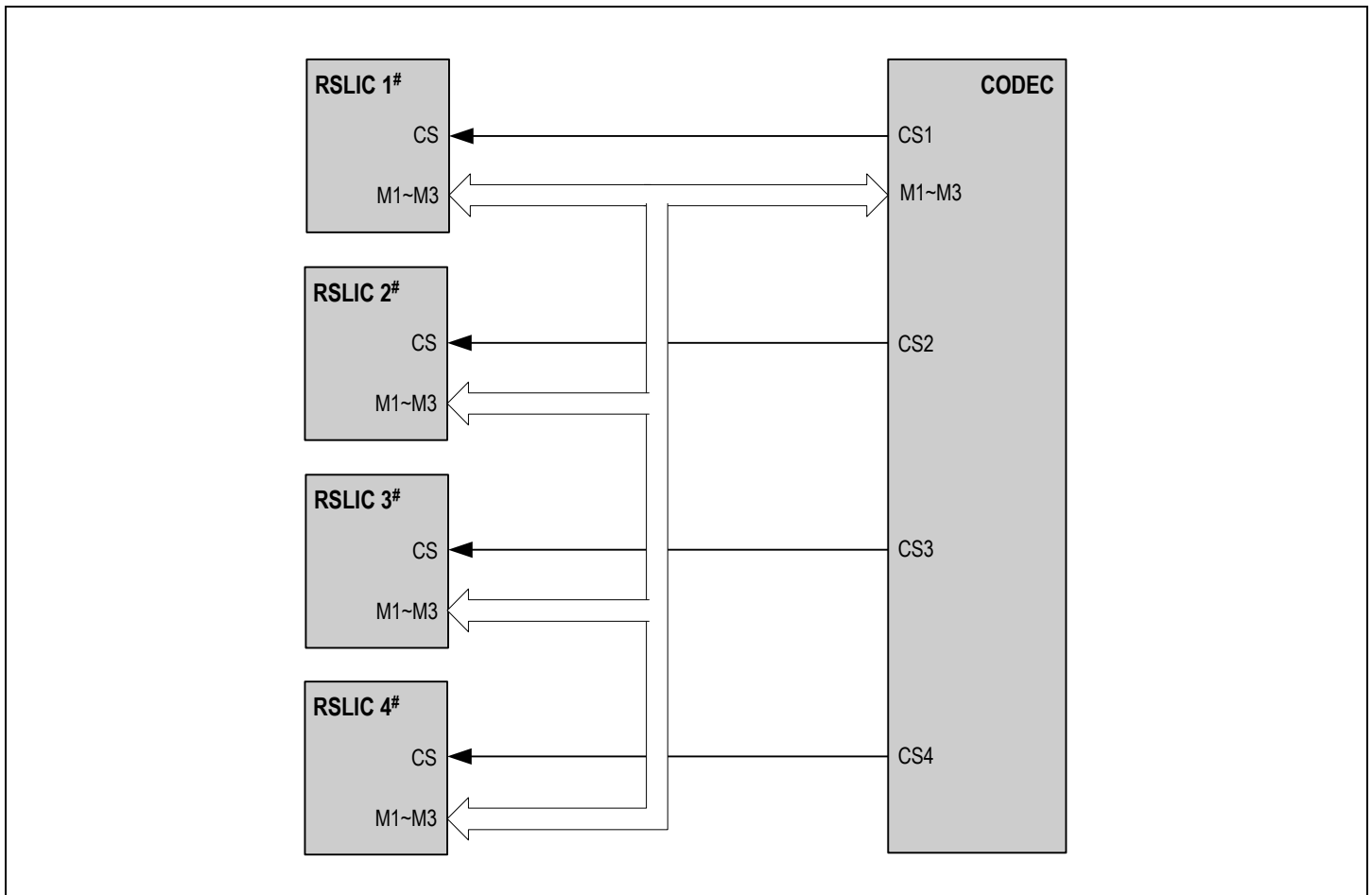

Figure - 38 RSLIC Mode Control Signaling

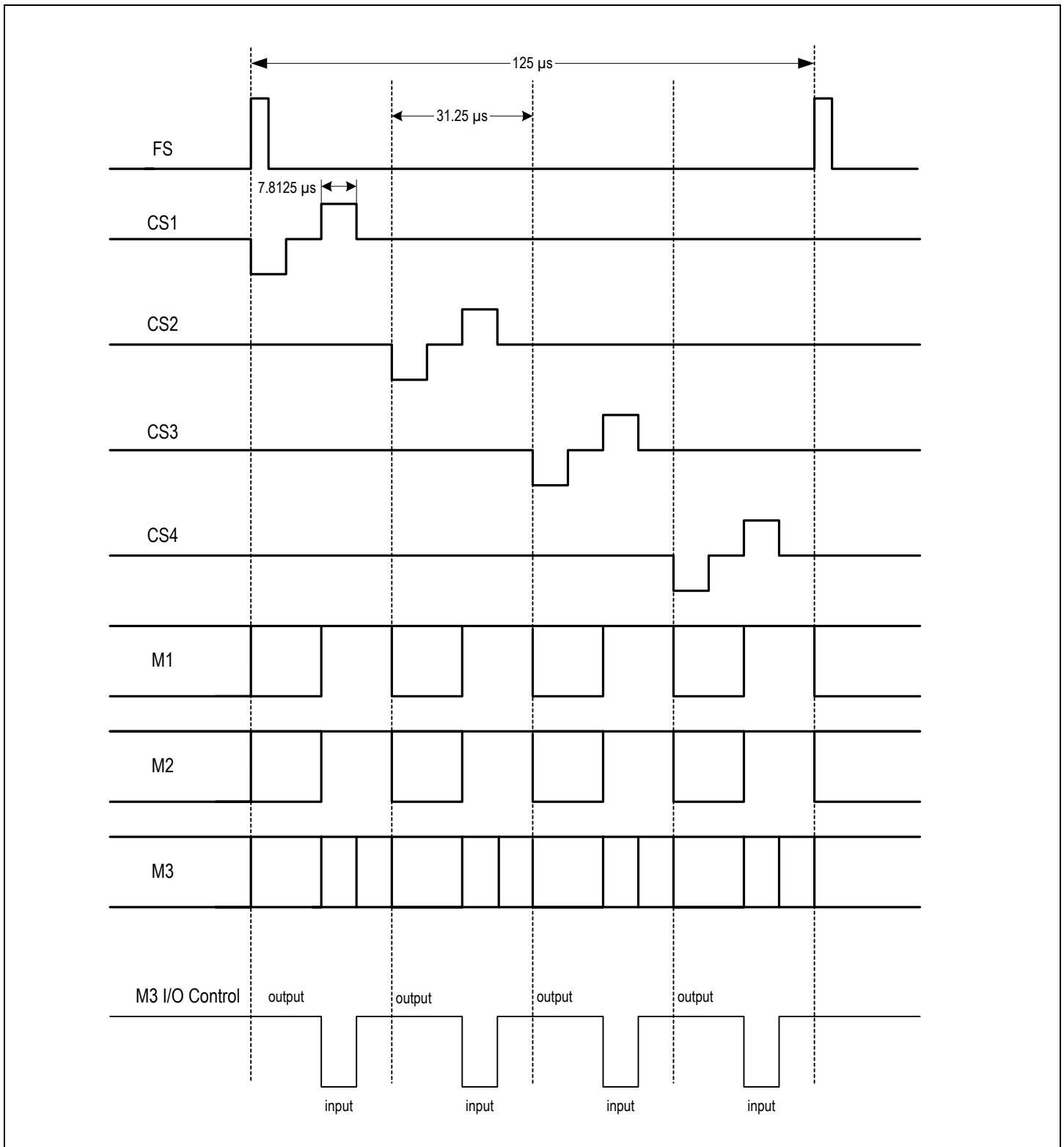

Figure - 39 RSLIC Control Timing Diagram

6.1.2 RSLIC OPERATING MODES

The RSLICs can be operated in nine different modes as shown in Table - 26. The operating mode is configured by the SM[2:0] bits in LREG6 (MPI mode) or in the downstream C/I channel (GCI mode).

The SCAN_EN bit in LREG6 (MPI mode) or downstream C/I channel (GCI mode) determines whether the corresponding RSLIC will be accessed. If this bit is set to 1, the RSLIC will receive data from the CODEC when the corresponding CSn pin is logic low and transmit data to the CODEC when the corresponding CSn pin is logic high (as illustrated in Figure - 39). If this bit is set to 0, the corresponding CSn pin will be set to 1.5 V and the RSLIC will not be accessed.

Table - 26 RSLIC Operating Mode

RSLIC Operating Mode	RSLIC Mode Control Pins			
	CS	M3	M2	M1
Normal Active	0	0	0	0
External Ring	0	0	0	1
Internal Ring	0	0	1	0
Ring Open	0	0	1	1
Tip Open	0	1	0	0
Internal Test	0	1	0	1
Low Power Standby	0	1	1	0
Power Down	0	1	1	1
Overtemp Check (read)	1	X	1	1

- Normal Active

In this mode, a regular call can be performed. Voice can be transferred via the telephone line. Besides providing low-impedance voltage (VBL) feeding to the line, the RSLIC senses, scales and separates transversal and longitudinal line currents.

- External Ring

The RSLIC receives an external ringing signal provided at pins RSP and RSN and feeds it to the telephone line. The RSLIC also provides a ring trip signal for the CODEC via the RT pin.

- Internal Ring

The CODEC generates a balanced ringing signal and outputs it to the RSLIC through the DCP and DCN pins. The RSLIC amplifies this ringing signal and feeds it to the telephone line.

- Ring Open

In ring open mode, the ring power amplifier is switched off and the ring terminal presents a high impedance to the line. This mode is used to measure the leakage current Tip/GND.

- Tip Open

In tip open mode, the tip power amplifier is switched off and the tip terminal presents a high impedance to the line. This mode is used for ground-key detection and the leakage current Ring/GND measurement.

- Internal Test

This mode can be used to test the RSLIC-CODEC chipset without external circuits.

When the RSLIC is set to internal test mode, it works in a similar way as normal active mode. The only difference is that a built-in resistor will be connected between the TIP and RING pins to form a loop for testing. See Figure - 40 for details.

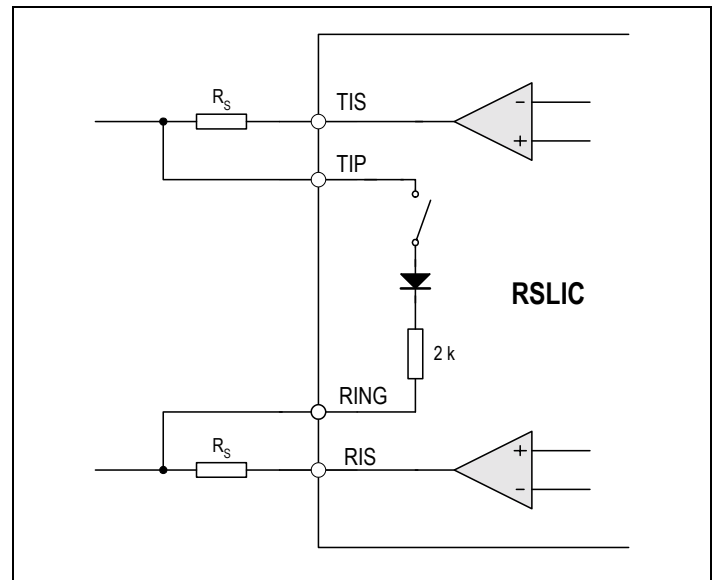

Figure - 40 RSLIC Internal Test Circuit

- Low Power Standby

In this mode, all functions except off-hook detection are switched off to reduce power consumption. Two 2.5 kΩ resistors are connected from TIP to BGND and from RING to VBAT respectively. A simple sense circuit monitors the DC current flowing through these resistors. By calculating the transversal DC current and feeding it to the CODEC, off-hook can be detected. Once the subscriber goes off-hook, the whole chipset should be activated and put into active mode.

- Power Down

In this mode, all functions are disabled, including the off-hook detection. The tip and ring power amplifiers are both switched off so that the power consumption is minimal.

- Overtemp Check

In this mode, the RSLIC will report the temperature state of itself to the CODEC through the M3 pin. This temperature state will be indicated by the OTMP bit in LREG21. If the temperature exceeds the limit (150°C), the RSLIC will be automatically shut down. Every time the OTMP bit changes from 0 to 1, representing the temperature of the RSLIC becoming overloaded, an interrupt will be generated if the OTMP bit is not masked by the OTMP_M bit in LREG18.

6.1.3 CODEC OPERATING MODES

The CODEC can work in five modes: Power Down, Standby, Active, Ramp and Ring. These modes are enabled by setting the P_DOWN, STANDBY, ACTIVE and RAMP bits in LREG6 and RING bit in LREG7 respectively.

- Power Down

This mode is applicable for the line (channel) that is not in use. In this mode, all functions of the CODEC are switched off so that the power dissipation can be minimized. Both AC and DC loops are inactive, no current is fed to the line and the hook switch can not be detected.

Each channel of the CODEC can be powered down individually by setting the P_DOWN bit in corresponding LREG6. If four channels are powered down, the clock cycles fed to the MCLK and BCLK pins should be shut off to achieve the lowest power consumption.

The CODEC can be changed from Power Down mode to any other modes by properly setting LREG6 and LREG7.

- Standby

The standby mode is applicable for system state of subscriber being on-hook. In this mode, only the AC loop is active, all functions except for the off-hook detection are switched off. The sensed voltage from the RSLIC is fed to an analog comparator in the CODEC via VTAC pin. The loop state can be determined by comparing the sensed voltage with a fixed off-hook threshold. If off-hook state is detected, the overall circuits should be activated and switched to the active mode.

- Active

The active mode corresponds to the system state of off-hook. In this mode, both AC and DC loops are active. The RSLIC provides low-impedance voltage (VBL) fed to the line. The RSLIC senses the transversal and longitudinal line currents and separates the transversal current to AC and DC parts. The CODEC scales the currents and converts the AC part of the transversal current to voice data. On the other hand, the CODEC expands the voice data from the PCM bus and converts them to an analog signal. The DC voltage fed to the line can be automatically achieved by the chipset according to certain loop lengths, power optimized solution.

- Ring

This mode corresponds to the system state of ringing. The chipset provides both internal ringing and external ringing modes to be selected. Refer to [Table - 26](#) for details.

If internal ringing mode is selected, an internal balanced ringing signal of up to 70 Vp (for IDT82V1671A) or 52 Vp (for IDT82V1671) can be generated without any external components. In applications that high ringing voltage is not needed, a DC offset can be added to support the DC ring trip detection, which is more reliable than AC ring trip detection.

If an external ring generator and ring relays are used, the RSLIC can be switched to power down mode. An individual operation amplifier in the RSLIC is supplied for ring trip detection.

- Ramp

If ramp mode is selected (LREG6: RAMP = 1), the integrated ramp generator in the CODEC is active and able to generate a ramp signal to help measuring the capacitance. The ramp generator is fully programmable. By programming the ramp slope, ramp start voltage and end voltage, a desired ramp can be generated by the CODEC and output to the line via the RSLIC. With this ramp signal as the source, the line capacitance can be measured via the DC level meter. See [“3.9.6.5 Capacitance Measurement” on page 47](#) for detailed information.

6.2 PLL POWER DOWN

The PLL_PD bit in GREG1 is used to power down the PLL block of the CODEC to reduce the power consumption. If the PLL_PD bit is set to 1, the PLL block is turned off and the DSP operation is disabled. As described above, each of the channels can be individually powered down by setting the corresponding P_DOWN bit in LREG6 to 1. When all four channels and the PLL block are powered down, the lowest power consumption can be achieved.

6.3 PROGRAMMABLE I/O OF THE CODEC

The CODEC provides four programmable IO pins per channel as shown in the following:

IO1:	IO pin with relay-driving capability
IO2:	IO pin with relay-driving capability
IO3:	IO pin with analog input capability
IO4:	IO pin with analog input capability

The four IO pins IO4 to IO1 can be independently configured as input or output by the corresponding control bits IO_C[3] to IO_C[0] in LREG20.

If the IO pins are configured as inputs, the status of the IO pins will be indicated by the IO[3:0] bits in LREG20. If the IO pins are configured as outputs, the data written in the IO[3:0] bits in LREG20 will be sent out through the IO pins.

If the IO1 and IO2 pins are configured as outputs, they are capable of driving external relays. Based on this, the IO1 pin automatically acts as an output to control the external ring relay when external ringing mode is selected. Refer to [“3.4.2 External Ringing Mode” on page 24](#) for details.

If the IO3 and IO4 pins are configured as inputs, they are capable of receiving analog inputs. With this capability external voltages can be fed to the DC level meter via the IO3 and/or IO4 pins to be measured. Refer to [“3.9.6.6 Voltage Measurement” on page 48](#) for details.

The input signals from the four IOs will be filtered by a programmable debounce filter (see [Figure - 41](#)). The output of the debounce filter remains in its present state unless the input remains in the opposite state for the entire period of time programmed by the DB_IO[3:0] bits in LREG11. The debounce period is programmable from 0 ms to 30 ms in steps of 2 ms, corresponding to the minimal debounce time of 2.5 ms to 32.5 ms (a delay time of about 2.5 ms added). The default value of DB_IO[3:0] is '0000'.

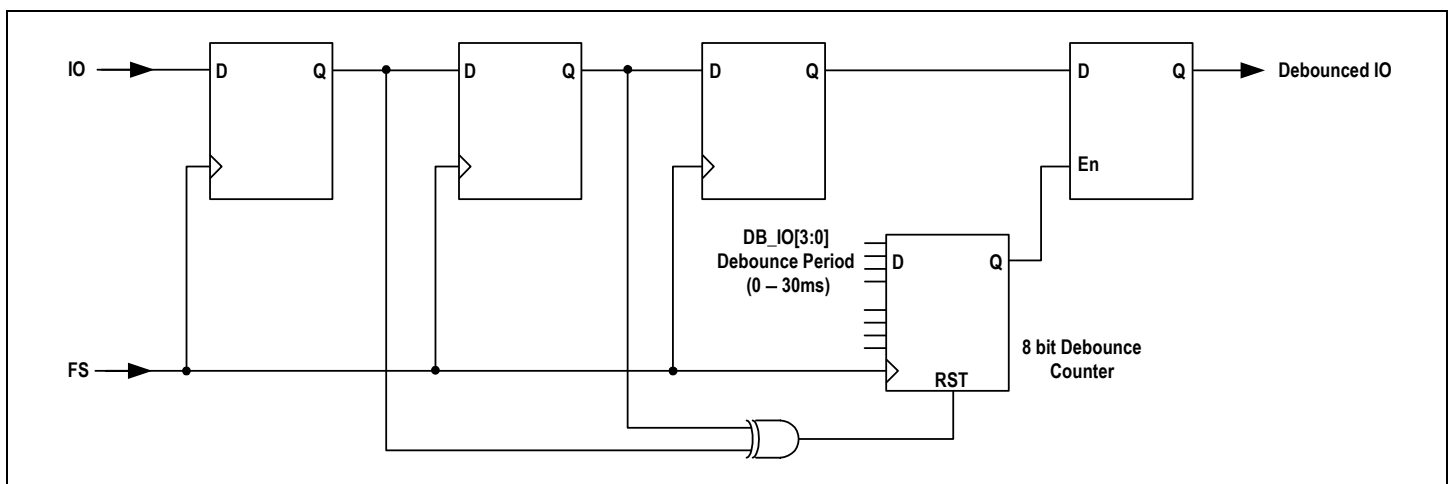

Figure - 41 IO Debounce Filter

The debounced IO data are stored in the IO[3:0] bits in LREG20. The four bits IO[3] to IO[0] have their respective mask bits - IO_M[3] to IO_M[0] in LREG19. Each change of the IO[n] bit will generate an interrupt if its mask bit IO_M[n] is set to 0 (n = 0 to 3).

6.4 INTERRUPT HANDLING

The RSLIC-CODEC chipset is capable of generating interrupts for the following event:

- Off-hook/on-hook detected
- ground-key detected
- ground-key polarity changed
- Ring trip detected
- IO status changed
- Over temperature detected

- Level metering finished
- Special tone detected
- Ramp generation finished

The interrupt status register GREG26 contains the results of hook/ring trip detection and ground-key detection for four channels (two bits per channel). Other interrupt status of each channel is contained by the respective interrupt status registers LREG20 and LREG21 (each interrupt function has one bit). These bits are set when an interrupt is pending for the associated source. Two interrupt mask registers (LREG18 and LREG19) per channel contain one mask bit for each of the above interrupt functions except special tone detected and level metering completed. If a mask bit is set to high, the corresponding interrupt will be masked. Refer to [Table - 27](#) for detailed information.

Table - 27 Interrupt Source and Interrupt Mask

Interrupt Source	Status bits	Interrupt Generating Conditions	Mask Bit
Hook Status	HK[n] bit in GREG26 (n = 0 to 3)	Each change of the HK[n] bit	HK_M bit in LREG18
Ground-key Status	GK[n] bit in GREG26 (n = 0 to 3)	Each change of the GK[n] bit	GK_M bit in LREG18
Ring Trip Status	HK[n] bit in GREG26 (n = 0 to 3)	Each change of the HK[n] bit	HK_M bit in LREG18
RSLIC IO Status	IO[n] bit in LREG20 (n = 0 to 3)	Each change of the IO[n] bit when the corresponding IO pin is configured as an input	IO_M[n] bit in LREG19
Ground-key Polarity	GK_POL bit in LREG21	Each change of the GK_POL bit	GKP_M bit in LREG18
Over Temperature Status	OTMP bit in LREG21	A change of the OTMP bit from 0 to 1	OTMP_M bit in LREG18
Ramp Generation	RAMP_OK bit in LREG21	A change of the RAMP_OK bit from 0 to 1	RAMP_M bit in LREG18
UTD Result	UTD_OK bit in LREG21	A change of the UTD_OK bit from 0 to 1	None
Level Meter Sequence	LM_OK bit in LREG21	A change of the LM_OK bit from 0 to 1	None

In MPI mode, the interrupt output pin $\overline{\text{INT}}/\text{INT}$ will be set to active level if any interrupt is generated. In GCI mode, if any interrupt is generated in a channel, the corresponding INT_CHA or INT_CHB bit in upstream C/I channel will be set to active level. The valid polarity of the $\overline{\text{INT}}/\text{INT}$ pin and the INT_CHA, INT_CHB bits is determined by the INT_POL bit in register GREG24 as shown below:

- INT_POL = 0: active low;
- INT_POL = 1: active high.

In both MPI and GCI mode, the pending interrupts can be cleared by a read operation on the corresponding interrupt register. For example, reading GREG26 clears the interrupts generated by hook/ring trip detection and ground-key detection. Additionally, the CODEC provides a dedicated command to clear all the interrupts at one time. That is, by applying a write operation to GREG26, all the global and local interrupt

status registers will be cleared.

A hardware or power-on reset of the CODEC clears all interrupt status registers and resets the $\overline{\text{INT}}/\text{INT}$ pin to inactive (MPI mode) or resets the INT_CHA and INT_CHB bits in the GCI C/I channel (GCI mode). A software reset applied to one channel clears all local interrupt status registers of that channel but does not effect those of the other channels and the global interrupt status register.

6.5 SIGNAL PATH AND TEST LOOPBACKS

[Figure - 42](#) on the following page shows the main AC and DC signal paths and the integrated analog and digital loopbacks inside the CODEC. Refer to the register descriptions on GREG6 and LREG3 for details.

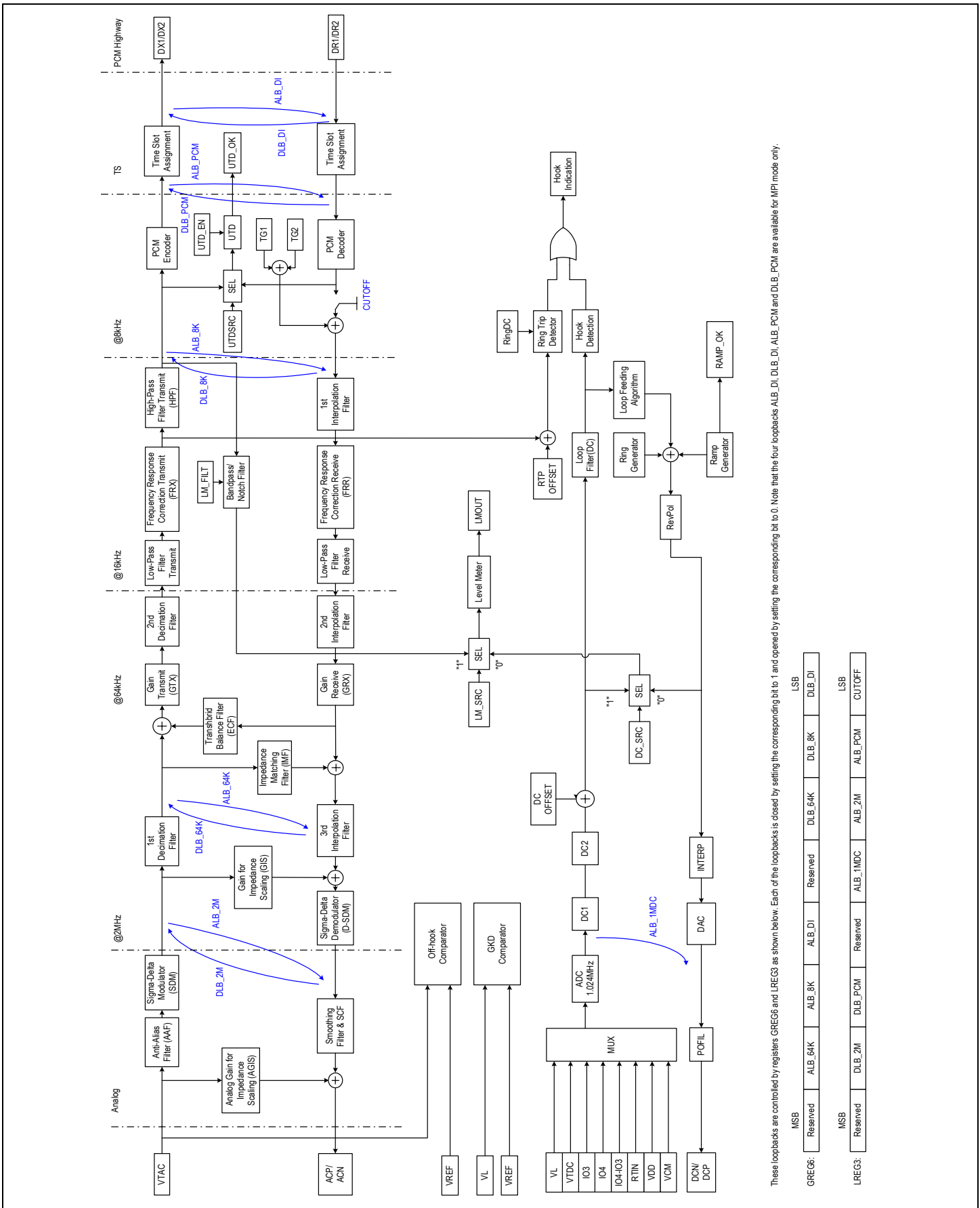

These loopbacks are controlled by registers GRE66 and LREG3 as shown below. Each of the loopbacks is closed by setting the corresponding bit to 1 and opened by setting the corresponding bit to 0. Note that the four loopbacks ALB_DI, DLB_DI, ALB_PCM and DLB_PCM are available for MPI mode only.

MSB		Reserved	ALB_64K	ALB_8K	ALB_DI	Reserved	DLB_64K	DLB_8K	DLB_DI	LSB	
GRE66:											
MSB		Reserved	DLB_2M	DLB_PCM	DLB_8K	Reserved	DLB_1MDC	ALB_2M	ALB_PCM	DLB_DI	CUTOFF
LREG3:											
MSB		Reserved	DLB_2M	DLB_PCM	DLB_8K	Reserved	DLB_1MDC	ALB_2M	ALB_PCM	DLB_DI	CUTOFF
LSB											

Figure - 42 AC/DC Signal Path and Test Loopbacks

6.6 RSLIC POWER ON SEQUENCE

RSLIC power on sequence is as follows:

1. Apply Ground to the AGND and BGND pins;
2. Apply +3.3 V power supply to the VDD pin;
3. Apply battery voltage to the VBH pin;
4. Apply battery voltage to the VBL pin.

Please note that VBH and VBL voltage ranges are as follows:

IDT82V1671A: $-70\text{ V} \leq \text{VBH} \leq -52\text{ V}$, $-52\text{ V} \leq \text{VBL} \leq -20\text{ V}$

IDT82V1671: $-52\text{ V} \leq \text{VBH} \leq -20\text{ V}$, $-52\text{ V} \leq \text{VBL} \leq -20\text{ V}$, and $\text{VBH} \leq \text{VBL}$

If the recommended application circuit (Figure - 49 on page 104 or Figure - 50 on page 105) is used, the above mentioned RSLIC power on sequence is not necessary.

6.7 CODEC POWER ON SEQUENCE

CODEC power on sequence is as follows:

1. Apply Ground to all ground pins;
2. Apply VDD voltage to all power supply pins;
3. Select master clock frequency (via GREG4);
4. Program filter coefficients and other parameters as required.

6.8 DEFAULT STATE AFTER RESET

6.8.1 POWER-ON RESET AND HARDWARE RESET

The CODEC can be reset by a power-on reset or a hardware reset. A hardware reset of the CODEC can be accomplished by setting the signal to the $\overline{\text{RESET}}$ pin to low level for at least 50 μs or setting the HW_RST bit in GREG5 to 1. After a power-on reset or a hardware reset, the default register settings are used. The CODEC will then enter the default state as described below:

1. All four channels are powered down;
2. All loopbacks and cutoff are disabled;
3. The DX1/DU pin is selected for all channels to transmit PCM data. The DR1/DD pin is selected for all channels to receive PCM data.
4. The master clock (MCLK) frequency is 2.048 MHz;
5. In MPI mode, Time Slot 0 to Time Slot 3 are selected for Channel 1 to Channel 4 to transmit and receive data. The PCM data rate is the same as the Bit Clock (BCLK) frequency. The PCM data is

transmitted on the rising edges of BCLK and received on the falling edges of BCLK.

In GCI mode, time slot assignment is determined by the logic levels of the CCLK/S0 and CI/S1 pins. The data rate is always 2.048 MHz, no matter 2.048 MHz or 4.096 MHz is applied to the DCL pin. The GCI data is transferred via the DU/DD pin on rising edges of DCL.

6. A-law is selected;
7. Default register settings are selected;
8. All IO pins are configured as inputs;
9. All maskable interrupts are masked by corresponding mask bits;
10. All function blocks including level meter, UTD unit, FSK generator, tone generators etc., are disabled.

6.8.2 SOFTWARE RESET

Each channel of the CODEC can be individually reset by a software reset command. The RCH_SEL[3:0] bits in GREG5 determine whether Channel 4 to Channel 1 will be software reset or not. Setting the SW_RST bit and any desired bit of RCH_SEL[3:0] to 1 will reset the corresponding channel. Once a software reset is performed, the device will enter the following state:

1. The reset channel(s) are powered down;
2. All test loopbacks and cutoff on the reset channel(s) are disabled;
3. The DX1/DU and DR1/DD pins are selected for the reset channel(s) to transmit and receive PCM data.
4. In MPI mode, Time Slot 0 to Time Slot 3 are selected for Channel 1 to Channel 4 to transmit and receive the PCM data. The PCM data rate is the same as the Bit Clock (BCLK) frequency. The PCM data is transmitted on the rising edges of BCLK and received on the falling edges.

In GCI mode, time slot assignment is determined by the logic levels of the CCLK/S0 and CI/S1 pins. The data rate is always 2.048 MHz, no matter 2.048 MHz or 4.096 MHz is applied to the DCL pin. The GCI data is transferred via DU/DD pin on rising edges of DCL.
5. All default coefficients and register setting except the highpass filter (the HPF bit in LREG5 is set to 1) are selected for the reset channel(s).
6. All IO pins of the reset channel(s) are configured as inputs;
7. All maskable interrupts of the reset channel(s) are masked by corresponding mask bits.

7 ELECTRICAL CHARACTERISTICS

7.1 RSLIC ELECTRICAL CHARACTERISTICS

7.1.1 RSLIC ABSOLUTE MAXIMUM RATINGS

Ratings	Min.	Max.	Unit
Power supply voltage VDD	-0.5	+5	V
VDD-VBH			
IDT82V1671A:		75	V
IDT82V1671:		57	V
Tip/Ring negative pulse		VBH - 0.7	V
Tip/Ring positive pulse		VDD + 0.7	V
ESD voltage (Human body model)		1	kV

Note: Stresses greater than those listed under ABSOLUTE MAXIMUM RATINGS may cause permanent damage to the device. This is a stress rating only and functional operation of the device at these or any other conditions above those indicated in the operational sections of this specification is not implied. Exposure to absolute maximum rating conditions for extended periods may affect reliability.

7.1.2 RSLIC RECOMMENDED OPERATING CONDITIONS

Parameter	Min.	Max.	Unit
Operating temperature	-40	+85	°C
Power supply voltage VDD	+3.135	+3.465	V
Low battery power supply VBL	-52	-20	V
High battery power supply VBH			
IDT82V1671A:	-70	-52	V
IDT82V1671 (VBH ≤ VBL):	-52	-20	V

7.1.3 RSLIC THERMAL INFORMATION

Parameter	Min.	Max.	Unit
Thermal resistance		70	°C/W
Maximum junction temperature (plastic)		150	°C

7.1.4 RSLIC POWER CONSUMPTION

Description	Min.	Typ.	Max.	Units	Test Conditions
RSLIC power consumption in power down mode		90	100	mW	VDD = +3.3 V, VBH = -70 V, VBL = -48 V; without load between the Tip pin and the Ring pin.
RSLIC power consumption in standby mode		160	180	mW	
RSLIC power consumption in normal active mode		400	450	mW	

7.2 CODEC ELECTRICAL CHARACTERISTICS

7.2.1 CODEC ABSOLUTE MAXIMUM RATINGS

Ratings	Min.	Max.	Unit
Supply pins referred to the corresponding ground pin	-0.3	4.6	V
Ground pins referred to any other ground pin	-0.3	+0.3	V
Supply pins referred to any other supply pin	-0.3	+0.3	V
Analog input and output pins	-0.3	3.6	V
Digital input and output pins	-0.3	5.5	V
DC input and output current at any input or output pin (free from latch-up)		100	mA
Storage temperature	-65	125	°C
Ambient temperature under bias	-40	85	°C
Power dissipation		1	W
ESD voltage (Human body model)		2	kV

Note: Stresses greater than those listed under ABSOLUTE MAXIMUM RATINGS may cause permanent damage to the device. This is a stress rating only and functional operation of the device at these or any other conditions above those indicated in the operational sections of this specification is not implied. Exposure to absolute maximum rating conditions for extended periods may affect reliability.

7.2.2 CODEC RECOMMENDED OPERATING CONDITIONS

Description	Min.	Typ.	Max.	Units	Test Conditions
Supply pins referred to the corresponding ground pin	+3.135	+3.3	+3.465	V	
Analog input pins referred to the ground pin	0		+3.3	V	
Ambient temperature	-40		+85	°C	

7.2.3 CODEC DIGITAL INTERFACE

Parameter	Description	Min.	Typ.	Max.	Units	Test Conditions
V _{IL}	Input low voltage			0.8	V	All digital inputs
V _{IH}	Input high voltage	2.0			V	All digital inputs
V _{OL}	Output low voltage			0.8	V	I _L = 4 mA
V _{OH}	Output high voltage	VDD - 0.6			V	I _L = -4 mA
V _{AOL}	Output low voltage on relay driver pin			0.4	V	I _L = 10 mA
V _{AOH}	Output high voltage on relay driver pin	VDD - 0.6			V	I _L = -4 mA
I _I	Input current	-10		10	μA	All digital inputs
I _{OZ}	Output current in high-impedance digital pin	-10		10	μA	
C _I	Input capacitance			5	pF	

7.2.4 CODEC POWER DISSIPATION

Parameter	Description	Min.	Typ.	Max.	Units	Test Conditions
VDD	Power supply voltage		3.3		V	
I _{DD1}	Operating current		95		mA	
I _{DD0}	Standby current			7	mA	

7.3 CHIPSET TRANSMISSION CHARACTERISTICS

0 dBm0 of PCM bus is defined as 0.775 Vrms for 600 Ω load. 0 dBm0 of analog input or output of the CODEC is relative to the 0 dBm0 of the PCM bus output or input. Unless otherwise noted, the analog input is a 0 dBm0, 1020 Hz sine wave. The digital input is a PCM bit stream equivalent to that obtained by passing a 0 dBm0, 1020 Hz sine wave through an ideal encoder. The output level is sin(x)/x-corrected. Typical values are tested at VDD = 3.3 V and TA = 25°C.

7.3.1 ABSOLUTE GAIN

Parameter	Description	Min.	Typ.	Max.	Units	Test Conditions
G _{XA}	Transmit gain, absolute	-0.25		0.25	dB	Signal output of 0 dBm0, normal mode
G _{RA}	Receive gain, absolute	-0.25		0.25	dB	A-law or μ-law, PCM input of 0 dBm0, 1014 Hz

7.3.2 GAIN TRACKING

Parameter	Description	Min.	Typ.	Max.	Units	Test Conditions
G _{TX}	Transmit gain tracking					Tested by sinusoidal method, A-law or μ-law, f = 1014 Hz, reference level -10 dBm0
	+3 dBm0 to -40 dBm0	-0.25		0.25	dB	
	-40 dBm0 to -50 dBm0	-0.5		0.5		
G _{TR}	Receive gain tracking					Tested by sinusoidal method, A-law or μ-law, f = 1014 Hz, reference level -10 dBm0
	+3 dBm0 to -40 dBm0	-0.25		0.25	dB	
	-40 dBm0 to -50 dBm0	-0.5		0.5		
	-50 dBm0 to -55 dBm0	-1.4		1.4		

7.3.3 FREQUENCY RESPONSE

Parameter	Description	Min.	Typ.	Max.	Units	Test Conditions
G _{XR}	Transmit gain, relative to G _{XA}					The highpass filter is enabled.
	f = 50 Hz			-30		
	f = 60 Hz			-30		
	f = 300 Hz to 3000 Hz	-0.25		0.25	dB	
	f = 3000 Hz to 3400 Hz	-0.40		0.25		
	f = 3600 Hz			-0.10		
G _{RR}	Receive gain, relative to G _{RA}					
	f < 300 Hz			0.10		
	f = 300 Hz to 3000 Hz	-0.25		0.25	dB	
	f = 3000 Hz to 3400 Hz	-0.40		0.25		
	f = 3600 Hz			-0.20		
	f ≥ 4600 Hz			-35		

7.3.4 RETURN LOSS

Parameter	Description	Min.	Typ.	Max.	Units	Test Conditions
RL	Return loss (2-wire)	26			dB	300 - 3400 Hz
HB	Hybrid balance (4-wire)	26			dB	300 - 3400 Hz
L-4	Input longitudinal interface loss	52	55		dB	300 - 3400 Hz
L-T	Longitudinal conversion loss	52	55		dB	300 - 3400 Hz

7.3.5 GROUP DELAY

Parameter	Description	Min.	Typ.	Max.	Units	Test Conditions
D_{XR}	Transmit delay, relative to 1800 Hz f = 500 Hz to 600 Hz f = 600 Hz to 1000 Hz f = 1000 Hz to 2600 Hz f = 2600 Hz to 2800 Hz			80 80 50 280	μ s	
D_{RR}	Receive delay, relative to 1800 Hz f < 300 Hz f = 300 Hz to 3400 Hz f = 3600 Hz f \geq 4600 Hz			50 80 120 150	μ s	
DR	Round-trip delay			900	μ s	

7.3.6 DISTORTION

Parameter	Description	Min.	Typ.	Max.	Units	Test Conditions
STD_X	Transmit signal to total distortion ratio -45 dBm0 -40 dBm0 -30 dBm0 -20 dBm0 -10 dBm0 3 dBm0	25 29 34 36 36 36			dB	Output connection: $L_X = 0$ dBr f = 1014 Hz (C message weighted for μ -law, psophometrically weighted for A-law)
STD_R	Receive signal to total distortion ratio -45 dBm0 -40 dBm0 -30 dBm0 -20 dBm0 -10 dBm0 3 dBm0	25 29 34 36 36 36			dB	Input connection: $L_R = 0$ dBr f = 1014 Hz (C message weighted for μ -law, psophometrically weighted for A-law)

7.3.7 NOISE

Parameter	Description	Min.	Typ.	Max.	Units	Test Conditions
N_{XC}	Transmit noise, C message weighted for μ -law			18	dBmC0	
N_{XP}	Transmit noise, psophometrically weighted for A-law			-68	dBm0p	
N_{RC}	Receive noise, C message weighted for μ -law			12	dBmC0	
N_{RP}	Receive noise, psophometrically weighted for A-law			-78	dBm0	
PSR_X	Power supply rejection, transmit f = 300 Hz to 3.4 kHz f = 3.4 kHz to 20 kHz	30 25			dB	VDD = 3.3 VDC+100 mVrms
PSR_R	Power supply rejection, receive f = 300 Hz to 3.4 kHz f = 3.4 kHz to 20 kHz	30 25			dB	VDD = 3.3 VDC+100 mVrms, PCM code is positive LSB one

7.3.8 INTERCHANNEL CROSSTALK

Parameter	Description	Min.	Typ.	Max.	Units	Test Conditions
XT_{X-R}	Transmit to receive crosstalk		-85	-78	dB	300 Hz to 3400 Hz, 0 dBm0 signal into VTAC of interfering channel. Idle PCM code into channel under test
XT_{R-X}	Receive to transmit crosstalk		-85	-80	dB	300 Hz to 3400 Hz, 0 dBm0 PCM code into interfering channel. VTAC = 0 Vrms for channel under test
XT_{X-X}	Transmit to transmit crosstalk		-85	-78	dB	300 Hz to 3400 Hz, 0 dBm0 signal into VTAC of interfering channel. VTAC = 0 Vrms for channel under test
XT_{R-R}	Receive to receive crosstalk		-85	-80	dB	300 Hz to 3400 Hz, 0 dBm0 PCM code into interfering channel. Idle PCM code into channel under test

7.4 CODEC TIMING CHARACTERISTICS

7.4.1 CLOCK TIMING

Symbol	Description	Min.	Typ.	Max.	Units	Test Conditions
t1	CCLK period	122		100 k	ns	
t2	CCLK pulse width	48			ns	
t3	CCLK rise and fall time			25	ns	
t4	BCLK period	122			ns	
t5	BCLK pulse width	48			ns	
t6	BCLK rise and fall time			15	ns	
t7	MCLK pulse width	48			ns	
t8	MCLK rise and fall time			15	ns	
t9	DCL period f = 2.048 kHz f = 4.096 kHz		488 244		ns	
t10	DCL rise and fall time			60	ns	
t11	DCL pulse width	90			ns	

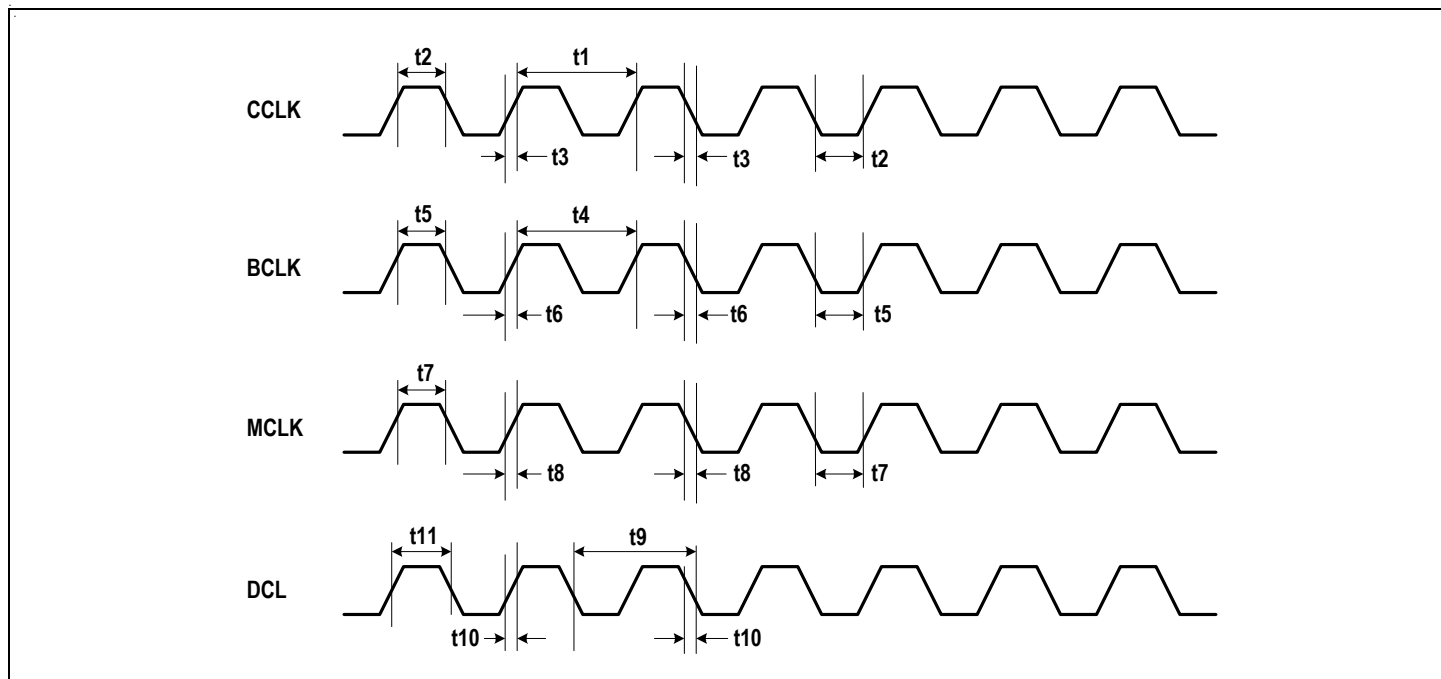

Figure - 43 Clock Timing

7.4.2 MICROPROCESSOR INTERFACE TIMING

Symbol	Description	Min.	Typ.	Max.	Units	Test Conditions
t12	\overline{CS} setup time	15			ns	
t13	\overline{CS} pulse width		$8 * n * t1$ ($n \geq 2$)		ns	
t14	\overline{CS} off time	250			ns	
t15	Input data setup time	30			ns	
t16	Input data hold time	30			ns	
t17	SLIC output latch valid			1000	ns	
t18	Output data turn on delay			50	ns	
t19	Output data hold time	0			ns	
t20	Output data turn off delay			50	ns	
t21	output data valid	0		50	ns	

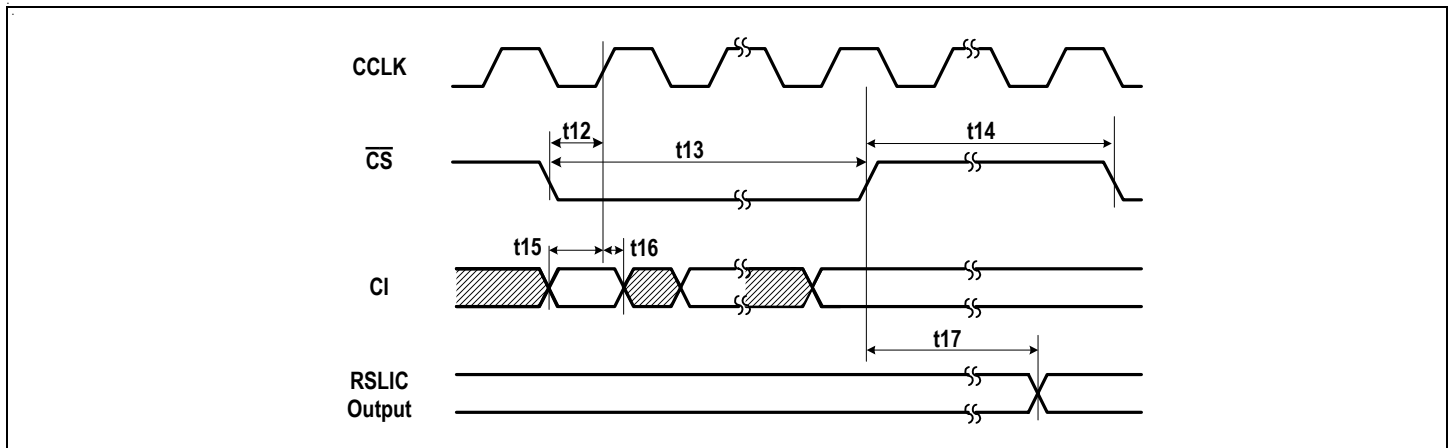

Figure - 44 MPI Input Timing

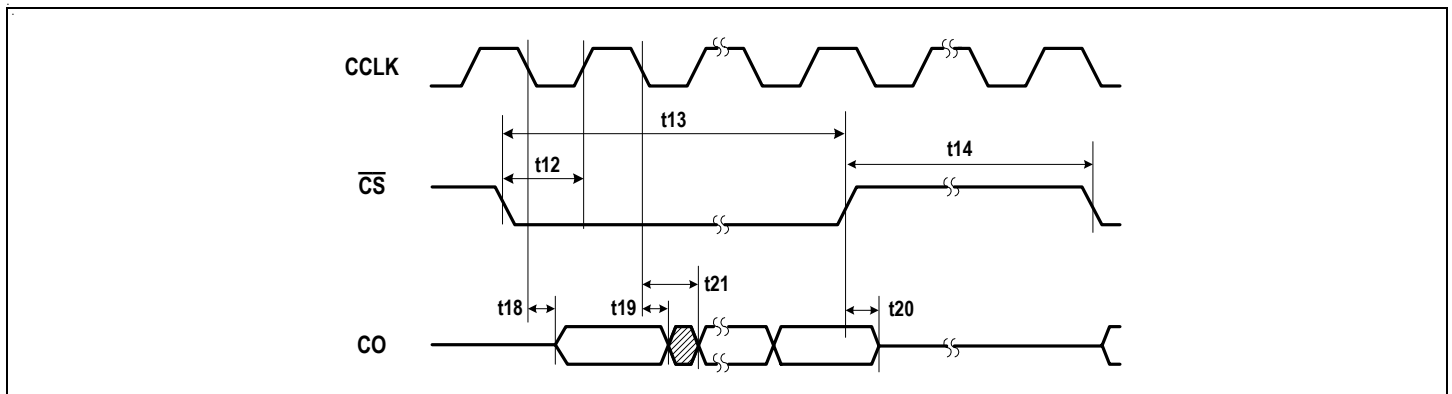

Figure - 45 MPI Output Timing

7.4.3 PCM INTERFACE TIMING

Symbol	Description	Min.	Typ.	Max.	Units	Test Conditions
t22	BCLK period ¹⁾	122			ns	
t23	BCLK high time	48			ns	
t24	FSC period		125		μs	
t25	FSC setup time	25		t22 – 50	ns	
t26	FSC hold time	50			ns	
t27	DR1/DR2 setup time	25			ns	
t28	DR1/DR2 hold time	5			ns	
t29	DX1/DX2 output delay	5		70	ns	
t30	DX1/DX2 output hold time	5		70	ns	
t31	DX1/DX2 output delay to high-Z	5		70	ns	
t32	Delay to $\overline{TSX1}/\overline{TSX2}$ valid ²⁾	5		80	ns	
t33	Delay to $\overline{TSX1}/\overline{TSX2}$ off ³⁾	5		80	ns	

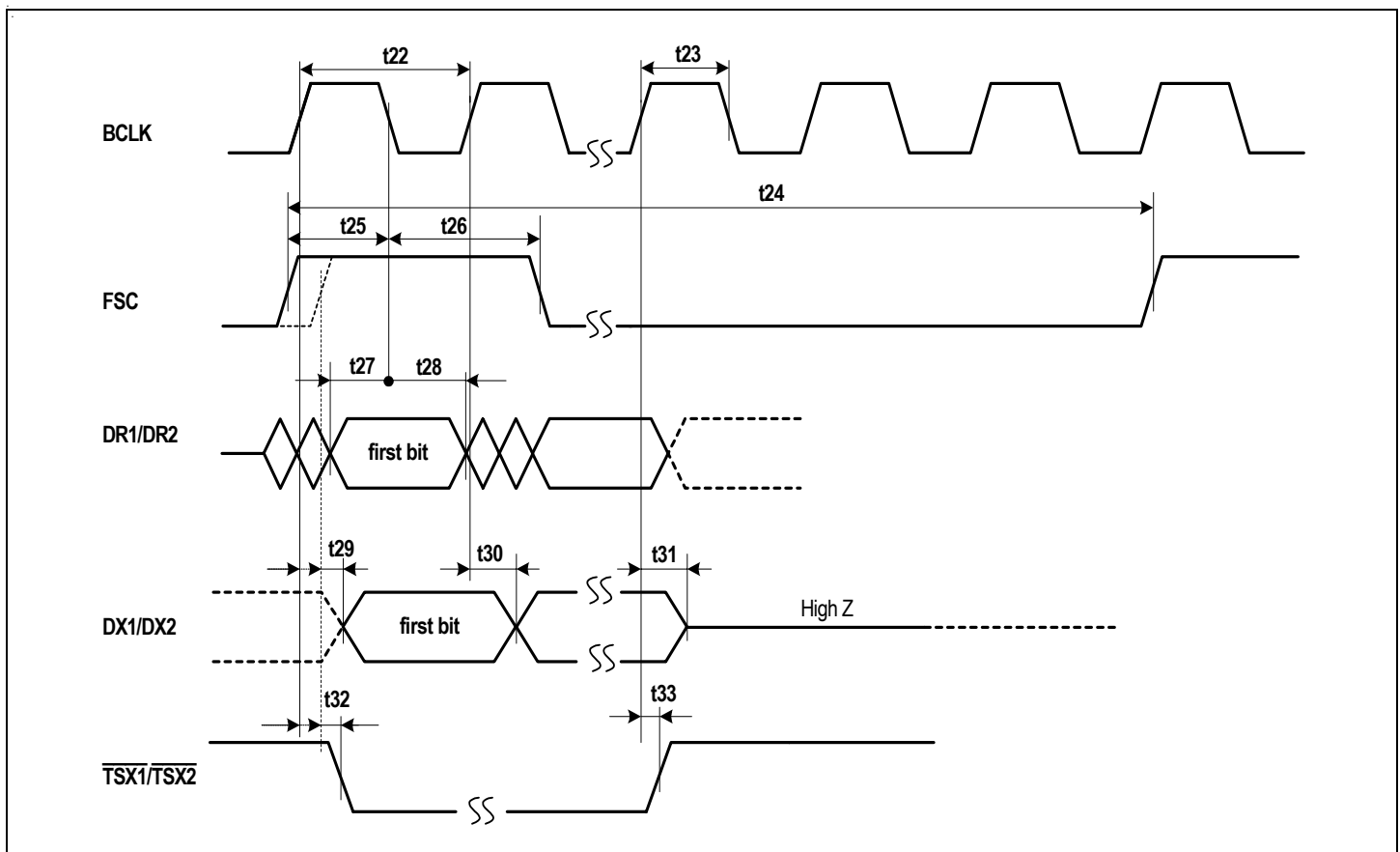

Figure - 46 PCM Interface Timing (Single Clock Mode)

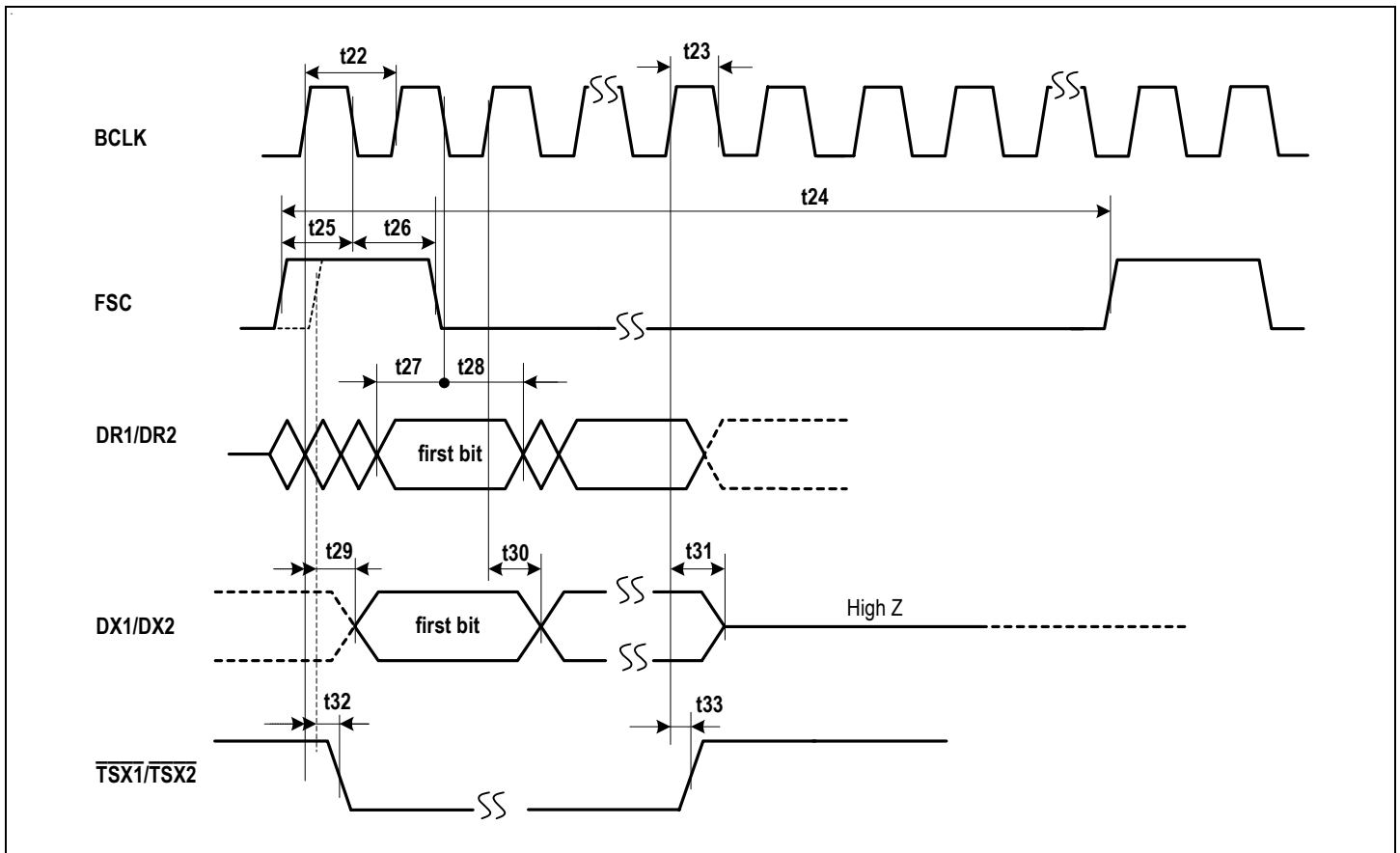

Figure - 47 PCM Interface Timing (Double Clock Mode)

NOTES:

- 1) The BCLK frequency must be an integer multiple of the FSC frequency. The maximum BCLK frequency is 8.192 MHz. The minimum BCLK frequency is 64 kHz in compressed mode and 128 kHz in linear mode if only one channel is used. The minimum BCLK frequency is 256 kHz in compressed mode and 512 kHz in linear mode if all four channels are used.
- 2) $\overline{\text{TSX1}}$ or $\overline{\text{TSX2}}$ typically delays from the FSC for $8 * N * t22$ ns in compressed mode and $16 * N * t22$ ns in linear mode, where N is the specified time slot (value of TT[6:0] in register LREG1).
- 3) t33 is defined to be the time when the $\overline{\text{TSX1}}$ or $\overline{\text{TSX2}}$ output achieves high level.
- 4) Figure - 46 and Figure - 47 show the timing of transmit at the rising edges of BCLK and receive at the falling edges of it.

7.4.4 GCI INTERFACE TIMING

Symbol	Description	Min.	Typ.	Max.	Units	Test Conditions
t34	FSC rise and fall time			60	ns	
t35	FSC setup time	70		t9 – 50	ns	
t36	FSC hold time	50			ns	
t37	FSC high pulse width	130			ns	
t38	DU data delay time			100	ns	
t39	DD data delay time	110			ns	
t40	DD data hold time	50			ns	

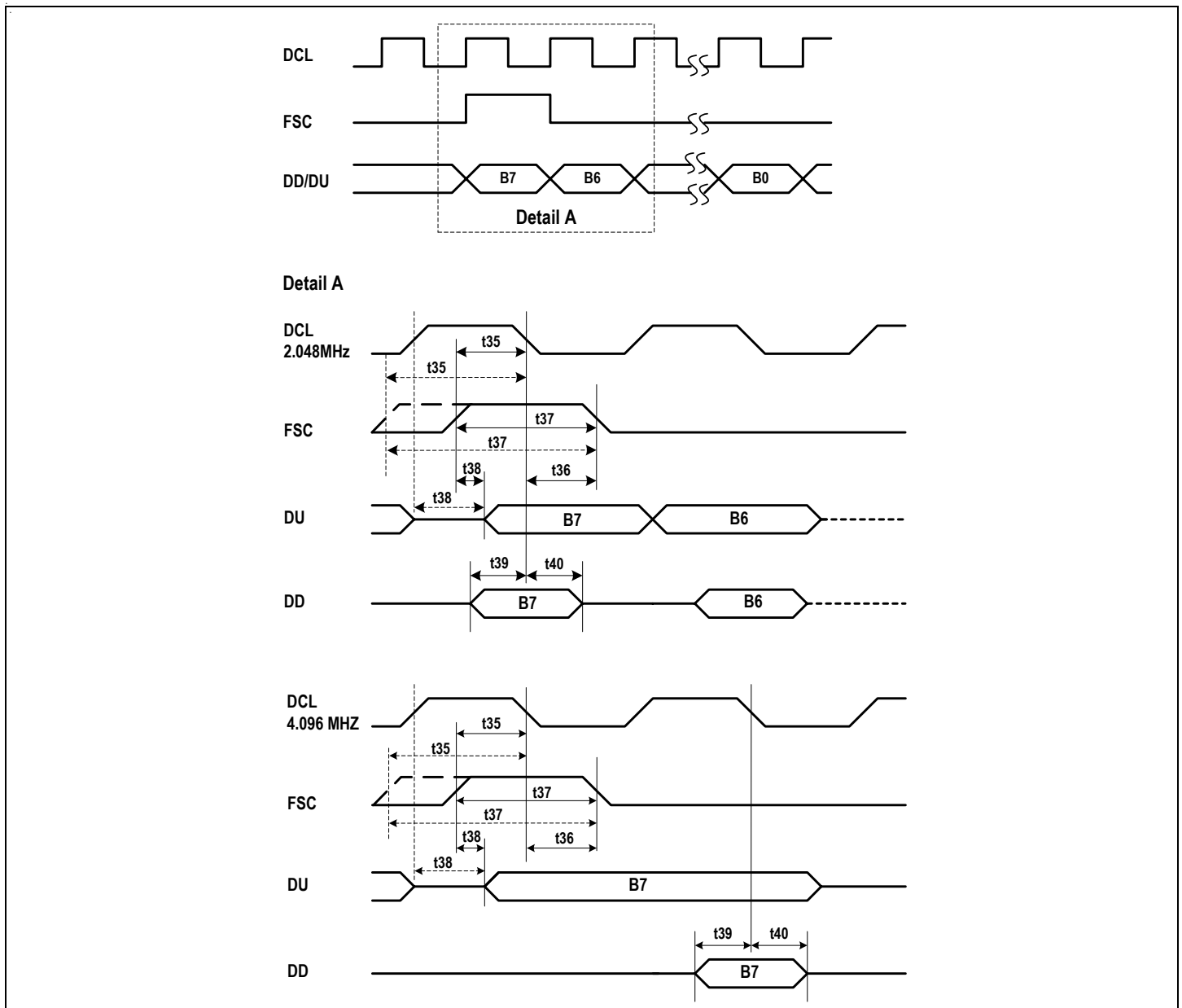

Figure - 48 GCI Interface Timing

8 APPLICATION CIRCUITS

8.1 APPLICATION CIRCUIT FOR THE INTERNAL RINGING MODE

The RSLIC-CODEC chipset can provide an internal ringing signal without any external components. The amplitude of the internal ringing signal can be up to 70 Vp. The off-hook detection and ring trip detection are also internally performed. Figure - 49 shows an application circuit for the internal ringing mode.

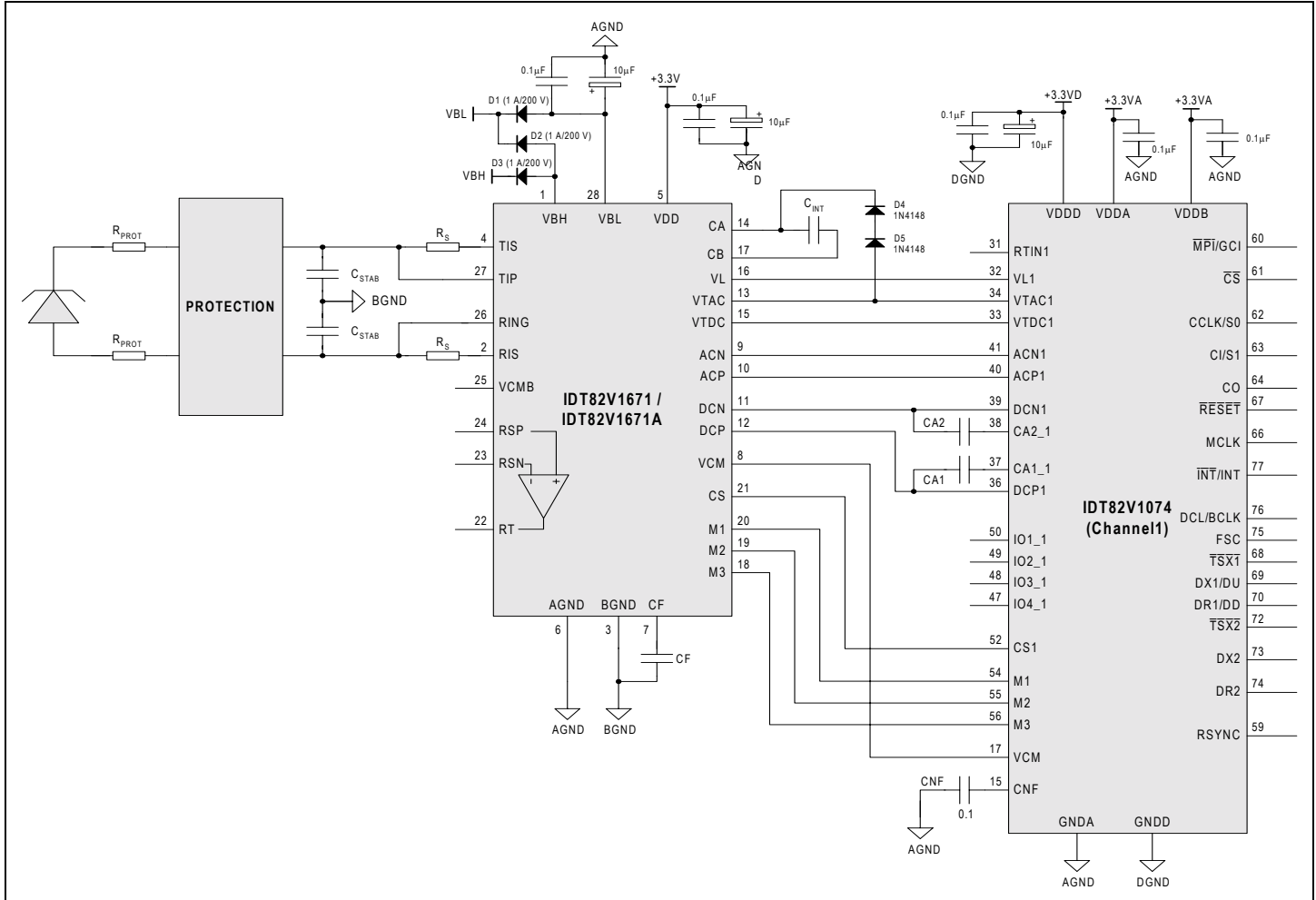

Figure - 49 Application Circuit for the Internal Ringing Mode

8.2 APPLICATION CIRCUIT FOR THE EXTERNAL RINGING MODE

The chipset also supports the external ringing mode. Figure - 50 shows an application circuit for the external ringing mode.

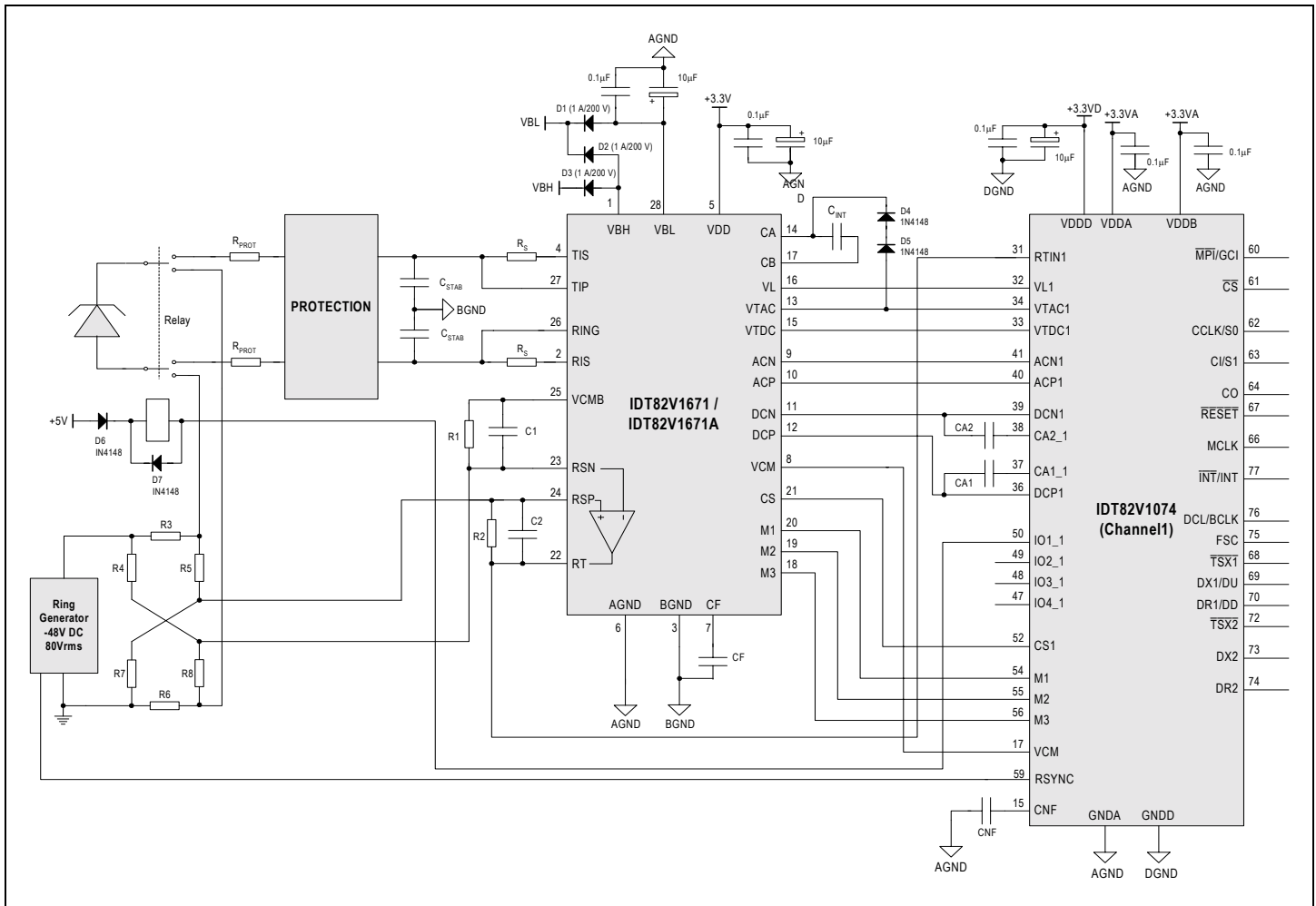

Figure - 50 Application Circuit for the External Ringing Mode

Table - 28 External Components in Application Circuits

Symbol	Value	Unit	Tolerance	Rating
R _{PROT}	50	Ω	±5%	1 W
R _S	50	Ω	±1%	1 W
R1, R2	100	kΩ	±10%	
R3, R6	150	Ω	±10%	1 W
R4, R5, R7, R8	10	MΩ	±10%	
C _{STAB}	22	nF	±10%	100 V
C _{INT}	0.47	μF	±10%	50 V
CA1	0.047	μF	±10%	
CA2	0.047	μF	±10%	
CF	0.47	μF	±10%	50 V
CNF	0.1	μF	±10%	
C1, C2	1	μF	±10%	

9 ORDERING INFORMATION

RSLIC (IDT82V1671):

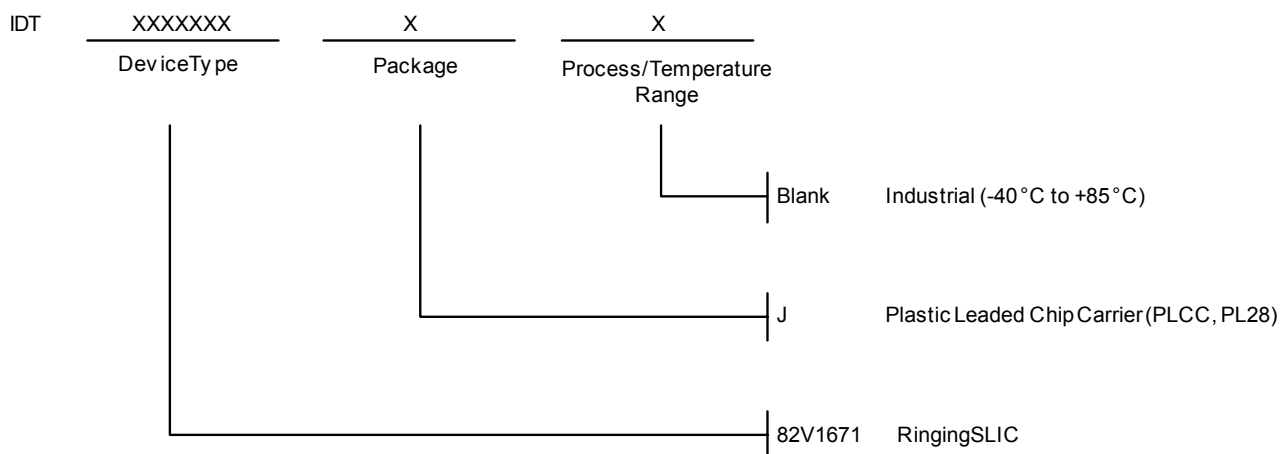

RSLIC (IDT82V1671A):

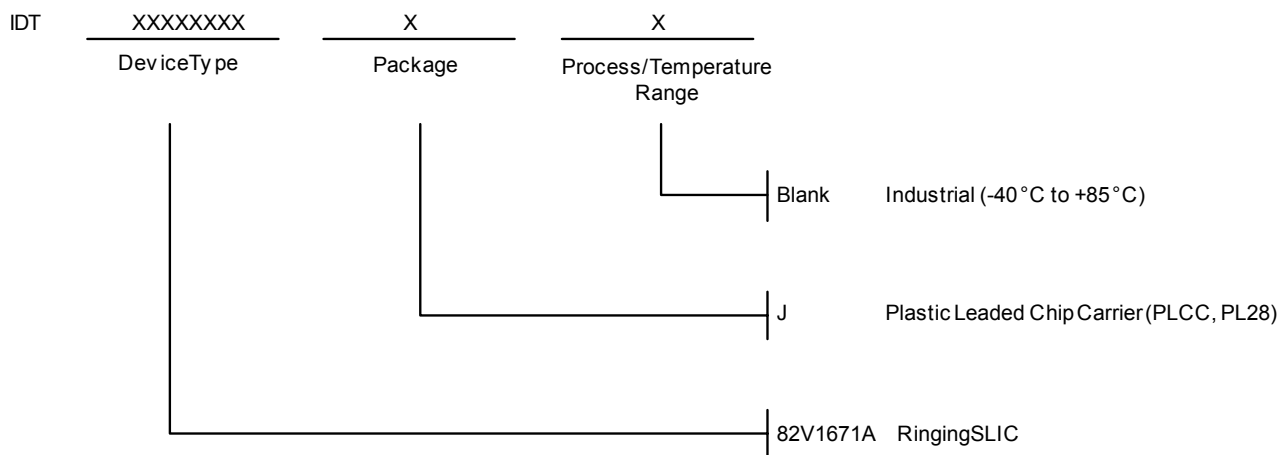

CODEC (IDT82V1074):

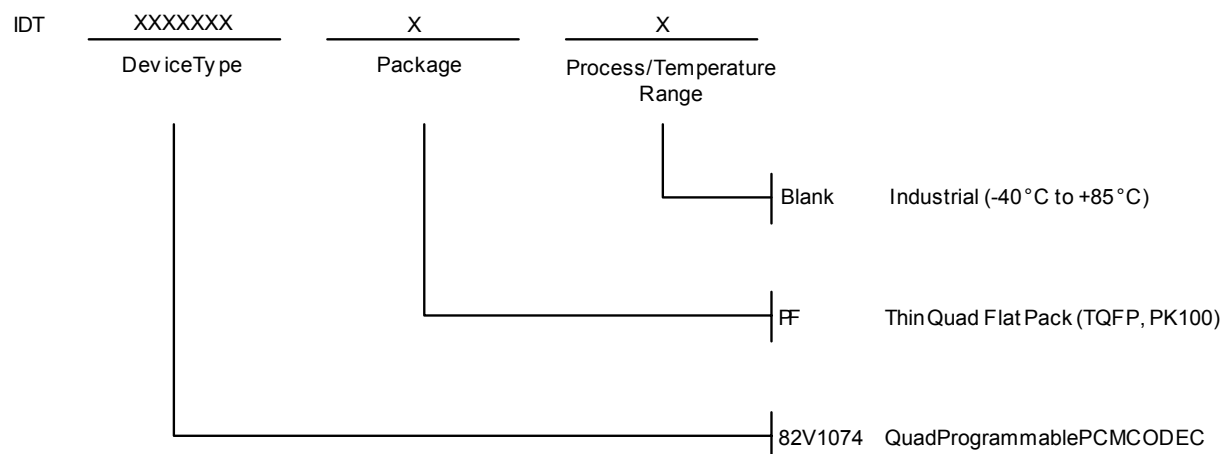

Data Sheet Document History

11/05/2002	pgs. 1, 17, 36, 44 - 48, 60, 63, 77 - 78, 83 - 85, 88, 94, 103, 104
01/09/2003	pgs. 1, 105
02/28/2003	pgs. 29, 66, 93, 103, 104
04/22/2003	pgs. 73, 93, 94
11/18/2003	pgs. 1, 19, 21, 29, 61, 63, 75
02/16/2004	pgs. 18, 19, 21, 26, 29, 60, 61, 63, 73, 75, 77, 83-85, 93, 94
07/29/2004	pgs. 1, 9, 11, 90, 93, 94, 104, 105, 106
09/23/2004	pgs. 51, 65
12/24/2004	pgs. 14, 51, 65



CORPORATE HEADQUARTERS
2975 Stender Way
Santa Clara, CA 95054

for SALES:
800-345-7015 or 408-727-6116
fax: 408-492-8674
www.idt.com

for Tech Support:
email: telecomhelp@idt.com
phone: 408-330-1552