



# Cortina Systems® LXT973 10/100 Mbps Dual-Port Fast Ethernet PHY Transceiver

## Datasheet

---

The Cortina Systems® LXT973 10/100 Mbps Dual-Port Fast Ethernet PHY Transceiver (LXT973 Transceiver) is an IEEE 802.3 compliant, dual-port, Fast Ethernet PHY transceiver that directly supports both 100BASE-TX and 10BASE-T applications. Each port provides a Media Independent Interface (MII) for easy attachment to 10 Mbps and 100 Mbps Media Access Controllers (MACs). The LXT973 Transceiver also provides a Low-Voltage Positive Emitter Coupled Logic (LVPECL) interface per port for use with 100BASE-FX fiber networks. The LXT973 Transceiver incorporates the auto MDI/MDIX feature, allowing it to automatically switch twisted-pair inputs and outputs.

The LXT973 Transceiver is an ideal building block for systems that require two Ethernet ports, such as Internet Protocol (IP) Telephones, Twisted-Pair (TX)-to-Fiber (FX) converter modules, and for telecom applications, such as Telecom Central Office (TCO) and Customer Premise Equipment (CPE) devices.

The LXT973 Transceiver supports full-duplex operation at both 10 Mbps and 100 Mbps. Its operating modes can be set using auto-negotiation, parallel detection, or manual control.

## Applications

- Enterprise switches
- IP telephony switches
- Storage Area Networks
- Multi-port Network Interface Cards (NICs)

## Product Features

- Dual-port Fast Ethernet PHY
- 2.5 V operation
- 3.3 V operation I/O compatibility
- Low power consumption; 250 mW per port typical
- Full dual-port MII interface with extended registers
- Auto MDI/MDIX switch over capability
- Signal Quality Error (SQE) enable/disable
- 100BASE-FX fiber-optic capability on both ports
- Supports both auto-negotiation systems and legacy systems without auto-negotiation capability
- Support for Next Page
- 20 MHz Register Access
- Configurable via MDIO port or external control pins
- Integrated termination resistors
- 100-pin Plastic Quad Flat Package (PQFP)
  - Commercial (0 °C to 70 °C ambient)  
SLXT973QC Transceiver  
EGLXT973QC Transceiver (RoHS Compliant)
  - (-40 °C to +85 °C ambient) (Extended)  
SLXT973QE Transceiver  
EGLXT973QE Transceiver (RoHS Compliant)

**INFORMATION IN THIS DOCUMENT IS PROVIDED IN CONNECTION WITH CORTINA SYSTEMS® PRODUCTS.  
NO LICENSE, EXPRESS OR IMPLIED, BY ESTOPPEL OR OTHERWISE, TO ANY INTELLECTUAL PROPERTY RIGHTS IS  
GRANTED BY THIS DOCUMENT.**

**EXCEPT AS PROVIDED IN CORTINA'S TERMS AND CONDITIONS OF SALE OF SUCH PRODUCTS, CORTINA ASSUMES  
NO LIABILITY WHATSOEVER, AND CORTINA DISCLAIMS ANY EXPRESS OR IMPLIED WARRANTY RELATING TO THE  
SALE AND/OR USE OF CORTINA PRODUCTS, INCLUDING LIABILITY OR WARRANTIES RELATING TO FITNESS FOR A  
PARTICULAR PURPOSE, MERCHANTABILITY OR INFRINGEMENT OF ANY PATENT, COPYRIGHT OR OTHER  
INTELLECTUAL PROPERTY RIGHT.**

Cortina products are not intended for use in medical, life saving, life sustaining, critical control or safety systems, or in nuclear facility applications.

Cortina Systems® and the Cortina Systems logo are the trademarks or registered trademarks of Cortina Systems, Inc. and its subsidiaries in the U.S. and other countries. Other names and brands may be claimed as the property of others.

Copyright © 2001–2007 Cortina Systems, Inc. All rights reserved.

## Contents

<b>1.0</b>	<b>Pin Assignments and Signal Descriptions .....</b>	<b>13</b>
<b>2.0</b>	<b>Signal Descriptions .....</b>	<b>17</b>
<b>3.0</b>	<b>Functional Description.....</b>	<b>23</b>
3.1	Introduction .....	23
3.1.1	Comprehensive Functionality .....	23
3.2	Interface Descriptions .....	23
3.2.1	10/100 Mbps Network Interface .....	23
3.3	MII Operation .....	25
3.3.1	MII Clocks .....	25
3.3.2	Transmit Enable .....	25
3.3.3	Receive Data Valid .....	25
3.3.4	Carrier Sense .....	26
3.3.5	Error Signals .....	26
3.3.6	Collision .....	26
3.3.7	Loopback .....	26
3.3.8	Configuration Management Interface .....	27
3.4	Operating Requirements.....	29
3.4.1	Power Requirements .....	29
3.4.2	Clock Requirements .....	30
3.5	Initialization .....	30
3.5.1	MDIO Control Mode .....	30
3.5.2	Hardware Control Mode .....	30
3.5.3	Power-Down Mode .....	31
3.5.4	Reset .....	31
3.5.5	Hardware Configuration Settings .....	32
3.6	Link Establishment.....	33
3.6.1	Auto-Negotiation .....	33
3.7	Network Media/Protocol Support .....	34
3.7.1	10/100 Mbps Network Interface .....	34
3.7.2	Twisted-Pair Interface .....	35
3.7.3	Fiber Interface.....	35
3.7.4	Fault Detection and Reporting .....	35
3.7.5	Remote Fault .....	35
3.7.6	Far End Fault .....	36
3.8	100 Mbps Operation .....	36
3.8.1	100BASE-X Network Operations .....	36
3.8.2	100BASE-X Protocol Sublayer Operations .....	37
3.8.3	PCS Sublayer .....	37
3.8.4	PMA Sublayer .....	38
3.8.5	Fiber PMD Sublayer .....	39
3.9	10 Mbps Operation .....	40
3.9.1	Polarity Correction .....	40
3.9.2	Dribble Bits .....	40
3.9.3	Link Test .....	40
3.9.4	Link Failure .....	40
3.9.5	Jabber .....	40
3.10	Monitoring Operations .....	41

---

3.10.1	Monitoring Auto-Negotiation .....	41
3.10.2	Per-Port LED Driver Functions .....	41
<b>4.0</b>	<b>Application Information .....</b>	<b>42</b>
4.1	Design Recommendations .....	42
4.1.1	General Design Guidelines .....	42
4.1.2	Power Supply Filtering .....	42
4.1.3	Power and Ground Plane Layout Considerations .....	43
4.1.4	MII Terminations .....	43
4.1.5	The Fiber Interface .....	44
4.1.6	Twisted-Pair Interface .....	45
4.1.7	Magnetics Information .....	45
4.2	Typical Application Circuits .....	46
4.3	Initialization .....	51
4.4	MDIO Control Mode .....	51
4.5	Manual Control Mode .....	51
<b>5.0</b>	<b>Configuration .....</b>	<b>53</b>
<b>6.0</b>	<b>Auto Negotiation .....</b>	<b>55</b>
<b>7.0</b>	<b>Auto-MDI/MDIX .....</b>	<b>56</b>
<b>8.0</b>	<b>100 Mbps Operation .....</b>	<b>57</b>
8.1	Displaying Symbol Errors .....	57
8.1.1	Scrambler Seeding .....	58
8.1.2	Scrambler Bypass .....	58
8.1.3	100BASE-T Link Failure Criteria and Override .....	58
8.1.4	Baseline Wander Correction .....	58
8.1.5	Programmable Tx Slew Rate .....	58
<b>9.0</b>	<b>Fiber Interface .....</b>	<b>60</b>
<b>10.0</b>	<b>10 Mbps Operation .....</b>	<b>61</b>
10.1	Link Test .....	61
10.2	10Base-T Link Failure Criteria and Override .....	61
10.3	SQE (Heartbeat) .....	61
10.4	Jabber .....	61
10.5	Polarity Correction .....	61
10.6	Dribble Bits .....	62
10.7	Transmit Polarity Control .....	62
10.8	PHY Address .....	62
<b>11.0</b>	<b>Clock Generation .....</b>	<b>63</b>
11.1	External Oscillator .....	63
<b>12.0</b>	<b>Register Definitions .....</b>	<b>65</b>
<b>13.0</b>	<b>Magnetics Information .....</b>	<b>75</b>
<b>14.0</b>	<b>Test Specifications .....</b>	<b>76</b>
<b>15.0</b>	<b>Timing Diagrams .....</b>	<b>81</b>



---

<b>16.0 Mechanical Specifications</b> .....	<b>92</b>
16.1 Top Label Marking .....	92
<b>17.0 Product Ordering Information</b> .....	<b>95</b>

## Tables

1	PQFP Pin List.....	14
2	Port 0 Signal Descriptions .....	17
3	Port 1 Signal Descriptions .....	18
4	Network Interface Signal Descriptions.....	19
5	Global Control & Configuration Signal Descriptions .....	20
6	Power Supply Signal Descriptions.....	21
7	Per Port LED and Configuration Signal Descriptions .....	21
8	Carrier Sense, Loopback, and Collision Conditions .....	27
9	Configuration Settings (Hardware Control Interface).....	32
10	LED Configurations .....	41
11	Magnetics Requirements .....	45
12	Mode Control Settings .....	52
13	Configuration Settings (Hardware Control Interface).....	53
14	Common Register Set .....	65
15	Register Bit Descriptions .....	65
16	Control Register (Address 0) .....	66
17	Status Register (Address 1) .....	67
18	PHY Identification Register 1 (Address 2) .....	68
19	PHY Identification Register 2 (Address 3) .....	68
20	Auto-Negotiation Advertisement Register (Address 4).....	69
21	Auto-Negotiation Link Partner Base Page Ability Register (Address 5) .....	70
22	Auto-Negotiation Expansion Register (Address 6) .....	71
23	Auto-Negotiation Next Page Transmit Register (Address 7) .....	72
24	Auto-Negotiation Link Partner Next Page Ability Register (Address 8) .....	72
25	Port Configuration Register (Address 16).....	73
26	Special Function Register (Address 27) .....	74
27	Magnetics Requirements .....	75
28	Absolute Maximum Ratings .....	76
29	Operating Conditions .....	76
30	Digital Input/Output Characteristics <sup>2</sup> .....	77
31	Digital Input/Output Characteristics - SD Pins .....	77
32	Digital Input/Output Characteristics - MII Pins .....	78
33	REFCLK Characteristics.....	78
34	LED Pin Characteristics.....	78
35	100BASE-TX Transceiver Characteristics.....	79
36	10BASE-T Transceiver Characteristics .....	79
37	100BASE-FX Transceiver Characteristics.....	80
38	10BASE-T Link Integrity Timing Characteristics.....	80
39	Twisted-Pair Pins.....	80
40	MII - 100BASE-TX Transmit Timing Parameters - 4B Mode .....	81
41	MII - 100BASE-TX Receive Timing Parameters - 4B Mode .....	82
42	100BASE-FX Transmit Timing Parameters .....	83
43	100BASE-FX Receive Timing Parameters .....	84
44	MII - 10BASE-T Transmit Timing Parameters (Parallel Mode).....	85
45	MII - 10BASE-T Receive Timing Parameters (Parallel Mode).....	86
46	10BASE-T SQE (Heartbeat) Timing Parameters .....	87
47	10BASE-T Jab and Unjab Timing Parameters .....	87
48	Fast Link Pulse Timing Parameters.....	88

---

49	MDIO Timing Parameters .....	89
50	Power-Up Timing Parameters .....	90
51	RESET Pulse Width and Recovery Timing Parameters .....	91
52	Product Ordering Information .....	95

## Figures

1	Block Diagram .....	12
2	Pin Assignments .....	13
3	Interfaces .....	24
4	Loopback Paths .....	27
5	Management Interface Read Frame Structure .....	28
6	Management Interface Write Frame Structure .....	28
7	Port Address Scheme .....	29
8	Auto-Negotiation Operation .....	34
9	100BASE-X Frame Format .....	36
10	Protocol Sublayers .....	38
11	Typical LED Implementation .....	41
12	Power and Ground Supply Connections .....	46
13	Typical Twisted-Pair Interface .....	47
14	Recommended LXT973 Transceiver Transceiver-to-3.3 V Fiber Transceiver Interface Circuitry ..	48
15	Recommended LXT973 Transceiver-to-5 V Fiber Transceiver Interface Circuitry .....	49
16	ON Semiconductor* Triple PECL-to-LVPECL Logic Translator .....	50
17	Typical MII Interface .....	50
18	Initialization Sequence .....	52
19	100BASE-TX Frame Format .....	57
20	100BASE-TX Data Path .....	57
21	100BASE-TX Reception with no Errors .....	58
22	100BASE-TX Reception with Invalid Symbol .....	59
23	100BASE-TX Transmission with no Errors .....	59
24	100BASE-TX Transmission with Collision .....	59
25	MII 10BASE-T DTE Mode Auto-Negotiation .....	63
26	100BASE-T DTE Mode Auto-Negotiation .....	63
27	Link Down Clock Transition .....	64
28	PHY Identifier Bit Mapping .....	68
29	100BASE-TX Transmit Timing - 4B Mode .....	81
30	100BASE-TX Receive Timing - 4B Mode .....	82
31	100BASE-FX Transmit Timing .....	83
32	100BASE-FX Receive Timing .....	84
33	10BASE-T Transmit Timing (Parallel Mode) .....	85
34	10BASE-T Receive Timing (Parallel Mode) .....	86
35	10BASE-T SQE (Heartbeat) Timing .....	87
36	10BASE-T Jab and Unjab Timing .....	87
37	Fast Link Pulse Timing .....	88
38	FLP Burst Timing .....	88
39	MDIO Input Timing .....	89
40	MDIO Output Timing .....	89
41	Power-Up Timing .....	90
42	RESET Pulse Width and Recovery Timing .....	91
43	Mechanical Specifications .....	92
44	Example of Top Marking Information Labeled as Cortina Systems, Inc. .....	93
45	Sample PQFP Package (marked as Intel*) – LXT973QC Transceiver .....	93
46	Sample Pb-Free (RoHS-Compliant) PQFP Package (marked as Intel*) – Intel* EGLX973QC Transceiver .....	94
47	Ordering Information – Sample .....	96



## Revision History

<b>Revision 6.0</b> <b>Revision Date: 13 July 2007</b>
Updated the product top marking diagrams

<b>Revision 5.0</b> <b>Revision Date: 06 July 2007</b>
First release of this document from Cortina Systems, Inc.

<b>Revision#: 004</b> <b>Revision Date: 29 November 2005</b>
Modified <a href="#">Figure 2, Pin Assignments</a> , on page 13.
Added <a href="#">Section 16.1, Top Label Marking</a> , on page 92.
Modified <a href="#">Table 52, Product Ordering Information</a> , on page 95.
Modified <a href="#">Figure 47, Ordering Information – Sample</a> , on page 96.

<b>Revision Number: 003</b> <b>Revision Date: 20 January 2004</b>
First paragraph: Modified first sentence Modified third sentence - Changed "pseudo-ECL" to "Low Voltage PECL" Removed bullet under Product Features: Integrated termination resistors.
Modified descriptions for pins 35, 36, 93, and 94 in <a href="#">Table 2 "LXT973 Port 0 Signal Descriptions"</a> .
Changed the last word for SD0 and SD1 under Description from "Low" to "GND" in <a href="#">Table 4 "LXT973 Network Interface Signal Descriptions"</a> .
Modified descriptions for pins 7 and 8 in <a href="#">Table 7 "LXT973 Per Port LED and Configuration Signal Descriptions"</a> .
Changed PECL to LVPECL in second to last sentence in the first paragraph under <a href="#">Section 3.1, "Introduction"</a> .
Replaced text under <a href="#">Section 3.2.1.3, "Fiber Interface"</a> .
Modified text in second paragraph under <a href="#">Section 3.5.3, "Power-Down Mode"</a> .
Modified bullets under <a href="#">Section 3.5.3.1, "Hardware Power-Down"</a> .
Changed Register 11 to Register bit 0.11 under <a href="#">Section 3.5.3.2, "Software Power-Down"</a> .
Changed PECL to LVPECL in third paragraph, first sentence under <a href="#">Section 3.8.1, "100BASE-X Network Operations"</a> .
Modified <a href="#">Figure 10 "Protocol Sublayers"</a> (changed "PECL Interface" to "LVPECL Interface").
Replaced text under <a href="#">Section 3.8.5, "Fiber PMD Sublayer"</a> .
Modified first sentence under <a href="#">Section 4.1.4, "MII Terminations"</a> .
Replaced text under <a href="#">Section 4.1.5, "The Fiber Interface"</a> .
Modified text under <a href="#">Section 4.1.7, "Magnetics Information"</a> .
Replaced <a href="#">Figure 14 "Recommended LXT973-to-3.3 VFiber Transceiver Interface Circuitry"</a> .

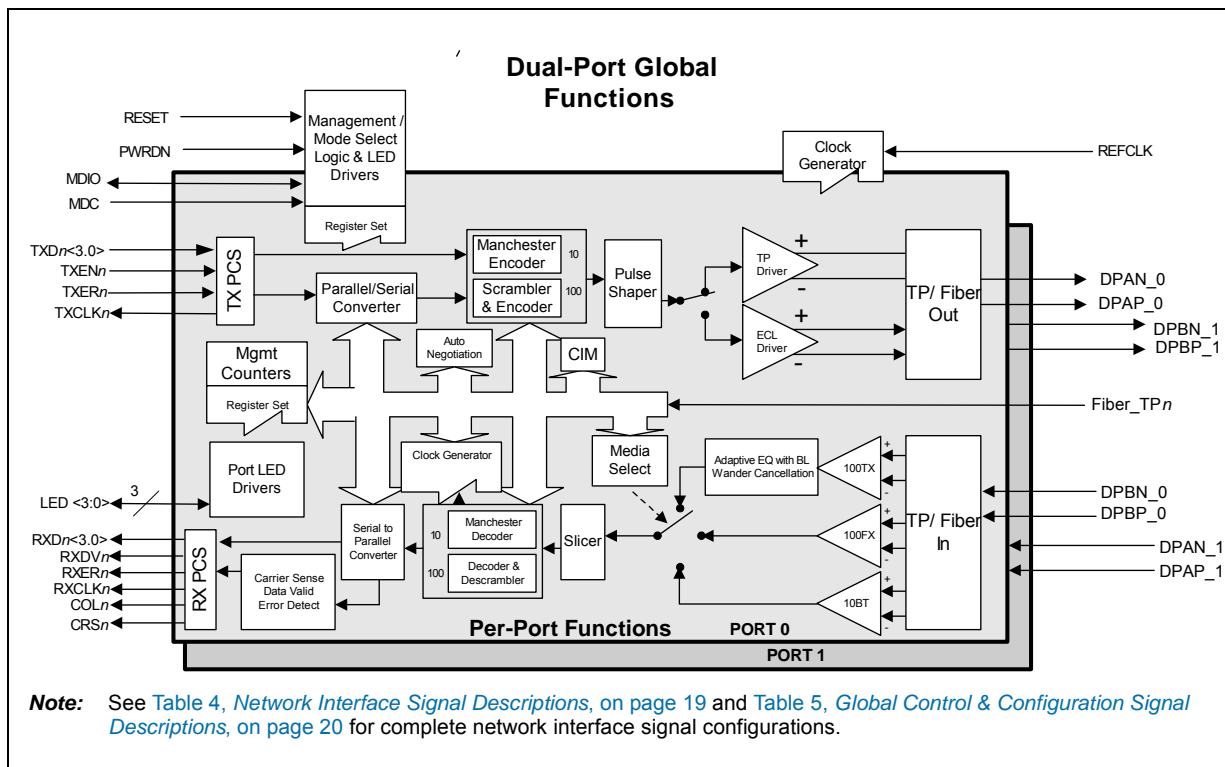
<b>Revision Number: 003</b> <b>Revision Date: 20 January 2004</b>
Added <a href="#">Figure 15</a> "Recommended LXT973-to-5 VFiber Transceiver Interface Circuitry".
Added <a href="#">Figure 16</a> "ON Semiconductor* Triple PECL-to-LVPECL Logic Translator".
Changed PECL to LVPECL in first paragraph, second sentence under <a href="#">Section 9.0, "Fiber Interface"</a> .
Modified table note 2 in <a href="#">Table 29 "Port Configuration Register (Address 16)"</a> (changed "hardware pins" to "FIBER_TPN").
Modified table note 2 in <a href="#">Table 41 "Digital Input/Output Characteristics2"</a> – (changed "applies to all pins except MII..." to "applies to all pins except SD, MII...").
Added <a href="#">Table 42 "Digital Input/Output Characteristics - SD Pins"</a> .
In <a href="#">Table 46 "100BASE-TX Transceiver Characteristics"</a> : Changed "Peak differential output voltage (single ended)" to "Peak-to-peak differential output voltage". Changed "VOP" to "V <sub>diff-p</sub> ", and removed footnote #2 (and all references).
Modified <a href="#">Table 63 "Product Ordering Information"</a> .

<b>Revision Number: 002</b> <b>Revision Date: June 2002</b>
<a href="#">Figure 1 "LXT973 Block Diagram"</a> : Added note to diagram.
Under <a href="#">Section 3.8.4, "PMA Sublayer"</a> : Removed <a href="#">Table 10: 4B/5B Coding</a> .
<a href="#">Section 3.10.1, "Monitoring Auto-Negotiation"</a> : Removed paragraphs 3 and 4, and <a href="#">Figure 11</a> .
Under <a href="#">Section 8.1, "Displaying Symbol Errors"</a> : Removed <a href="#">Table 16: 4B/5B Coding</a> .
<a href="#">Section 12.0, "Register Definitions"</a> Removed "multiple 11-bit registers, with" from first sentence.
<a href="#">Table 20 "PHY Identification Register 2 (Address 3)"</a> : Changed default for Register bits 3.9:4 from "001110" to "100001".
<a href="#">Table 29 "Absolute Maximum Ratings"</a> Modified Power Supply: added VCCA, VCC, VCCPECL, VCCIO information. Added three table notes.
<a href="#">Table 31 "Digital Input/Output Characteristics2"</a> Modified table note 2.
<a href="#">Table 32 "Digital Input/Output Characteristics - MII Pins"</a> Removed "Driver Output Impedance."
<a href="#">Table 34 "LED Pin Characteristics"</a> Added MAX value to Output High Current.
<a href="#">Table 35 "100BASE-TX Transceiver Characteristics"</a> Added Typ values.
<a href="#">Table 36 "10BASE-T Transceiver Characteristics"</a> Added/replaced Typ values. Removed "Receiver Input Impedance."
<a href="#">Table 37 "100BASE-FX Transceiver Characteristics"</a> Added Typ values
<a href="#">Table 38 "10BASE-T Link Integrity Timing Characteristics"</a> Added Typ value for Link Pulse Width
Added <a href="#">Table 39 "Twisted-Pair Pins"</a> .
Modified <a href="#">Table 40 on page 77</a> through <a href="#">Table 49 on page 85</a> .

---

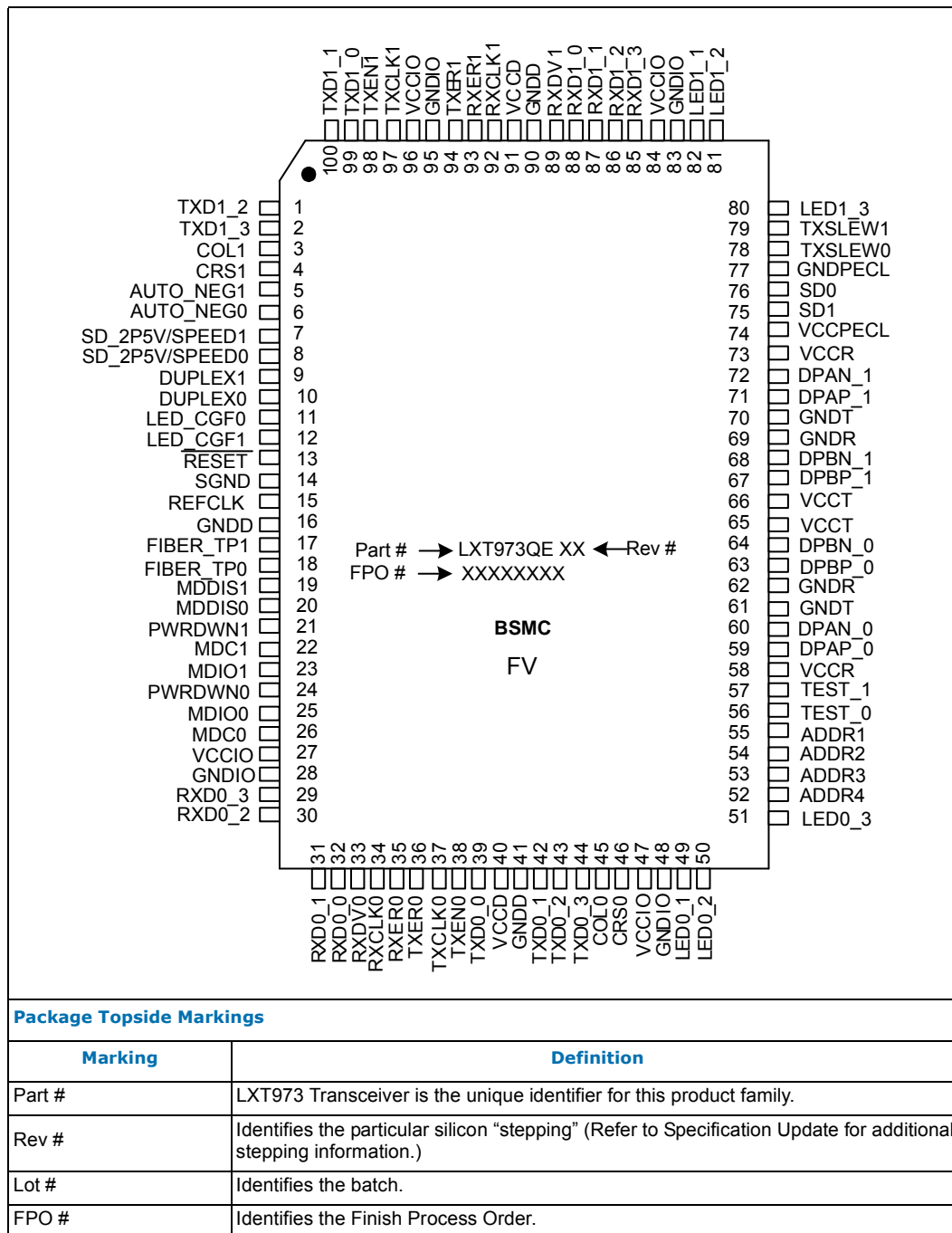
<b>Revision Number: 002</b> <b>Revision Date: June 2002</b>
Added <a href="#">Figure 39 "Power-Up Timing"</a> and <a href="#">Table 50 "Power-Up Timing Parameters"</a> .
Added <a href="#">Figure 40 "RESET Pulse Width and Recovery Timing"</a> and <a href="#">Table 51 "RESET Pulse Width and Recovery Timing Parameters"</a>
<b>Section A, "Product Ordering Information":</b> Added product ordering information table and diagram.
<b>Revision Number: 001</b> <b>Revision Date: May 2001</b>
Initial Release (Preliminary datasheet)

**Figure 1 Block Diagram**



## 1.0 Pin Assignments and Signal Descriptions

Figure 2 Pin Assignments



**Table 1 PQFP Pin List (Sheet 1 of 3)**

Pin	Signal Names	Type <sup>1</sup>	Reference for Full Description
1	TXD1_2	I	Table 3 on page 18
2	TXD1_3	I	Table 3 on page 18
3	COL1	O, S T	Table 3 on page 18
4	CRS1	O, S T	Table 3 on page 18
5	AUTO_NEG1	I	Table 7 on page 21
6	AUTO_NEG0	I	Table 7 on page 21
7	SD_2P5V/SPEED1	I	Table 7 on page 21
8	SD_2P5V/SPEED0	I	Table 7 on page 21
9	DUPLEX1	I	Table 7 on page 21
10	DUPLEX0	I	Table 7 on page 21
11	LED_CGF0	I	Table 5 on page 20
12	LED_CGF1	I	Table 5 on page 20
13	RESET	I	Table 5 on page 20
14	SGND	–	Table 6 on page 21
15	REFCLK	I	Table 5 on page 20
16	GNDD	–	Table 6 on page 21
17	FIBER_TP1	I	Table 7 on page 21
18	FIBER_TP0	I	Table 7 on page 21
19	MDDIS1	I	Table 3 on page 18
20	MDDIS0	I	Table 2 on page 17
21	PWRDWN1	I	Table 7 on page 21
22	MDC1	I	Table 3 on page 18
23	MDIO1	I/O	Table 3 on page 18
24	PWRDWN0	I	Table 7 on page 21
25	MDIO0	I/O	Table 2 on page 17
26	MDC0	I	Table 2 on page 17
27	VCCIO	–	Table 6 on page 21
28	GNDIO	–	Table 6 on page 21
29	RXD0_3	O, TS	Table 2 on page 17
30	RXD0_2	O, TS	Table 2 on page 17
31	RXD0_1	O, TS	Table 2 on page 17
32	RXD0_0	O, TS	Table 2 on page 17
33	RXDV0	O, TS	Table 2 on page 17

1. AI = Analog Input, AO = Analog Output, I = Input, O = Output, OD = Open Drain output, ST = Schmitt Triggered input, TS = Three-State-able output, SL = Slew-rate Limited output, IP = Weak Internal Pull-up, ID = Weak Internal Pull-down.

**Table 1**      **PQFP Pin List (Sheet 2 of 3)**

Pin	Signal Names	Type <sup>1</sup>	Reference for Full Description
34	RXCLK0	O, TS	Table 2 on page 17
35	RXER0	O, TS	Table 2 on page 17
36	TXER0	I	Table 2 on page 17
37	TXCLK0	O, TS	Table 2 on page 17
38	TXEN0	I	Table 2 on page 17
39	TXD0_0	I	Table 2 on page 17
40	VCCD	–	Table 6 on page 21
41	GNDD	–	Table 6 on page 21
42	TXD0_1	I	Table 2 on page 17
43	TXD0_2	I	Table 2 on page 17
44	TXD0_3	I	Table 2 on page 17
45	COL0	O, TS	Table 2 on page 17
46	CRS0	O, TS	Table 2 on page 17
47	VCCIO	–	Table 6 on page 21
48	GNDIO	–	Table 6 on page 21
49	LED0_1	O, OD	Table 7 on page 21
50	LED0_2	O, OD	Table 7 on page 21
51	LED0_3	O, OD	Table 7 on page 21
52	ADDR4	I	Table 5 on page 20
53	ADDR3	I	Table 5 on page 20
54	ADDR2	I	Table 5 on page 20
55	ADDR1	I	Table 5 on page 20
56	TEST_0	I	Table 5 on page 20
57	TEST_1	I	Table 5 on page 20
58	VCCR	–	Table 6 on page 21
59	DPAP_0	AI/AO, SL	Table 4 on page 19
60	DPAN_0	AI/AO, SL	Table 4 on page 19
61	GNDT	–	Table 6 on page 21
62	GNDR	–	Table 6 on page 21
63	DPBP_0	AI/AO, SL	Table 4 on page 19
64	DPBN_0	AI/AO, SL	Table 4 on page 19
65	VCCT	–	Table 6 on page 21
66	VCCT	–	Table 6 on page 21
67	DPBP_1	AI/AO, SL	Table 4 on page 19

1. AI = Analog Input, AO = Analog Output, I = Input, O = Output, OD = Open Drain output, ST = Schmitt Triggered input, TS = Three-State-able output, SL = Slew-rate Limited output, IP = Weak Internal Pull-up, ID = Weak Internal Pull-down.

**Table 1**      **PQFP Pin List (Sheet 3 of 3)**

Pin	Signal Names	Type <sup>1</sup>	Reference for Full Description
68	DPBN_1	AI/AO, SL	Table 4 on page 19
69	GNDR	–	Table 6 on page 21
70	GNDT	–	Table 6 on page 21
71	DPAP_1	AI/AO, SL	Table 4 on page 19
72	DPAN_1	AI/AO, SL	Table 4 on page 19
73	VCCR	–	Table 6 on page 21
74	VCCPECL	–	Table 6 on page 21
75	SD1	I	Table 4 on page 19
76	SD0	I	Table 4 on page 19
77	GNDPECL	–	Table 6 on page 21
78	TxSLEW0	I	Table 5 on page 20
79	TxSLEW1	I	Table 5 on page 20
80	LED1_3	O, OD	Table 7 on page 21
81	LED1_2	O, OD	Table 7 on page 21
82	LED1_1	O, OD	Table 7 on page 21
83	GNDIO	–	Table 6 on page 21
84	VCCIO	–	Table 6 on page 21
85	RXD1_3	O, TS	Table 3 on page 18
86	RXD1_2	O, TS	Table 3 on page 18
87	RXD1_1	O, TS	Table 3 on page 18
88	RXD1_0	O, TS	Table 3 on page 18
89	RXDV1	O, TS	Table 3 on page 18
90	GNDD	–	Table 6 on page 21
91	VCCD	–	Table 3 on page 18
92	RXCLK1	O, TS	Table 3 on page 18
93	RXER1	O, TS	Table 3 on page 18
94	TXER1	I	Table 6 on page 21
95	GNDIO	–	Table 6 on page 21
96	VCCIO	–	Table 3 on page 18
97	TXCLK1	O, TS	Table 3 on page 18
98	TXEN1	I	Table 3 on page 18
99	TXD1_0	I	Table 3 on page 18
100	TXD1_1	I	Table 3 on page 18

1. AI = Analog Input, AO = Analog Output, I = Input, O = Output, OD = Open Drain output, ST = Schmitt Triggered input, TS = Three-State-able output, SL = Slew-rate Limited output, IP = Weak Internal Pull-up, ID = Weak Internal Pull-down.



## 2.0 Signal Descriptions

**Table 2 Port 0 Signal Descriptions (Sheet 1 of 2)**

Pin #	Signal Names	Type <sup>1</sup>	Signal Description
44 43 42 39	TXD0_3 TXD0_2 TXD0_1 TXD0_0	I	<b>Transmit Data.</b> TXD0 <sub>n</sub> is a bundle of parallel data signals driven by the MAC controller, which TXD0<3:0> transition synchronously with respect to the TXCLK0. TXD0<0> is the least significant bit. TXD0<3:0> are monitored in normal mode only.
38	TXEN0	I	<b>Transmit Enable.</b> The MAC asserts TXEN0 when it drives data on TXD0 <sub>n</sub> . This signal must be synchronized to TXCLK0.
36	TXER0	I	<b>Transmit Error.</b> TXER0 is a 100 Mbps only signal. The MAC asserts this input when an error has occurred in the transmit data stream. When operating at 100 Mbps, the LXT973 Transceiver responds by sending "H symbols" on the line.
37	TXCLK0	O, TS	<b>Transmit Clock.</b> TXCLK0 is sourced by the LXT973 Transceiver in both 10 Mbps and 100 Mbps modes. 2.5 MHz for 10 Mbps operation 25 MHz for 100 Mbps operation.
29 30 31 32	RXD0_3 RXD0_2 RXD0_1 RXD0_0	O, TS	<b>Receive Data.</b> The LXT973 Transceiver drives received data on these outputs, synchronous to RXCLK0.
33	RXDV0	O, TS	<b>Receive Data Valid.</b> The LXT973 Transceiver asserts this signal when it drives valid data on RXD0 <sub>n</sub> . This output is synchronous to RXCLK0.
35	RXER0	O, TS	<b>Receive Error.</b> The LXT973 Transceiver asserts this output when it receives invalid symbols from the network. RXER0 is synchronous to RXCLK0.
34	RXCLK0	O, TS	<b>Receive Clock.</b> RXCLK0 is sourced by the LXT973 Transceiver in both 10 Mbps and 100 Mbps modes. 2.5 MHz for 10 Mbps operation 25 MHz for 100 Mbps operation.
45	COL0	O, TS	<b>Collision Detected.</b> The LXT973 Transceiver asserts this output when a collision is detected. This output remains High for the duration of the collision. COL0 is asynchronous and is inactive during full-duplex operation.
46	CRS0	O, TS	<b>Carrier Sense.</b> During half-duplex operation, the LXT973 Transceiver asserts this output when either the transmit or receive medium is non-idle. During full-duplex operation, CRS0 is asserted only when receive medium is non-idle.
1. AI = Analog Input, AO = Analog Output, I = Input, O = Output, OD = Open Drain output, ST = Schmitt Triggered input, TS = Three-State-able output, SL = Slew-rate Limited output, IP = Weak Internal Pull-up, ID = Weak Internal Pull-down.			

**Table 2 Port 0 Signal Descriptions (Sheet 2 of 2)**

Pin #	Signal Names	Type <sup>1</sup>	Signal Description
20	MDDIS0	I	<b>Management Disable.</b> When MDDIS0 is tied High, the MDIO port is completely disabled and the Hardware Control Interface pins set their respective bits at power-up and reset.  When MDDIS0 is pulled Low at power-up or reset via the internal pull-down resistor or by tying it to ground, the Hardware Control Interface Pins control only the initial or "default" values of their respective register bits. After the power-up/reset cycle is complete, bit control reverts to the MDIO serial channel.
26	MDC0	I	<b>Management Data Clock.</b> Clock for MDIO0 serial channel. Maximum frequency is 20 MHz.
25	MDIO0	I/O	<b>Management Data Input/Output.</b> Bi-directional serial data channel for PHY/STA communication.
1. AI = Analog Input, AO = Analog Output, I = Input, O = Output, OD = Open Drain output, ST = Schmitt Triggered input, TS = Three-State-able output, SL = Slew-rate Limited output, IP = Weak Internal Pull-up, ID = Weak Internal Pull-down.			

**Table 3 Port 1 Signal Descriptions (Sheet 1 of 2)**

Pin #	Signal Names	Type <sup>1</sup>	Signal Description
2 1 100 99	TXD1_3 TXD1_2 TXD1_1 TXD1_0	I	<b>Transmit Data.</b> TXD1 <sub>n</sub> is a bundle of parallel data signals driven by the MAC controller. TXD1<3:0> transition synchronously with respect to the TXCLK1. TXD1<0> is the least significant bit. In normal mode, only TXD1<3:0> are monitored.
98	TXEN1	I	<b>Transmit Enable.</b> The MAC asserts TXEN1 when it drives data on TXD0 <sub>n</sub> . This signal must be synchronized to TXCLK1.
94	TXER1	I	<b>Transmit Error.</b> (TXER1 is a 100 Mbps only signal.) The MAC asserts this input when an error has occurred in the transmit data stream. When operating at 100 Mbps, the LXT973 Transceiver responds by sending "H Symbols" on the line.
97	TXCLK1	O, TS	<b>Transmit Clock.</b> TXCLK1 is sourced by the LXT973 Transceiver in both 10 Mbps and 100 Mbps modes. 2.5 MHz for 10 Mbps operation 25 MHz for 100 Mbps operation.
85 86 87 88	RXD1_3 RXD1_2 RXD1_1 RXD1_0	O, TS	<b>Receive Data.</b> The LXT973 Transceiver drives received data on these outputs, synchronous to RXCLK1.
89	RXDV1	O, TS	<b>Receive Data Valid.</b> The LXT973 Transceiver asserts this signal when it drives valid data on RXD0 <sub>n</sub> . This output is synchronous to RXCLK1.
93	RXER1	O, TS	<b>Receive Error.</b> The LXT973 Transceiver asserts this output when it receives invalid symbols from the network. RXER1 is synchronous to RXCLK1.
92	RXCLK1	O, TS	<b>Receive Clock.</b> RXCLK1 is sourced by the LXT973 Transceiver in both 10 Mbps and 100 Mbps modes. 2.5 MHz for 10 Mbps operation 25 MHz for 100 Mbps operation.
1. AI = Analog Input, AO = Analog Output, I = Input, O = Output, OD = Open Drain output, ST = Schmitt Triggered input, TS = Three-State-able output, SL = Slew-rate Limited output, IP = Weak Internal Pull-up, ID = Weak Internal Pull-Down			

**Table 3 Port 1 Signal Descriptions (Sheet 2 of 2)**

Pin #	Signal Names	Type <sup>1</sup>	Signal Description
3	COL1	O, S	<b>Collision Detected.</b> The LXT973 Transceiver asserts this output when a collision is detected. This output remains High for the duration of the collision. COL is asynchronous and is inactive during full-duplex operation.
4	CRS1	O, S	<b>Carrier Sense.</b> During half-duplex operation, the LXT973 Transceiver asserts this output when either the transmit or receive medium is non-idle. During full-duplex operation, CRS1 is asserted only when receive medium is non-idle.
19	MDDIS1	I	<b>Management Disable.</b> When MDDIS is tied High, the MDIO port is completely disabled and the Hardware Control Interface pins set their respective bits at power-up and reset.  When MDDIS is pulled Low at power-up or reset via the internal pull-down resistor or by tying it to ground, the Hardware Control Interface Pins control only the initial or “default” values of their respective register bits. After the power-up/reset cycle is complete, bit control reverts to the MDIO serial channel.
22	MDC1	I	<b>Management Data Clock.</b> Clock for MDIO1 serial channel. Maximum frequency is 20 MHz. <b>(Note:</b> 20 MHz value to be verified prior to final production release of product.)
23	MDIO1	I/O	<b>Management Data Input/Output.</b> Bidirectional serial data channel for PHY/STA communication.
1. AI = Analog Input, AO = Analog Output, I = Input, O = Output, OD = Open Drain output, ST = Schmitt Triggered input, TS = Three-State-able output, SL = Slew-rate Limited output, IP = Weak Internal Pull-up, ID = Weak Internal Pull-Down			

**Table 4 Network Interface Signal Descriptions (Sheet 1 of 2)**

Pin #	Signal Names	TP Op	Fiber Op	Port	Pair Type	Type <sup>1</sup>	Signal Description
59 60	DPAP_0 DPAN_0	TX+ TX-	RX+ RX-	0 0	A A	AI/AO, SL	<b>Twisted-Pair/Fiber Pair A, Positive &amp; Negative - Port 0.</b> Differential pair produces or receives IEEE 802.3-compliant pulses for either 100BASE-TX or 10BASE-T.  Also acts as receiver in Fiber mode.
63 64	DPBP_0 DPBN_0	RX+ RX-	TX+ TX-	0 0	B B	AI/AO, SL	<b>Twisted-Pair/Fiber Pair B, Positive &amp; Negative - Port 0.</b> Differential pair produces or receives IEEE 802.3-compliant pulses for either 100BASE-TX or 10BASE-T.  Also acts as transmitter in Fiber mode.
76	SD0	-	-	-	-	I	<b>Signal Detect.</b> This signal is used for signal quality indication in Fiber mode. In twisted-pair mode, this pin should be tied to GND.
1. AI = Analog Input, AO = Analog Output, I = Input, O = Output, OD = Open Drain output, ST = Schmitt Triggered input, TS = Three-State-able output, SL = Slew-rate Limited output, IP = Weak Internal Pull-up, ID = Weak Internal Pull-Down							

**Table 4 Network Interface Signal Descriptions (Sheet 2 of 2)**

Pin #	Signal Names	TP Op	Fiber Op	Port	Pair Type	Type <sup>1</sup>	Signal Description
67 68	DPBP_1 DPBN_1	TX+ TX-	TX- TX+	1 1	B B	AI/AO, SL	<b>Twisted-Pair/Fiber Pair B, Positive &amp; Negative - Port 1.</b> Differential pair produces or receives IEEE 802.3-compliant pulses for either 100BASE-TX or 10BASE-T. Also acts as transmitter in Fiber mode.
71 72	DPAP_1 DPAN_1	RX+ RX-	RX- RX+	1 1	A A	AI/AO, SL	<b>Twisted-Pair/Fiber Pair A, Positive &amp; Negative - Port 1.</b> Differential pair produces or receives IEEE 802.3-compliant pulses for either 100BASE-TX or 10BASE-T. Also acts as receiver in Fiber mode.
75	SD1	-	-	-	-	I	<b>Signal Detect.</b> This signal is used for signal quality indication in Fiber mode. In twisted-pair mode, this pin should be tied to GND.
1. AI = Analog Input, AO = Analog Output, I = Input, O = Output, OD = Open Drain output, ST = Schmitt Triggered input, TS = Three-State-able output, SL = Slew-rate Limited output, IP = Weak Internal Pull-up, ID = Weak Internal Pull-Down							

**Table 5 Global Control & Configuration Signal Descriptions**

Pin #	Signal Names	Type <sup>1</sup>	Signal Description																									
78 79	TxSLEW0 TxSLEW1	I	<b>Tx Output Slew Controls 0 &amp; 1.</b> These pins select the TX output slew rate (rise and fall time) for both cores in the LXT973 Transceiver. The various options are defined in Register bits 27.11:10. The TxSLEW pins set the power-on value of these register bits.																									
13	RESET	I	<b>Reset.</b> This active Low input is OR'd with Control Register bit 0.15.																									
52 53 54 55	ADDR4 ADDR3 ADDR2 ADDR1	I	<b>Address &lt;4:1&gt;.</b> Sets device Port 0 PHY address. Note that ADDR0 is set internally so that Port 1 is always "1" address higher than Port 0.																									
56 57	TEST_0 TEST_1	I	<b>Test Pins.</b> Tie Low for normal operation.																									
15	REFCLK	I	<b>Master Clock Input.</b> A 25 MHz, 50 ppm clock is input here to act as the master clock. Full clock requirements are detailed in the Clock Requirements section of the Functional Description. See <a href="#">Section 3.4.2, Clock Requirements, on page 30</a> .																									
11 12	LED_CFG0 LED_CFG1	I	<b>LED Configuration 0 &amp; 1.</b> These pins are used to select one of four LED modes. The decode or each mode is shown below: <table border="1" style="width: 100%; border-collapse: collapse;"> <thead> <tr> <th>LED_CFG0</th> <th>LED_CFG1</th> <th>LEDn_1</th> <th>LEDn_2</th> <th>LEDn_3</th> </tr> </thead> <tbody> <tr> <td>0</td> <td>0</td> <td>Speed</td> <td>Link</td> <td>Duplex</td> </tr> <tr> <td>1</td> <td>0</td> <td>Speed</td> <td>Link/Activity</td> <td>Duplex/Collision</td> </tr> <tr> <td>0</td> <td>1</td> <td>Link</td> <td>Receive</td> <td>Transmit</td> </tr> <tr> <td>1</td> <td>1</td> <td>Speed</td> <td>Link/MII Isolate</td> <td>Duplex/Collision</td> </tr> </tbody> </table>	LED_CFG0	LED_CFG1	LEDn_1	LEDn_2	LEDn_3	0	0	Speed	Link	Duplex	1	0	Speed	Link/Activity	Duplex/Collision	0	1	Link	Receive	Transmit	1	1	Speed	Link/MII Isolate	Duplex/Collision
LED_CFG0	LED_CFG1	LEDn_1	LEDn_2	LEDn_3																								
0	0	Speed	Link	Duplex																								
1	0	Speed	Link/Activity	Duplex/Collision																								
0	1	Link	Receive	Transmit																								
1	1	Speed	Link/MII Isolate	Duplex/Collision																								
1. AI = Analog Input, AO = Analog Output, I = Input, O = Output, OD = Open Drain output, ST = Schmitt Triggered input, TS = Three-State-able output, SL = Slew-rate Limited output, IP = Weak Internal Pull-up, ID = Weak Internal Pull-Down																												

**Table 6 Power Supply Signal Descriptions**

Pin #	Signal Names	Type <sup>1</sup>	Signal Description
40, 91	VCCD	–	<b>Digital Power Supply - Core.</b> +2.5 V supply for core digital circuits.
27, 47, 84, 96	VCCIO	–	<b>Digital Power Supply - I/O Ring.</b> +2.5/3.3 V supply for digital I/O circuits. The digital input circuits running off this rail, having a TTL-level threshold and over-voltage protection, may be interfaced with 3.3/5.0V when the I/O supply is 3.3 V, and 2.5/3.3/5.0V when the I/O supply is 2.5 V.
74	VCCPECL	–	<b>Digital Power Supply - PECL Signal Detect Inputs.</b> +2.5/3.3 V supply for PECL Signal Detect input circuits. If Fiber Mode is not used, tie these pins to GNDPECL to save power.
58, 73	VCCR	–	<b>Analog Power Supply - Receive.</b> +2.5 V supply for all analog receive circuits.
65, 66	VCCT	–	<b>Analog Power Supply - Transmit.</b> +2.5 V supply for all analog transmit circuits.
16, 41, 90,	GNDD	–	<b>Digital Ground.</b> Ground return for core digital supplies (VCCD). All ground pins can be tied together using a single ground plane.
28, 48, 83, 95	GNDIO	–	<b>Digital GND - I/O Ring.</b> Ground return for digital I/O circuits (VCCIO).
77	GNDPECL	–	<b>Digital GND - PECL Signal Detect Inputs.</b> Ground return for PECL Signal Detect input circuits.
69, 62	GNDR	–	<b>Analog Ground - Receive.</b> Ground return for receive analog supply. All ground pins can be tied together using a single ground plane.
61, 70	GNDT	–	<b>Analog Ground - Transmit.</b> Ground return for transmit analog supply. All ground pins can be tied together using a single ground plane.
14	SGND	–	<b>Substrate Ground.</b> Ground for chip substrate. All ground pins can be tied together using a single ground plane.
1. AI = Analog Input, AO = Analog Output, I = Input, O = Output, OD = Open Drain output, ST = Schmitt Triggered input, TS = Three-State-able output, SL = Slew-rate Limited output, IP = Weak Internal Pull-up, ID = Weak Internal Pull-Down			

**Table 7 Per Port LED and Configuration Signal Descriptions (Sheet 1 of 2)**

Pin #	Signal Names	Type <sup>1</sup>	Signal Description
49 50 51	LED0_1 LED0_2 LED0_3	OD, TS, SL, IP	<b>Port 0 LED Drivers 1-3.</b> These pins drive LED indicators for Port 0. Each LED can display one of several available status conditions as selected by the LED Configuration Register.
82 81 80	LED1_1 LED1_2 LED1_3	OD, TS, SL, IP	<b>Port 1 LED Drivers 1-3.</b> These pins drive LED indicators for Port 1. Each LED can display one of several available status conditions as selected by the LED Configuration Register.
6 5	AUTO_NEG0 AUTO_NEG1	I I	<b>Auto Negotiation Enable.</b> When this pin is High, auto-negotiation is enabled on the relevant port.
1. AI = Analog Input, AO = Analog Output, I = Input, O = Output, OD = Open Drain output, ST = Schmitt Triggered input, TS = Three-State-able output, SL = Slew-rate Limited output, IP = Weak Internal Pull-up, ID = Weak Internal Pull-Down			

**Table 7 Per Port LED and Configuration Signal Descriptions (Sheet 2 of 2)**

Pin #	Signal Names	Type <sup>1</sup>	Signal Description
8	SD_2P5V/ SPEED0	I	<b>SD_2P5V.</b> In fiber mode, this pin selects between 2.5 V or 3.3 V fiber transceiver thresholds for both ports. High = 2.5 V Low = 3.3 V <b>Speed.</b> In copper mode, this pin sets the default speed of Port 0 in Hardware mode. High = 100 Mbps Low = 10 Mbps
7	SD_2P5V/ SPEED1	I	<b>SD_2P5V.</b> In fiber mode, the speed of both ports defaults to 100BASE-FX. Pin 7 should be tied to ground. <b>Speed.</b> In copper mode, this pin sets the default speed of Port 1 in Hardware mode. High = 100 Mbps Low = 10 Mbps
10 9	DUPLEX0 DUPLEX1	I I	<b>Duplex.</b> Sets the duplex setting of the port in Hardware mode. High is full-duplex and Low is half-duplex.
18 17	FIBER_TP0 FIBER_TP1	I I	<b>Fiber/Twisted-Pair.</b> Sets the operating state of the port in Hardware mode. High is twisted-pair and Low is fiber.
24 21	PWRDWN0 PWRDWN1	I I	<b>Power-Down.</b> When set High, this pin puts the relevant PHY into power-down mode.
1. AI = Analog Input, AO = Analog Output, I = Input, O = Output, OD = Open Drain output, ST = Schmitt Triggered input, TS = Three-State-able output, SL = Slew-rate Limited output, IP = Weak Internal Pull-up, ID = Weak Internal Pull-Down			

---

## 3.0 Functional Description

### 3.1 Introduction

The Cortina Systems® LXT973 10/100 Mbps Dual-Port Fast Ethernet PHY Transceiver (LXT973 Transceiver) is an IEEE-compliant, dual-port, Fast Ethernet PHY transceiver that directly supports both 100BASE-TX and 10BASE-T applications. The device incorporates full Media Independent Interface (MII), enabling each individual network port to connect with 10/100 Mbps MACs. Each port directly drives either a 100BASE-TX line or a 10BASE-T line (up to 160 meters). The LXT973 Transceiver also supports 100BASE-FX operation via an LVPECL interface. The device uses a 100-pin QFP package.

#### 3.1.1 Comprehensive Functionality

The LXT973 Transceiver performs all functions of the Physical Coding Sublayer (PCS) and Physical Media Attachment (PMA) sublayer as defined in the IEEE 802.3 100BASE-X specification. This device also performs all functions of the Physical Media Dependent (PMD) sublayer for 100BASE-TX connections.

On power-up, the LXT973 Transceiver reads its configuration inputs to check for forced operation settings. If not configured for forced operation, each port uses auto-negotiation/parallel detection to automatically determine line operating conditions. If the link partner supports auto-negotiation, the LXT973 Transceiver auto-negotiates with it using Fast Link Pulse (FLP) Bursts. If the PHY partner does not support auto-negotiation, the LXT973 Transceiver automatically detects (parallel detection) the presence of either link pulses (10 Mbps PHY) or IDLE symbols (100 Mbps PHY) and sets its operating conditions accordingly. When parallel detection is used to establish link, the resulting link is at half-duplex. The LXT973 Transceiver provides half-duplex and full-duplex operation at 100 Mbps and 10 Mbps.

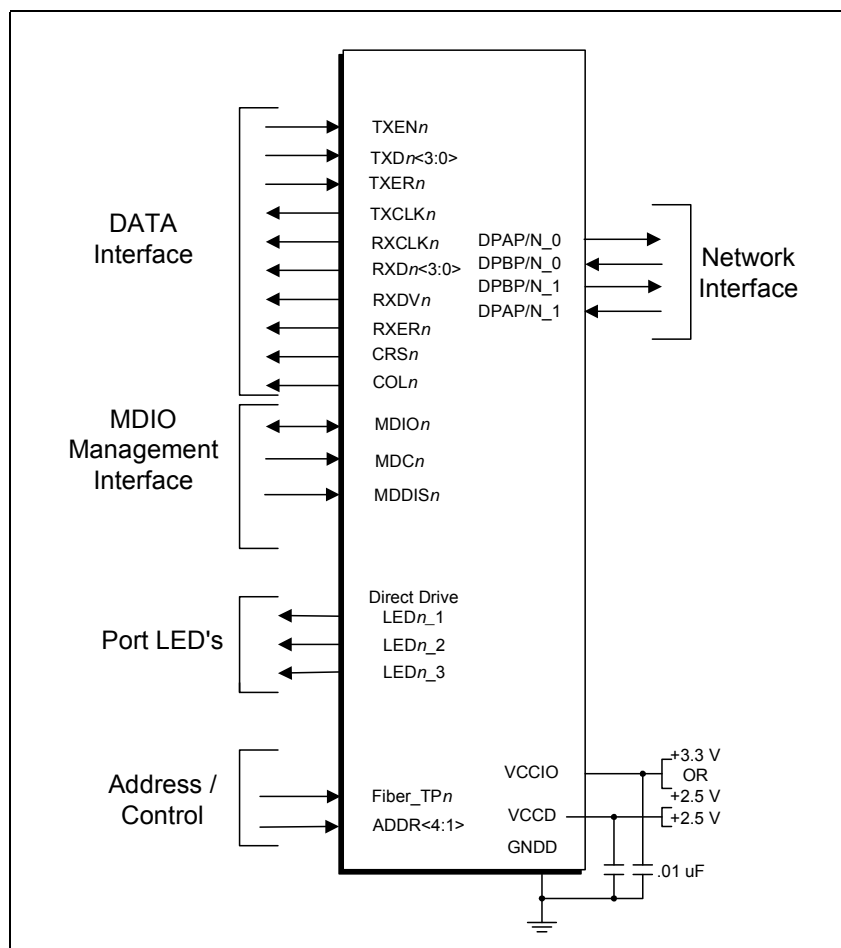
### 3.2 Interface Descriptions

#### 3.2.1 10/100 Mbps Network Interface

The LXT973 Transceiver supports both 10BASE-T and 100BASE-TX Ethernet over twisted-pair, or 100 Mbps Ethernet over fiber media (100BASE-FX). Each network interface port consists of four external pins (two differential signal pairs). The pins are shared between twisted-pair and fiber.

The LXT973 Transceiver output drivers generate either 100BASE-TX, 10BASE-T, or 100BASE-FX output. When not transmitting data, the device generates IEEE 802.3-compliant link pulses or IDLE code. Input signals are decoded either as a 100BASE-TX, 100BASE-FX, or 10BASE-T input, depending on the mode selected. Auto-negotiation/parallel detection or manual control is used to determine the speed of this interface. Polarity is determined by the MDI crossover function.

**Figure 3 Interfaces**



### 3.2.1.1 Twisted-Pair Interface

The LXT973 Transceiver supports either 100BASE-TX or 10BASE-T connections over 100Ω, Category 5, Unshielded Twisted-Pair (UTP). Only a transformer, RJ-45, and bypass capacitors are required to complete this interface. The transmitter shapes the outgoing signal to help reduce the need for external EMI filters. Four slew rate settings allow the designer to match the output waveform to the magnetic characteristics. Both transmit and receive terminations are built into the LXT973 Transceiver. Therefore, no external components are required between the LXT973 Transceiver and the external transformer. The transmitter uses a transformer with a center tap to help reduce power consumption.

When operating at 100 Mbps, MLT3 symbols are continuously transmitted and received. When not transmitting data, the LXT973 Transceiver generates "IDLE" symbols.

During 10 Mbps operation, LXT973 Transceiver encoded data is exchanged. When no data is exchanged, the line transmits normal link pulses to maintain link.



### 3.2.1.2 MDI Crossover (MDIX)

The LXT973 Transceiver crossover function, which is compliant to the IEEE 802.3, clause 23 standard, connects the transmit output of the device to the far-end receiver in a link segment. This function can be configured via Register bits 27.9:8. Please refer to [Section 7.0, Auto-MDI/MDIX, on page 56](#). Default mode is auto-MDIX enabled.

### 3.2.1.3 Fiber Interface

The LXT973 Transceiver fiber ports are designed to interface with common industry-standard 3.3 V and 5 V fiber-optic transceivers. Each port incorporates a Low Voltage PECL interface that complies with the ANSI X3.166 standard for seamless integration.

Fiber mode is selected through Register bit 16.0 by the following two methods:

1. Configure Register bit 16.0 = 1 on a per-port basis by driving the Hardware Control pin FIBER\_TP $n$  (on the respective port) to a logic Low value on power-up and/or reset.
2. Configure Register bit 16.0 = 1 on a per-port basis through the MDIO interface.

## 3.3 MII Operation

The LXT973 Transceiver implements the Media Independent Interface (MII) as defined in the IEEE 802.3 standard. Separate channels are provided for transmitting data from the MAC to the LXT973 Transceiver (TXD), and for passing data received from the line (RXD) to the MAC. Each channel has its own clock, data bus, and control signals. Nine signals are used to pass received data to the MAC: RXD<3:0>, RXCLK, RXDV, RXER, COL and CRS. Seven signals are used to transmit data from the MAC: TXD<3:0>, TXCLK, TXEN, and TXER.

The LXT973 Transceiver supplies both clock signals as well as separate outputs for carrier sense and collision. Data transmission across the MII is normally implemented in 4-bit-wide nibbles.

### 3.3.1 MII Clocks

The LXT973 Transceiver is the master clock source for data transmission and supplies both MII clocks (RXCLK and TXCLK). It automatically sets the clock speeds to match link conditions. When the link is operating at 100 Mbps, the clocks are set to 25 MHz. When the link is operating at 10 Mbps, the clocks are set to 2.5 MHz. The transmit data and control signals must always be synchronized to TXCLK by the MAC. The LXT973 Transceiver samples these signals on the rising edge of TXCLK.

### 3.3.2 Transmit Enable

The MAC must assert TXEN at the same time as the first nibble of preamble, and deassert TXEN after the last bit of the packet.

### 3.3.3 Receive Data Valid

The LXT973 Transceiver asserts RXDV when it receives a valid packet. Timing changes depend on line operating speed:

- For 100BASE-TX links, RXDV is asserted from the first nibble of preamble to the last nibble of the data packet.

- For 10BASE-T links, the entire preamble is truncated. RXDV is asserted with the first nibble of the Start-of-Frame Delimiter (SFD) “5D” and remains asserted until the end of the packet.

### 3.3.4 Carrier Sense

Carrier Sense (CRS) is an asynchronous output. CRS is generated when a packet is received from the line regardless of duplex mode, and for a transmission to the line in half-duplex mode. [Table 8 on page 27](#) summarizes the conditions for assertion of carrier sense, collision, and data loopback signals. Carrier sense is not generated when a packet is transmitted in full-duplex mode.

For 100BASE-TX and 100BASE-FX links, a Start-of-Stream Delimiter (SSD) or /J/K/ symbol pair causes assertion of carrier sense (CRS). An End-of-Stream Delimiter (ESD), or /T/R/ symbol pair causes de-assertion of CRS. The PMA layer also de-asserts CRS if IDLE symbols are received without /T/R/. In this event, the RXER bit in the RX Status Frame is asserted for one clock cycle when CRS is de-asserted.

For 10BASE-T links, CRS assertion is based on receipt of a valid preamble, and de-assertion is based on receipt of an End-of-Frame (EOF) marker.

### 3.3.5 Error Signals

When the LXT973 Transceiver is in 100 Mbps mode and receives an invalid symbol from the network, it asserts RXER and drives “1110” on the RXD pins.

When the MAC asserts TXER, the LXT973 Transceiver drives “H” symbols out on the DPAP/N\_0 or DPAP/N\_1 pins.

### 3.3.6 Collision

The LXT973 Transceiver asserts its collision signal, asynchronously to any clock, when the line state is half-duplex and the transmitter and receiver are active at the same time. [Table 8 on page 27](#) summarizes the conditions for assertion of carrier sense, collision, and data loopback signals.

### 3.3.7 Loopback

The LXT973 Transceiver provides two loopback functions, operational and test (see [Table 8 on page 27](#)). Loopback paths are shown in [Figure 4 on page 27](#).

#### 3.3.7.1 Operational Loopback

Operational loopback is provided for 10 Mbps half-duplex links when Register bit 16.8 = 0. Data transmitted by the MAC (TXD) is looped back on the receive side of the MII (RXD). Operational loopback is not provided for 100 Mbps links, full-duplex links, or when Register bit 16.8 = 1.

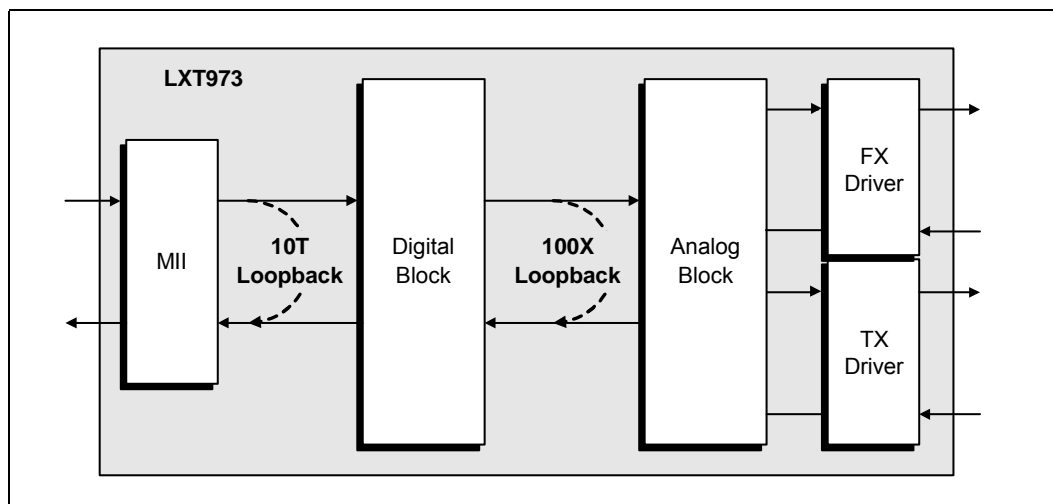
#### 3.3.7.2 Test Loopback

A test loopback function is provided for diagnostic testing of the LXT973 Transceiver. During test loopback, twisted-pair and fiber interfaces are disabled. Data transmitted by the MAC is internally looped back by the LXT973 Transceiver and returned to the MAC (see [Figure 4](#)).

Test loopback is available for both 100BASE-TX and 10BASE-T operation and is enabled by setting the following register bits:

- Register bit 0.14 = 1 (loopback mode)
- Register bit 0.8 = 1 (full-duplex)
- Register bit 0.12 = 0 (disable auto-negotiation).

**Figure 4 Loopback Paths**



**Table 8 Carrier Sense, Loopback, and Collision Conditions**

Speed	Duplex Condition	Carrier Sense	Test Loopback <sup>1</sup>	Operational Loopback	Collision
100 Mbps	Full-Duplex	Receive Only	Yes	No	None
	Full-Duplex	Receive Only	No	No	None
	Half-Duplex	Transmit or Receive	No	No	Transmit and Receive
10 Mbps	Full-Duplex	Receive Only	Yes	No	None
	Full-Duplex	Receive Only	No	No	None
	Half-Duplex, Register bit 16.8 = 0	Transmit or Receive	Yes	Yes	Transmit and Receive
	Half-Duplex, Register bit 16.8 = 1	Transmit or Receive	No	No	Transmit and Receive

1. Test loopback is enabled when Register bit 0.14 = 1, Register bit 0.8 = 1, and Register bit 0.12 = 0.

### 3.3.8 Configuration Management Interface

The LXT973 Transceiver provides an MDIO Management Interface and a Hardware Control Interface for device configuration and management.

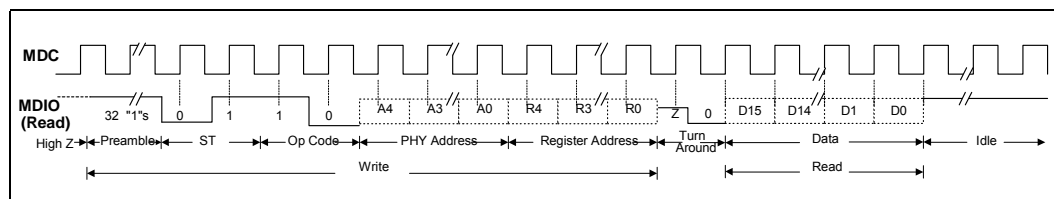
### 3.3.8.1 MII Management Interface

The LXT973 Transceiver supports the IEEE 802.3 MII Management Interface also known as the Management Data Input/Output (MDIO) Interface. This interface allows upper-layer devices to monitor and control the state of the LXT973 Transceiver. The MDIO interface consists of a physical connection, a specific protocol which runs across the connection, and an internal set of addressable registers. The physical interface consists of a data line (MDIO) and clock line (MDC), and a control line (MDDIS). The maximum speed of MDC is 20 MHz.

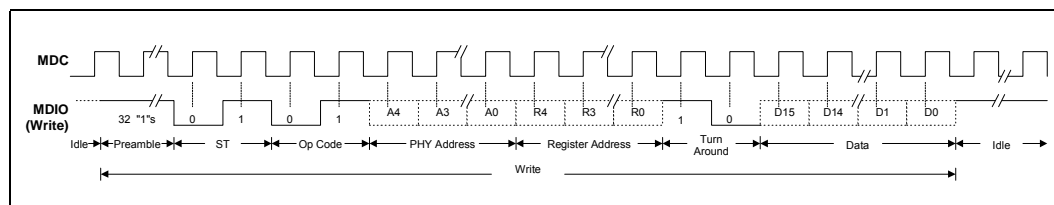
Operation of this interface is controlled by the MDDIS<sub>n</sub> input pin. When MDDIS<sub>n</sub> is High, the MDIO is completely disabled. When MDDIS<sub>n</sub> is Low, read and write are enabled. The timing for the MDIO Interface is shown in Table 49 on page 89. See Figure 5 for read operations, and Figure 6 for write operations. The protocol allows one controller to communicate with multiple LXT973 Transceiver devices. Each LXT973 Transceiver port is assigned an address between 0 and 31, as described in Table 5 on page 20 (ADDR<4:1>).

The LXT973 Transceiver supports the core 16-bit MDIO registers. Registers 0-10 and 15 are required and their functions are specified by the IEEE 802.3 specification. Additional registers are included for expanded functionality. Specific bits in the registers are referenced using an “X.Y” notation, where X is the register number (0-31) and Y is the bit number (0-15)

**Figure 5 Management Interface Read Frame Structure**



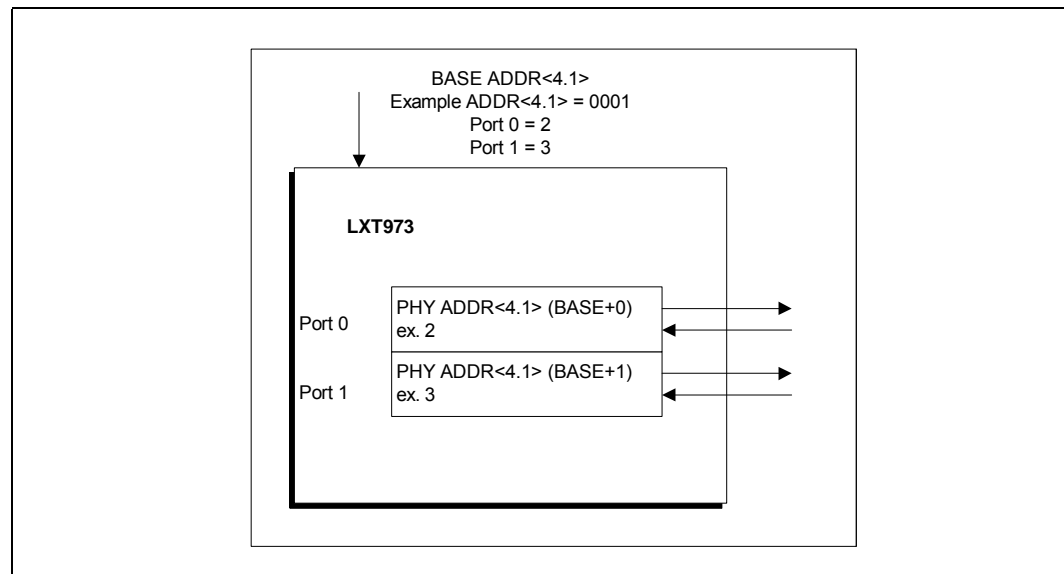
**Figure 6 Management Interface Write Frame Structure**



### 3.3.8.2 MII Addressing

The MDIO management protocol allows one controller to communicate with multiple LXT973 Transceiver chips. Pins ADDR\_<4:1> determine the base address. Each port adds its port number to the base address to obtain its port address as shown in [Figure 7](#) on page 29.

**Figure 7** Port Address Scheme



### 3.3.8.3 Hardware Control Interface

The LXT973 Transceiver provides a Hardware Control Interface for applications where the MDIO is not desired. Refer to [Figure 18, Initialization Sequence, on page 52](#) for additional details.

## 3.4 Operating Requirements

### 3.4.1 Power Requirements

The LXT973 Transceiver requires five power supply inputs: VCCD, VCCR, VCCT, VCCPECL, and VCCIO. The digital and analog circuits require 2.5 V supplies (VCCD, VCCR, and VCCT). These inputs may be supplied from a single source although decoupling is required to each respective ground. The fiber VCCPECL supply can be connected to either 2.5 V or 3.3 V.

A separate power supply may be used for MII and MDIO (VCCIO) interfaces. The power supply may be either +2.5 V or +3.3 V. VCCIO should be supplied from the same power source used to supply the controller on the other side of the interface. As a matter of good practice, these supplies should be as clean as possible.

---

## 3.4.2 Clock Requirements

### 3.4.2.1 Reference Clock / External Oscillator

The LXT973 Transceiver requires a constant enabled reference clock (REFCLK). REFCLK frequency must be 25 MHz. Considering overall system performance first, the clock is best derived by providing a crystal-based oscillator. PLL-based oscillators with known stability may also be used. In general, an oscillator-based clock source is recommended over a derived clock due to frequency stability and overall signal integrity. Regardless of clock source, careful consideration should be given to physical placement, board layout, and signal routing of the source to maintain the highest possible level of signal integrity. Refer to [Table 33 on page 78](#) for clock timing requirements.

### 3.4.2.2 MDIO Clock

The MII management channel (MDIO) also requires an external clock. The managed data clock (MDC) speed is a maximum of 20 MHz. Refer to [Table 49 on page 89](#) for details.

## 3.5 Initialization

When the LXT973 Transceiver is first powered on, reset, or encounters a link failure state, it checks the MDIO register configuration bits to determine the line speed and operating conditions to use for the network link. The configuration bits may be set by the Hardware Control or MDIO interface as shown in [Table 9 on page 32](#).

### 3.5.1 MDIO Control Mode

In the MDIO Control mode, the LXT973 Transceiver reads the Hardware Control Interface pins to set the initial (default) values of the MDIO registers. Once the initial values are set, bit control reverts to the MDIO interface.

### 3.5.2 Hardware Control Mode

In the Hardware Control Mode, the LXT973 Transceiver disables direct write operations to the MDIO registers via the MDIO interface. On power-up or hardware reset the LXT973 Transceiver reads the Hardware Control Interface pins and sets the MDIO registers accordingly.

The following modes are available using either Hardware Control or MDIO Control:

- Forced network link to 100BASE-FX (Fiber)
- Forced network link operation to:
  - 100BASE-TX, full-duplex
  - 100BASE-TX, half-duplex
  - 10BASE-T, full-duplex
  - 10BASE-T, half-duplex
- Allow auto-negotiation/parallel-detection

When the network link is forced to a specific configuration, the LXT973 Transceiver immediately begins operating the network interface as commanded. When auto-negotiation is enabled, the LXT973 Transceiver begins the auto-negotiation/parallel-detection operation.

### 3.5.3 Power-Down Mode

The LXT973 Transceiver incorporates numerous features to maintain the lowest power possible. The device can be put into a low-power state via Register 0 as well as a near-zero power state with the power-down pins. When in power-down mode, the device is not capable of receiving or transmitting packets.

The lowest power operation is achieved using the global power-down pins. These active High pins power down every circuit in the device, including the clocks. All registers are unaltered and maintained. When the power-down pins are released, the registers are reloaded with the value of the last hardware reset.

Individual ports (software power-down) can be powered down using Control Register bit 0.11. This bit powers down a significant portion of the port, but clocks to the register section remain active. This allows the management interface to remain active during register power-down. The power-down bit is active High.

#### 3.5.3.1 Hardware Power-Down

The hardware power-down per port mode is controlled by the PWRDWN 0/1 pins. When PWRDWN 0/1 is High, the following conditions are true:

- LXT973 Transceiver ports and the clock are shut down.
- Outputs are three-stated.
- The MDIO registers are not accessible.
- Configuration pins are not read upon release of the PWRDWN 0/1 pins, and registers are reloaded with the value of the last hardware reset.

#### 3.5.3.2 Software Power-Down

Software port power-down control is provided by Register bit 0.11 in the respective port Control Registers (refer to [Table 16 on page 66](#)). During individual port power-down, the following conditions are true:

- The individual port is shut down.
- The MDIO registers remain accessible.
- The register remains unchanged.

### 3.5.4 Reset

The LXT973 Transceiver provides both hardware and software resets. Configuration control of auto-negotiation, speed, and duplex mode selection is handled differently for each. During a hardware reset, settings for Register bits 0.13, 0.12, and 0.8 are read in from the pins (refer to [Table 9 on page 32](#) for pin settings and [Table 16 on page 66](#) for register bit definitions).

During a software reset (Register bit 0.15 = 1), the bit settings are not re-read from the pins, and revert back to the values that were read in during the last hardware reset. Any changes to pin values from the last hardware reset are not detected during a software reset. Also, during a software reset (Register bit 0.15 = 1), the registers are available for reading. The reset bit is polled to see when the part has completed reset (Register bit 0.15 = 0).

During a hardware reset, register information is unavailable for 1 ms after de-assertion of the reset. All the MII interface pins are disabled during a hardware reset and released to the bus on de-assertion of reset.

### 3.5.5 Hardware Configuration Settings

The LXT973 Transceiver provides a hardware option to set the initial device configuration. The hardware option uses four per-port configuration pins that provide control (see [Table 9 on page 32](#)).

**Table 9 Configuration Settings (Hardware Control Interface)**

FIBER/ TP <sub>x</sub>	AUTO-NEG <sub>x</sub>	SPEED <sub>x</sub>	DUPLEX <sub>x</sub>	Mode
Low	-	-	Low	100BASE-FX is enabled in half-duplex mode. Auto-negotiation is disabled.
Low	-	-	High	100BASE-FX is enabled in full-duplex mode. Auto-negotiation is disabled.
High	High	High	High	AUTO_NEG is enabled. All capabilities are advertised. Register bits 4.8:5 are set to 1.
High	High	High	Low	AUTO_NEG is enabled. Only 100 Mbps capabilities are advertised. Register bits 4.8:7 are set to 1. Register bits 4.6:5 are cleared to 0.
High	High	Low	High	AUTO_NEG is enabled. Only 10 Mbps capability is advertised. Register bits 4.8:7 are cleared to 0. Register bits 4.6:5 are set to 1.
High	High	Low	Low	AUTO_NEG is enabled. Only half-duplex capability is advertised. Register bits 4.7 and 4.5 are set to 1. Register bits 4.8 and 4.6 are cleared to 0.
High	Low	High	High	AUTO_NEG is disabled. LXT973 Transceiver port x is forced to 100 Mbps full-duplex operation.
High	Low	High	Low	AUTO_NEG is disabled. LXT973 Transceiver port x is forced to 100 Mbps half-duplex operation.
High	Low	Low	High	AUTO_NEG is disabled. LXT973 Transceiver port x is forced to 10 Mbps full-duplex operation.
High	Low	Low	Low	AUTO_NEG is disabled. LXT973 Transceiver port x is forced to 10 Mbps half-duplex operation.

1. These pins also set the default values for Registers 0 and 4 accordingly.



---

## 3.6 Link Establishment

### 3.6.1 Auto-Negotiation

The LXT973 Transceiver attempts to auto-negotiate with its link partner by sending Fast Link Pulse (FLP) bursts. Each burst consists of 33 pulse positions spaced 62.5  $\mu$ s apart. Odd link pulses (clock pulses) are always present. Even link pulses (data pulses) may also be present or absent to indicate a “1” or a “0”. Each FLP burst exchanges 16 bits of data, referred to as a “page.” All devices that support auto-negotiation must implement the “Base Page”, defined by IEEE 802.3 (Registers 4 and 5). The LXT973 Transceiver also supports the optional “Next Page” function (Registers 7 and 8).

#### 3.6.1.1 Base Page Exchange

By exchanging Base Pages, the LXT973 Transceiver and its link partner communicate their capabilities to each other. Both sides must receive at least three identical base pages for negotiation to proceed. Each side finds their highest common capabilities, exchange more pages, and agree on the operating state of the line.

#### 3.6.1.2 Next Page Exchange

Additional information, exceeding that required by Base Page exchange, can also be sent via “Next Pages.” The LXT973 Transceiver fully supports the IEEE 802.3 method of negotiation via Next Page exchange. The Next Page exchange uses Register 7 to send information and Register 8 to receive information, and occurs only if both ends of the link advertise their ability to exchange Next Pages. The LXT973 Transceiver is configured to make Next Page exchange easier for software. When a Base Page or Next Page is received, the Page Received Register bit 6.1 remains set until read. When Register bit 6.2 (Next Page Able) is received, it stays set until read. This bit should be cleared whenever a new negotiation occurs. This prevents the user from reading an old value in Register 6 and assuming there is valid information in Registers 5 and 8. Additionally, Register 6 contains a new bit (Register bit 6.5) that indicates when the current Received Page is the Base Page. This information is useful for recognizing when next pages must be re-sent due to the start of a new negotiation process. Register bit 16.1 and the Page Received bit (Register bit 6.1) are also cleared upon reading Register 6.

#### 3.6.1.3 Controlling Auto-Negotiation

When auto-negotiation is controlled by software, the following steps are recommended:

3. After power-up, power-down, or reset, the power-down recovery time (max = 300  $\mu$ s) must be exhausted before proceeding.
4. Set the auto-negotiation advertisement register bits.
5. Enable auto-negotiation (set MDIO Register bit 0.12 = 1).

#### 3.6.1.4 Link Criteria

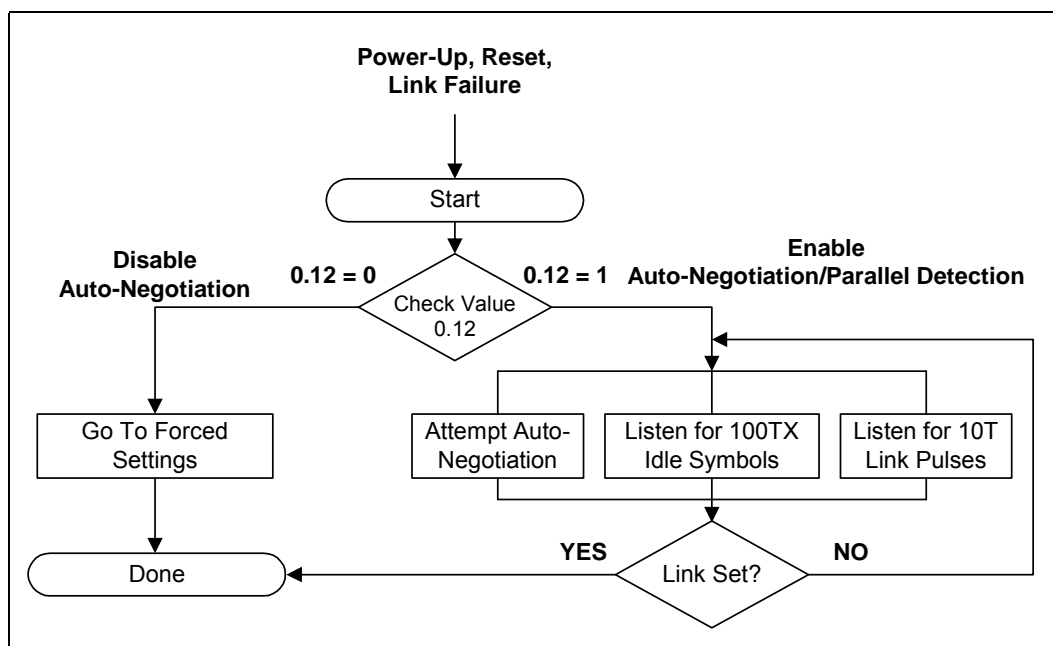
In 100 Mbps mode, link is established when the scrambler becomes locked and remains locked for approximately 50 ms. Link remains up unless the de-scrambler receives less than 12 consecutive IDLE symbols in any 2 ms period. This provides a very robust operation, filtering out any small noise hits that may disrupt the link.

In 10 Mbps mode, link is established based on the link state machine found in the IEEE 802.3, Clause 14.X specification. Receiving 100 Mbps idle patterns does not bring up a 10 Mbps link.

### 3.6.1.5 Parallel Detection

In parallel with auto-negotiation, the LXT973 Transceiver also monitors for 10 Mbps Normal Link Pulses (NLP) or 100 Mbps IDLE symbols. If either is detected, the device automatically reverts to the corresponding operating mode. Parallel detection allows the LXT973 Transceiver to communicate with devices that do not support auto-negotiation. The established link is always set at half-duplex.

**Figure 8 Auto-Negotiation Operation**



## 3.7 Network Media/Protocol Support

The LXT973 Transceiver supports both 10BASE-T and 100BASE-TX Ethernet over twisted-pair, or 100 Mbps Ethernet over fiber media (100BASE-FX).

### 3.7.1 10/100 Mbps Network Interface

The network interface port consists of five external pins (two differential signal pairs and a signal detect pin). The differential signal pins are shared between twisted-pair and fiber. Refer to [Figure 3 on page 24](#) for specific pin assignments.

The LXT973 Transceiver output drivers generate either 100BASE-TX, 10BASE-T, or 100BASE-FX output. When not transmitting data, the LXT973 Transceiver generates IEEE 802.3-compliant link pulses or an IDLE code. Input signals are decoded either as a 100BASE-TX, 100BASE-FX, or 10BASE-T input, depending on the mode selected. Auto-negotiation/parallel detection or manual control is used to determine the speed of this interface.

---

### 3.7.2 Twisted-Pair Interface

When operating at 100 Mbps, the LXT973 Transceiver continuously transmits and receives MLT3 symbols. When not transmitting data, the LXT973 Transceiver generates IDLE symbols.

During 10 Mbps operation, Manchester-encoded data is exchanged. When no data is being exchanged, the line is left in an idle state. Link pulses are transmitted periodically to keep the link up.

The LXT973 Transceiver supports either 100BASE-TX or 10BASE-T connections over 100Ω, Category 5, Unshielded Twisted-Pair (UTP) cable. Only a transformer, RJ-45 connector, and bypass capacitors are required to complete this interface. On the transmit side, the waveshaping technology shapes the outgoing signal to help reduce the need for external EMI filters. Four slew rate settings (refer to [Table 5 on page 20](#)) allow the designer to match the output waveform to the magnetic characteristics.

### 3.7.3 Fiber Interface

The LXT973 Transceiver fiber port is designed to interface with common industry-standard fiber modules. It incorporates a PECL interface that complies with the ANSI X3.166 standard for seamless integration.

Fiber mode is selected by putting a low level on the Fiber\_TP $n$  pin. This is only sensed upon completion of reset.

### 3.7.4 Fault Detection and Reporting

The LXT973 Transceiver supports two fault detection and reporting mechanisms. "Remote Fault" refers to a MAC-to-MAC communication function that is essentially transparent to PHY layer devices, and is used only during auto-negotiation. Therefore, Remote Fault is applicable only to twisted-pair links. "Far End Fault" is an optional PMA-layer function that may be embedded within PHY devices. The LXT973 Transceiver supports both functions, which are explained in more detail in sections that follow.

### 3.7.5 Remote Fault

Register bit 4.13 in the Auto-Negotiation Advertisement Register is reserved for Remote Fault indications. This bit is typically used when restarting the auto-negotiation sequence, indicating to the link partner that link is down because the advertising device detected a fault.

When the LXT973 Transceiver receives a Remote Fault indication from its partner during auto-negotiation it:

- Sets Register bit 5.13 in the Link Partner Base Page Ability Register, and
- Sets the Remote Fault Register bit 1.4 in the MII Status Register to pass this information to the local controller.

### 3.7.6 Far End Fault

In fiber mode, the  $SD_n$  pin monitors signal quality. If signal quality degrades beyond the fault threshold, the fiber transceiver reports a signal quality fault condition via the  $SD_n$  pin. Loss of signal quality blocks any fiber data from being received and causes a loss of link.

If the LXT973 Transceiver detects a signal fault condition, it transmits the Far End Fault Indication (FEFI) over the fiber link. The FEFI consists of 84 consecutive “1s” followed by a single “0.” This pattern must be repeated at least three times. The LXT973 Transceiver transmits the Far-End Fault code a minimum of three times if all the following conditions are true:

- Fiber mode is selected.
- Far End Fault Code transmission is enabled (Register bit 16.2 = 1).
- Signal Detect indicates either no signal or the receive PLL cannot lock.
- Loopback is not enabled.

## 3.8 100 Mbps Operation

### 3.8.1 100BASE-X Network Operations

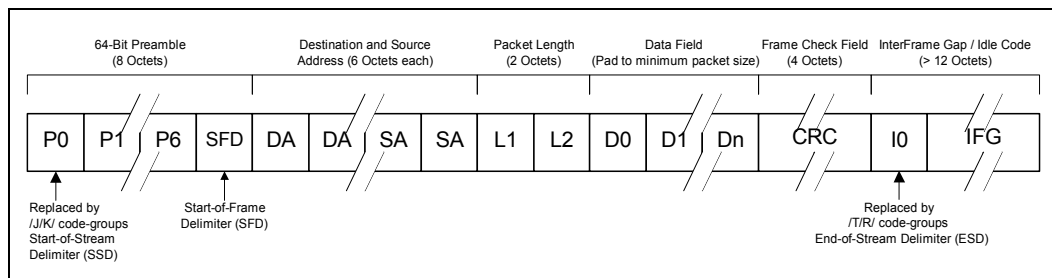
During 100BASE-X operation, the LXT973 Transceiver transmits and receives 5-bit symbols across the network link. Figure 9 shows the structure of a standard frame packet. When the MAC is not actively transmitting data, the LXT973 Transceiver sends out IDLE symbols on the line.

In 100BASE-TX mode, the device scrambles the data and transmits it to the network using MLT-3 line code. The MLT-3 signals received from the network are de-scrambled and decoded, and sent across the MII to the MAC.

In 100BASE-FX mode, the LXT973 Transceiver transmits and receives NRZI signals across the LVPECL interface. An external 100BASE-FX transceiver module is required to complete the fiber connection.

As shown in Figure 9, the MAC starts each transmission with a preamble pattern. As soon as the LXT973 Transceiver detects the start of preamble, it transmits a J/K Start-of-Stream Delimiter (SSD) symbol to the network. It then encodes and transmits the rest of the packet, including the balance of the preamble, the Start-of-Frame Delimiter (SFD), packet data, and CRC. Once the packet ends, the LXT973 Transceiver transmits the T/R End-of-Stream Delimiter (ESD) symbol and returns to transmitting IDLE symbols.

**Figure 9 100BASE-X Frame Format**



---

### 3.8.2 100BASE-X Protocol Sublayer Operations

In the seven-layer OSI communications model, the LXT973 Transceiver is a Physical Layer 1 (PHY) device. The LXT973 Transceiver implements the Physical Coding Sublayer (PCS), Physical Medium Attachment (PMA), and Physical Medium Dependent (PMD) sublayers of the reference model defined by the IEEE 802.3u specification. The following paragraphs discuss the LXT973 Transceiver operation from the reference model point of view.

### 3.8.3 PCS Sublayer

The Physical Coding Sublayer (PCS) provides the MII interface, as well as the 4B/5B encoding/decoding function. For 100BASE-TX and 100BASE-FX operation, the PCS layer provides IDLE symbols to the PMD-layer line driver as long as TXEN is de-asserted. For 10BASE-T operation, the PCS layer merely provides a bus interface and serialization/de-serialization function. 10BASE-T operation does not use the 4B/5B encoder.

#### 3.8.3.1 Preamble Handling

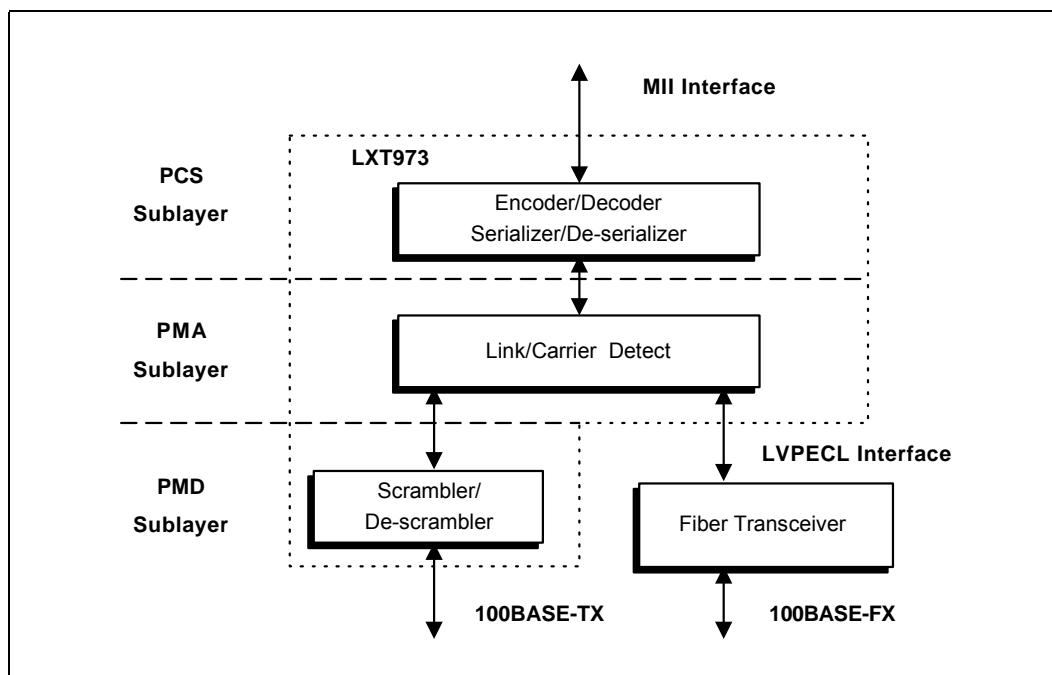
When the MAC asserts TXEN, the PCS substitutes a /J/K/ symbol pair, also known as the Start-of-Stream Delimiter (SSD), for the first two nibbles received across the MII. The PCS layer continues to encode the remaining MII data until TXEN is de-asserted. It then returns to supplying IDLE symbols to the line driver.

The PCS layer performs the opposite function in the receive direction by substituting two preamble nibbles for the SSD.

#### 3.8.3.2 Dribble Bits

The LXT973 Transceiver handles dribble bits in all modes. If one through four dribble bits are received, the nibble is passed across the MII, and padded with ones if necessary. If five through seven dribble bits are received, the second nibble is not sent to the MII bus.

**Figure 10 Protocol Sublayers**



### 3.8.4 PMA Sublayer

#### 3.8.4.1 Link Failure Override

The LXT973 Transceiver normally transmits 100 Mbps data packets or IDLE symbols only if it detects that link is up, and transmits FLP bursts in auto-negotiation mode or IDLE symbols in forced mode. Setting Register bit 16.14 = 1 overrides this function, allowing the LXT973 Transceiver to transmit data packets even when link is down. This feature is provided as a diagnostic tool.

**Note:** Auto-negotiation must be disabled to transmit data packets in the absence of link. If auto-negotiation is enabled, the LXT973 Transceiver automatically begins transmitting FLP bursts if the link goes down.

#### 3.8.4.2 Carrier Sense

For 100BASE-TX and 100BASE-FX links, a Start-of-Stream Delimiter (SSD) or /J/K/ symbol pair causes assertion of carrier sense (CRS). An End-of-Stream Delimiter (ESD), or /T/R/ symbol pair causes de-assertion of CRS. The PMA layer also de-asserts CRS if IDLE symbols are received without /T/R/. In this event, the RXER bit in the RX Status Frame is asserted for one clock cycle when CRS is de-asserted.

#### 3.8.4.3 Twisted-Pair PMD Sublayer

The twisted-pair Physical Medium Dependent (PMD) layer provides the signal scrambling and descrambling, line coding and decoding (MLT-3), as well as receiving, polarity correction, and baseline wander correction functions.

#### 3.8.4.4 Scrambler/Descrambler

The purpose of the scrambler is to spread the signal power spectrum and further reduce EMI using an 11-bit, non-data-dependent polynomial. The receiver automatically decodes the polynomial whenever IDLE symbols are received.

The scrambler/de scrambler can be bypassed by setting Register bit 16.12 = 1. The scrambler is automatically bypassed when the fiber port is enabled. Scrambler bypass is provided for diagnostic and test support.

#### 3.8.4.5 Baseline Wander Correction

The LXT973 Transceiver provides a baseline wander correction function which makes the device robust under all network operating conditions. The MLT3 coding scheme used in 100BASE-TX is, by definition, “unbalanced.” This means that the DC average value of the signal voltage can “wander” significantly over short time intervals (tenths of seconds). This wander may cause receiver errors, particularly in less robust designs, at long-line lengths (100 meters). The exact characteristics of the wander are completely data dependent.

The LXT973 Transceiver baseline wander correction characteristics allow the device to recover error-free data while receiving worst-case “killer” packets over all cable lengths.

#### 3.8.5 Fiber PMD Sublayer

The LXT973 Transceiver provides an LVPECL interface for connection to an external 3.3 V or 5 V fiber-optic transceiver. (The external transceiver provides the PMD function for the optical medium.) The LXT973 Transceiver uses a 125 Mbaud NRZI format for the fiber interface, and does not support 10BASE-FL applications.

##### 3.8.5.1 Far End Fault Indications

The LXT973 Transceiver Signal Detect pins independently detect signal faults from the local fiber transceivers via the SD pins. The device also uses Register bit 1.4 to report Remote Fault indications received from its link partner. The device ORs both fault conditions to set Register bit 1.4. This bit is set once and cleared when read.

Either fault condition causes the LXT973 Transceiver to drop the link unless Forced Link Pass is selected (Register bit 16.14 = 1). A link-down condition is then reported via status bits.

In response to locally detected signal faults (SD activated by the local fiber transceiver), the affected port can transmit the Far End Fault code if a fault code transmission is enabled by Register bit 16.2.

- When Register bit 16.2 = 1, transmission of the Far End Fault code is enabled. The LXT973 Transceiver transmits Far End Fault code if fault conditions are detected by the Signal Detect pins.
- When Register bit 16.2 = 0, the LXT973 Transceiver does not transmit Far End Fault code. It continues to transmit IDLE code and may or may not drop link, depending on the setting for Register bit 16.14.

The occurrence of a Far End Fault causes all transmission of data from the Reconciliation Sublayer to stop and the Far End fault code to begin. The Far End Fault code consists of 84 “1s” followed by a single “0”, and is repeated until the Far End Fault condition is removed.

---

## 3.9 10 Mbps Operation

The LXT973 Transceiver operates as a standard 10BASE-T transceiver and supports all the standard 10 Mbps functions. During 10BASE-T operation, the LXT973 Transceiver transmits and receives Manchester-encoded data across the network link. When the MAC is not actively transmitting data, the device sends out link pulses on the line.

In 10BASE-T mode, the polynomial scrambler/de-scrambler is inactive. Manchester-encoded signals received from the network are decoded by the LXT973 Transceiver and sent across the MII to the MAC.

**Note:** The LXT973 Transceiver does not support fiber connections at 10 Mbps.

### 3.9.1 Polarity Correction

The LXT973 Transceiver automatically detects and corrects for an inverted receive signal. Reversed polarity is detected if eight inverted link pulses or four inverted End-of-Frame (EOF) markers are received consecutively. If link pulses or data are not received by the maximum receive time-out period, the polarity state is reset to a non-inverted state.

### 3.9.2 Dribble Bits

The LXT973 Transceiver device handles dribble bits in all modes. If one through four dribble bits are received, the nibble is passed across the MII. If five through seven dribble bits are received, the second nibble is not sent to the MII bus.

### 3.9.3 Link Test

The LXT973 Transceiver always transmits link pulses in 10BASE-T mode. When enabled, the link test function monitors the connection for link pulses. Once link pulses are detected, data transmission is enabled and remains enabled as long as either the link pulses or data transmission continues. If link pulses stop, the data transmission is disabled.

If the link test function is disabled, the LXT973 Transceiver transmits to the connection regardless of detected link pulses. The link test function is disabled by setting Register bit 16.14 = 1.

### 3.9.4 Link Failure

Link failure occurs if Link Test is enabled and link pulses or packets stop being received. If this condition occurs, the LXT973 Transceiver returns to the auto-negotiation phase if auto-negotiation is enabled.

### 3.9.5 Jabber

If a transmission exceeds the jabber timer, the LXT973 Transceiver disables the transmit and loopback functions. The LXT973 Transceiver automatically exits jabber mode after the unjab time has expired. This function is disabled by setting Register bit 16.10 = 1.



## 3.10 Monitoring Operations

### 3.10.1 Monitoring Auto-Negotiation

Auto-negotiation may be monitored as follows:

- Link Status Register bit 1.2 = 1 once the link is established.
- Additional bits in Register 1 can be used to determine the link operating conditions and status (refer to [Table 17 on page 67](#)).

### 3.10.2 Per-Port LED Driver Functions

The LXT973 Transceiver incorporates three direct drive LEDs per port (LED<sub>n\_1</sub>, LED<sub>n\_2</sub>, and LED<sub>n\_3</sub>). On power-up, all the LEDs light up for approximately one second after reset de-asserts. Each LED may be configured to one of several different display modes using the LED Configuration Pins, as shown in [Table 10 on page 41](#).

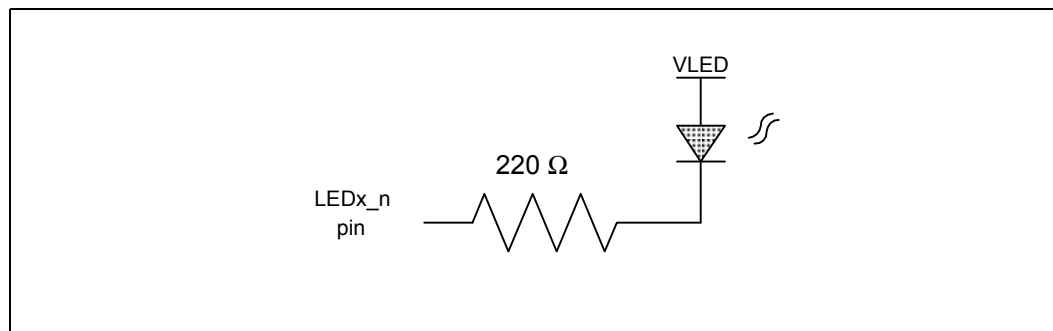
The LED driver pins are open drain circuits (10 mA maximum current rating). If an LED<sub>x\_n</sub> pin is unused, terminate with a 10KΩ pull-up resistor. [Figure 11](#) shows a typical LED implementation. When configured for modes 2 or 4, the LEDs blink at the rate of 100 ms to display multiple status.

[Table 10](#) provides LED configurations for the LXT973 Transceiver.

**Table 10 LED Configurations**

LED_CFG0	LED_CFG1	LED <sub>n_1</sub>	LED <sub>n_2</sub>	LED <sub>n_3</sub>
0	0	Speed	Link	Duplex
1	0	Speed	Link/Activity	Duplex/Collision
0	1	Link	Receive	Transmit
1	1	Speed	Link/MII Isolate	Duplex/Collision

**Figure 11 Typical LED Implementation**



---

## 4.0 Application Information

### 4.1 Design Recommendations

The LXT973 Transceiver is designed to comply with IEEE 802.3 requirements to provide outstanding receive Bit Error Rate (BER), and long-line-length performance. To achieve maximum performance from the LXT973 Transceiver, attention to detail and good design practices are required. *Refer to the LXT973 Transceiver Design and Layout Guide for detailed design and layout information.*

#### 4.1.1 General Design Guidelines

Adherence to generally accepted design practices is essential to minimize noise levels on power and ground planes. Up to a maximum noise level of 50 mV is considered acceptable. High-frequency switching noise can be reduced, and its effects eliminated, by following these simple guidelines throughout the design:

- Fill in unused areas of the signal planes with solid copper and attach them with vias to a VCC or ground plane that is not located adjacent to the signal layer.
- Use ample bulk and de-coupling capacitors throughout the design (a value of 0.01  $\mu$ F is recommended for de-coupling caps).
- Provide ample power and ground planes.
- Provide termination on all high-speed switching signals and clock lines.
- Provide impedance matching on long traces to prevent reflections.
- Route high-speed signals next to a continuous, unbroken ground plane.
- Filter and shield DC-to-DC converters, oscillators, etc.
- Do not route any digital signals between the LXT973 Transceiver and the RJ-45 connectors at the edge of the board.
- Do not extend any circuit power and ground planes past the center of the magnetics or to the edge of the board. Use this area for chassis ground, or leave it void.

#### 4.1.2 Power Supply Filtering

Power supply ripple and digital switching noise on the VCC plane may cause EMI problems and degrade line performance. To minimize ground noise as much as possible, use good general techniques and filter the VCC plane. It is difficult to predict in advance the performance of any design, although certain factors greatly increase the risk of having problems:

- Poorly-regulated or over-burdened power supplies.
- Wide data busses (32-bits+) running at a high clock rate.
- DC-to-DC converters.

Cortina recommends filtering the power supply to the analog VCC pins of the LXT973 Transceiver. This has two benefits. First, it keeps digital switching noise out of the analog circuitry inside the LXT973 Transceiver, helping with line performance. Second, if the VCC planes are laid out correctly, digital switching noise is kept away from external connectors, reducing EMI problems.

The recommended implementation is to break the VCC plane into two sections. The digital section supplies power to the VCCD and VCCIO pins of the LXT973 Transceiver. The analog section supplies power to the VCCR, VCCT, VCCPECL pins. The break between the two planes should run underneath the device. In designs with more than one LXT973 Transceiver device, a single continuous analog VCC plane can be used to supply them all.

The digital and analog VCC planes should be joined at one or more points by ferrite beads. The beads should produce at least a 100Ω impedance at 100 MHz. Beads should be placed so that current flow is evenly distributed. The maximum current rating of the beads should be at least 150% of the current that is actually expected to flow through them. A bulk cap (2.2 -10 μF) should be placed on each side of each bead. In addition, a high-frequency bypass cap (0.01 μF) should be placed near each analog VCC pin.

### 4.1.3 Power and Ground Plane Layout Considerations

Great care needs to be taken when laying out the power and ground planes.

- Follow the guidelines in the LXT973 Transceiver *Design and Layout Guide* for locating the split between the digital and analog VCC planes.
- Keep the digital VCC plane away from the DPAP/N<sub>n</sub> and DPBP/N<sub>n</sub> signals, the magnetics, and the RJ-45 connectors.
- Place the layers so that the DPAP/N<sub>n</sub> and DPBP/N<sub>n</sub> signals can be routed near or next to the ground plane.

#### 4.1.3.1 Chassis Ground

For ESD reasons, it is a good design practice to create a separate chassis ground that encircles the board and is isolated via moats and keep-out areas from all circuit-ground planes and active signals. Chassis ground should extend from the RJ-45 connectors to the magnetics, and can be used to terminate unused signal pairs (Bob Smith termination). In single-point grounding applications, provide a single connection between chassis and circuit grounds with a 2 kV isolation capacitor. In multi-point grounding schemes (chassis and circuit grounds joined at multiple points), provide 2 kV isolation to the Bob Smith termination.

#### 4.1.4 MII Terminations

Series termination resistors are generally required. Keep all traces orthogonal and as short as possible. Whenever possible, route the clock traces evenly between the longest and shortest data routes. This minimizes round-trip, clock-to-data delays and allows a larger margin to the setup and hold requirements. Please refer to the LXT973 Transceiver *Design and Layout Guide* for series resistor values.

### 4.1.5 The Fiber Interface

The fiber interface consists of an LVPECL transmit and receive pair to an external fiber-optic transceiver. Both 3.3 V fiber-optic transceivers and 5 V fiber-optic transceivers can be used with the LXT973 Transceiver. See the 100BASE-FX Fiber Optic Transceivers-Connecting a PECL/LVPECL Interface Application Note (document number 250781) for detailed information on fiber interface designs and recommendations for Cortina PHYs.

The following should occur in 3.3 V fiber transceiver applications as shown in [Figure 14](#):

- The transmit pair should be AC-coupled with 2.5 V supplies and re-biased to 3.3 VLVPECL levels
- The transmit pair should contain a balance offset in the pull-up resistors to prevent PHY-to-fiber transceiver crosstalk amplification in power-down, loopback, and reset states (see fiber interface application note)
- The receive pair should be DC-coupled with an emitter current path for the fiber transceiver
- The signal detect pin should be DC-coupled with an emitter current path for the fiber transceiver

Refer to the fiber transceiver manufacturers' recommendations for termination circuitry. [Figure 14, Recommended LXT973 Transceiver Transceiver-to-3.3 V Fiber Transceiver Interface Circuitry, on page 48](#) shows a typical example of an LXT973 Transceiver-to-3.3 V fiber transceiver interface.

The following occurs in 5 V fiber transceiver applications as shown in [Figure 15, Recommended LXT973 Transceiver-to-5 V Fiber Transceiver Interface Circuitry, on page 49](#):

- The transmit pair should be AC-coupled and re-biased to 5 V PECL input levels
- The transmit pair should contain a balance offset in the pull-up resistors to prevent PHY-to-fiber transceiver crosstalk amplification in power-down, loopback, and reset states (see fiber interface application note)
- The receive pair should be AC-coupled with an emitter current path for the fiber transceiver and re-biased to 1.2 V
- The signal detect pin on a 5 V fiber transceiver interface should use the logic translator circuitry as shown in [Figure 16, ON Semiconductor\\* Triple PECL-to-LVPECL Logic Translator, on page 50](#).

Refer to the fiber transceiver manufacturers' recommendations for termination circuitry. [Figure 15](#) shows a typical example of an LXT973 Transceiver-to-5 V fiber transceiver interface, while [Figure 16](#) shows the interface circuitry for the logic translator.

### 4.1.6 Twisted-Pair Interface

Use the following standard guidelines for a twisted-pair interface:

- Place the magnetics as close as possible to the LXT973 Transceiver.
- Keep transmit pair traces as short as possible; both traces should have the same length.
- Avoid vias and layer changes as much as possible.
- Keep the transmit and receive pairs apart to avoid cross-talk.
- Route the transmit pair adjacent to a ground plane. The optimum arrangement is to place the transmit traces two to three layers from the ground plane with no intervening signals.
- Improve EMI performance by filtering the TPO center tap. A single ferrite bead rated at 100 mA may be used to supply center tap current to all ports.

### 4.1.7 Magnetics Information

The LXT973 Transceiver requires a 1:1 ratio for the receive transformers and a 1:1 ratio for the transmit transformers. The transformer isolation voltage should be rated at 2 kV to protect the circuitry from static voltages across the connectors and cables. The LXT973 Transceiver is a current-driven transceiver that requires an external voltage (center tap) to drive the transmit signal. To support LXT973 Transceiver auto MDI/MDIX functionality, the magnetic must provide a center tap for both transmit and receive magnetic windings, with both connected to VCCT (see [Figure 13 on page 47](#)). When using the auto MDI/MDIX function, select a magnetic so that both transmit and receive windings are matched or balanced (refer to the LXT973 Transceiver Design and Layout Guide – document number 249631). Refer to [Table 11](#) for transformer requirements. Before committing to a specific component, designers should contact the manufacturer for current product specifications, and validate the magnetics for the specific application.

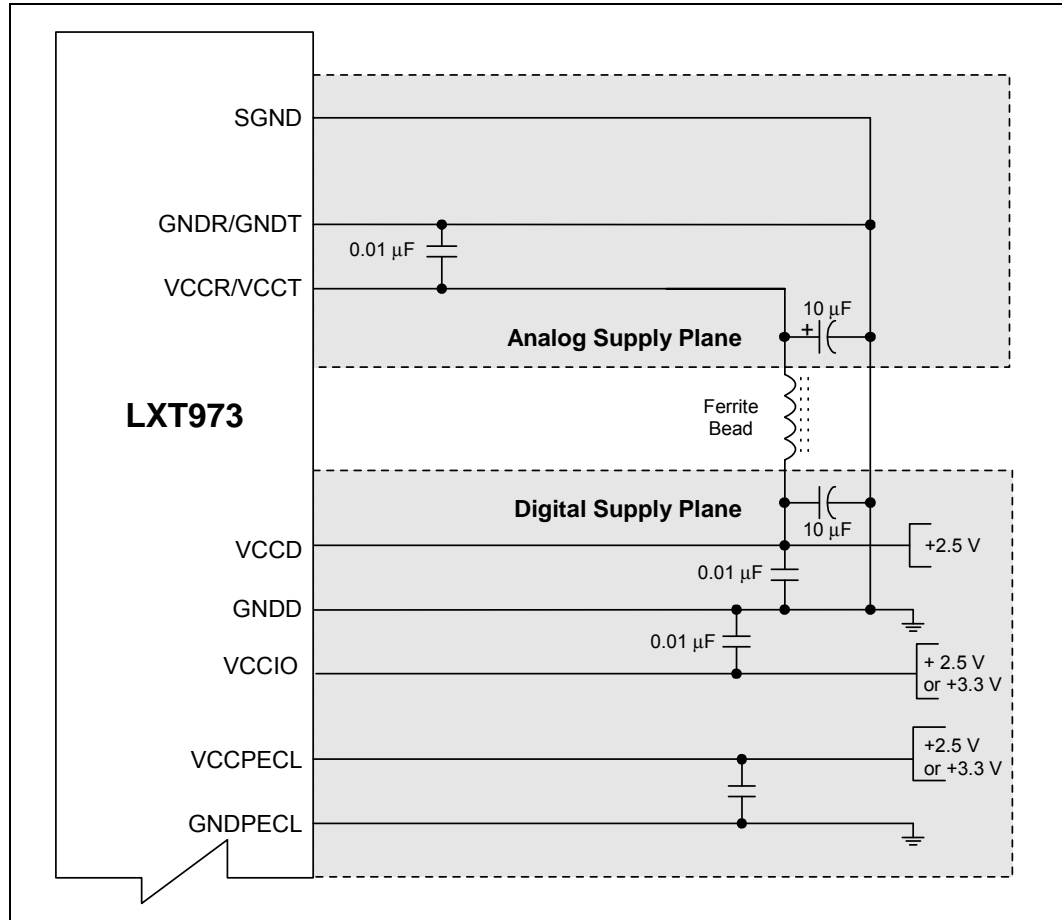
**Table 11 Magnetics Requirements**

Parameter	Min	Nom	Max	Units	Test Condition
Rx turns ratio	–	1:1	–	–	–
Tx turns ratio	–	1:1	–	–	–
Insertion loss	0.0	0.6	1.1	dB	–
Primary inductance	350	–	–	μH	–
Transformer isolation	2	–	–	kV	–
Differential to common mode rejection	40	–	–	dB	.1 to 60 MHz
	35	–	–	dB	60 to 100 MHz
Return Loss	-16	–	–	dB	30 MHz
	-10	–	–	dB	80 MHz

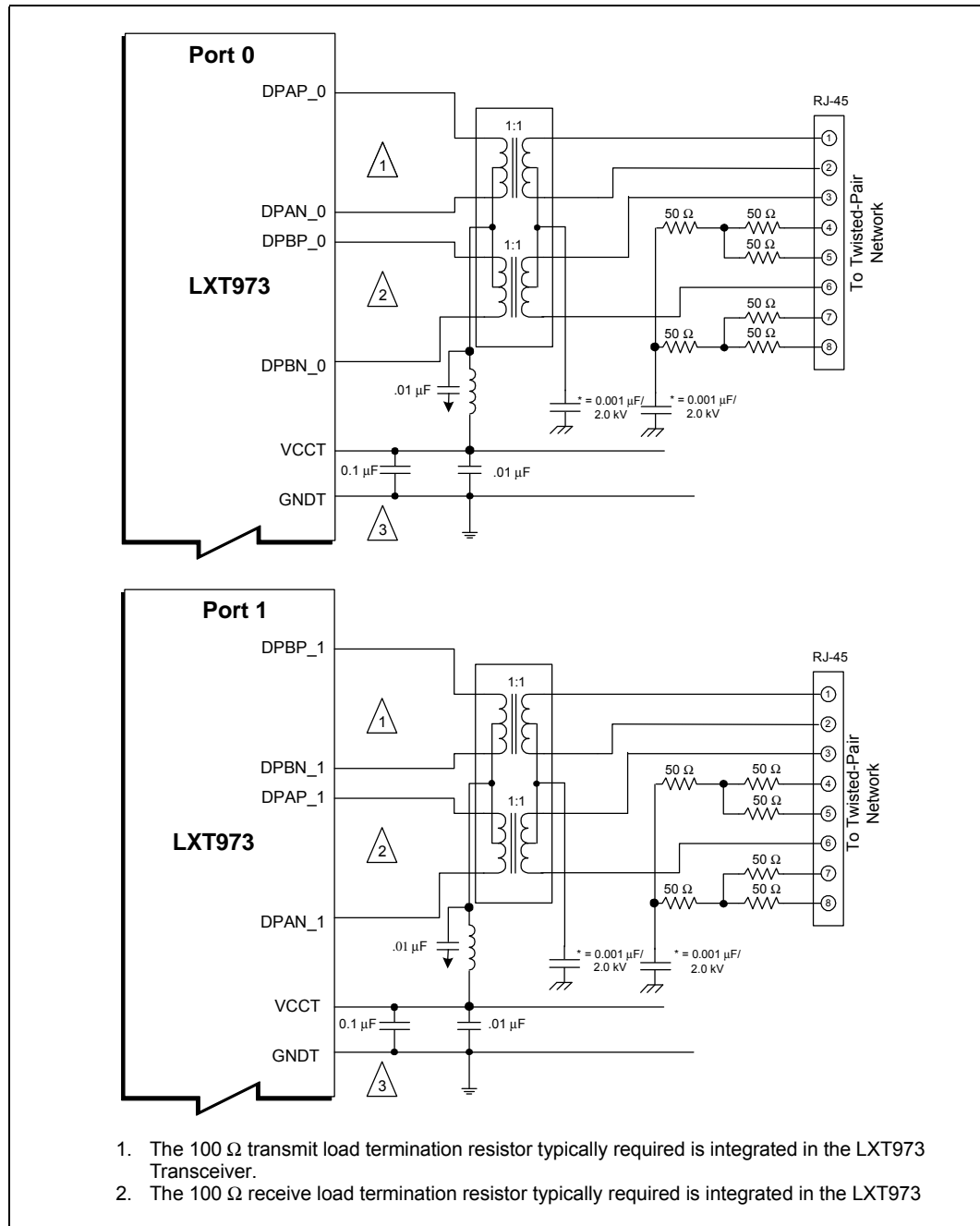
## 4.2 Typical Application Circuits

Figure 12 through Figure 17 on page 50 show typical application circuits for the LXT973 Transceiver.

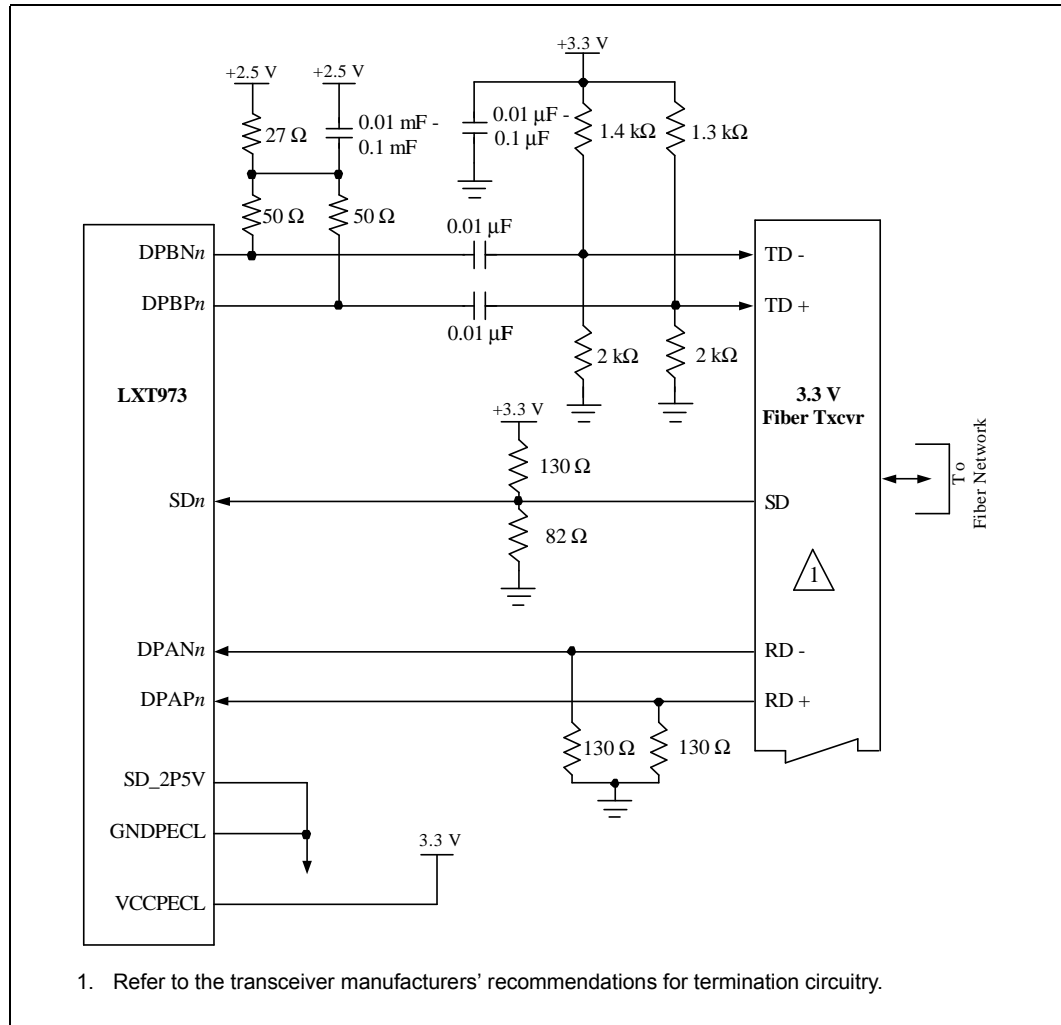
**Figure 12 Power and Ground Supply Connections**



**Figure 13 Typical Twisted-Pair Interface**

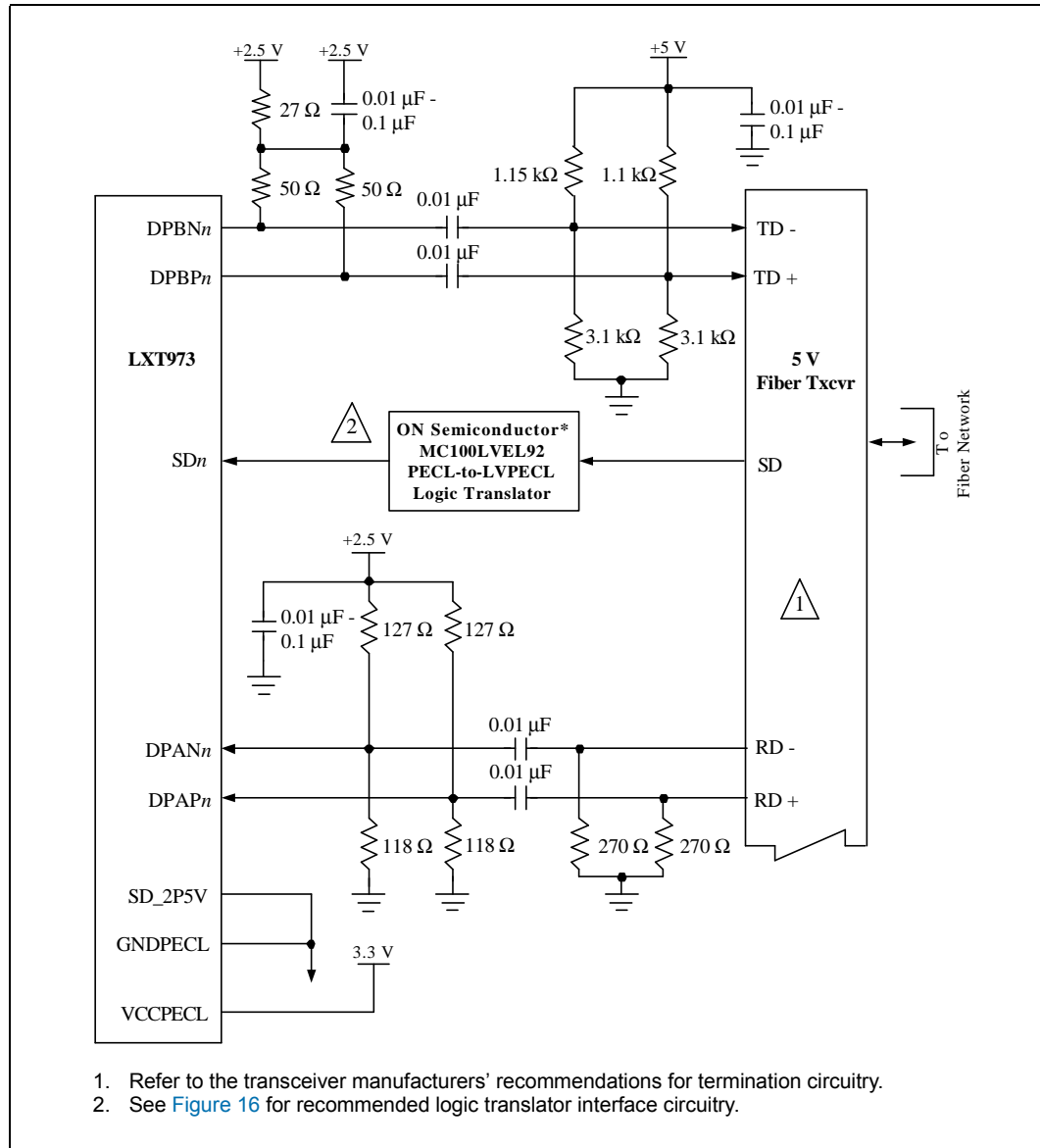


**Figure 14 Recommended LXT973 Transceiver Transceiver-to-3.3 V Fiber Transceiver Interface Circuitry**

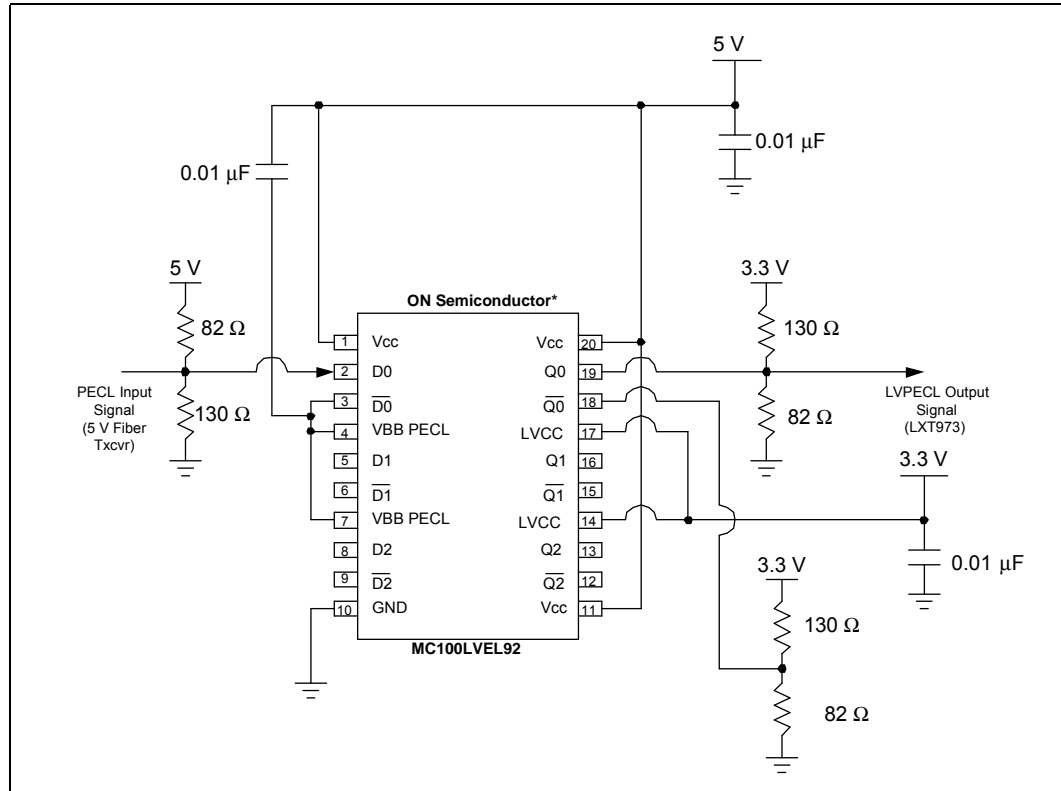




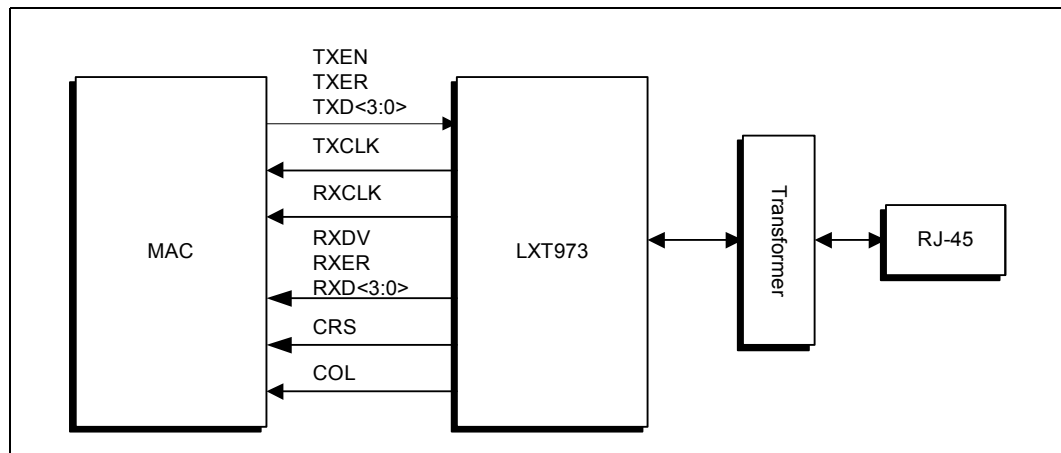
**Figure 15 Recommended LXT973 Transceiver-to-5 V Fiber Transceiver Interface Circuitry**



**Figure 16 ON Semiconductor\* Triple PECL-to-LVPECL Logic Translator**



**Figure 17 Typical MII Interface**



---

## 4.3 Initialization

At power-up or reset, the LXT973 Transceiver performs the initialization as shown in [Figure 18 on page 52](#). When the MDDIS $n$  pin is High, the LXT973 Transceiver enters Manual Control Mode for that port. When MDDIS $n$  is Low, MDIO Control Mode is enabled for that port. Mode control selection is provided via the MDDIS $n$  pin as shown in [Table 12 on page 52](#).

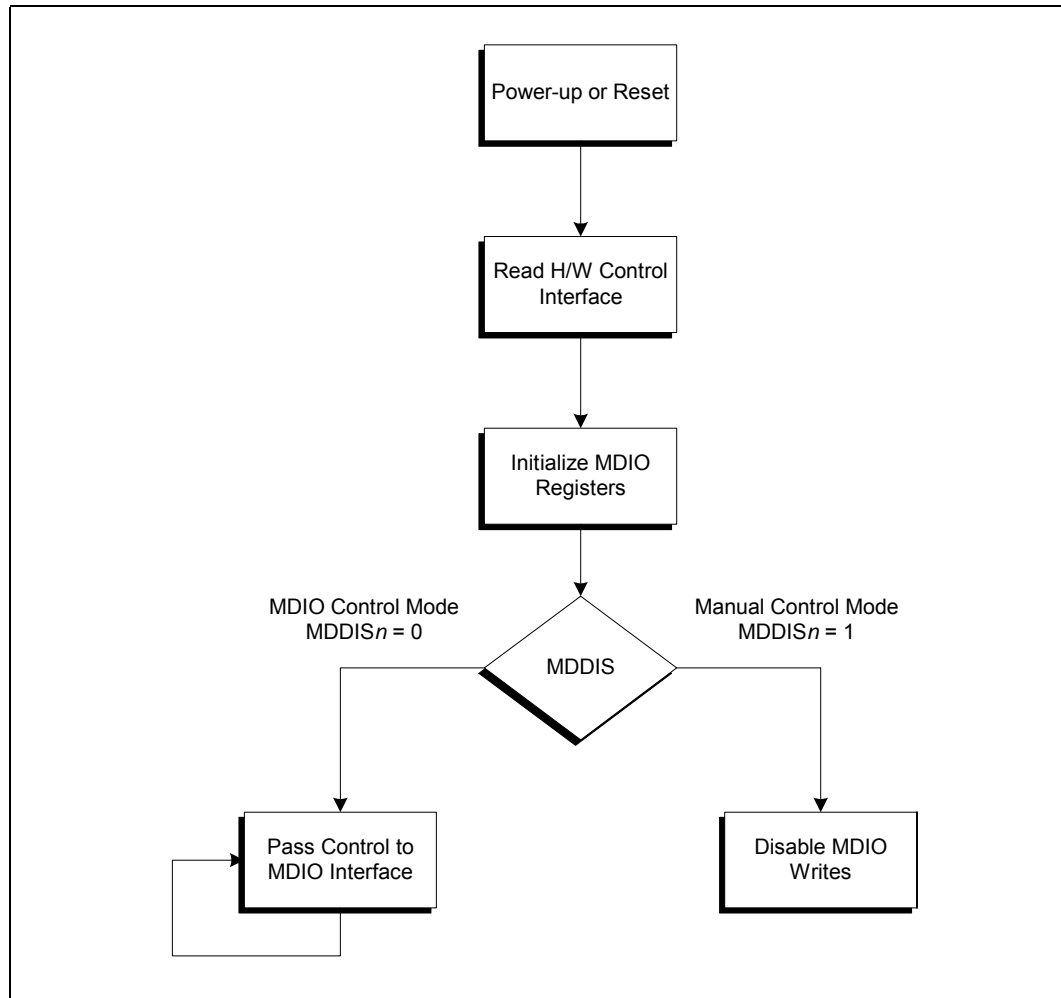
## 4.4 MDIO Control Mode

In the MDIO Control mode, the LXT973 Transceiver uses the Hardware Control Interface to set up initial (default) values of the MDIO registers. Once initial values are set, bit control reverts to the MDIO interface.

## 4.5 Manual Control Mode

In the Manual Control Mode, LXT973 Transceiver disables direct write operations to the MDIO registers on the MDIO interface. The Hardware Control Interface is monitored during Reset to set up the MDIO registers.

**Figure 18 Initialization Sequence**



**Table 12 Mode Control Settings**

MDDISn	RESET	PWRDWN	Mode
Low	High	Low	MDIO Control
High	High	Low	Manual Control
-	Low	Low	Reset - Latch default configuration
-	-	High	Low Power and reset mode

## 5.0 Configuration

When the LXT973 Transceiver is first powered on, reset, or encounters a link-down state, it must determine the line speed and operating conditions to use for the network link. The LXT973 Transceiver first checks the MDIO registers (initialized via the Hardware Control interface or written by software) for operating instructions. Using these mechanisms, the user can command the LXT973 Transceiver to do one of the following:

- Forced 100BASE-FX operation
- Forced twisted-pair link operation to:
  - 100BASE-TX, full-duplex
  - 100BASE-TX, half-duplex
  - 10BASE-T, full-duplex
  - 10BASE-T, half-duplex
- Allow auto-negotiation/parallel-detection.

In forced twisted-pair link operation, the LXT973 Transceiver immediately begins operating the network interface as commanded. In the last case, the LXT973 Transceiver begins the auto-negotiation/parallel-detection process.

Several pins are used to configure the LXT973 Transceiver device. [Table 13](#) summarizes the available manual configurations to the port. Usually these pins are decodes of chip pins. This is useful for manual configuration.

**Table 13 Configuration Settings (Hardware Control Interface) (Sheet 1 of 2)**

FIBER_TPrn	AUTO_NEGx	SPEEDx	DUPLEXx	Mode
Low	–	–	Low	100BASE-FX is enabled in half-duplex mode. Auto-negotiation is disabled.
Low	–	–	High	100BASE-FX is enabled in full-duplex mode. Auto-negotiation is disabled.
High	High	High	High	AUTO_NEG is enabled. All capabilities are advertised. Register bits 4.8, 4.7, 4.6 and 4.5 are all set to 1.
High	High	High	Low	AUTO_NEG is enabled. Only 100 Mbps capabilities are advertised. Register bits 4.8 and 4.7 are set to 1. Register bits 4.6 and 4.5 are cleared to 0.
High	High	Low	High	AUTO_NEG is enabled. Only 10 Mbps capabilities are advertised. Register bits 4.8 and 4.7 are cleared to 0. Register bits 4.6 and 4.5 are set to 1.
High	High	Low	Low	AUTO_NEG is enabled. Only half-duplex capabilities are advertised. Register bits 4.7 and 4.5 are set 1. Register bits 4.8 and 4.6 are cleared to 0.
High	Low	High	High	AUTO_NEG is disabled. LXT973 Transceiver port x is forced to 100 Mbps full-duplex operation.

1. These pins also set the default values for Registers 0 and 4 accordingly.

**Table 13 Configuration Settings (Hardware Control Interface) (Sheet 2 of 2)**

<b>FIBER_TP<sub>n</sub></b>	<b>AUTO_NEG<sub>x</sub></b>	<b>SPEED<sub>x</sub></b>	<b>DUPLEX<sub>x</sub></b>	<b>Mode</b>
High	Low	High	Low	AUTO_NEG is disabled. LXT973 Transceiver port x is forced to 100 Mbps half-duplex operation.
High	Low	Low	High	AUTO_NEG is disabled. LXT973 Transceiver port x is forced to 10 Mbps full-duplex operation.
High	Low	Low	Low	AUTO_NEG is disabled. LXT973 Transceiver port x is forced to 10 Mbps half-duplex operation.
1. These pins also set the default values for Registers 0 and 4 accordingly.				

## 6.0 Auto Negotiation

The LXT973 Transceiver PHY supports the IEEE 802.3u auto-negotiation scheme with Next Page capability. Next Page exchange utilizes Register 7 to send information and Register 8 to receive them. Next Page exchange can only occur if both ends of the link advertise their ability to exchange Next Pages.

The LXT973 Transceiver is configured to make Next Page exchange easier for software. When a Base Page or Next Page is received, the Page Received Register bit 6.1 remains set until read. When Register bit 6.2 (Next Page Able) is received, it stays set until read. This bit is cleared whenever a new negotiation occurs. This prevents the user from reading an old value in Register 6 and assuming there is valid information in Registers 5 and 8. Additionally, Register 6 contains a new bit (Register bit 6.5) that indicates when the current Received Page is the Base Page. This information is useful for recognizing when next pages must be re-sent due to the start of a new negotiation process. Register bit 16.1 and the Page Received bit (Register bit 6.1) are also cleared upon reading Register 6.

Next Page Encoding	D15	D14	D13	D12	D11	D10	D9	D8	D7	D6	D5	D4	D3	D2	D1	D0
OUI tagged Message	1	a	1	0	t	0	0	0	0	0	0	0	0	1	0	1
user page 1	1	a	0	0	t	3.10	3.11	3.12	3.13	3.14	3.15	2.0	2.1	2.2	2.3	2.4
user page 2	1	a	0	0	t	2.5	2.6	2.7	2.8	2.9	2.10	2.11	2.12	2.13	2.14	2.15
user page 3	1	a	0	0	t	0	0	L.8	L.7	L.6	L.5	L.4	L.3	L.2	L.1	L.0
user page 4	1	a	0	0	t	L.10	L.9	L.8	L.7	L.6	L.5	L.4	L.3	L.2	L.1	L.0

1. a is the acknowledge bit; t is the toggle bit; L is the LFSR.

---

## 7.0 Auto-MDI/MDIX

Twisted-pair Ethernet PHYs must be correctly configured for MDI or MDIX operation to inter operate. This has historically been accomplished using special patch cables, magnetics pinouts, or PCB wiring.

The LXT973 Transceiver PHY supports the automatic MDI/MDIX configuration originally developed for 1000BASE-T and standardized in IEEE 802.3u, section 40. A manual configuration (for example, non-automatic) is still possible using configuration register bits. The automatic MDI/MDIX function is not intended for fiber applications.

The automatic MDI/MDIX state machine facilitates switching of the twisted-pair input signals (DPBP/N\_0 and DPAP/N\_1) with the twisted-pair output signals (DPAP/N\_0 and DPBP/N\_1), respectively, prior to the auto-negotiation mode of operation. This is done so that FLPs can be transmitted and received in compliance with Clause 28, Auto-Negotiation specifications.

The correct polarization of the crossover circuit is determined by an algorithm that controls the switching function. This algorithm uses an 11-bit Linear Feedback Shift Register (LFSR) to create a pseudo-random sequence that each end of the link uses to determine its proposed configuration.

After selecting MDI or MDIX, the node waits for a specified amount of time, while evaluating its receive channel, to determine whether the other end of the link is sending link pulses or PHY-dependent data. If link pulses or PHY-dependent data are detected, it remains in that configuration. If link pulses or PHY-dependent data are not detected, it increments its LFSR and makes a decision to switch based on the value of the next bit. The state machine does not move from one state to another while link pulses are being transmitted.



## 8.0 100 Mbps Operation

The MAC passes data to the LXT973 Transceiver over the MII. The LXT973 Transceiver encodes and scrambles the data, then transmits it using MLT-3 (for 100BASE-TX-over-copper), or NRZI signaling (for 100BASE-FX-over-fiber). The LXT973 Transceiver descrambles and decodes MLT-3 data received from the network. When the MAC is not actively transmitting data, the LXT973 Transceiver sends out IDLE symbols on the line.

As shown in [Figure 19 on page 57](#), the MAC starts each transmission with a preamble pattern. When TXEN is asserted, the LXT973 Transceiver transmits a /J/K/ symbol to the network (Start of Stream Delimiter or SSD). It then encodes and transmits the rest of the packet, including the balance of the preamble, the SFD (Start of Frame Delimiter), packet data, and CRC. Once the packet ends, the LXT973 Transceiver transmits the /T/R/symbol (End-of-Stream Delimiter (ESD)) and then returns to transmitting IDLE symbols.

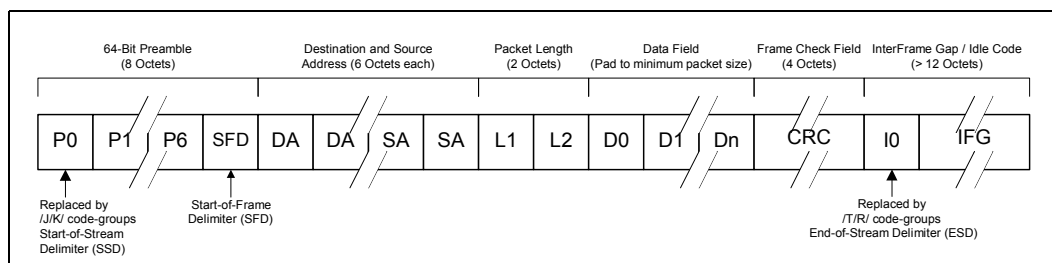
The encoder translates the 4-bit nibbles into 5-bit symbols, which are sent over the 100BASE-TX connection. A fifth bit is provided on pins TXER0 and TXER1 during symbol mode to allow a 5-bit symbol to be sent across the MII interface. The 5B encoder is bypassed in symbol mode.

[Figure 20 on page 57](#) shows the data conversion flow from nibbles to symbols.

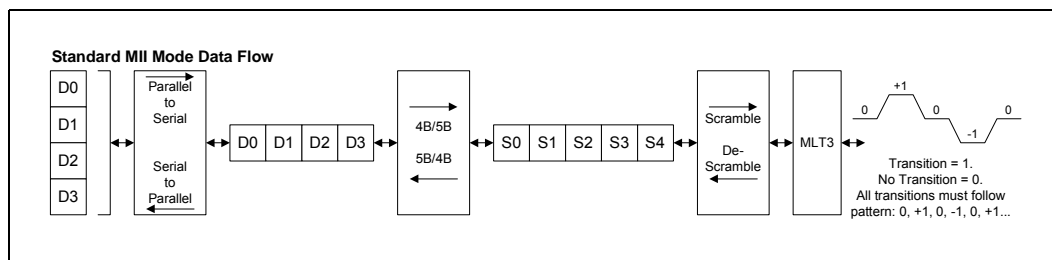
### 8.1 Displaying Symbol Errors

The PHY provides the MAC with an indication of errors that occur during the receive process. This output is called RXER. It is possible to map the symbol error detection output to the RXER pin using Register bit 26.9. In normal mode (Register bit 26.9 = 0), the RXER output is active per the IEEE 802.3 standard. When this register bit = 1, the RXER output goes active only when a symbol error is detected. This provides a quick measure of bit error rate.

**Figure 19 100BASE-TX Frame Format**



**Figure 20 100BASE-TX Data Path**



### 8.1.1 Scrambler Seeding

Once the transmit data (or IDLE symbols) are properly encoded, they are scrambled to further reduce EMI and to spread the power spectrum using an 11-bit scrambler seed. Five-seed bits are determined by global PHY address, and six-seed bits are selected by the port number. One of the 11 bits must be a “1”.

### 8.1.2 Scrambler Bypass

The scrambler can be bypassed by setting Register bit 16.12 = 1. Scrambler Bypass is provided for diagnostic and test support.

The descrambler cannot be bypassed. The 100BASE-TX receiver in the LXT973 Transceiver will not converge to unscrambled idle, so a descrambler bypass is useless.

### 8.1.3 100BASE-T Link Failure Criteria and Override

The LXT973 Transceiver normally transmits 100Mbps data packets only if it detects the link is up, and transmits only Idle symbols or FLP bursts if the link is not up. Setting Register bit 16.14 = 1 overrides this function, allowing the LXT973 Transceiver to transmit data packets even when the link is down. This feature is provided as a diagnostic tool. Note that auto-negotiation must be disabled to transmit data packets in the absence of link. If auto-negotiation is enabled, the LXT973 Transceiver automatically begins transmitting FLP bursts if the link goes down.

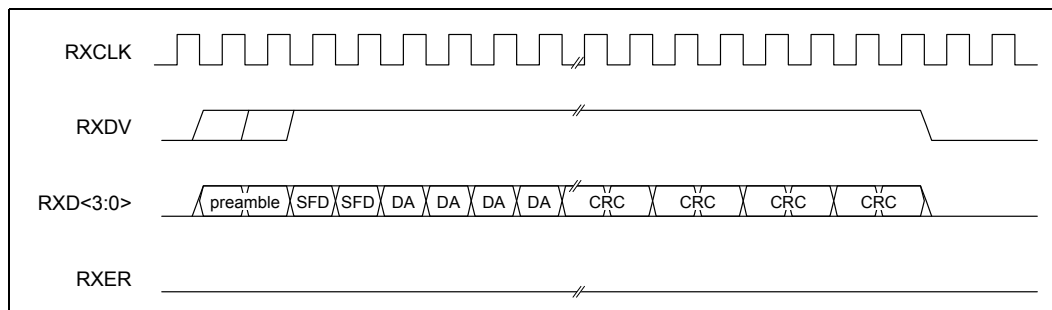
### 8.1.4 Baseline Wander Correction

The LXT973 Transceiver provides a baseline wander correction function which makes the device robust under all network operating conditions. The MLT3 coding scheme used in 100BASE-TX is by definition “unbalanced”. This means that the DC average value of the signal voltage can “wander” significantly over short time intervals (tenths of seconds). This wander can cause receiver errors, particularly at long line lengths (160 meters). The exact characteristics of the wander are completely data dependent. “Killer Packets” have been created that exhibit worst case baseline wander characteristics. The LXT973 Transceiver baseline wander correction characteristics allow the LXT973 Transceiver to recover error-free data, even at long line lengths.

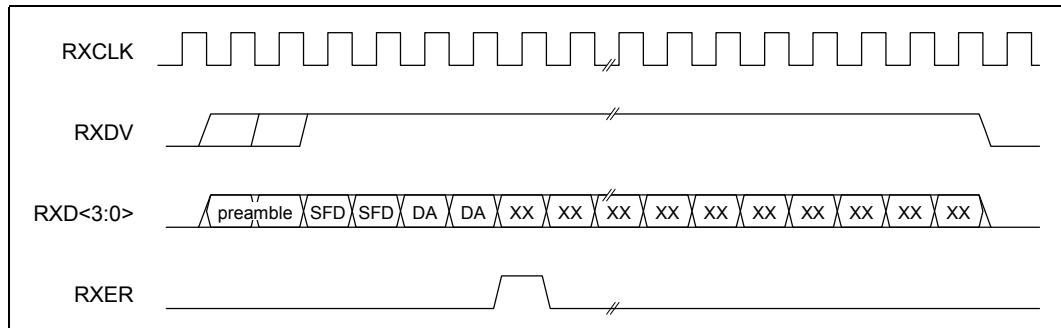
### 8.1.5 Programmable Tx Slew Rate

The LXT973 Transceiver device supports a slew rate mechanism where one of four pre-selected slew rates can be used, set either through the input pins or through Register 27.

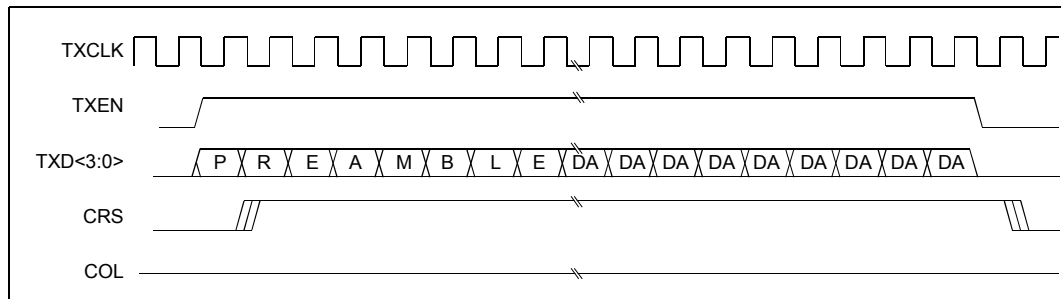
**Figure 21 100BASE-TX Reception with no Errors**



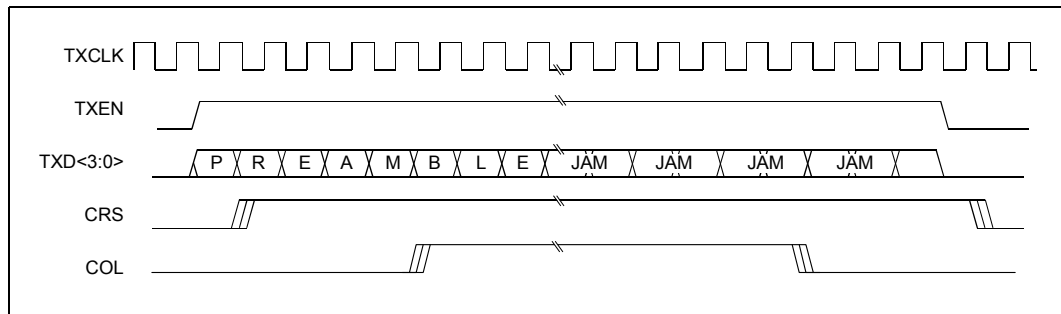
**Figure 22 100BASE-TX Reception with Invalid Symbol**



**Figure 23 100BASE-TX Transmission with no Errors**



**Figure 24 100BASE-TX Transmission with Collision**



---

## 9.0 Fiber Interface

The fiber ports of the LXT973 Transceiver are designed to connect to common industry standard fiber modules. The fiber ports incorporate LVPECL receivers and drivers, allowing for seamless integration. The LXT973 Transceiver provides a separate pin for the signal detect function. If designers wish to implement this feature, they need to provide a separate signal for this function. If the signal quality starts to degrade, this pin is essentially used to detect a remote fault condition and signals it accordingly. Loss of signal quality also blocks any fiber data from being received and causes a loss of link.

The remote fault code consists of 84 consecutive ones followed by a single zero. This pattern must be repeated at least three times. The LXT973 Transceiver transmits the remote fault code a minimum of three times if all the following conditions are true:

1. Signal Detect indicates no signal
2. Far End Fault Enable bit (Register bit 16.2 Test Register) is set
3. Auto-negotiation is not enabled
4. Fiber mode is selected

The remote fault (Register bit 1.4) is set when the LXT973 Transceiver is either actively transmitting a remote fault or if the LXT973 Transceiver has received a remote fault from its link partner. The transmitted remote fault can come from the above conditions if auto-negotiation is not enabled. If auto-negotiation is enabled, the transmitted remote fault condition is indicated by Register bit 4.13 in the Auto-Negotiation Advertisement Register. Likewise, a remote fault can be set by the LXT973 Transceiver link partner in two ways. If auto-negotiation is enabled, Register bit 5.13 is set in the Auto-Negotiation Link Partner Ability Register. If auto-negotiation is disabled, the remote fault condition is set by the remote fault code being received on the fiber inputs.

A register bit has been provided that either selects normal, unscrambled fiber data, or scrambles the transmitted fiber data (Register bit 26.10).

When in loopback mode, the remote fault condition is not transmitted.

---

## 10.0 10 Mbps Operation

The LXT973 Transceiver operates as a standard 10 Mbps transceiver. Data transmitted by the MAC as a 4-bit nibble is serialized, Manchester-encoded, and transmitted on the twisted-pair outputs (DPAP/N\_0 and DPBP/N\_1). Received data is decoded, de-serialized into 4-bit nibbles, and passed on RXD[3:0] to the MAC across the MII. The LXT973 Transceiver supports all the standard 10 Mbps functions.

### 10.1 Link Test

In 10 Mbps mode, the LXT973 Transceiver always transmits link pulses. If the Link Test Function is enabled, it monitors the connection for link pulses. Once it detects two to seven link pulses, data transmission is enabled and remains enabled as long as the link pulses or data reception continues. If the link pulses stop, the data transmission is disabled.

If the Link Test function is disabled, the LXT973 Transceiver may transmit packets regardless of detected link pulses. The Link Test function can be disabled by setting Port Configuration Register bit 16.14.

### 10.2 10Base-T Link Failure Criteria and Override

Link failure occurs if Link Test is enabled and link pulses stop being received. If this condition occurs, the LXT973 Transceiver returns to the auto-negotiation phase if auto-negotiation is enabled. If the Link Integrity Test function is disabled by setting the Port Configuration Register bit 16.14, the LXT973 Transceiver transmits packets, regardless of link status.

### 10.3 SQE (Heartbeat)

By default, the SQE (heartbeat) function is disabled on the LXT973 Transceiver. To enable this function, set Register bit 16.9 = 1. When this function is enabled, the LXT973 Transceiver asserts its COL output for 5 - 15 bit times after each packet. See [Figure 35 on page 87](#) for SQE timing parameters.

### 10.4 Jabber

If the MAC begins a transmission that exceeds the jabber timer, the LXT973 Transceiver disables the transmit and loopback functions and enables the COL pin. The LXT973 Transceiver automatically exits jabber mode after 250 - 750 ms. This function can be disabled by setting Register bit 16.10 = 1. See [Figure 36 on page 87](#) for jabber timing parameters.

### 10.5 Polarity Correction

The LXT973 Transceiver automatically detects and corrects for the condition where the receive signal (DPBP/N\_0 and DPAP/N\_1) is inverted. Reversed polarity is detected if 8 inverted link pulses, or 4 inverted end-of-frame markers, are received consecutively. If link pulses or data are not received for 96-130 ms, the polarity state is reset to a non-inverted state.

---

## 10.6 Dribble Bits

The LXT973 Transceiver device handles dribbles bits. If one to four dribble bits are received, the nibble is passed across the interface. The data passed across is padded with ones, if necessary. If five to seven dribble bits are received, the second nibble is not sent to the MII bus. This ensures that dribble bits one through seven will not cause a MAC to discard the frame due to a CRC error. (In 10 Mbps serial mode, all bits are simply passed across the interface unmodified.)

## 10.7 Transmit Polarity Control

The LXT973 Transceiver allows control over 10BASE-T transmit signal polarity for simplified integration. In combination with selectable MDI/MDIX mode and automatic polarity detection, this allows maximum flexibility in pinout definition. (Either of the twisted pairs may be transmit or receive, and either side of each twisted pair may be set to positive or negative.)

## 10.8 PHY Address

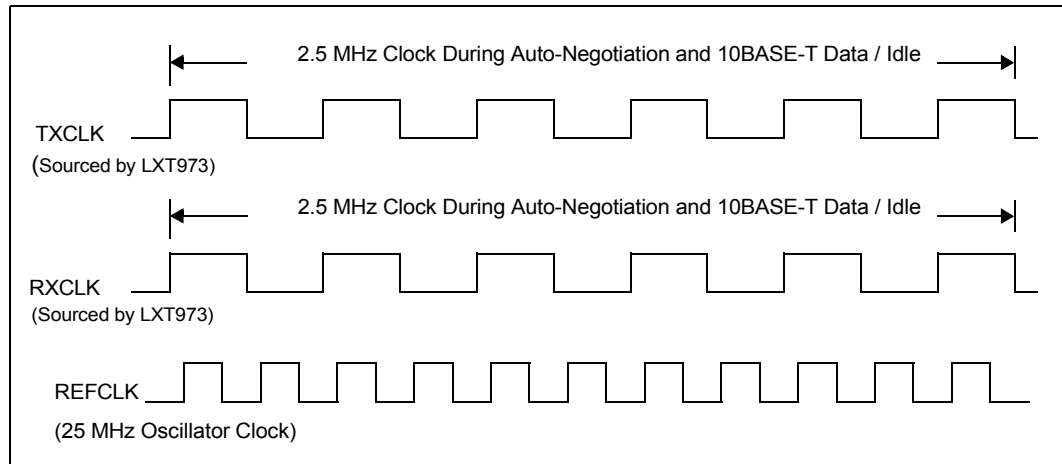
The LXT973 Transceiver provides four bits to set the PHY address. The least significant bit is fixed internally with Port 1 always being one address higher than Port 0.

## 11.0 Clock Generation

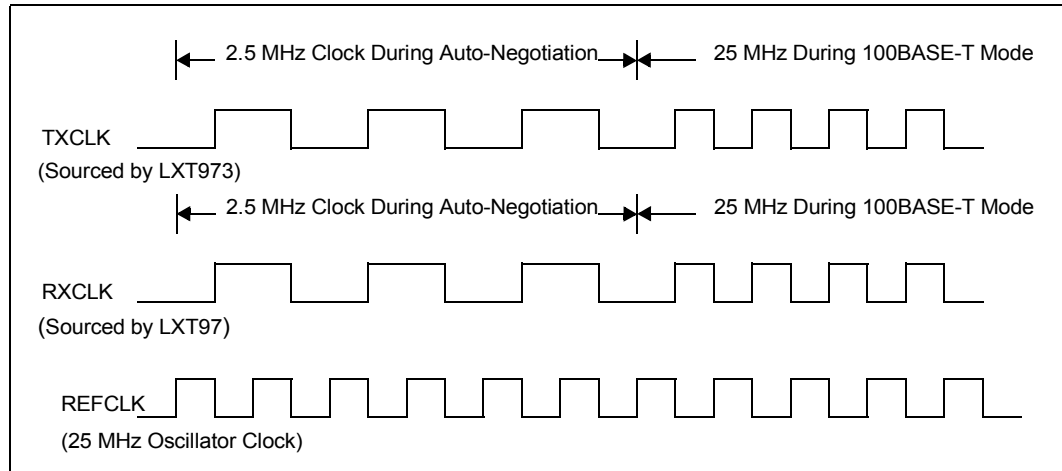
### 11.1 External Oscillator

Figure 25 through Figure 27 on page 64 illustrate the different frequencies of clock for 10BASE-T and 100BASE-TX in the LXT973 Transceiver.

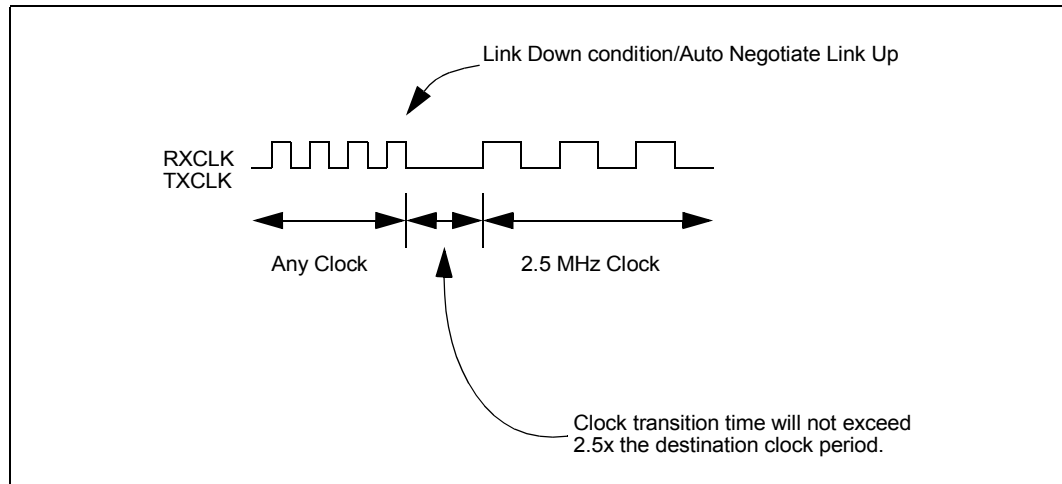
**Figure 25 MII 10BASE-T DTE Mode Auto-Negotiation**



**Figure 26 100BASE-T DTE Mode Auto-Negotiation**



**Figure 27 Link Down Clock Transition**





## 12.0 Register Definitions

The LXT973 Transceiver register set includes 16 registers per port. Refer to [Table 14](#) for a complete register listing.

Base Registers 0 through 8 are defined in accordance with the “Reconciliation Sublayer and Media Independent Interface” and “Physical Layer Link Signaling for 10/100 Mbps Auto-Negotiation” sections of the IEEE 802.3 specification.

Additional registers are defined in accordance with the IEEE 802.3 specification for adding unique chip functions.

**Table 14 Common Register Set**

Address	Register Name	Bit Definitions
0	Control Register	Refer to <a href="#">Table 16 on page 66</a>
1	Status Register	Refer to <a href="#">Table 17 on page 67</a>
2	PHY Identification Register 1	Refer to <a href="#">Table 18 on page 68</a>
3	PHY Identification Register 2	Refer to <a href="#">Table 19 on page 68</a>
4	Auto-Negotiation Advertisement Register	Refer to <a href="#">Table 20 on page 69</a>
5	Auto-Negotiation Link Partner Base Page Ability Register	Refer to <a href="#">Table 21 on page 70</a>
6	Auto-Negotiation Expansion Register	Refer to <a href="#">Table 22 on page 71</a>
7	Auto-Negotiation Next Page Transmit Register	Refer to <a href="#">Table 23 on page 72</a>
8	Auto-Negotiation Link Partner Received Next Page Register	Refer to <a href="#">Table 24 on page 72</a>
16	Port Configuration Register	Refer to <a href="#">Table 25 on page 73</a>
27	Special Function Register	Refer to <a href="#">Table 26 on page 74</a>

**Table 15 Register Bit Descriptions**

Bit Type	Description
R/W	Read and Write capable
RO	Read Only
WO	Write Only
AC	Auto Clear on Read
LHR	Latched from external pins on reset

**Table 16 Control Register (Address 0)**

Bit	Name	Description	Type <sup>1,2</sup>	Default
0.15	RESET	1 = PHY reset 0 = Normal operation	R/W AC	0 Note 2
0.14	Loopback	1 = Enable loopback mode 0 = Disable loopback mode	R/W	0
0.13	Speed Selection (LSB)	0.6 0.13 1 1 = Reserved 1 0 = 1000 Mbps (not allowed) 0 1 = 100 Mbps 0 0 = 10 Mbps	R/W	LHR Note 3
0.12	Auto-Negotiation Enable	1 = Enable Auto-Negotiation Process 0 = Disable Auto-Negotiation Process	R/W	LHR Note 3
0.11	Power-Down	1 = Power-Down 0 = Normal operation	R/W	0
0.10	Isolate	1 = Electrically isolate PHY from MII 0 = normal operation	R/W	0 Note 4
0.9	Restart Auto-Negotiation	1 = Restart Auto-Negotiation Process 0 = Normal operation	R/W AC	0
0.8	Duplex Mode	1 = Full-duplex 0 = Half-duplex	R/W	LHR Note 3
0.7	Collision Test	1 = Enable COL signal test 0 = Disable COL signal test	R/W	0
0.6	Speed Selection (MSB)	0.6 0.13 1 1 = Reserved 1 0 = 1000 Mbps (not allowed) 0 1 = 100 Mbps 0 0 = 10 Mbps	R/W	00
0.5:0	Reserved	Write as 0, ignore on Read	R/W	000000

1. Refer to [Table 15 on page 65](#) for Register Bit Descriptions.
2. During a hardware reset, all LHR information is latched in from the pins. During a software reset (Register bit 0.15), the LHR information is not re-read from the pins. This information reverts back to the information that was read in during the hardware reset. During a hardware reset, register information is unavailable for 1 ms after de-assertion of the reset. During a software reset (Register bit 0.15) the registers are available for reading. The reset bit should be polled to see when the part has completed reset.
3. LHR = Latched on Hardware Reset. Register bits 0.12, 0.13 and 0.8 are initialized based on the pin configuration value.
4. The Isolate function (Register bit 0.10) three-states all port MAC interface outputs. On the input side, TXEN and TXER are ignored.

**Table 17 Status Register (Address 1)**

Bit	Name	Description	Type <sup>1,2</sup>	Default
1.15	100BASE-T4	1 = PHY able to perform 100BASE-T4 0 = PHY not able to perform 100BASE-T4	RO	0
1.14	100BASE-X Full-Duplex	1 = PHY able to perform full-duplex 100BASE-X 0 = PHY not able to perform full-duplex 100BASE-X	RO	1
1.13	100BASE-X Half-Duplex	1 = PHY able to perform half-duplex 100BASE-X 0 = PHY not able to perform half-duplex 100BASE-X	RO	1
1.12	10 Mbps Full-Duplex	1 = PHY able to operate at 10 Mbps in full-duplex mode 0 = PHY not able to operate at 10 Mbps full-duplex mode	RO	1
1.11	10 Mbps Half-Duplex	1 = PHY able to operate at 10 Mbps in half-duplex mode 0 = PHY not able to operate at 10 Mbps in half-duplex	RO	1
1.10	100BASE-T2 Full-Duplex	1 = PHY able to perform full-duplex 100BASE-T2 0 = PHY not able to perform full-duplex 100BASE-T2	RO	0
1.9	100BASE-T2 Half-Duplex	1 = PHY able to perform half-duplex 100BASE-T2 0 = PHY not able to perform half-duplex 100BASE-T2	RO	0
1.8	Extended Status	1 = Extended status information in Register 15 0 = No extended status information in Register 15	RO	0
1.7	Reserved	0 = Write as 0, ignore on read	RO	0
1.6	MF Preamble Suppression	1 = PHY accepts management frames with preamble suppressed 0 = PHY will not accept management frames with preamble suppressed	RO	0
1.5	Auto-Negotiation complete	1 = Auto-Negotiation process completed 0 = Auto-Negotiation process not completed	RO	0
1.4	Remote Fault	1 = Remote fault condition detected 0 = No remote fault condition detected	RO/LH Note 2	0
1.3	Auto-Negotiation Ability	1 = PHY is able to perform Auto-Negotiation 0 = PHY is not able to perform Auto-Negotiation	RO	1
1.2	Link Status	1 = Link is up 0 = Link is down	RO/LL Note 2	0
1.1	Jabber Detect	1 = Jabber condition detected 0 = Jabber condition not detected	RO/LH Note 2	0
1.0	Extended Capability	1 = Extended register capabilities 0 = Basic register set capabilities only	RO	1

1. Refer to [Table 15 on page 65](#) for Register Bit Descriptions.  
 2. Bits that Latch High (LH) or Latch Low (LL) automatically clear when read.

**Table 18 PHY Identification Register 1 (Address 2)**

Bit	Name	Description	Type <sup>1</sup>	Default
2.15:0	PHY ID Number	The PHY identifier composed of bits 3 through 18 of the OUI	RO	0013

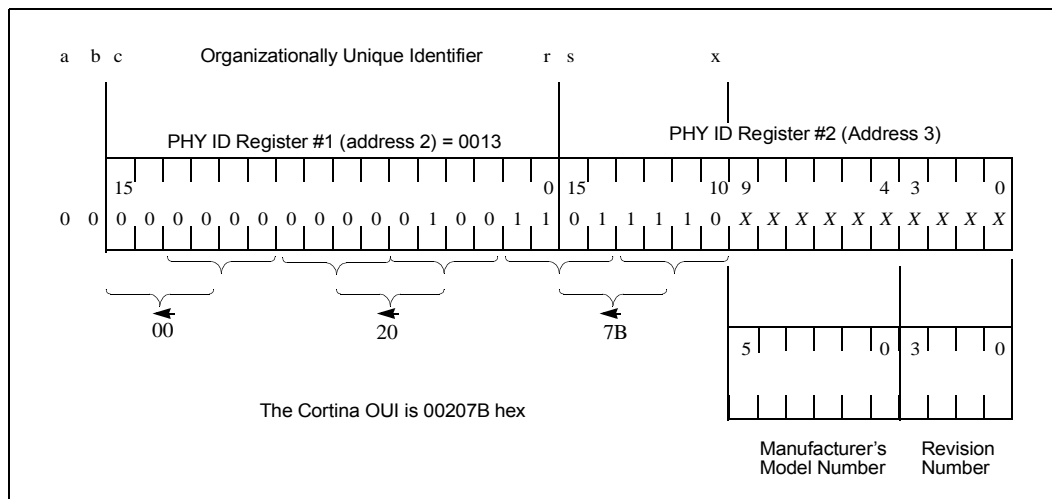
1. Refer to Table 15 on page 65 for Register Bit Descriptions.

**Table 19 PHY Identification Register 2 (Address 3)**

Bit	Name	Description	Type <sup>1</sup>	Default
3.15:10	PHY ID number	The PHY identifier composed of bits 19 through 24 of the OUI	RO	011110
3.9:4	Manufacturer's model number	6 bits containing manufacturer's part number	RO	100001
3.3:0	Manufacturer's revision number	4 bits containing manufacturer's revision number	RO	xxxx (See the LXT973 Transceiver Specification Update)

1. Refer to Table 15 on page 65 for Register Bit Descriptions.

**Figure 28 PHY Identifier Bit Mapping**



**Table 20 Auto-Negotiation Advertisement Register (Address 4)**

Bit	Name	Description	Type <sup>1</sup>	Default
4.15	Next Page	1 = PHY is capable of Next Page exchanges 0 = PHY is not capable of Next Page exchanges	R/W	0
4.14	Reserved	Write as 0, ignore on read	RO	0
4.13	Remote Fault	1 = Remote fault. 0 = No remote fault.	R/W	0
4.12	Reserved	Write as 0, ignore on read	R/W	0
4.11	Asymmetric Pause	Pause operation defined in Clause 40 and 27	R/W	0
4.10	Pause	Pause operation defined per IEEE 802.3x standard	R/W	0
4.9	100BASE-T4	1 = 100BASE-T4 capability is available. 0 = 100BASE-T4 capability is not available. (The LXT973 Transceiver does not support 100BASE-T4 but allows this bit to be set to advertise in the auto-negotiation sequence for 100BASE-T4 operation. An external 100BASE-T4 transceiver may be switched in, if this capability is desired.)	R/W	0
4.8	100BASE-TX Full-Duplex	1 = DTE is 100BASE-TX full-duplex capable. 0 = DTE is not 100BASE-TX full-duplex capable.	R/W	0 Note 2
4.7	100BASE-TX	1 = DTE is 100BASE-TX capable. 0 = DTE is not 100BASE-TX capable.	R/W	0 Note 2
4.6	10BASE-T Full-Duplex	1 = DTE is 10BASE-T full-duplex capable. 0 = DTE is not 10BASE-T full-duplex capable.	R/W	0 Note 2
4.5	10BASE-T	1 = DTE is 10BASE-T capable. 0 = DTE is not 10BASE-T capable.	R/W	0 Note 2
4.4:0	Selector Field, S<4:0>	<00001> = IEEE 802.3 <00010> = IEEE 802.9 ISLAN-16T <00000> = Reserved for future auto-negotiation development <11111> = Reserved for future auto-negotiation development Unspecified or reserved combinations should not be transmitted. <b>Note:</b> The selector field can be programmed to any value. In order for auto-negotiation to complete, the link partner's received selector field must match the value programmed in this register.	R/W	00001

1. Refer to [Table 15 on page 65](#) for Register Bit Descriptions.  
 2. Register bits 4.10 and 4.8:5 are initialized based on the pin configuration value.

**Table 21 Auto-Negotiation Link Partner Base Page Ability Register (Address 5)**

Bit	Name	Description	Type <sup>1</sup>	Default
5.15	Next Page	1 = Link Partner has ability to send multiple pages. 0 = Link Partner has no ability to send multiple pages.	RO	0
5.14	Acknowledge	1 = Link Partner has received Link Code Word from LXT973 Transceiver. 0 = Link Partner has not received Link Code Word from LXT973 Transceiver.	RO	0
5.13	Remote Fault	1 = Remote fault. 0 = No remote fault.	RO	0
5.12	Reserved	Write as 0, ignore on read.	RO	0
5.12:11	Asymmetric Pause	Pause operation defined in IEEE 802.3, Clauses 40 and 27	RO	0
5.10	Pause	Pause operation defined as of IEEE 802.3x	RO	0
5.9	100BASE-T4	1 = Link Partner is 100BASE-T4 capable. 0 = Link Partner is not 100BASE-T4 capable.	RO	0
5.8	100BASE-TX Full-Duplex	1 = Link Partner is 100BASE-TX full-duplex capable. 0 = Link Partner is not 100BASE-TX full-duplex capable.	RO	0
5.7	100BASE-TX	1 = Link Partner is 100BASE-TX capable. 0 = Link Partner is not 100BASE-TX capable.	RO	0
5.6	10BASE-T Full-Duplex	1 = Link Partner is 10BASE-T full-duplex capable. 0 = Link Partner is not 10BASE-T full-duplex capable.	RO	0
5.5	10BASE-T	1 = Link Partner is 10BASE-T capable. 0 = Link Partner is not 10BASE-T capable.	RO	0
5.4:0	Selector Field S[4:0]	<00001> = IEEE 802.3 <00010> = IEEE 802.9 ISLAN-16T <00000> = Reserved for future auto-negotiation development <11111> = Reserved for future a auto-negotiation development Unspecified or reserved combinations shall not be transmitted.	RO	00000

1. Refer to [Table 15 on page 65](#) for Register Bit Descriptions.  
**Note:** Per IEEE revised standard November 1997, this register is no longer used to store Link Partner Next Pages. Register 8 is now used for this purpose.

**Table 22 Auto-Negotiation Expansion Register (Address 6)**

Bit	Name	Description	Type <sup>1</sup>	Default
6.15:6	Reserved	Write as 0, ignore on read	RO	0
6.5	Base Page	This bit indicates the status of the auto-negotiation variable, Base Page. It also flags synchronization with the auto-negotiation state diagram, allowing detection of interrupted links. This bit is only used if Register bit 16.1 (Alternate Next Page feature) is set. 1 = base_page = true 0 = base_page = false	RO/LH Note 2	0
6.4	Parallel Detection Fault	1 = Parallel Detection Fault has occurred. 0 = Parallel Detection Fault has not occurred.	RO/LH Note 2	0
6.3	Link Partner Next Page Able	1 = Link partner is Next Page able. 0 = Link partner is not Next Page able.	RO	0
6.2	Next Page Able	1 = Local device is Next Page able 0 = Local device is not Next Page able	RO	1
6.1	Page Received	Indicates that a new page has been received and the received code word has been loaded into Register 5 (Base Pages) or Register 8 (Next Pages) as specified in clause 28 of IEEE 802.3. This bit is cleared on read. If Register bit 16.1 is set, the Page Received bit is also cleared when mr_page_rx = false, or transmit_disable = true.	RO/LH Note 2	0
6.0	Link Partner Auto-Neg Able	1 = Link partner is auto-negotiation able. 0 = Link partner is not auto-negotiation able.	RO	0
1. Refer to <a href="#">Table 15 on page 65</a> for Register Bit Descriptions. 2. Bits that Latch High (LH) or Latch Low (LL) automatically clear when read. <b>Note:</b> This table contains modifications that are selectable in Cortina PHYs. These modifications are used to ease the implementation of software Next Page. See separate Cortina tutorial/white-paper on the usage of Next Pages.				

**Table 23 Auto-Negotiation Next Page Transmit Register (Address 7)**

Bit	Name	Description	Type <sup>1</sup>	Default
7.15	Next Page (NP)	1 = Additional Next Pages follow 0 = Last page	R/W	0
7.14	Reserved	Write as 0, ignore on read	RO	0
7.13	Message Page (MP)	1 = Message Page 0 = Unformatted page	R/W	1
7.12	Acknowledge 2 (ACK2)	1 = Complies with message 0 = Does not comply with message	R/W	0
7.11	Toggle (T)	1 = Previous value of the transmitted Link Code Word was equal to logic zero 0 = Previous value of the transmitted Link Code Word was equal to logic one	R/W	0
7.10:0	Message/Unformatted Code Field	See Appendix C of the IEEE 802.3 standards for Next Page descriptions	R/W	00000000 001

1. Refer to [Table 15 on page 65](#) for Register Bit Descriptions.

**Table 24 Auto-Negotiation Link Partner Next Page Ability Register (Address 8)**

Bit	Name	Description	Type <sup>1</sup>	Default
8.15	Next Page (NP)	1 = Link Partner has additional Next Pages to send 0 = Link Partner has no additional Next Pages to send	RO	0
8.14	Acknowledge (ACK)	1 = Link Partner has received Link Code Word from LXT973 Transceiver 0 = Link Partner has not received Link Code Word from LXT973 Transceiver	RO	0
8.13	Message Page (MP)	1 = Page sent by the Link Partner is a Message Page 0 = Page sent by the Link Partner is an Unformatted Page	RO	0
8.12	Acknowledge 2 (ACK2)	1 = Link Partner complies with the message 0 = Link Partner cannot comply with the message	RO	0
8.11	Toggle (T)	1 = Previous value of the transmitted Link Code Word was equal to logic zero 0 = Previous value of the transmitted Link Code Word equalled logic one	RO	0
8.10:0	Message/Unformatted Code Field	See Appendix C of the IEEE 802.3 standards for Next Page descriptions	RO	00000000 000

1. Refer to [Table 15 on page 65](#) for Register Bit Descriptions.



**Table 25 Port Configuration Register (Address 16)**

Bit	Name	Description	Type <sup>1</sup>	Default
16.15	Reserved	Write as 0, ignore on read	R/W	0
16.14	Link Test Disable	1 = Force Link pass (sets appropriate registers and LEDs to pass) 0 = Normal operation	R/W	0
16.13	Transmit Disable	1 = Disable twisted-pair transmitter 0 = Normal operation	R/W	0
16.12	Bypass Scramble (100BASE-TX)	1 = Bypass Scrambler and De-scrambler 0 = Normal operation	R/W	0
16.11	Bypass 4B/5B (100BASE-TX)	1 = Bypass 4B/5B encoder and decoder 0 = Normal Operation	R/W	0
16.10	Jabber (10BASE-T)	1 = Disable Jabber 0 = Normal operation	R/W	0
16.9	SQE (10BASE-T)	1 = Enable Heart Beat 0 = Disable Heart Beat	R/W	0
16.8	TP Loopback (10BASE-T)	1 = Disable twisted-pair loopback during half-duplex operation 0 = Normal Operation - loopback in 10BASE-T, half-duplex	R/W	0
16.7	CRS Select (10BASE-T)	1 = CRS de-assert extends to RXDV de-assert 0 = Normal operation	R/W	1
16.6	Reserved	Write as 0, ignore on read	R/W	0
16.5	PRE_EN	Preamble Enable. 0 = Set RXDV High coincident with SFD 1 = Set RXDV High and RXD = preamble when CRS is asserted.	R/W	0
16.4	Reserved	Write as 0, ignore on read	R/W	0
16.3	10M Serial	1 = 10BASE_T serial mode. 10 Mbps data is driven serially on RXD<0> in this mode. 0 = Utilize normal MII mode-nibble.	R/W	0
16.2	Far End Fault Transmission Enable	1 = Enable Far End Fault transmission. 0 = Disable Far End Fault transmission.	R/W	1
16.1	Alternate NP Feature	1 = Enable Alternate auto-negotiation Next Page feature. 0 = Disable Alternate auto-negotiation Next Page feature.	R/W	0
16.0	Fiber Select	1 = Select fiber mode for this port. 0 = Select twisted-pair mode for this port.	R/W	LHR Note 2

1. Refer to [Table 15 on page 65](#) for Register Bit Descriptions.  
 2. Register bit 16.0 is latched in from FIBER\_TPn on hardware reset.

**Table 26 Special Function Register (Address 27)**

Bit	Name	Description	Type <sup>1</sup>	Default	
<b>Line Length Indication</b>					
27.15:13	Line Length Indicator	111 = Longest 110 = 101 = 100 = 011 = 010 = 001 = 000 = Shortest	Approximate line-length corresponding to each value will be determined at design verification (Not valid when agcset (Register bit 30.13 = 1)	RO	000
<b>Special Functions</b>					
27.12	Reserved	Write as 0, ignore on read	R/W	0	
27.11:10	Per-Port Rise time Control	00 = 3.3 ns (default pins TxSLEW<1:0>) 01 = 3.6 ns 10 = 3.9 ns 11 = 4.2 ns	R/W	LHR Note 2	
27.9	Auto MDIX enable	0 = Disable Auto-MDIX 1 = Enable Auto-MDIX	R/W	1	
27.8	Auto-MDIX	MDI/MDIX selection 0 = MDI, transmit on pair A and receive on pair B 1 = MDIX, transmit on pair B and receive on pair A	R/W	1	
27.7	Analog Loopback	1 = Enable Analog Loopback (transmits on twisted-pair) 0 = Disable Analog Loopback	R/W	0	
27.6	Loopback Detect Enable	1 = Enable automatic loopback detection. 0 = Disable automatic loopback detection	R/W	0	
27.5	Loopback Speed-Up Enable	1 = Enable automatic loopback detection speed-up 0 = Disable automatic loopback detection speed-up	R/W	0	
27.4	Loopback Detected	1 = Loopback detected 0 = No loopback detected	RO	0	
27.3:0	Reserved	Write as 0, ignore on read	R/W	00	
1. Refer to <a href="#">Table 15 on page 65</a> for Register Bit Descriptions. 2. Register bits 27.11:10 are latched in from hardware pins on hardware reset.					

## 13.0 Magnetics Information

The LXT973 Transceiver requires a 1:1 ratio for both the receive and transmit path. Refer to Table 30 for transformer requirements. Transformers meeting these requirements are available from various manufacturers. Designers should test and validate all magnetics before using them in production.

**Table 27 Magnetics Requirements**

Parameter	Min	Nom	Max	Units	Test Condition
Turns Ratio	–	1:1, 1:1	–	–	–
Insertion Loss	0.0	–	0.6	dB	–
Primary Inductance	350	–	–	μH	–
Transformer Isolation	2	–	–	kV	–
Differential to common mode rejection	40	–	–	dB	.1 to 60 MHz
	35	–	–	dB	60 to 100 MHz
Return Loss	17	–	–	dB	.1 to 60 MHz
	15	–	–	dB	60 to 100 MHz
Rise Time	2.0	–	3.5	ns	10% to 90%

## 14.0 Test Specifications

**Note:** Table 28 on page 76 through Table 51 on page 91 and Figure 29 on page 81 through Figure 42 on page 91 represent the performance specifications of the LXT973 Transceiver. These specifications are guaranteed by test except where noted “by design.” Minimum and maximum values listed in Table 30 on page 77 through Table 51 on page 91 apply over the recommended operating conditions specified in Table 29.

**Table 28 Absolute Maximum Ratings**

Parameter	Sym	Min	Max	Units
Supply Voltage <sup>1,2</sup>	VCCA, Vcc <sup>3</sup>	-0.3	3.0	V
	VCCPECL, VCCIO <sup>3</sup>	-0.3	4.0	V
Storage Temperature	TST	-65	+150	°C
<p><b>Caution:</b> Exceeding these values may cause permanent damage. Functional operation under these conditions is not implied. Exposure to maximum rating conditions for extended periods may affect device reliability.</p> <p>1. The voltage setting for VCCIO must be equal to or greater than the voltage setting for VCC core.            2. VCCIO and VCC core must be run at the same voltage extremes (for example, do not run VCCIO at maximum voltage and VCC core at minimum voltage).            3. VCCA = VccR plus VccT            Vcc = VccD (Digital Core)            VCCIO = Digital I/O Ring            VCCPECL = PECL supply for fiber</p>				

**Table 29 Operating Conditions (Sheet 1 of 2)**

Parameter	Sym	Min	Typ <sup>1</sup>	Max	Units	
Commercial Operating Temperature	TA	0	–	+70	°C	
Extended Operating Temperature	TA	-40		+85	°C	
Recommended Supply Voltage <sup>2</sup>	Analog & Digital	VCCA, Vcc <sup>3</sup>	2.38	2.5	2.63	V
	I/O @ 3.3 V	VCCIO <sup>3</sup>	3.14	3.3	3.45	V
	I/O @ 2.5 V	VCCIO <sup>3</sup>	2.38	2.5	2.63	V
	I/O @ 3.3 V	VCCPECL <sup>3</sup>	3.14	3.3	3.45	V
	I/O @ 2.5 V	VCCPECL <sup>3</sup>	2.38	2.5	2.63	V
V <sub>cc</sub> Current	100BASE-TX	I <sub>cc</sub>	–	–	150	mA
	10BASE-T	I <sub>cc</sub>	–	–	80	mA
<p>1. Typical values are at 25°C, and are for design aid only, are not guaranteed, and are not subject to production testing.            2. Voltages are with respect to ground unless otherwise specified.            3. VCCA = VccR plus VccT            Vcc = VccD (digital core)            VCCIO = digital I/O ring            VCCPECL = PECL supply for fiber</p>						

**Table 29 Operating Conditions (Sheet 2 of 2)**

Parameter		Sym	Min	Typ <sup>1</sup>	Max	Units
V <sub>CC</sub> Current	100BASE-FX	I <sub>CC</sub>			105	mA
	Power-Down Mode	I <sub>CC</sub>	–	–	12	mA
	Auto-Negotiation	I <sub>CC</sub>	–	–	85	mA

1. Typical values are at 25°C, and are for design aid only, are not guaranteed, and are not subject to production testing.  
 2. Voltages are with respect to ground unless otherwise specified.  
 3. V<sub>CCA</sub> = V<sub>CCR</sub> plus V<sub>CCT</sub>  
 V<sub>CC</sub> = V<sub>CCD</sub> (digital core)  
 V<sub>CCIO</sub> = digital I/O ring  
 V<sub>CCPECL</sub> = PECL supply for fiber

**Table 30 Digital Input/Output Characteristics<sup>2</sup>**

Parameter	Symbol	Min	Typ <sup>1</sup>	Max	Units	Test Conditions
Input Low voltage	V <sub>IL</sub>	–	–	0.8	V	–
Input High voltage	V <sub>IH</sub>	2.0	–	–	V	–
Input Current	I <sub>I</sub>	-10	–	10	μA	0.0 V <sub>I</sub> < V <sub>CC</sub>
Output Low voltage	V <sub>OL</sub>	–	–	0.4	V	I <sub>OL</sub> = 4 mA
Output High voltage	V <sub>OH</sub>	2.4	–	–	V	I <sub>OH</sub> = -4 mA

1. Typical values are at 25°C, and are for design aid only, are not guaranteed, and are not subject to production testing.  
 2. Applies to all pins except SD, MII, REFCLK, and LED pins. Refer to Table 32 for MII I/O Characteristics.

**Table 31 Digital Input/Output Characteristics - SD Pins**

Parameter	Symbol	Min	Typ <sup>1</sup>	Max	Units	Test Conditions
<b>2.5 V Operation<sup>2</sup></b>						
Input Low Voltage	V <sub>IL</sub>	0.69	0.8	1.03	V	V <sub>CCPECL</sub> = 2.5 V
Input High Voltage	V <sub>IH</sub>	1.34	1.6	1.62	V	V <sub>CCPECL</sub> = 2.5 V
<b>3.3 V Operation<sup>3</sup></b>						
Input Low Voltage	V <sub>IL</sub>	1.49	1.6	1.83	V	V <sub>CCPECL</sub> = 3.3 V
Input High Voltage	V <sub>IH</sub>	2.14	2.4	2.42	V	V <sub>CCPECL</sub> = 3.3 V

1. Typical values are at 25°C, and are for design aid only, are not guaranteed, and are not subject to production testing.  
 2. For 2.5 V operation, SD\_2P5V = V<sub>CCPECL</sub> and V<sub>CCPECL</sub>=2.5 V.  
 3. For 3.3 V operation, SD\_2P5V = GNDPECL or Floating and V<sub>CCPECL</sub>=3.3 V.

**Table 32 Digital Input/Output Characteristics - MII Pins**

Parameter	Symbol	Min	Typ <sup>1</sup>	Max	Units	Test Conditions
Input Low voltage	V <sub>IL</sub>	–	–	0.8	V	–
Input High voltage	V <sub>IH</sub>	2.0	–	–	V	–
Input Current	I <sub>I</sub>	-10	–	10	μA	0.0 V <sub>I</sub> < V <sub>CC</sub>
Output Low voltage	V <sub>OL</sub>	–	–	0.4	V	I <sub>OL</sub> = 4 mA
Output High voltage	V <sub>OH</sub>	2.4	–	–	V	I <sub>OH</sub> = -4 mA, V <sub>CCIO</sub> = 3.3 V
	V <sub>OH</sub>	2.0	–	–	V	I <sub>OH</sub> = -4 mA, V <sub>CCIO</sub> = 2.5 V

1. Typical values are at 25°C, and are for design aid only, are not guaranteed, and are not subject to production testing.  
 2. Parameter is guaranteed by design and not subject to production testing.

**Table 33 REFCLK Characteristics**

Parameter	Symbol	Min	Typ <sup>1</sup>	Max	Units	Test Conditions
Input Low voltage	V <sub>IL</sub>	–	–	0.8	V	–
Input High voltage	V <sub>IH</sub>	2.0	–	–	V	–
Input Clock Frequency Tolerance <sup>2</sup>	Δf	–	–	±50	ppm	–
Input Clock Duty Cycle <sup>2</sup>	T <sub>dc</sub>	40	–	60	%	–
Input Capacitance <sup>2</sup>	C <sub>IN</sub>	–	3.0	–	pF	–

1. Typical values are at 25°C, and are for design aid only, are not guaranteed, and are not subject to production testing.  
 2. Parameter is guaranteed by design: not subject to production testing.

**Table 34 LED Pin Characteristics**

Parameter	Symbol	Min	Typ <sup>1</sup>	Max	Units	Test Conditions
Output Low Voltage	V <sub>OL</sub>	–	–	0.4	V	I <sub>OL</sub> = 10 mA
Output High Current	I <sub>OH</sub>	–	–	10	μA	V <sub>OH</sub> = V <sub>CC</sub> max
Input Leakage Current	I <sub>I</sub>	-10	–	10	μA	0 V <sub>I</sub> < V <sub>CCIO</sub>

1. Typical values are at 25°C, and are for design aid only, are not guaranteed, and are not subject to production testing.

**Table 35 100BASE-TX Transceiver Characteristics**

Parameter	Sym	Min	Typ <sup>1</sup>	Max	Units	Test Conditions
Peak differential output voltage	VP	0.95	1.0	1.05	V	Note 2
Signal amplitude symmetry	Vss	98	100	102	%	Note 2
Signal rise/fall time	TRF	3.0	3.5	5.0	ns	Note 2
Rise/fall time symmetry	TRFS	–	.25	0.5	ns	Note 2
Duty cycle distortion	DCD	35	50	65	%	Offset from 16 ns pulse width at 50% of pulse peak
Overshoot/Undershoot	Vos	–	–	5	%	–
Jitter (measured differentially)	–	–	0.75	1.4	ns	–

1. Typical values are at 25°C, and are for design aid only, are not guaranteed, and are not subject to production testing.  
 2. Measured at the line side of the transformer, line replaced by 100Ω (+/-1%) resistor.

**Table 36 10BASE-T Transceiver Characteristics**

Parameter	Sym	Min	Typ <sup>1</sup>	Max	Units	Test Conditions
<b>Transmitter</b>						
Peak differential output voltage	VOP	2.2	2.5	2.8	V	Note 2
Jitter magnitude added by the MAU and PLS sections <sup>3, 4</sup>	t <sub>bx-jit</sub>	–	3.2	11	ns	–
<b>Receiver</b>						
Differential squelch threshold	VDS	300	500	585	mV Peak	5 MHz square wave input

1. Typical values are at 25°C and are for design aid only, are not guaranteed, and are not subject to production testing.  
 2. Parameter is guaranteed by design; not subject to production testing.  
 3. IEEE 802.3 specifies maximum jitter addition at 1.5 ns for the AUI cable, 0.5 ns from the encoder, and 3.5 ns from the MAU.  
 4. After line model specified by IEEE 802.3 for 10BASE-T MAU.

**Table 37 100BASE-FX Transceiver Characteristics**

Parameter	Sym	Min	Typ <sup>1</sup>	Max	Units	Test Conditions
<b>Transmitter</b>						
Peak-to-peak differential output voltage	V <sub>DIFF-P</sub>	0.6	1.3	1.5	V	–
Signal rise/fall time	T <sub>RF</sub>	–	1.2	1.9	ns	20% <-> 80 % 2.0 pF load
Jitter (measured differentially)	–	–	0.5	1.4	ns	–
<b>Receiver</b>						
Peak differential input voltage	V <sub>IP</sub>	0.55	–	1.5	V	–
Common mode input range	V <sub>CMIR</sub>	–	–	V <sub>CC</sub> - 0.7	V	–
1. Typical values are at 25°C, and are for design aid only, are not guaranteed, and are not subject to production testing.						

**Table 38 10BASE-T Link Integrity Timing Characteristics**

Parameter	Sym	Min	Typ <sup>1</sup>	Max	Units	Test Conditions
Time Link Loss Receive	TLL	50	–	150	ms	–
Link Detection	TLP	2	–	7	Link Pulses	–
Link Min Receive Timer	TLR MIN	2	–	7	ms	–
Link Max Receive Timer	TLR MAX	50	–	150	ms	–
Link Transmit Period	Tlt	8	–	24	ms	–
Link Pulse Width	Tlpw	60	114	150	ns	–
1. Typical values are at 25°C, and are for design aid only, are not guaranteed, and are not subject to production testing.						

**Table 39 Twisted-Pair Pins**

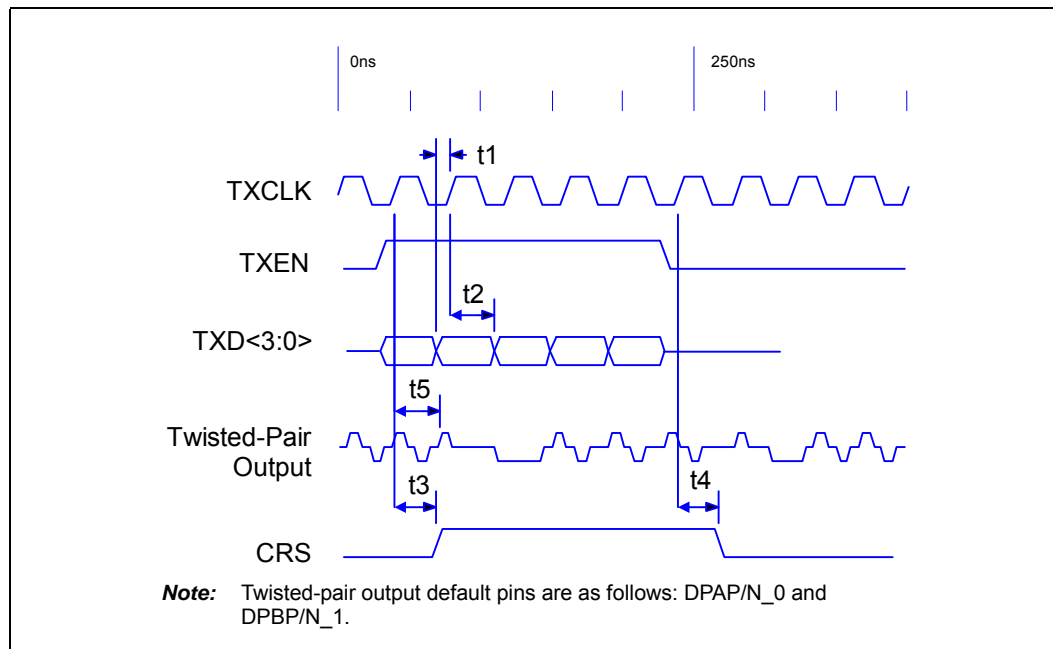
Parameter	Sym	Min	Typ <sup>1</sup>	Max	Units	Test Conditions
Receive input impedance <sup>2</sup>	Z <sub>IN</sub>	–	100	–	Ω	Between RX+ and RX-
Driver output impedance <sup>2</sup> (Line driver output enabled)	R <sub>O</sub>	–	100	–	Ω	Between TX+ and TX-
1. Typical values are at 25°C and are for design aid only, are not guaranteed, and are not subject to production testing. 2. Parameter is guaranteed by design; not subject to production testing.						



## 15.0 Timing Diagrams

The LXT973 Transceiver device meets all timings for MII per the IEEE 802.3u standard. Figure 29 through Figure 34 on page 86 refer to MII timings.

**Figure 29 100BASE-TX Transmit Timing - 4B Mode**

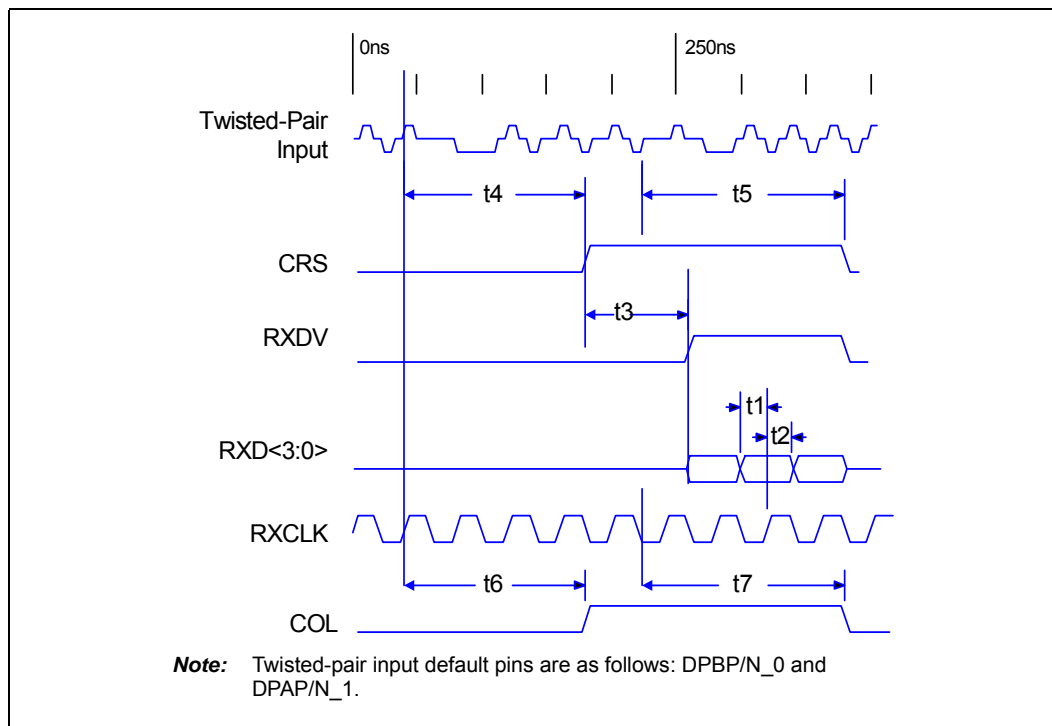


**Table 40 MII - 100BASE-TX Transmit Timing Parameters - 4B Mode**

Parameter	Sym	Min	Typ <sup>1</sup>	Max	Units	Test Conditions
TXD<3:0>, TXEN, TXER setup to TXCLK High	t1	12	–	–	ns	–
TXD<3:0>, TXEN, TXER hold from TXCLK High	t2	0	–	–	ns	–
TXEN sampled to CRS asserted	t3	2	4	5	BT	–
TXEN sampled to CRS de-asserted	t4	2	4	5	BT	–
TXEN sampled to twisted-pair output (Tx latency)	t5	–	5	–	BT	–

1. Typical values are at 25°C, and are for design aid only, are not guaranteed, and are not subject to production testing.

**Figure 30 100BASE-TX Receive Timing - 4B Mode**

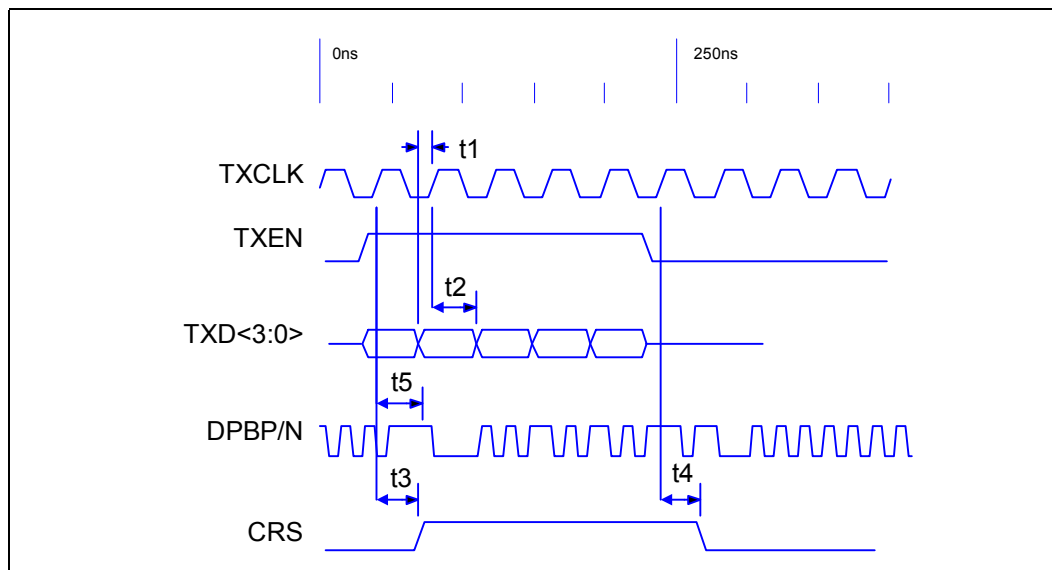


**Table 41 MII - 100BASE-TX Receive Timing Parameters - 4B Mode**

Parameter	Sym	Min	Typ <sup>1</sup>	Max	Units	Test Conditions
RXD<3:0>, RXDV, RXER setup to RXCLK High	t1	10	–	–	ns	–
RXD<3:0>, RXDV, RXER hold from RXCLK High	t2	10	–	–	ns	–
CRS asserted to RXD<3:0>, RXDV	t3	3	4	5	BT	–
Receive start of “J” to CRS asserted	t4	11	–	16	BT	–
Receive start of “T” to CRS de-asserted	t5	10	14	17	BT	–
Receive start of “J” to COL asserted	t6	10	–	15	BT	–
Receive start of “T” to COL de-asserted	t7	14	17	20	BT	–

1. Typical values are at 25°C, and are for design aid only, are not guaranteed, and are not subject to production testing.

**Figure 31 100BASE-FX Transmit Timing**

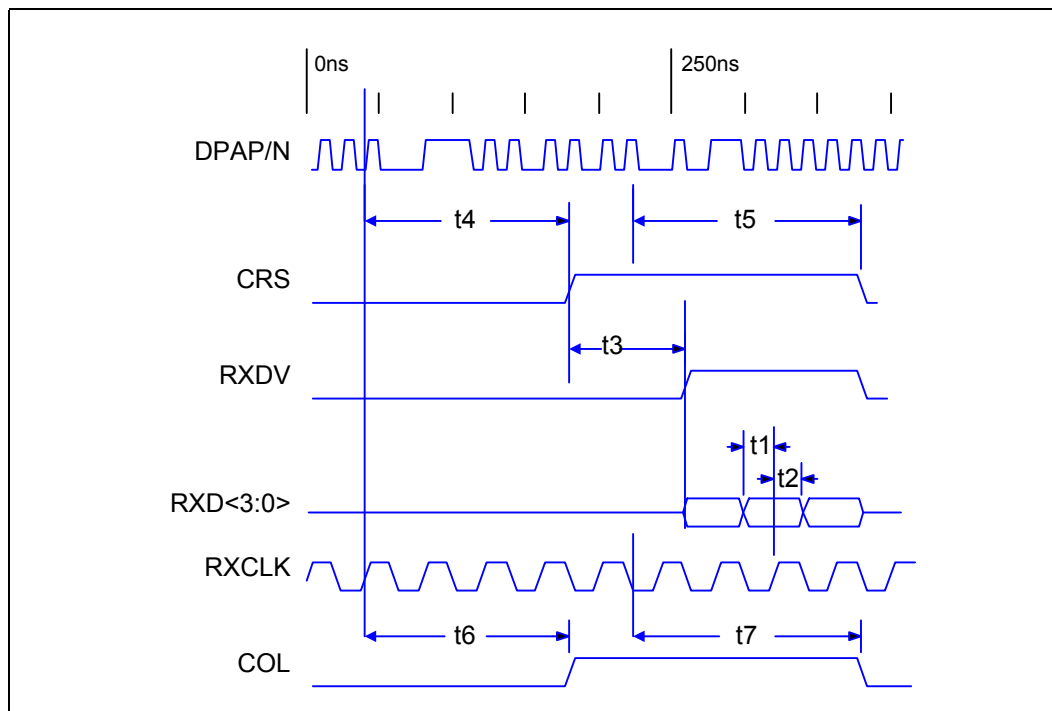


**Table 42 100BASE-FX Transmit Timing Parameters**

Parameter	Sym	Min	Typ <sup>1</sup>	Max	Units	Test Conditions
TXD<3:0>, TXEN, TXER setup to TXCLK High	t1	12	–	–	ns	–
TXD<3:0>, TXEN, TXER hold from TXCLK High	t2	0	–	–	ns	–
TXEN sampled to CRS asserted	t3	2	–	5	BT	–
TXEN sampled to CRS de-asserted	t4	1	–	5	BT	–
TXEN sampled to fiber output (Tx latency)	t5	–	4	–	BT	–

1. Typical values are at 25°C, and are for design aid only, are not guaranteed, and are not subject to production testing.

**Figure 32 100BASE-FX Receive Timing**

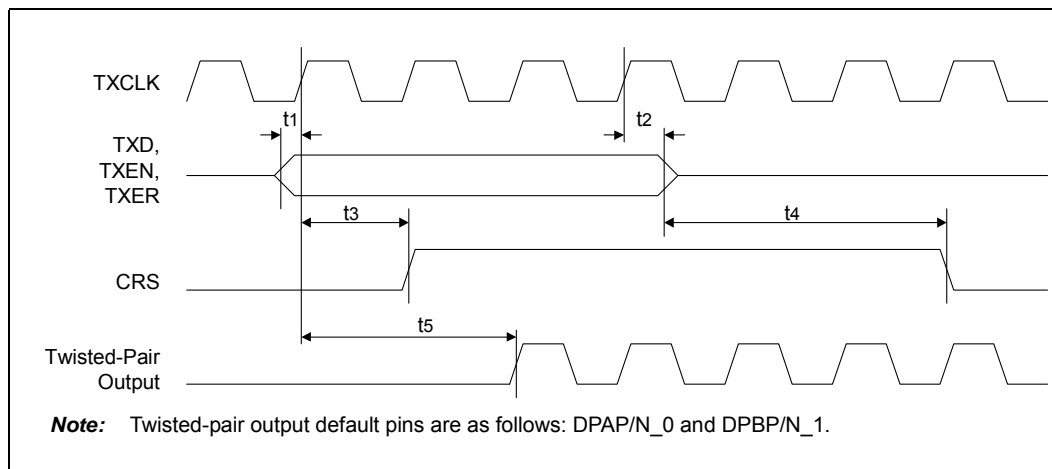


**Table 43 100BASE-FX Receive Timing Parameters**

Parameter	Sym	Min	Typ <sup>1</sup>	Max	Units	Test Conditions
RXD<3:0>, RXDV, RXER setup to RXCLK High	t1	10	–	–	ns	–
RXD<3:0>, RXDV, RXER hold from RXCLK High	t2	10	–	–	ns	–
CRS asserted to RXD<3:0>, RXDV	t3	3	–	5	BT	–
Receive start of “J” to CRS asserted	t4	9	–	14	BT	–
Receive start of “T” to CRS deasserted	t5	13	–	17	BT	–
Receive start of “J” to COL asserted	t6	10	–	14	BT	–
Receive start of “T” to COL deasserted	t7	13	–	18	BT	–

1. Typical values are at 25°C, and are for design aid only, are not guaranteed, and are not subject to production testing.

**Figure 33 10BASE-T Transmit Timing (Parallel Mode)**

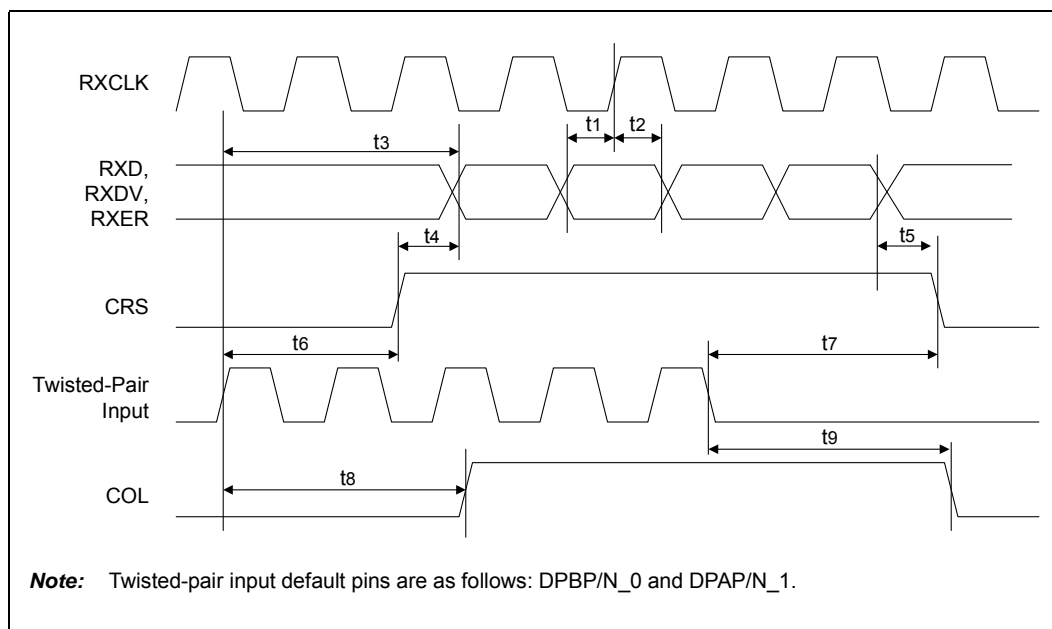


**Table 44 MII - 10BASE-T Transmit Timing Parameters (Parallel Mode)**

Parameter	Sym	Min	Typ <sup>1</sup>	Max	Units	Test Conditions
TXD, TXEN, TXER setup to TXCLK High	t1	10	–	–	ns	–
TXD, TXEN, TXER hold from TXCLK High	t2	0	–	–	ns	–
TXEN sampled to CRS asserted	t3	–	5.5	–	BT	–
TXEN sampled to CRS de-asserted	t4	–	5	–	BT	–
TXEN sampled to twisted-pair output (Tx latency)	t5	–	575	–	ns	–

1. Typical values are at 25°C, and are for design aid only, are not guaranteed, and are not subject to production testing.

**Figure 34 10BASE-T Receive Timing (Parallel Mode)**

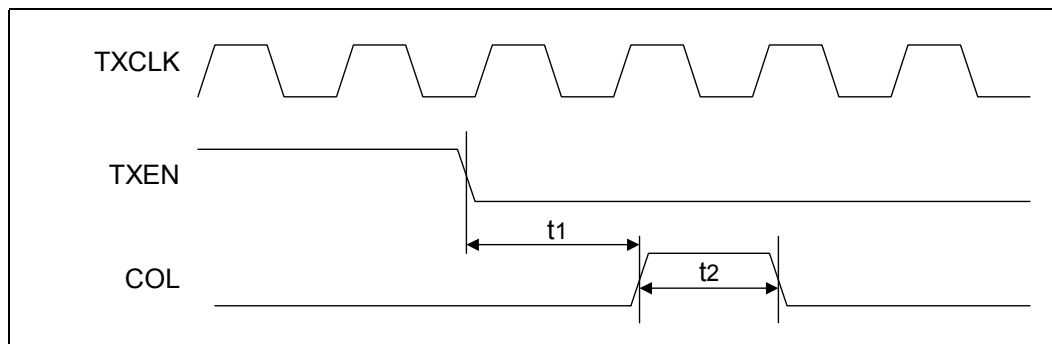


**Table 45 MII - 10BASE-T Receive Timing Parameters (Parallel Mode)**

Parameter	Sym	Min	Typ <sup>1</sup>	Max	Units	Test Conditions
RXD, RXDV, RXER setup to RXCLK High	t1	10	–	–	ns	–
RXD, RXDV, RXER hold from RXCLK High	t2	10	–	–	ns	–
Twisted-pair input to RXD out (Rx latency)	t3	–	64	–	BT	–
CRS asserted to RXD, RXDV, RXER asserted <sup>2</sup>	t4	–	62	–	BT	–
RXD, RXDV, RXER de-asserted to CRS de-asserted <sup>3</sup>	t5	–	0.5	–	BT	–
Twisted-pair input to CRS asserted	t6	–	4	–	BT	–
Twisted-pair input quiet to CRS de-asserted	t7	–	4	–	BT	–
Twisted-pair input to COL asserted	t8	–	4	–	BT	–
Twisted-pair input quiet to COL de-asserted	t9	–	4	–	BT	–

1. Typical values are at 25°C, and are for design aid only, are not guaranteed, and are not subject to production testing.  
 2. CRS is asserted. RXD/RXDV are driven at the start of SFD (64 BT) unless Register bit 16.5 is set.  
 3. If Register bit 16.7 is set, CRS extends to RXDV de-assert.

**Figure 35 10BASE-T SQE (Heartbeat) Timing**

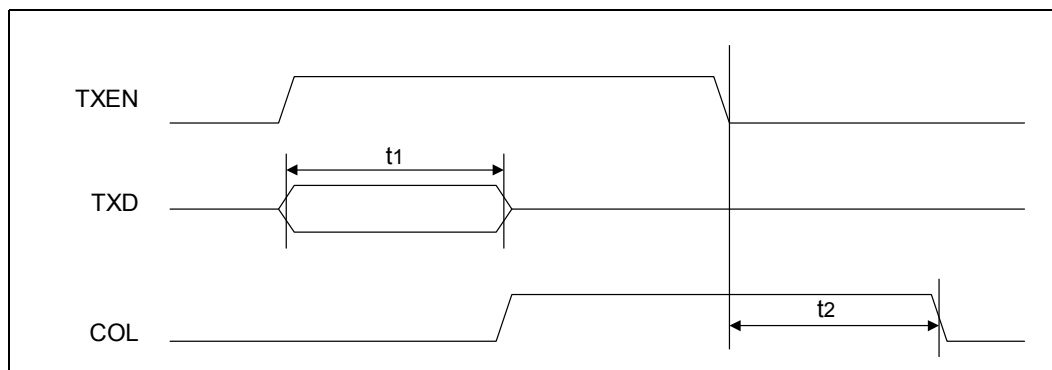


**Table 46 10BASE-T SQE (Heartbeat) Timing Parameters**

Parameter	Sym	Min	Typ <sup>1</sup>	Max	Units	Test Conditions
COL (SQE) delay after TXEN de-asserted	t1	0.65	1.2	1.6	μs	–
COL (SQE) pulse duration	t2	0.5	.95	1.5	μs	–

1. Typical values are at 25°C, and are for design aid only, are not guaranteed, and are not subject to production testing.

**Figure 36 10BASE-T Jab and Unjab Timing**

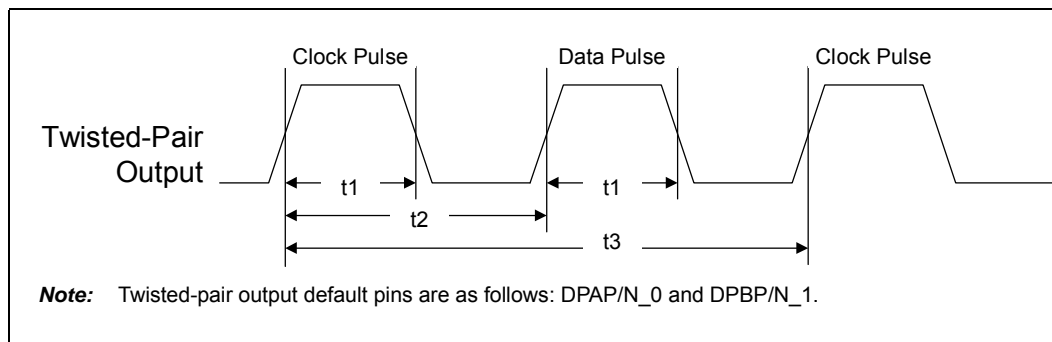


**Table 47 10BASE-T Jab and Unjab Timing Parameters**

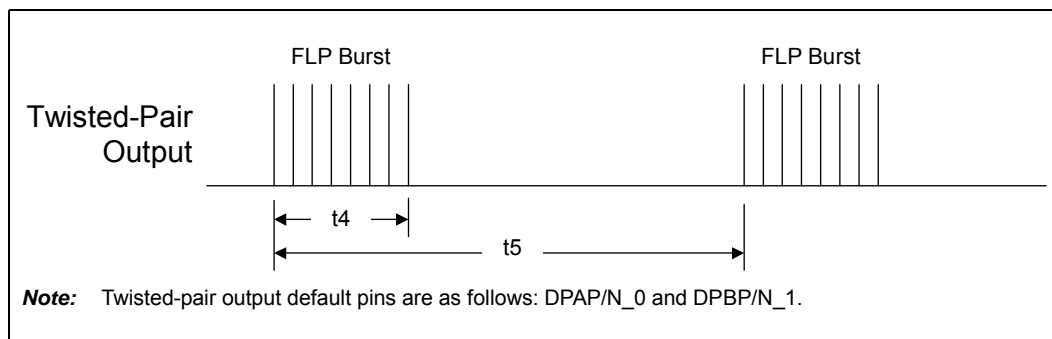
Parameter	Sym	Min	Typ <sup>1</sup>	Max	Units	Test Conditions
Maximum transmit time	t1	20	–	150	ms	–
Unjab time	t2	250	–	750	ms	–

1. Typical values are at 25°C, and are for design aid only, are not guaranteed, and are not subject to production testing.

**Figure 37 Fast Link Pulse Timing**



**Figure 38 FLP Burst Timing**



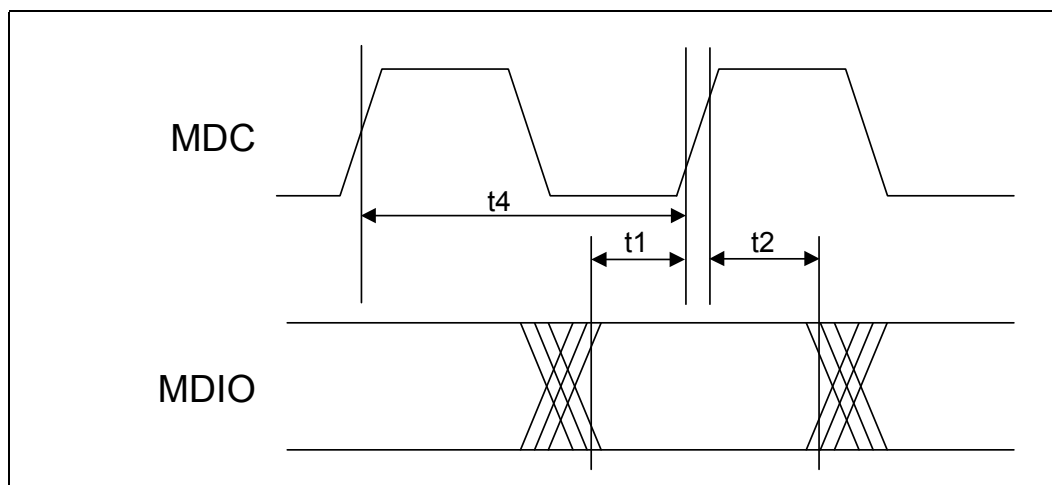
**Table 48 Fast Link Pulse Timing Parameters**

Parameter	Sym	Min	Typ <sup>1</sup>	Max	Units	Test Conditions
Clock/Data pulse width	t1	115	116	118	ns	–
Clock pulse to Data pulse	t2	55.5	63	69.5	μs	–
Clock pulse to Clock pulse	t3	111	126	139	μs	–
FLP burst width	t4	–	2.0	–	ms	–
FLP burst to FLP burst	t5	8	10	24	ms	–
Clock/Data pulses per burst	–	17	–	33	ea	–

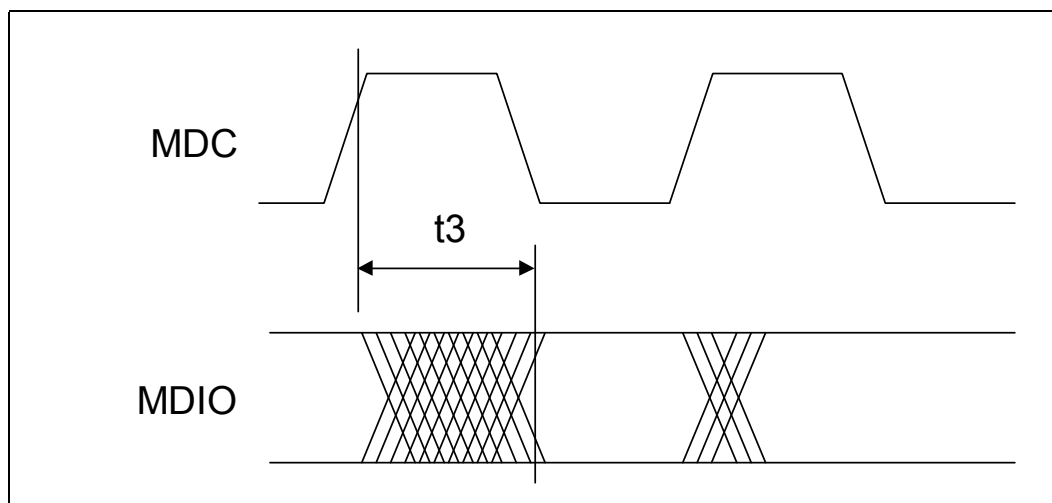
1. Typical values are at 25°C, and are for design aid only, are not guaranteed, and are not subject to production testing.



**Figure 39 MDIO Input Timing**



**Figure 40 MDIO Output Timing**



**Table 49 MDIO Timing Parameters (Sheet 1 of 2)**

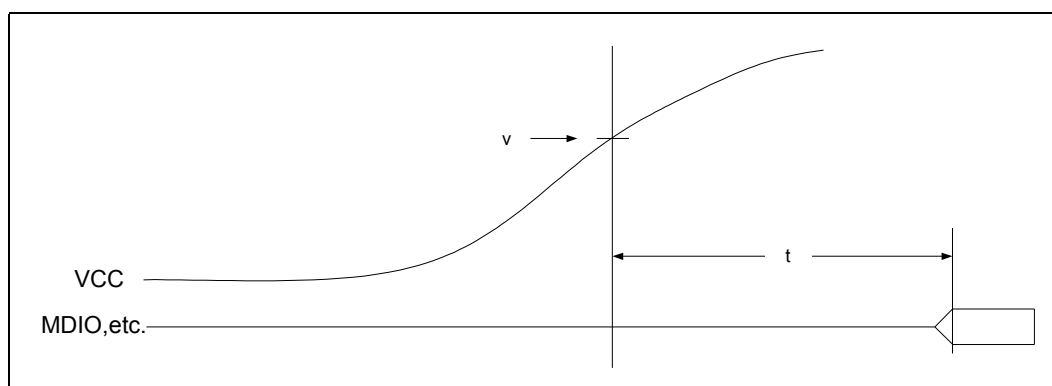
Parameter	Sym	Min	Typ <sup>1</sup>	Max	Units	Test Conditions
MDIO setup before MDC	t1	10	–	–	ns	When sourced by STA
1. Typical values are at 25°C, and are for design aid only, are not guaranteed, and are not subject to production testing. 2. When operated at 2.5 MHz.						

**Table 49 MDIO Timing Parameters (Sheet 2 of 2)**

Parameter	Sym	Min	Typ <sup>1</sup>	Max	Units	Test Conditions
MDIO hold after MDC	t2	10	–	–	ns	When sourced by STA
MDC to MDIO output delay	t3	10	–	300 <sup>2</sup>	ns	When sourced by PHY
MDC Clock Speed	t4	–	–	20	MHz	–

1. Typical values are at 25°C, and are for design aid only, are not guaranteed, and are not subject to production testing.  
 2. When operated at 2.5 MHz.

**Figure 41 Power-Up Timing**

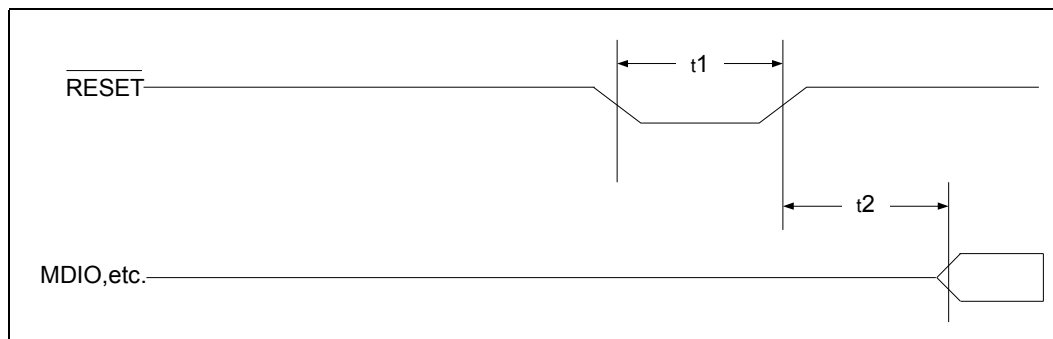


**Table 50 Power-Up Timing Parameters**

Parameter	Sym	Min	Typ <sup>1</sup>	Max	Units	Test Conditions
Voltage threshold	v1	2.9	–	–	V	–
Power-up delay <sup>2</sup>	t1	–	–	300	μs	–

1. Typical values are at 25°C and are for design aid only; not guaranteed and not subject to producing testing.  
 2. Power-up delay is specified as a maximum value because it refers to the guaranteed performance of the PHY. The PHY comes out of reset after a delay of **no more than** 300 μs. System designers should consider this as a minimum value. After threshold v1 is reached, the MAC should delay **no less than** 300 μs before accessing the MDIO port.

**Figure 42** RESET Pulse Width and Recovery Timing



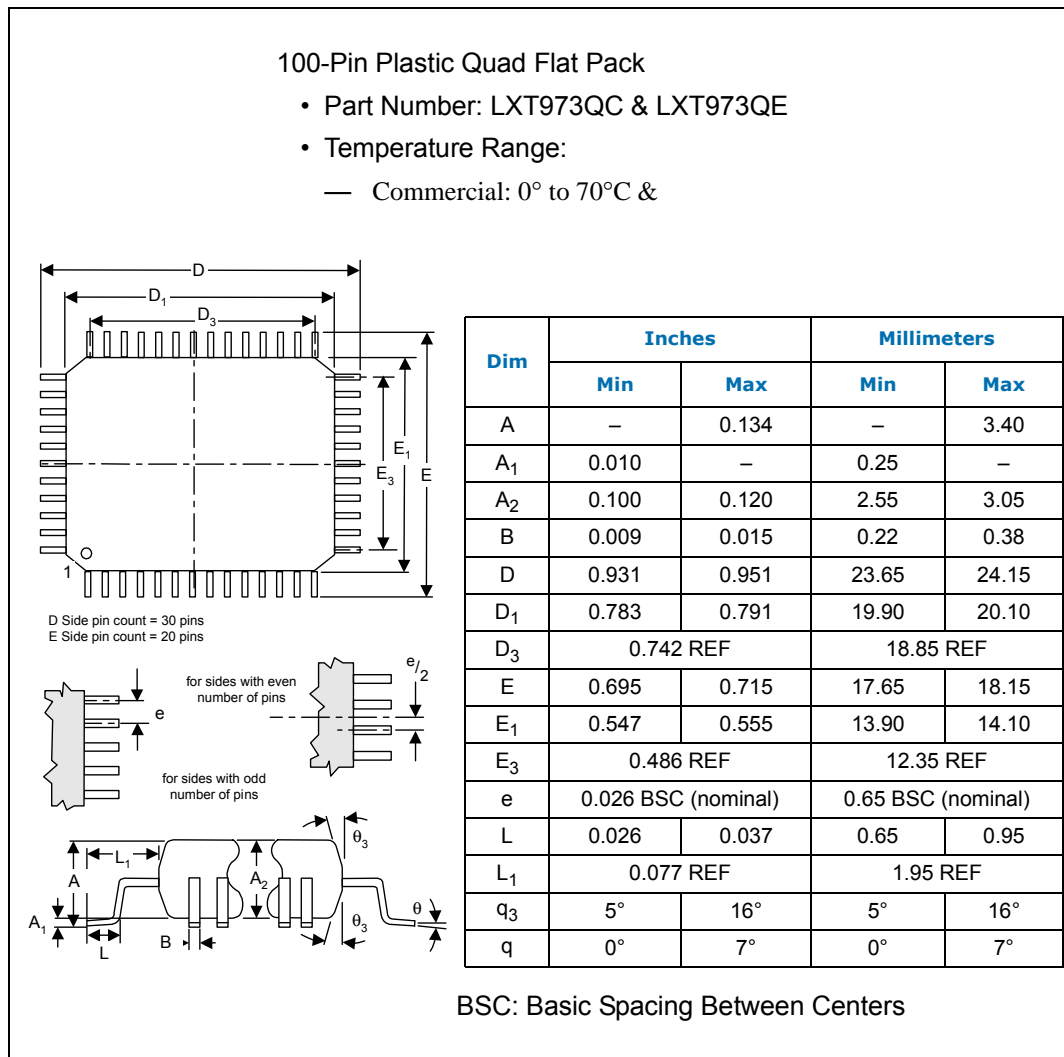
**Table 51** RESET Pulse Width and Recovery Timing Parameters

Parameter	Sym	Min	Typ <sup>1</sup>	Max	Units	Test Conditions
RESET pulse width	t1	10	–	–	ns	–
RESET recovery delay <sup>2</sup>	t2	–	–	300	μs	–

1. Typical values are at 25°C and are for design aid only; not guaranteed and not subject to producing testing.  
 2. Reset recovery delay is specified as a maximum value because it refers to the PHY's guaranteed performance. - the PHY comes out of reset after a delay of **no more than 300 μs**. System designers should consider this as a minimum value. After de-asserting RESET, the MAC should delay **no less than 300 μs** before accessing the MDIO port.

## 16.0 Mechanical Specifications

**Figure 43 Mechanical Specifications**



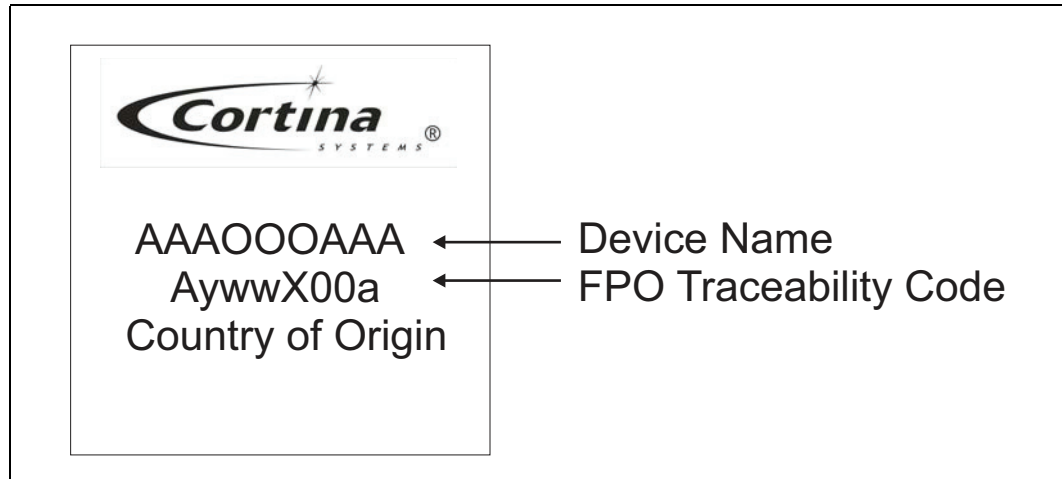
### 16.1 Top Label Marking

Figure 45 shows a sample PQFP package for the LXT973 Transceiver.

**Notes:**

1. In contrast to the Pb-Free (RoHS-compliant) PQFP package, the non-RoHS-compliant packages do not have the “e3” symbol in the last line of the package label.
2. Further information regarding RoHS and lead-free components can be obtained from your local Cortina representative.

**Figure 44** Example of Top Marking Information Labeled as Cortina Systems, Inc.



**Figure 45** Sample PQFP Package (marked as Intel\*) – LXT973QC Transceiver

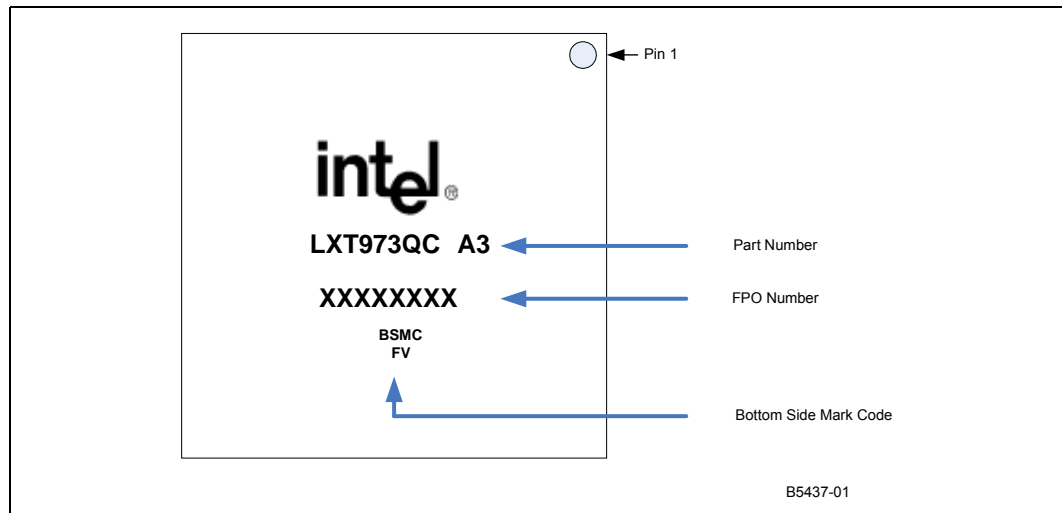
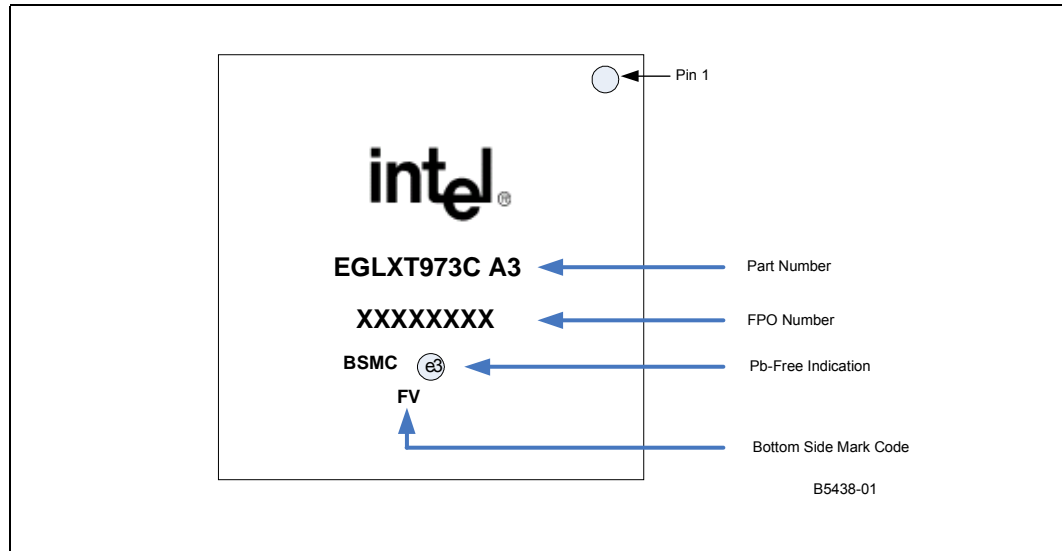


Figure 46 shows a sample Pb-free RoHS-compliant PQFP package for the LXT973 Transceiver.

**Figure 46** Sample Pb-Free (RoHS-Compliant) PQFP Package (marked as Intel\*) – Intel\* EGLX973QC Transceiver



---

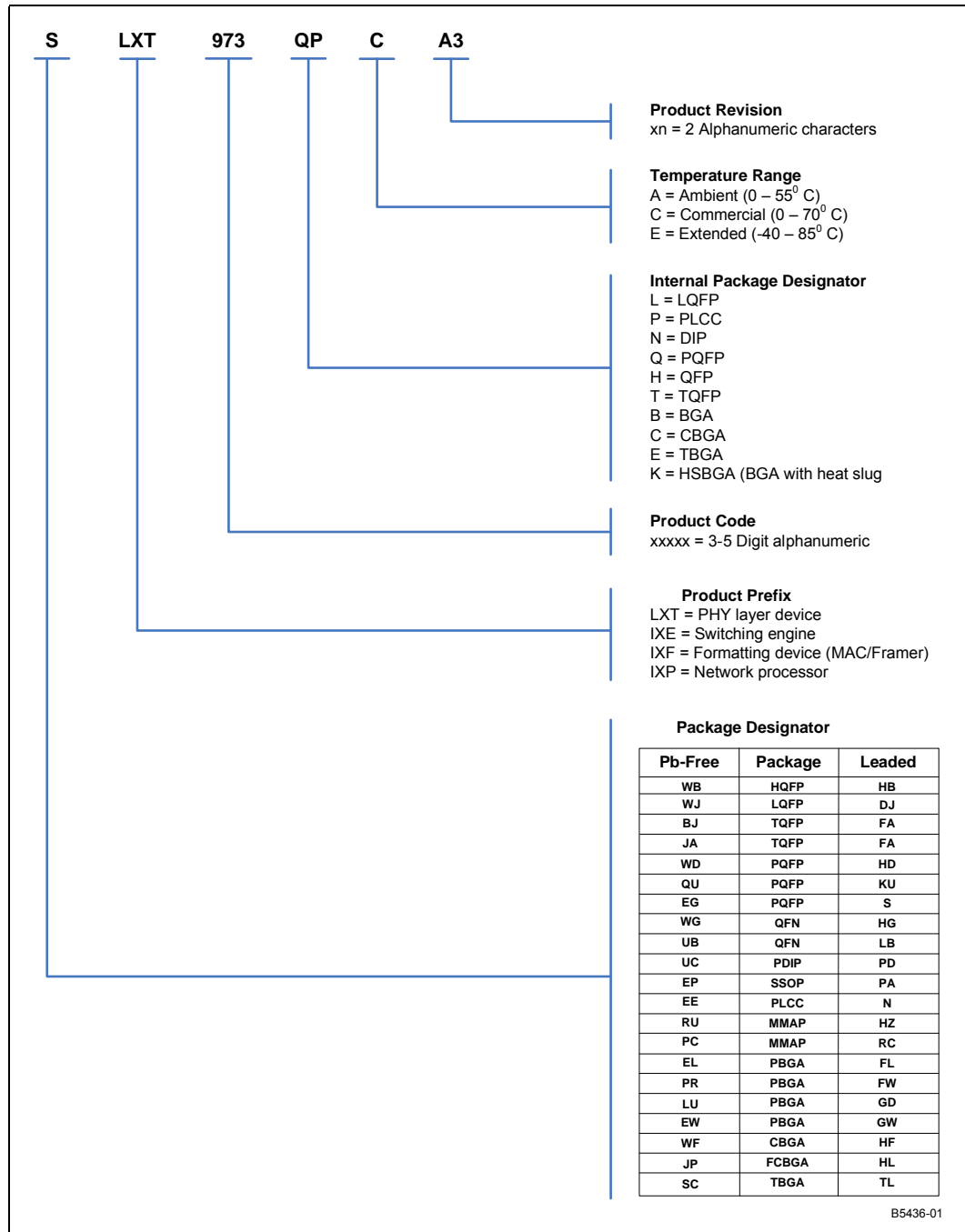
## 17.0 Product Ordering Information

Table 52 lists the LXT973 Transceiver product ordering information. Figure 47 provides the ordering information matrix.

**Table 52 Product Ordering Information**

Number	Revision	Package Type	Pin Count	RoHS Compliant
SLXT973QC.A3V	A3	PQFP	100	No
EGLXT973QC.A3V	A3	PQFP	100	Yes
SLXT973QE.A3V	A3	PQFP	100	No
EGLXT973QE.A3V	A3	PQFP	100	Yes

**Figure 47 Ordering Information – Sample**







**For additional product and ordering information:**

[www.cortina-systems.com](http://www.cortina-systems.com)

---

~ End of Document ~