



## V.90, V.34, V.32BIS, V.22BIS ISOMODEM<sup>®</sup> WITH GLOBAL DAA

### Features

- Data modem formats
  - ITU-T, Bell
  - 300 bps up to 56 kbps
  - V.21, V.22, V.29 Fast Connect
  - V.42, V.42bis, MNP2-5
  - Automatic rate negotiation
- Type I and II caller ID decode
- No external ROM or RAM required
- UART or parallel interface
- AT command set support
- SMS / MMS support
- Integrated DAA
  - Over 6000 V Capacitive isolation
  - Parallel phone detect
  - Globally-compliant line interface
  - Overcurrent detection
- 27 MHz clock input
- Single 3.3 V power supply
- Firmware upgradeable
- EEPROM interface
- Pb-free, RoHS Compliant Packages
- Commercial or industrial temperature range

### Applications

- Set-top boxes
- Point-of-sale terminals
- Text/video telephones
- Digital video recorder
- Digital televisions
- Remote monitoring

### Description

The ISOModem<sup>®</sup> family of products is a complete modem ranging in speed from 56,000 bps to 2400 bps. Offered as a chipset with the Si2457, Si2434, Si2415, or Si2404 system-side device and the Si3018/10 line-side device, the ISOModem utilizes Silicon Laboratories' patented direct access arrangement (DAA) technology to provide a programmable telephone line interface with an unparalleled level of integration. These compact solutions eliminate the need for a separate DSP, modem controller, codec, transformer, relay, opto-isolators, clocking crystal, and 2-4 wire hybrid. Available with a system-side packaging option of either a 16-pin SOIC or a 24-pin TSSOP, these devices are ideal for embedded modem applications due to their flexibility, small footprint, and minimal external component count.

### Functional Block Diagram

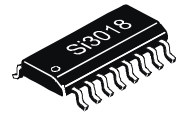
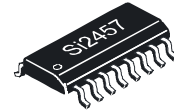
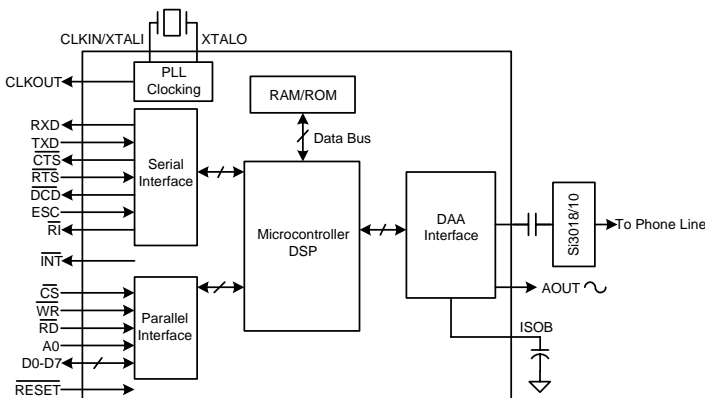

### Ordering Information

This data sheet is valid only for those chipset combinations listed on page 70.

### Pin Assignments

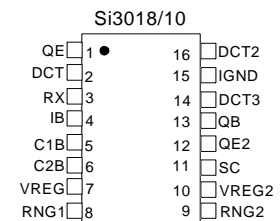
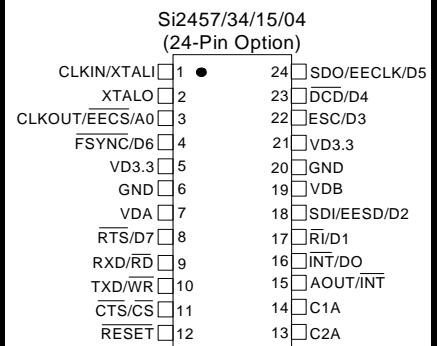
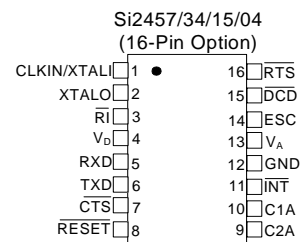



---

**TABLE OF CONTENTS**

---

<b><u>Section</u></b>	<b><u>Page</u></b>
<b>1. Electrical Specifications</b> .....	<b>4</b>
<b>2. Typical Application Schematic</b> .....	<b>10</b>
<b>3. Bill of Materials: Si2457/34/15/04 Chipset</b> .....	<b>12</b>
<b>4. Functional Description</b> .....	<b>16</b>
4.1. Serial Interface .....	16
4.2. Parallel Interface (24-Pin Version Only) .....	16
4.3. Command Mode .....	17
4.4. Data Mode .....	17
4.5. Fast Connect .....	17
4.6. V.80 Synchronous Access Mode .....	17
4.7. Clocking/Low Power Modes .....	17
4.8. Data Compression .....	17
4.9. Error Correction .....	17
4.10. Wire Mode .....	18
4.11. Caller ID Operation .....	18
4.12. Parallel Phone Detection .....	18
4.13. Overcurrent Detection .....	19
4.14. Global Operation .....	19
4.15. Firmware Upgrades .....	19
4.16. SMS / MMS Support .....	19
4.17. Codec Interface (24-Pin Version Only) .....	19
4.18. EEPROM Interface (24-Pin Version Only) .....	20
4.19. AT Commands .....	20
4.20. Extended AT Commands .....	29
<b>5. S-Registers</b> .....	<b>39</b>
<b>6. User-Access Registers (U-Registers)</b> .....	<b>42</b>
6.1. Bit-Mapped U-Register Detail (defaults in bold) .....	48
<b>7. Parallel Interface Registers</b> .....	<b>64</b>
<b>8. Pin Descriptions: Si2457/34/15/04 (16-Pin Option)</b> .....	<b>66</b>
<b>9. Pin Descriptions: Si2457/34/15/04 (24-Pin Option)</b> .....	<b>67</b>
<b>10. Pin Descriptions: Si3018/10</b> .....	<b>69</b>
<b>11. Ordering Guide</b> .....	<b>70</b>
<b>12. Package Outline: 24-Pin TSSOP</b> .....	<b>71</b>
<b>13. Package Outline: 16-Pin SOIC</b> .....	<b>72</b>
<b>Document Change List</b> .....	<b>73</b>
<b>Contact Information</b> .....	<b>74</b>



# Si2457/34/15/04

## 1. Electrical Specifications

**Table 1. Recommended Operating Conditions**

Parameter <sup>1</sup>	Symbol	Test Condition	Min <sup>2</sup>	Typ	Max <sup>2</sup>	Unit
Ambient Temperature	$T_A$	F-grade G-grade	0 -40	25 25	70 85	°C
Si2457/34/15/04 Supply Voltage, Digital <sup>3</sup>	$V_D$		3.0	3.3	3.6	V

**Notes:**

- The Si2457/34/15/04 specifications are guaranteed when the typical application circuit (including component tolerance) and any Si2457/34/15/04 and any Si3018 are used. See "2. Typical Application Schematic" on page 10.
- All minimum and maximum specifications are guaranteed and apply across the recommended operating conditions. Typical values apply at nominal supply voltages and an operating temperature of 25 °C unless otherwise stated.
- The digital supply,  $V_D$ , operates from 3.0 to 3.6 V. The Si2457/34/15/04 interface supports 5 V logic (CLKIN/XTALI supports 3.3 V logic only).

**Table 2. Loop Characteristics**

( $V_D = 3.0$  to  $3.6$  V,  $T_A = 0$  to  $70$  °C for F-grade,  $T_A = -40$  to  $+85$  °C for G-grade)

Parameter	Symbol	Test Condition	Min	Typ	Max	Unit
DC Termination Voltage	$V_{TR}$	$I_L = 20$ mA, $ILIM^1 = 0$ DCV = 00, MINI = 11, DCR = 0	—	—	6.0	V
DC Termination Voltage	$V_{TR}$	$I_L = 120$ mA, $ILIM = 0$ DCV = 00, MINI = 11, DCR = 0	9	—	—	V
DC Termination Voltage	$V_{TR}$	$I_L = 20$ mA, $ILIM = 0$ DCV = 11, MINI = 00, DCR = 0	—	—	7.5	V
DC Termination Voltage	$V_{TR}$	$I_L = 120$ mA, $ILIM = 0$ DCV = 11, MINI = 00, DCR = 0	9	—	—	V
DC Termination Voltage	$V_{TR}$	$I_L = 20$ mA, $ILIM = 1$ DCV = 11, MINI = 00, DCR = 0	—	—	7.5	V
DC Termination Voltage	$V_{TR}$	$I_L = 60$ mA, $ILIM = 1$ DCV = 11, MINI = 00, DCR = 0	40	—	—	V
DC Termination Voltage	$V_{TR}$	$I_L = 50$ mA, $ILIM = 1$ DCV = 11, MINI = 00, DCR = 0	—	—	40	V
On-Hook Leakage Current	$I_{LK}$	$V_{TR} = -48$ V	—	—	5	µA
Operating Loop Current	$I_{LP}$	MINI = 00, $ILIM = 0$	10	—	120	mA
Operating Loop Current	$I_{LP}$	MINI = 00, $ILIM = 1$	10	—	60	mA
DC Ring Current		DC current flowing through ring detection circuitry	—	1.5	3	µA
Ring Detect Voltage <sup>2</sup>	$V_{RD}$	RT = 0	12	15	18	$V_{RMS}$
Ring Detect Voltage <sup>2</sup>	$V_{RD}$	RT = 1	18	21	25	$V_{RMS}$
Ring Frequency	$F_R$		15	—	68	Hz
Ringer Equivalence Number	REN		—	—	0.2	

**Notes:**

- $ILIM = U67$ , bit 9; DCV = U67, bits 3:2; MINI = U67, bits 13:12; DCR = U67, bit 7; RT = U67, bit 0.
- The ring signal is guaranteed to not be detected below the minimum. The ring signal is guaranteed to be detected above the maximum.

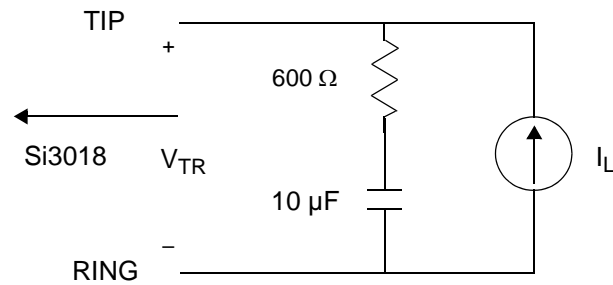

Figure 1. Test Circuit for Loop Characteristics

Table 3. DC Characteristics,  $V_D = 3.0$  to  $3.6$  V

( $V_D = 3.0$  to  $3.6$  V,  $T_A = 0$  to  $70$  °C for F-grade,  $T_A = -40$  to  $+85$  °C for G-grade)

Parameter	Symbol	Test Condition	Min	Typ	Max	Unit
High Level Input Voltage	$V_{IH}$		2.0	—	—	V
Low Level Input Voltage	$V_{IL}$		—	—	0.8	V
High Level Output Voltage	$V_{OH}$	$I_O = -2$ mA	2.4	—	—	V
Low Level Output Voltage	$V_{OL}$	$I_O = 2$ mA	—	—	0.35	V
Input Leakage Current	$I_L$		-10	—	10	$\mu$ A
Pullup Resistance Pins 3, 4, 9, 11, 15, 16, 17, 18, 23, 24 (24-pin option)	$R_{PU}$		50	125	200	k $\Omega$
Pullup Resistance Pins 3, 5, 7, 9, 11, 15, 16 (16-pin option)	$R_{PU}$		50	125	200	k $\Omega$
Total Supply Current*	$I_D$	$V_{D3.3}$ pin	—	26	35	mA
Total Supply Current, Powerdown*	$I_D$	PDN = 1	—	80	—	$\mu$ A

\*Note: All inputs at 0 or  $V_D$ . All inputs held static except clock and all outputs unloaded (Static  $I_{OUT} = 0$  mA).

**Table 4. AC Characteristics**

( $V_D = 3.0$  to  $3.6$  V,  $T_A = 0$  to  $70$  °C for F-grade,  $T_A = -40$  to  $+85$  °C for G-grade,  $F_s = 8$  kHz)

Parameter	Symbol	Test Condition	Min	Typ	Max	Unit
Sample Rate	$F_s$		—	8	—	kHz
Clock Input Frequency	$F_{XTL}$	default	—	4.9152	—	MHz
Clock Input Frequency	$F_{XTL}$	$\geq 10$ k $\Omega$ resistor between DCD and GND	—	27	—	MHz
Receive Frequency Response		Low -3 dBFS Corner, FILT = 0	—	5	—	Hz
Receive Frequency Response		Low -3 dBFS Corner, FILT = 1	—	200	—	Hz
Transmit Full Scale Level <sup>1</sup>	$V_{FS}$		—	1.1	—	$V_{PEAK}$
Receive Full Scale Level <sup>1,2</sup>	$V_{FS}$		—	1.1	—	$V_{PEAK}$
Dynamic Range <sup>3</sup>	DR	ILIM = 0, DCV = 11, MINI = 00 DCR = 0, $I_L = 100$ mA	—	80	—	dB
Dynamic Range <sup>3</sup>	DR	ILIM = 0, DCV = 00, MINI = 11 DCR = 0, $I_L = 20$ mA	—	80	—	dB
Dynamic Range <sup>3</sup>	DR	ILIM = 1, DCV = 11, MINI = 00 DCR = 0, $I_L = 50$ mA	—	80	—	dB
Transmit Total Harmonic Distortion <sup>4</sup>	THD	ILIM = 0, DCV = 11, MINI = 00 DCR = 0, $I_L = 100$ mA	—	-72	—	dB
Transmit Total Harmonic Distortion <sup>4</sup>	THD	ILIM = 0, DCV = 00, MINI = 11 DCR = 0, $I_L = 20$ mA	—	-78	—	dB
Receive Total Harmonic Distortion <sup>4</sup>	THD	ILIM = 0, DCV = 00, MINI = 11 DCR = 0, $I_L = 20$ mA	—	-78	—	dB
Receive Total Harmonic Distortion <sup>4</sup>	THD	ILIM = 1, DCV = 11, MINI = 00 DCR = 0, $I_L = 50$ mA	—	-78	—	dB
Dynamic Range (Caller ID Mode)	$DR_{CID}$	$V_{IN} = 1$ kHz, -13 dBm	—	50	—	dB

**Notes:**

1. Measured at TIP and RING with 600  $\Omega$  termination at 1 kHz, as shown in Figure 1 on page 5.
2. Receive full scale level produces -0.9 dBFS at DTX.
3.  $DR = 20 \times \log |V_{in}| + 20 \times \log (\text{rms signal/rms noise})$ . Applies to both transmit and receive paths.  $V_{in} = 1$  kHz, -3 dBFS.
4.  $V_{in} = 1$  kHz, -3 dBFS.  $THD = 20 \times \log (\text{rms distortion/rms signal})$ .

Table 5. Absolute Maximum Ratings

Parameter	Symbol	Value	Unit
DC Supply Voltage	$V_D$	4.1	V
Input Current, Si2457/34/15/04 Digital Input Pins	$I_{IN}$	$\pm 10$	mA
Digital Input Voltage	$V_{IND}$	-0.3 to 5.3	V
CLKIN/XTALI Input Voltage	$V_{XIND}$	-0.3 to ( $V_D + 0.3$ )	V
Operating Temperature Range	$T_A$	-10 to 100	°C
Storage Temperature Range	$T_{STG}$	-40 to 150	°C

**Note:** Permanent device damage may occur if the above absolute maximum ratings are exceeded. Functional operation should be restricted to the conditions as specified in the operational sections of this data sheet. Exposure to absolute maximum rating conditions for extended periods may affect device reliability.

Table 6. Switching Characteristics

( $V_D = 3.0$  to  $3.6$  V,  $T_A = 0$  to  $70$  °C for F-grade,  $T_A = -40$  to  $+85$  °C for G-grade)

Parameter	Symbol	Min	Typ	Max	Unit
CLKOUT Output Clock Frequency		2.048	—	49.152	MHz
Baud Rate Accuracy	$t_{BD}$	-1	—	1	%
Start Bit $\downarrow$ to $\overline{RTS}$ $\downarrow$	$t_{RTH}$	—	$1/(2 \times \text{Baud Rate})$	—	ns
$\overline{CTS}$ or $\overline{RTS}$ $\uparrow$ High to Start Bit $\downarrow$	$t_{RTS}$	10	—	—	ns
Stop Bit $\uparrow$ to $\overline{CTS}$ $\uparrow$	$t_{CTH}$	—	—	—	ns
$\overline{RESET}$ $\downarrow$ to $\overline{RESET}$ $\uparrow$	$t_{RS}$	5.0	—	—	ms
$\overline{RESET}$ $\uparrow$ to 1st AT Command	$t_{AT}$	300	—	—	ms
Address Setup	$t_{AS}$	15	—	—	ns
Address Hold	$t_{AH}$	0	—	—	ns
$\overline{WR}$ Low Pulse Width	$t_{WL}$	50	—	—	ns
Write Data Setup Time	$t_{WDSU}$	20	—	—	ns
Write Cycle Time	$t_{WC}$	120	—	—	ns
Chip Select Setup	$t_{CSS}$	10	—	—	ns
Chip Select Hold	$t_{CSH}$	0	—	—	ns
$\overline{RD}$ Low Pulse Width	$t_{RL}$	50	—	—	ns
$\overline{RD}$ Low to Data Driven Time	$t_{RLDD}$	—	—	20	ns
Data Hold	$t_{DH}$	10	—	—	ns
$\overline{RD}$ High to Hi-Z Time	$t_{DZ}$	—	—	30	ns
Read Cycle Time	$t_{RC}$	120	—	—	ns

**Note:** All timing is referenced to the 50% level of the waveform. Input test levels are  $V_{IH} = V_D - 0.4$  V,  $V_{IL} = 0.4$  V



## UART Time for Modem Receive Path (8N1 Mode)

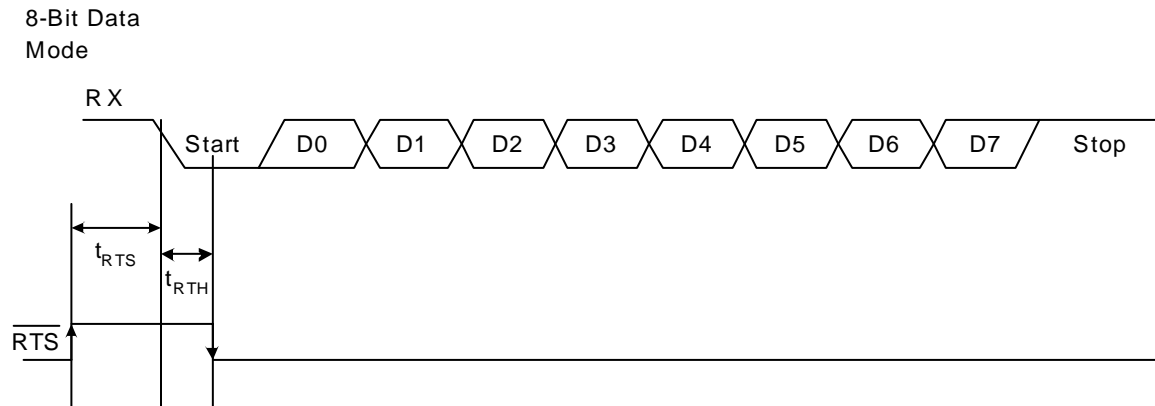

## UART Timing for Modem Transmit Path (9N1 Mode with 9th Bit Escape)

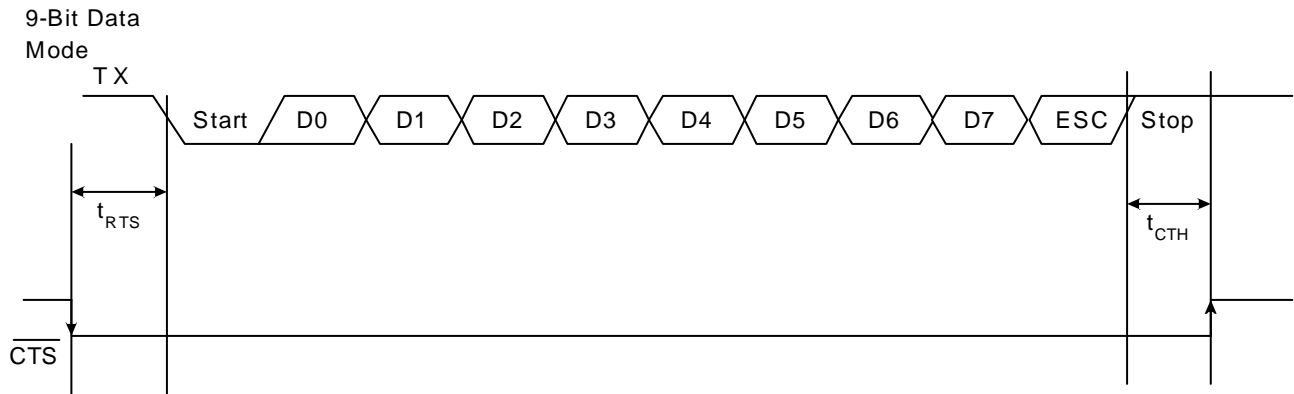

**Figure 2. Asynchronous UART Serial Interface Timing Diagram**



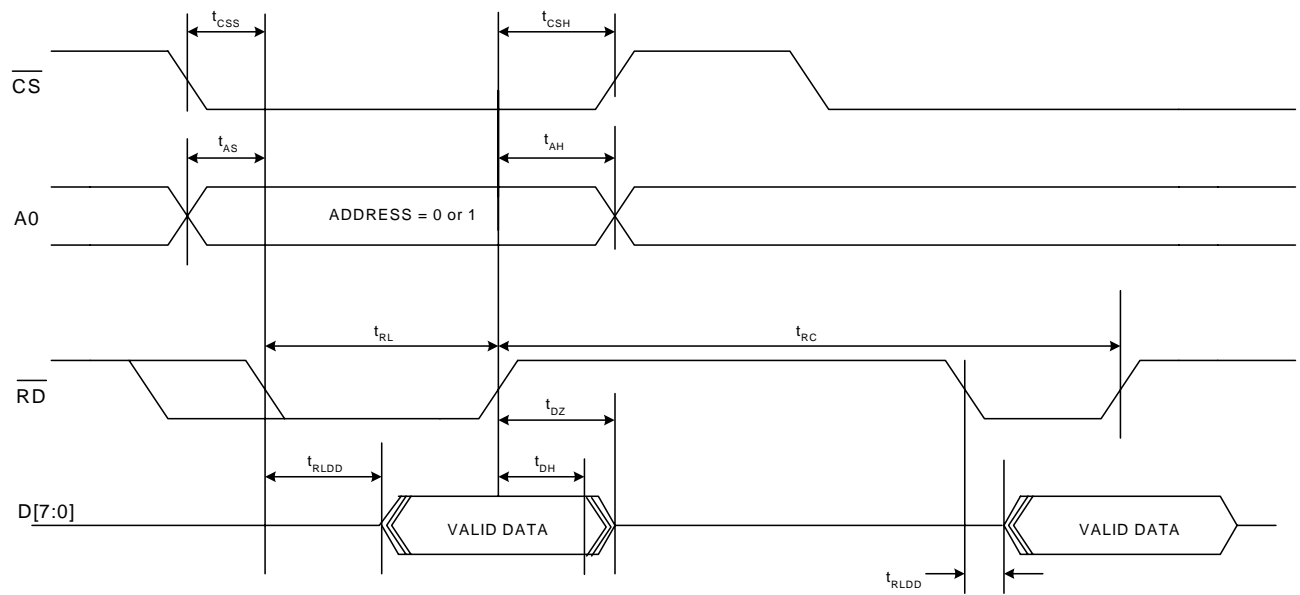

Figure 3. Parallel Interface Read Timing

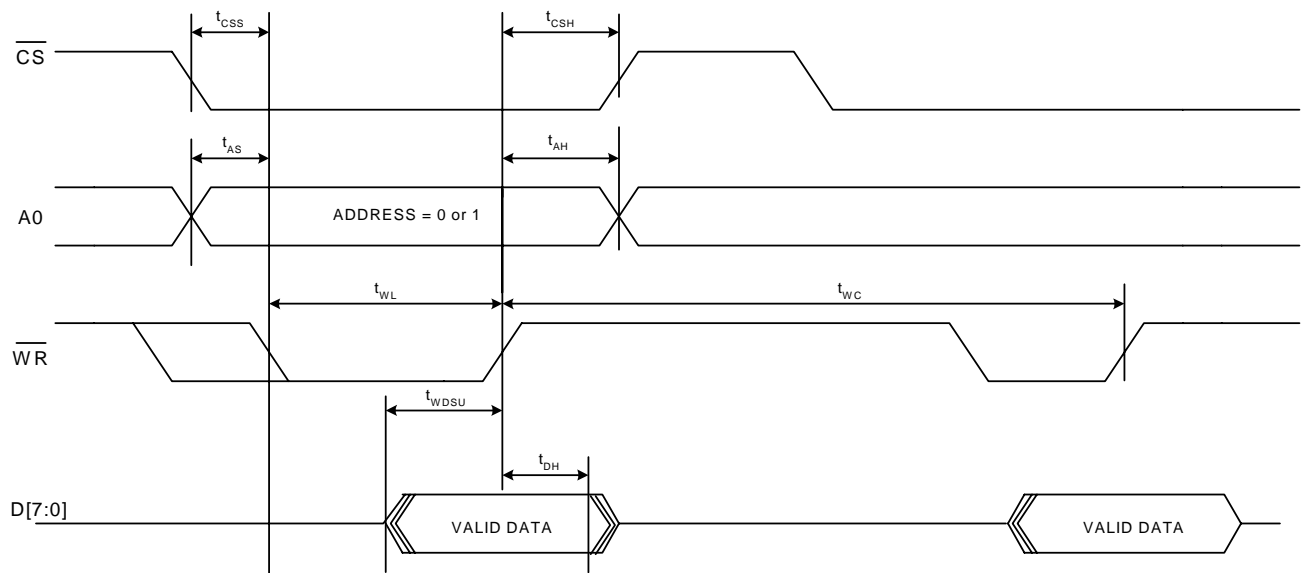

Figure 4. Parallel Interface Write Timing

## 2. Typical Application Schematic

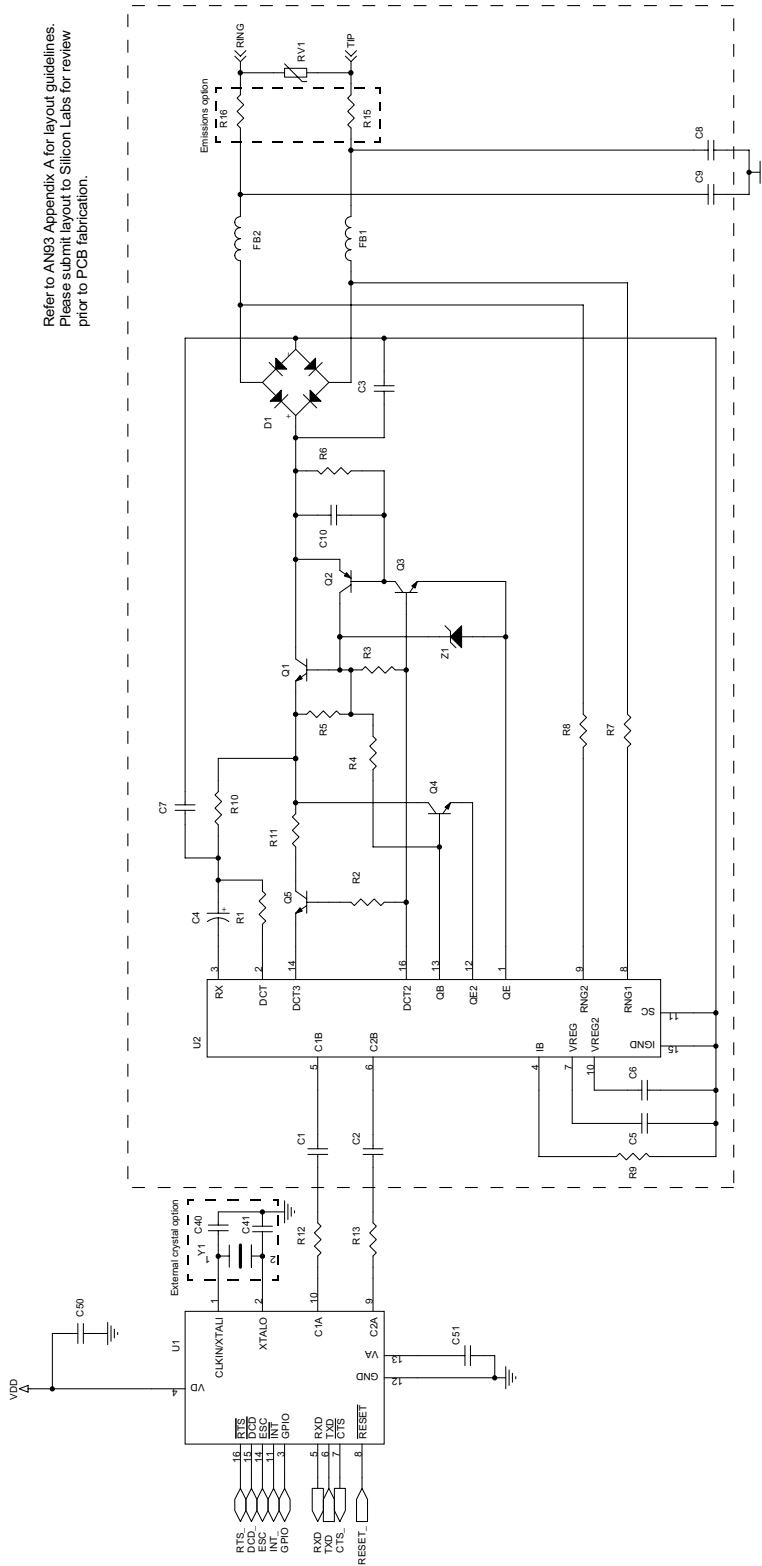

Figure 5. Typical Schematic with 16-pin System-Side Option

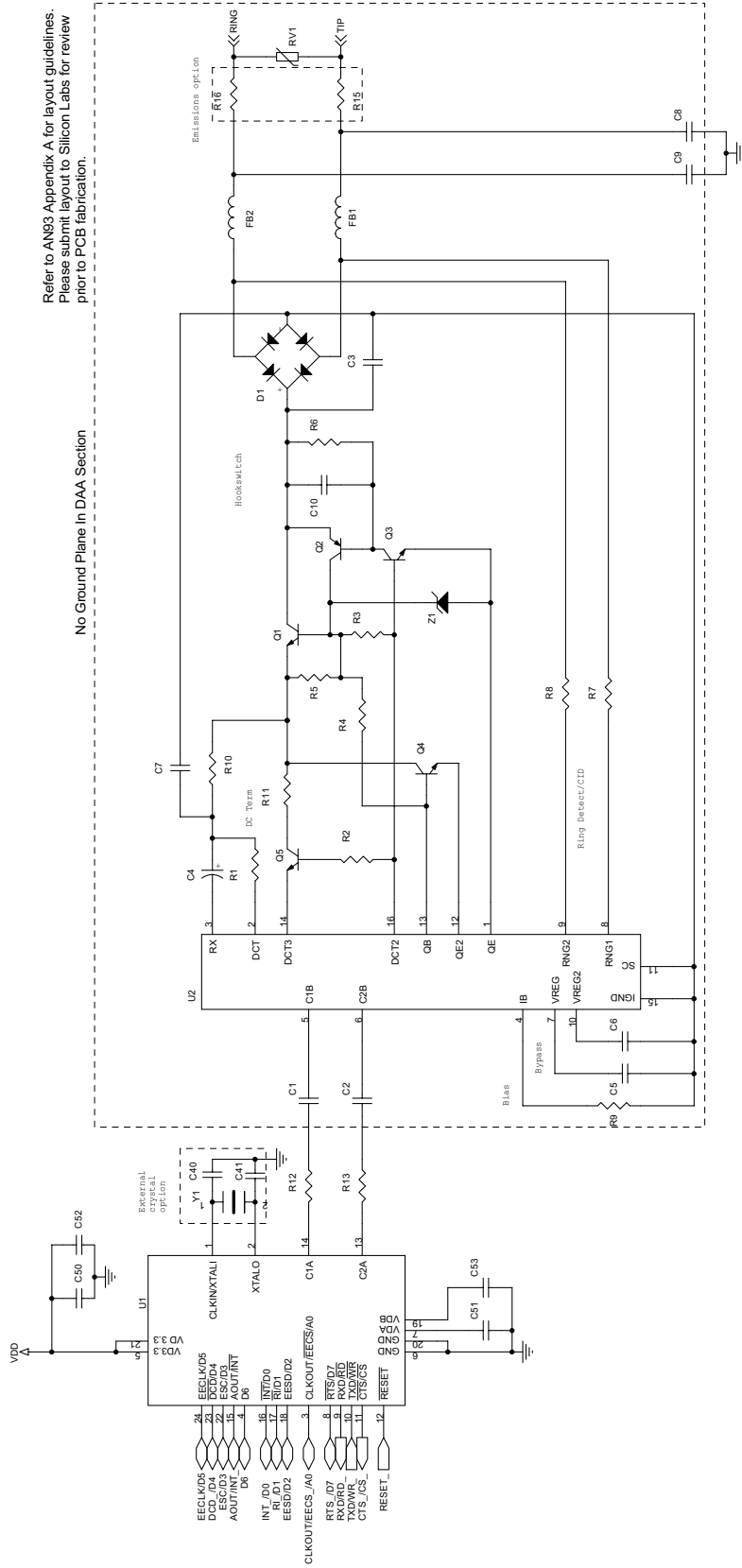

Figure 6. Typical Schematic with 24-pin System-Side Option



## 3. Bill of Materials: Si2457/34/15/04 Chipset

Component	Value	Supplier(s)
C1, C2	33 pF, Y2, X7R, ±20%	Panasonic, Murata, Vishay
C3	10 nF, 250 V, X7R, ±20%	Venkel, SMEC
C4	1.0 μF, 50 V, Elec/Tant, ±20%	Panasonic
C5, C6, C50, C52 <sup>1</sup>	0.1 μF, 16 V, X7R, ±20%	Venkel, SMEC
C7	2.7 nF, 50 V, X7R, ±20%	Venkel, SMEC
C8, C9	680 pF, Y2, X7R, ±10%	Panasonic, Murata, Vishay
C10	0.01 μF, 16 V, X7R, ±20%	Venkel, SMEC
C40, C41 <sup>2</sup>	33 pF, 16 V, NPO, ±5%	Venkel, SMEC
C51, C53 <sup>1</sup>	0.22 μF, 16 V, X7R, ±20%	Venkel, SMEC
D1, D2 <sup>3</sup>	Dual Diode, 225 mA, 300 V, CMPD2004S	Central Semiconductor
FB1, FB2	Ferrite Bead, BLM21AG601SN1	Murata
Q1, Q3	NPN, 300 V, MMBTA42	OnSemi, Fairchild
Q2	PNP, 300 V, MMBTA92	OnSemi, Fairchild
Q4, Q5	NPN, 80 V, 330 mW, MMBTA06	OnSemi, Fairchild
RV1	Sidactor, 275 V, 100 A	Teccor, Protek, ST Micro
R1	1.07 kΩ, 1/2 W, 1%	Venkel, SMEC, Panasonic
R2	150 Ω, 1/16 W, 5%	Venkel, SMEC, Panasonic
R3	3.65 kΩ, 1/2 W, 1%	Venkel, SMEC, Panasonic
R4	2.49 kΩ, 1/2 W, 1%	Venkel, SMEC, Panasonic
R5, R6	100 kΩ, 1/16 W, 5%	Venkel, SMEC, Panasonic
R7, R8	20 MΩ, 1/16 W, 5%	Venkel, SMEC, Panasonic
R9	1 MΩ, 1/16 W, 1%	Venkel, SMEC, Panasonic
R10	536 Ω, 1/4 W, 1%	Venkel, SMEC, Panasonic
R11	73.2 Ω, 1/2 W, 1%	Venkel, SMEC, Panasonic
R12, R13	56 Ω, 1/16 W, 1%	Venkel, SMEC, Panasonic
R15, R16 <sup>4</sup>	0 Ω, 1/16 W	Venkel, SMEC, Panasonic
U1	Si2457/34/15/04	Silicon Labs
U2	Si3018/10	Silicon Labs
Y1 <sup>2,5</sup>	4.9152 MHz, 20 pF, 100 ppm, 150 Ω ESR	ECS Inc., Siward
Z1	Zener Diode, 43 V, 1/2 W, BZT84C43	On Semi

**Notes:**

1. C52 and C53 should not be populated with the Si2457/34/15/04 16-pin package option.
2. In STB applications, C40, C41, and Y1 can be removed by using the 27 MHz clock input feature.
3. Several diode bridge configurations are acceptable. For example, a single DF04S or four 1N4004 diodes may be used.
4. Murata BLM21AG601SN1 may be substituted for R15–R16 (0 Ω) to decrease emissions.
5. To ensure compliance with ITU specifications, frequency tolerance must be less than 100 ppm including initial accuracy, 5-year aging, 0 to 70 °C, and capacitive loading. 50 ppm initial accuracy crystals typically satisfy this requirement.

Table 7. Protocol Characteristics

Item	Specification
<b>Data Rate</b>	
56 kbps <sup>1</sup>	ITU-T V.90 <sup>1</sup>
54.666 kbps <sup>1</sup>	ITU-T V.90 <sup>1</sup>
53.333 kbps <sup>1</sup>	ITU-T V.90 <sup>1</sup>
52 kbps <sup>1</sup>	ITU-T V.90 <sup>1</sup>
50.666 kbps <sup>1</sup>	ITU-T V.90 <sup>1</sup>
49.333 kbps <sup>1</sup>	ITU-T V.90 <sup>1</sup>
48 kbps <sup>1</sup>	ITU-T V.90 <sup>1</sup>
46.666 kbps <sup>1</sup>	ITU-T V.90 <sup>1</sup>
45.333 kbps <sup>1</sup>	ITU-T V.90 <sup>1</sup>
44 kbps <sup>1</sup>	ITU-T V.90 <sup>1</sup>
42.666 kbps <sup>1</sup>	ITU-T V.90 <sup>1</sup>
41.333 kbps <sup>1</sup>	ITU-T V.90 <sup>1</sup>
40 kbps <sup>1</sup>	ITU-T V.90 <sup>1</sup>
38.666 kbps <sup>1</sup>	ITU-T V.90 <sup>1</sup>
37.333 kbps <sup>1</sup>	ITU-T V.90 <sup>1</sup>
36 kbps <sup>1</sup>	ITU-T V.90 <sup>1</sup>
34.666 kbps <sup>1</sup>	ITU-T V.90 <sup>1</sup>
33.333 kbps <sup>1</sup>	ITU-T V.90 <sup>1</sup>
32 kbps <sup>1</sup>	ITU-T V.90 <sup>1</sup>
30.666 kbps <sup>1</sup>	ITU-T V.90 <sup>1</sup>
29.333 kbps <sup>1</sup>	ITU-T V.90 <sup>1</sup>
28 kbps <sup>1</sup>	ITU-T V.90 <sup>1</sup>
33.6 kbps <sup>2</sup>	ITU-T V.34 <sup>2</sup>
31.2 kbps <sup>2</sup>	ITU-T V.34 <sup>2</sup>
28.8 kbps <sup>2</sup>	ITU-T V.34 <sup>2</sup>
26.4 kbps <sup>2</sup>	ITU-T V.34 <sup>2</sup>
24.0 kbps <sup>2</sup>	ITU-T V.34 <sup>2</sup>
21.6 kbps <sup>2</sup>	ITU-T V.34 <sup>2</sup>
19.2 kbps <sup>2</sup>	ITU-T V.34 <sup>2</sup>
16.8 kbps <sup>2</sup>	ITU-T V.34 <sup>2</sup>
14.4 kbps <sup>3</sup>	ITU-T V.34 or V.32bis <sup>3</sup>
12.0 kbps <sup>3</sup>	ITU-T V.34 or V.32bis <sup>3</sup>
9600 bps <sup>3</sup>	ITU-T V.34, V.32bis, or V.29 <sup>3</sup>
7200 bps <sup>3</sup>	ITU-T V.34 or V.32bis <sup>3</sup>
4800 bps <sup>3</sup>	ITU-T V.34 or V.32bis <sup>3</sup>
2400 bps	ITU-T V.34 or V.22bis <sup>3</sup>
1200 bps	ITU-T V.22bis, V.23, or Bell 212A
300 bps	ITU-T V.21
300 bps	Bell 103
<b>Data Format</b>	
Bit asynchronous	Selectable 8, 9, 10, or 11 bits per character
<b>Notes:</b>	
1. Supported on Si2457 only.	
2. Supported on Si2457 and Si2434 only.	
3. Supported on Si2457, Si2434, and Si2415 only.	



Table 7. Protocol Characteristics (Continued)

Item	Specification
Compatibility	ITU-T V.90 <sup>1</sup> , V.34 <sup>2</sup> , V.32bis, V.32, V.23, V.22bis, V.22, V.21, Bell 212A, and Bell 103
<b>Operating Mode</b> Switched network	Two-wire full duplex
<b>Data Modulation</b> 28 to 56 kbps <sup>1</sup> 2.4 to 33.6 kbps <sup>2</sup> 14.4 kbps <sup>3</sup> 12.0 kbps <sup>3</sup> 9600 bps <sup>3</sup> 9600 bps <sup>3</sup> 9600 bps <sup>3</sup> 7200 bps <sup>3</sup> 4800 bps <sup>3</sup> 2400 bps 1200 bps 0 to 300 bps	V.90 as specified by ITU-T V.34 as specified by ITU-T 128-level TCM/2400 Baud $\pm 0.01\%$ 64-level TCM/2400 Baud $\pm 0.01\%$ 32-level TCM/2400 Baud $\pm 0.01\%$ 16-level QAM/2400 Baud $\pm 0.01\%$ V.29 QAM as specified by ITU-T 16-level TCM/2400 Baud $\pm 0.01\%$ 4-level QAM/2400 Baud $\pm 0.01\%$ 16-level QAM/600 Baud $\pm 0.01\%$ 4-level PSK/600 Baud $\pm 0.01\%$ FSK 0–300 Baud $\pm 0.01\%$
<b>Answer Tone</b> ITU-T V.32bis, V.32, V.22bis, V.22, and V.21 modes Bell 212A and 103 modes	2100 Hz $\pm 3$ Hz  2225 Hz $\pm 3$ Hz
<b>Transmit Carrier</b> V.90 <sup>1</sup> V.34 <sup>2</sup> ITU-T V.32bis <sup>3</sup> ITU-T V.32 <sup>3</sup> ITU-T V.29 <sup>3</sup> ITU-T V.22, V.22bis/Bell 212A Originate mode Answer mode ITU-T V.21 Originate mode Answer mode Bell 103 Originate mode Answer mode	As specified by ITU-T As specified by ITU-T 1800 Hz $\pm 0.01\%$ 1800 Hz $\pm 0.01\%$ 1700 Hz $\pm 1$ Hz 1200 Hz $\pm 0.5$ Hz 2400 Hz $\pm 1$ Hz  Mark (980 Hz $\pm 12$ Hz) Space (1180 Hz $\pm 12$ Hz) Mark (1650 Hz $\pm 12$ Hz) Space (1850 Hz $\pm 12$ Hz)  Mark (1270 Hz $\pm 12$ Hz) Space (1070 Hz $\pm 12$ Hz) Mark (2225 Hz $\pm 12$ Hz) Space (2025 Hz $\pm 12$ Hz)
<b>Output Level</b> Permissive—Switched network	–9 dBm maximum
<b>Notes:</b> 1. Supported on Si2457 only. 2. Supported on Si2457 and Si2434 only. 3. Supported on Si2457, Si2434, and Si2415 only.	

Table 7. Protocol Characteristics (Continued)

Item	Specification
<b>Receive Carrier</b>	
ITU-T V.90 <sup>1</sup>	As specified by ITU-T
ITU-T V.34 <sup>2</sup>	As specified by ITU-T
ITU-T V.32bis <sup>3</sup>	1800 Hz $\pm$ 7 Hz
ITU-T V.32 <sup>3</sup>	1800 Hz $\pm$ 7 Hz
ITU-T V.29 <sup>3</sup>	1700 Hz $\pm$ 7 Hz
ITU-T V.22, V.22bis/Bell 212A	2400 Hz $\pm$ 7 Hz
Originate mode	1200 Hz $\pm$ 7 Hz
Answer mode	
ITU-T V.21	Mark (980 Hz $\pm$ 12 Hz) Space (1180 Hz $\pm$ 12 Hz)
Originate mode	Mark (1650 Hz $\pm$ 12 Hz) Space (1850 Hz $\pm$ 12 Hz)
Answer mode	
Bell 103	Mark (2225 Hz $\pm$ 12 Hz) Space (2025 Hz $\pm$ 12 Hz)
Originate mode	Mark (1270 Hz $\pm$ 12 Hz) Space (1070 Hz $\pm$ 12 Hz)
Answer mode	
Carrier Detect (level for ITU-T V.22bis, V.22, V.21, 212, 103) in Switched Network	Acquisition (–43 dBm) Release (–48 dBm)
Hysteresis	2 dBm minimum
<b>Note:</b> ITU-T V.90 <sup>1</sup> , V.34 <sup>2</sup> , V.32/V.32bis <sup>3</sup> are echo canceling protocols that use signal quality as criteria for maintaining connection. They also provide for self-training detection to force disconnect.	
DTE Interface	EIA/TIA-232-E (ITU-T V.24/V.28/ISO 2110)
Line Equalization	Automatic Adaptive
Connection Options	Loss of Carrier in ITU-T V.22bis and lower
Phone Types	500 (rotary dial), 2500 (DTMF dial)
Dialing	Pulse and Tone
DTMF Output Level	Per Part 68
Pulse Dial Ratio	Make/Break: 39/61%
Ring Cadence	On 2 seconds; Off 4 seconds
Call Progress Monitor	BUSY CONNECT (rate) NO ANSWER NO CARRIER NO DIALTONE OK RING RINGING
<b>Notes:</b>	
1. Supported on Si2457 only.	
2. Supported on Si2457 and Si2434 only.	
3. Supported on Si2457, Si2434, and Si2415 only.	



## 4. Functional Description

The Si2457/34/15/04 ISModem<sup>®</sup> is a complete embedded modem chipset with integrated direct access arrangement (DAA) that provides a programmable line interface to meet global telephone line requirements. Available in two small packages, this solution includes a DSP data pump, modem controller, on-chip RAM and ROM, codec, DAA, analog output, and 27 MHz clock input.

The Si2457/34/15/04 accepts standard modem AT commands and provides connect rates up to 56/33.6/14.4/2.4 kbps full-duplex over the Public Switched Telephone Network (PSTN). The Si2457/34/15/04 features a complete set of modem protocols including all ITU-T standard formats up to 56 kbps.

To provide the most flexibility, the Si2457/34/15/04 ISModem system-side device is offered in either a 24-pin TSSOP or a 16-pin SOIC package. The 16-pin version is footprint-compatible with the Si2401 ISModem and is recommended for most applications. The 16-pin version does not support the parallel, EEPROM or voice codec interface. If these features are required, customers should use the 24-pin version.

The ISModem provides numerous additional features for embedded modem applications. The modem includes full type I and type II caller ID detection and decoding for global standards. Call progress monitoring is supported through standard result codes. The modem is also programmable to meet global settings. Because the Si2457/34/15/04 ISModem integrates the DAA, analog features, such as parallel phone detect, overcurrent detection, and global PTT compliance with a single design, are included.

This device is ideal for embedded modem applications due to its small board space, low power consumption, and global compliance. The Si2457/34/15/04 solution includes a silicon DAA using Silicon Laboratories' proprietary third-generation DAA technology. This highly-integrated DAA can be programmed to meet worldwide PTT specifications for ac termination, dc termination, ringer impedence, and ringer threshold. In addition, the Si2457/34/15/04 has been designed to meet the most stringent worldwide requirements for out-of-band energy, billing-tone immunity, surge immunity, and safety requirements.

The Si2457/34/15/04 allows for rapid integration into existing modem applications by providing a serial interface that can directly communicate to either a microcontroller via a UART interface or a PC via an RS-232 port. This interface allows for PC evaluation of the modem immediately upon powerup via the AT commands using standard terminal software.

### 4.1. Serial Interface

The Si2457/34/15/04 supports asynchronous serial communication with data terminal equipment (DTE) at rates up to 307.2 kbps with the standard serial UART format. Upon powerup, the UART baud rate is automatically detected using the autobaud feature.

The serial interface also provides a hardware pin,  $\overline{\text{DCD}}$  (data carrier detect), which remains low as long as the ISModem is connected.

The  $\overline{\text{INT}}$  interrupt pin can be programmed to alert the host of changes to the interrupts listed in I/O Control 0 (U70).

To ensure backward compatibility when using a 24-pin system side option, if a pulldown resistor  $\leq 10 \text{ k}\Omega$  is placed between D2 (Si2457/34/15/04, pin 18) and GND (Si2457/34/15/04, pin 6), the DTE rate is set to a 19.2 kbps baud rate (see Table 8).

#### 4.1.1. Autobaud

The Si2457/34/15/04 includes an automatic baud rate detection feature that allows the host to start transmitting data at any standard DTE rate from 300 bps to 307.2 kbps. This feature is enabled by default.

### 4.2. Parallel Interface (24-Pin Version Only)

The Si2457/34/15/04 digital I/O can communicate via a parallel interface. The parallel interface is an 8-bit data bus with a single bit address. Figure 3 on page 9 shows the required timing for the parallel interface.

If  $A0 = 0$ , the data bus represents a read/write to the "Parallel Interface 0 (0x00)" register on page 64. If  $A0 = 1$ , the data bus represents a read/write to the "Parallel Interface 1 (0x01)" register on page 65.

Selection of a serial or parallel I/O interface is determined by the state of  $\text{AOUT}/\overline{\text{INT}}$  (Si2457/34/15/04, pin 15) during the rising edge of  $\overline{\text{RESET}}$ . An internal pullup resistor forces the default state to serial mode operation. An external  $10 \text{ k}\Omega$  pulldown resistor can be connected to  $\text{AOUT}/\overline{\text{INT}}$  to force selection of parallel mode (see Table 8). Configuration of pins 3, 4, 8–11, 15–18, and 22–24 is determined by this interface selection.



Table 8. Pulldown Selector (24-Pin SSD)

Mode	Serial I/O	Parallel I/O
4.9152 MHz CLK	Default	Pin 15
27 MHz CLK	Pin 23	Pin 11, 15
Autobaud	Default	N/A
19.2 kbps DTE	Pin 18	
No EEPROM	Default	N/A
EEPROM	Pin 4	

Table 9. Pulldown Selector (16-Pin Version)

Mode	Serial I/O
4.9152 MHz CLK	Default
27 MHz CLK	Pin 15

### 4.3. Command Mode

Upon reset, the ISModem<sup>®</sup> is in command mode and accepts “AT” commands. An outgoing modem call can be made using the “ATDT#” (tone dial) or “ATDP#” (pulse dial) command after the device is configured. If the handshake is successful, the modem responds with the response codes detailed in Table 14 on page 36 and enters data mode.

### 4.4. Data Mode

The Si2457/34/15/04 ISModem is in data mode while it has a telephone line connection to another modem or is in the process of establishing a connection.

Data protocols are available to provide error correction to improve reliability (V.42 and MNP2-4) and data compression to increase throughput (V.42bis and MNP5).

Each connection between two modems in data mode begins with a handshaking sequence. During this sequence, the modems determine the line speed, data protocol, and related parameters for the data link. Configuration through AT commands determines the range of choices available to the modem during the negotiation process.

### 4.5. Fast Connect

The Si2457/34/15/04 supports a fast connect mode of operation to reduce the time of a connect sequence in originate mode. The Fast Connect modes can be enabled for V.21, V.22, Bell103, and V.29 modulations. See “AN93: Modem Designer’s Guide” for details.

### 4.6. V.80 Synchronous Access Mode

The Si2457/34/15/04 supports a V.80 synchronous

access mode of operation, which operates with an asynchronous DTE and a synchronous DCE. See “AN93: Modem Designer’s Guide” for complete details.

### 4.7. Clocking/Low Power Modes

The Si2457/34/15/04 contains an on-chip phase-locked loop (PLL) and clock generator. Using either a single crystal or master clock input, the Si2457/34/15/04 can generate all the internal clocks required to support the featured modem protocols. Either a 27 MHz or 4.9152 MHz clock (3.3 V max input—see Table 5 on page 7) on XTALI or a 4.9152 MHz crystal across XTALI and XTALO form the master clock ( $\pm 100$  ppm max) for the ISModem. This clock source is sent to an internal PLL that generates all necessary internal system clocks including the DSP clock. By default, the Si2457/34/15/04 assumes a 4.9152 MHz clock input. If a 27 MHz clock on XTALI is used with the serial (UART) interface, a pulldown resistor  $\leq 10$  k $\Omega$  must be placed between DCD and GND. If a 27 MHz clock on XTALI is used with the parallel interface, a pulldown resistor  $\leq 10$  k $\Omega$  must be placed between  $\overline{\text{CTS/CS}}$  (pin 11) and GND and  $\overline{\text{AOUT/INT}}$  and GND (see Tables 8 and 9).

Using the S24 S-register, the Si2457/34/15/04 can be set to automatically enter sleep mode after a pre-programmed time of inactivity with either the DTE or the remote modem. The sleep mode is entered after (S24) seconds have passed since the TX FIFO has been empty. The ISModem remains in the sleep state until either a 1 to 0 transition on TXD (serial mode) or a 1 to 0 transition on  $\overline{\text{CS}}$  (parallel mode) occurs.

Additionally, the Si2457/34/15/04 may be placed in a complete powerdown mode or wake-on-ring mode. Complete powerdown is accomplished via U65[13] (PDN). Once the PDN bit is written, the Si2457/34/15/04 completely powers down and can only be powered back on via the  $\overline{\text{RESET}}$  pin.

### 4.8. Data Compression

The modem can achieve DTE (host-to-ISModem) speeds greater than the maximum DCE (modem-to-modem) speed through the use of a data compression protocol. The compression protocols available are the ITU-T V.42bis and MNP5 protocols. Data compression attempts to increase throughput by compressing the data before actually sending it. Thus, the modem is able to transmit more data in a given period of time.

### 4.9. Error Correction

The Si2457/34/15/04 ISModem can employ error correction (reliable) protocols to ensure error-free delivery of asynchronous data sent between the host and the remote end. The Si2457/34/15/04 supports V.42



and MNP2-4 error correction protocols. V.42 (LAPM) is most commonly used and is enabled by default.

## 4.10. Wire Mode

Wire mode is used to communicate with standard non-error correcting modems. When optioned with \N3, the Si2457/34/15/04 falls back to wire mode if it fails in an attempt to negotiate a V.42 link with the remote modem. Error correction and data compression are not active in wire mode.

## 4.11. Caller ID Operation

The Si2457/34/15/04 supports full type I and type II caller ID detection and decode. Caller ID is supported for the US Bellcore, European ETSI, UK, and Japanese protocols and is enabled via the +VCID, +VCDT, and +PCW commands.

## 4.12. Parallel Phone Detection

The ISModem<sup>®</sup> is able to detect when another telephone, modem, or other device is using the phone line. This allows the host to avoid interrupting another phone call when the phone line is already in use and to intelligently handle an interruption when the ISModem is using the phone line.

### 4.12.1. On-Hook Line-in-use Detection

When the ISModem is sharing the telephone line with other devices, it is important that it not interrupt a call in progress. To detect whether another device is using the shared telephone line, the host can use the ISModem to monitor the TIP-RING dc voltage with the line voltage sense (LVS) register (U6C, bits 15:8). The LVS bits have a resolution of 1 V per bit with an accuracy of approximately  $\pm 10\%$ . Bits 0 through 6 of this 8-bit signed twos complement number indicate the value of the line voltage, and the sign bit (bit 7) indicates the polarity of TIP and RING. The ISModem can also monitor the TIP-RING dc voltage using the LVCS register (U79, bits 4:0). See Figure 7 on page 18. See also the %Vn commands for automatic line-in-use detection.

### 4.12.2. Off-Hook Intrusion Detection

When the ISModem is off-hook, an algorithm is implemented in the ISModem to automatically monitor the TIP-RING loop current via the LVCS register. During the off-hook state, the LVCS register switches from representing the TIP-RING voltage to representing the TIP-RING current. See Figure 8 on page 19. Upon detecting an intrusion, the ISModem alerts the host of the condition via the INT pin.

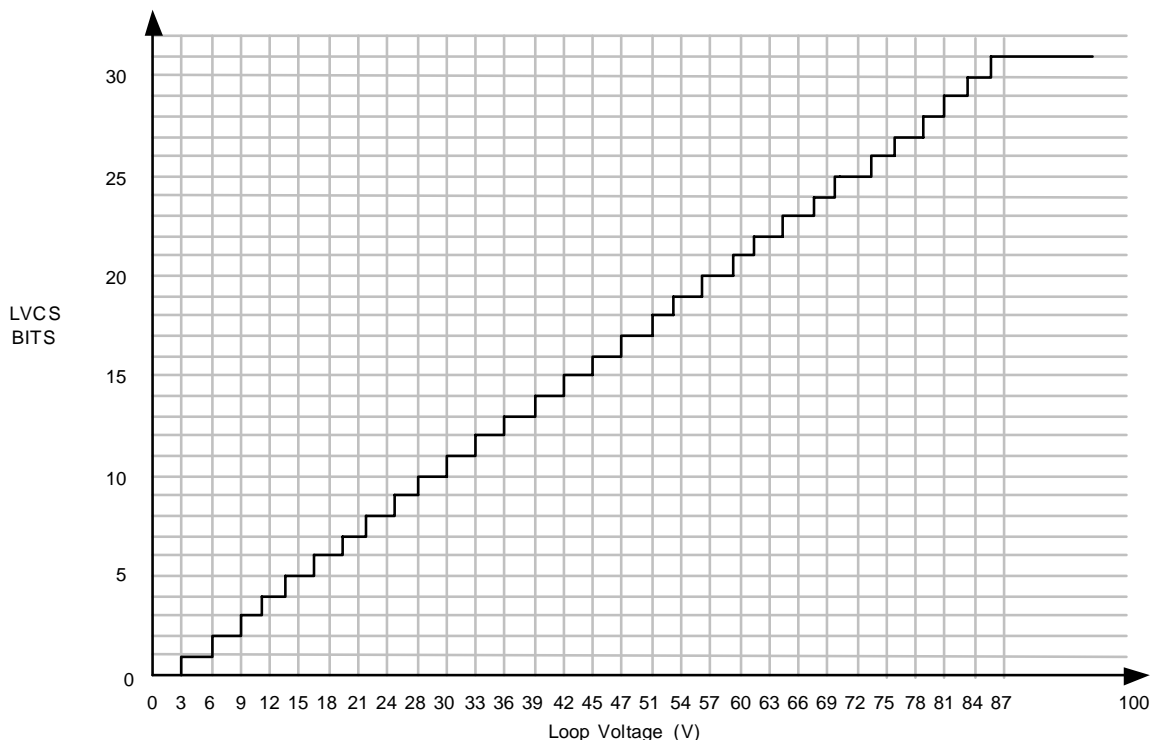

Figure 7. Loop Voltage

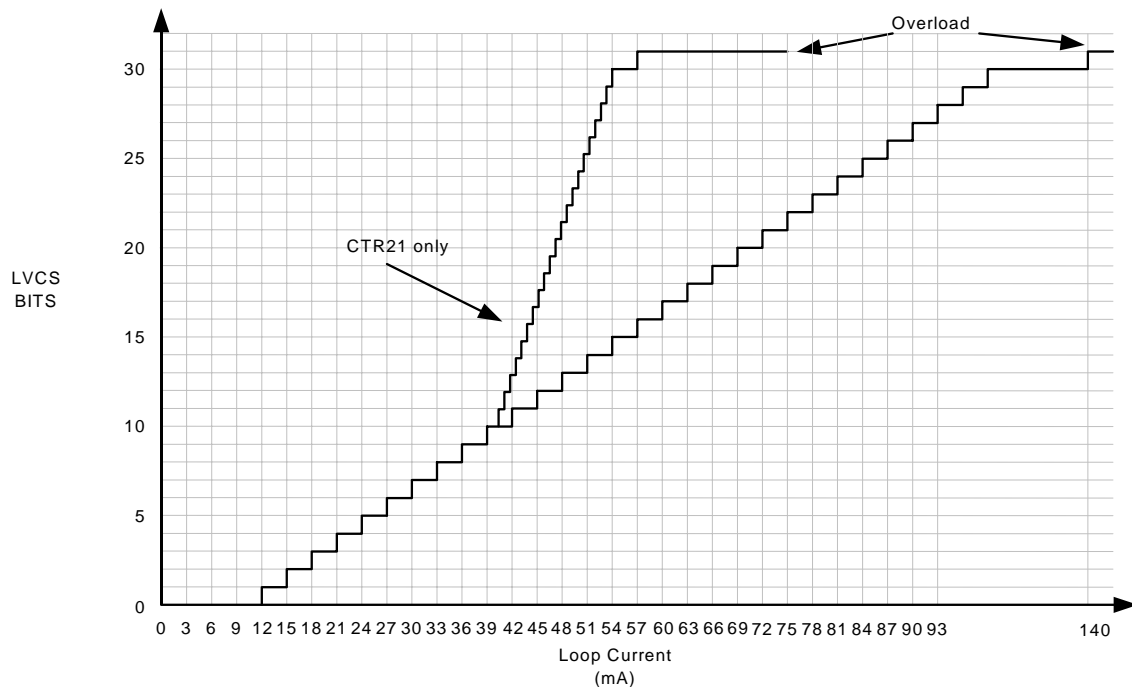

Figure 8. Loop Current

#### 4.13. Overcurrent Detection

The Si2457/34/15/04 includes an overcurrent detection feature that measures the loop current at a programmable time after the Si2457/34/15/04 goes off-hook. This allows the Si2457/34/15/04 to detect if it is connected to an improper telephone line. The overcurrent detection feature may be enabled by setting the OCDM bit (U70, bit 11). OHT (U77, bits 8:0) sets the delay after off-hook until the loop current is measured. See “AN93: Modem Designer’s Guide” for details.

#### 4.14. Global Operation

The Si2457/34/15/04 chipset contains an integrated silicon direct access arrangement (Silicon DAA) that provides a programmable line interface to meet international telephone line interface requirements. “AN93: Modem Designer’s Guide” gives the DAA register settings required to meet international PTT standards.

Additionally, the user-access registers (via the AT:U and AT:R commands) may be programmed for country-specific settings, such as dial tone, ring, ringback, and busy tone. See “AN93: Modem Designer’s Guide” for complete details.

#### 4.15. Firmware Upgrades

The Si2457/34/15/04 contains an on-chip program ROM that includes the firmware required for the features listed in this data sheet. In addition, the Si2457/34/15/04 contains on-chip program RAM to accommodate minor changes to the ROM firmware. This allows Silicon Labs to provide future firmware updates to optimize the characteristics of new modem designs and those already deployed in the field. See “AN93: Modem Designer’s Guide” for complete details.

#### 4.16. SMS / MMS Support

The Si2457/34/15/04 supports V.23 half-duplex modulation. This modulation provides the low-level functionality needed for SMS and MMS protocols. See “AN93: Modem Designer’s Guide” for complete details.

#### 4.17. Codec Interface (24-Pin Version Only)

In order to support a full range of voice and data applications, the Si2457/34/15/04 includes an optional serial interface that connects to an external voice codec (Si3000). See “AN93: Modem Designer’s Guide” for complete details.



## 4.18. EEPROM Interface (24-Pin Version Only)

The Si2457/34/15/04 supports an optional serial peripheral interface (SPI) bus serial EEPROM Mode 3 with a 16-bit (8–64 kbit range) address. Upon powerup, if a pulldown resistor  $\leq 10\text{ k}\Omega$  is placed between D6 (Si2457, pin 4) and GND (see Table 8), the ISOModem attempts to detect an EEPROM. The EEPROM is intended first for setting custom defaults, second for automatically loading firmware upgrades, and third to allow for user-defined AT command macros for use in custom AT commands or country codes. See “AN93: Modem Designer’s Guide” for complete details.

## 4.19. AT Commands

At powerup, the Si2457/34/15/04 is in the AT command mode. In command mode, the modem monitors the input (serial or parallel) checking constantly for a valid command (AT commands are described in Table 10.)

Table 10. Basic AT Command Set (Command Defaults in Bold)

Command	Action																				
\$	Display AT command mode settings.																				
A	Answer incoming call																				
A/	Re-execute last command. This is the only command not preceded by "AT" or followed by a <CR>.																				
Dn	<p>Dial</p> <p>The dial command, followed by 1 or more dial command modifiers, manually dials a phone number:</p> <table border="1"> <thead> <tr> <th>Modifier</th> <th>Function</th> </tr> </thead> <tbody> <tr> <td>! or &amp;</td> <td>Flash hook switch for FHT (U4F) ms (default: 500 ms)</td> </tr> <tr> <td>, or &lt;</td> <td>Pause before continuing for S8 seconds (default: 2 seconds)</td> </tr> <tr> <td>;</td> <td>Return to AT command mode</td> </tr> <tr> <td>@</td> <td>Wait for silence.</td> </tr> <tr> <td>G</td> <td> <p>Polarity reversal detect. By placing the "G" character in the dial string (i.e. ATDTG1), the Si2457/34/15/04 will monitor the telephone line for polarity reversals. If a busy tone is detected, the Si2457/34/15/04 will report "POLARITY REVERSAL" if a polarity reversal was detected or "NO POLARITY REVERSAL" if a polarity reversal was not detected. In each case, the result code is followed by "OK". If the S7 timeout occurs before a busy tone is detected, the Si2457/34/15/04 will report "NO CARRIER". Polarity reversal monitoring begins after the last digit is dialed and ends when the busy tone is detected or S7 timeout occurs.</p> <p><b>Note:</b> It is not possible to establish a modem connection when using this command.</p> </td> </tr> <tr> <td>L</td> <td>Redial last number.</td> </tr> <tr> <td>P</td> <td>Pulse (rotary) dialing—pulse digits: 0, 1, 2, 3, 4, 5, 6, 7, 8, 9</td> </tr> <tr> <td>T</td> <td>Tone (DTMF) dialing—DTMF digits: *, #, A, B, C, D, 0, 1, 2, 3, 4, 5, 6, 7, 8, 9.</td> </tr> <tr> <td>W</td> <td> <p>Wait for dial tone before continuing for S14 seconds (default: 12 seconds). Blind dialing modes X0, X1 and X3 do not affect the W command.</p> <p>If the DOP bit (U7A, bit 7) is set, the "ATDTW" command will cause the ISModem® to pause dialing and either report an "OK" if a dialtone is detected or "NO DIALTONE" if a dial tone is not detected.</p> </td> </tr> </tbody> </table>	Modifier	Function	! or &	Flash hook switch for FHT (U4F) ms (default: 500 ms)	, or <	Pause before continuing for S8 seconds (default: 2 seconds)	;	Return to AT command mode	@	Wait for silence.	G	<p>Polarity reversal detect. By placing the "G" character in the dial string (i.e. ATDTG1), the Si2457/34/15/04 will monitor the telephone line for polarity reversals. If a busy tone is detected, the Si2457/34/15/04 will report "POLARITY REVERSAL" if a polarity reversal was detected or "NO POLARITY REVERSAL" if a polarity reversal was not detected. In each case, the result code is followed by "OK". If the S7 timeout occurs before a busy tone is detected, the Si2457/34/15/04 will report "NO CARRIER". Polarity reversal monitoring begins after the last digit is dialed and ends when the busy tone is detected or S7 timeout occurs.</p> <p><b>Note:</b> It is not possible to establish a modem connection when using this command.</p>	L	Redial last number.	P	Pulse (rotary) dialing—pulse digits: 0, 1, 2, 3, 4, 5, 6, 7, 8, 9	T	Tone (DTMF) dialing—DTMF digits: *, #, A, B, C, D, 0, 1, 2, 3, 4, 5, 6, 7, 8, 9.	W	<p>Wait for dial tone before continuing for S14 seconds (default: 12 seconds). Blind dialing modes X0, X1 and X3 do not affect the W command.</p> <p>If the DOP bit (U7A, bit 7) is set, the "ATDTW" command will cause the ISModem® to pause dialing and either report an "OK" if a dialtone is detected or "NO DIALTONE" if a dial tone is not detected.</p>
Modifier	Function																				
! or &	Flash hook switch for FHT (U4F) ms (default: 500 ms)																				
, or <	Pause before continuing for S8 seconds (default: 2 seconds)																				
;	Return to AT command mode																				
@	Wait for silence.																				
G	<p>Polarity reversal detect. By placing the "G" character in the dial string (i.e. ATDTG1), the Si2457/34/15/04 will monitor the telephone line for polarity reversals. If a busy tone is detected, the Si2457/34/15/04 will report "POLARITY REVERSAL" if a polarity reversal was detected or "NO POLARITY REVERSAL" if a polarity reversal was not detected. In each case, the result code is followed by "OK". If the S7 timeout occurs before a busy tone is detected, the Si2457/34/15/04 will report "NO CARRIER". Polarity reversal monitoring begins after the last digit is dialed and ends when the busy tone is detected or S7 timeout occurs.</p> <p><b>Note:</b> It is not possible to establish a modem connection when using this command.</p>																				
L	Redial last number.																				
P	Pulse (rotary) dialing—pulse digits: 0, 1, 2, 3, 4, 5, 6, 7, 8, 9																				
T	Tone (DTMF) dialing—DTMF digits: *, #, A, B, C, D, 0, 1, 2, 3, 4, 5, 6, 7, 8, 9.																				
W	<p>Wait for dial tone before continuing for S14 seconds (default: 12 seconds). Blind dialing modes X0, X1 and X3 do not affect the W command.</p> <p>If the DOP bit (U7A, bit 7) is set, the "ATDTW" command will cause the ISModem® to pause dialing and either report an "OK" if a dialtone is detected or "NO DIALTONE" if a dial tone is not detected.</p>																				
En	Local DTE echo																				
E0	Disable																				
<b>E1</b>	<b>Enable</b>																				
Hn	Hook switch.																				
H0	Go on-hook (hang up modem).																				



**Table 10. Basic AT Command Set (Command Defaults in Bold) (Continued)**

Command	Action
H1	Go off-hook.
In	Identification and checksum.
I0	Display Si2457/34/15/04 revision code. B: Revision B C: Revision C, etc.
I1	Display Si2457/34/15/04 firmware revision code (numeric).
I3	Display line-side revision code. 18C = Si3018 revision C
I6	Display the ISOModem® model number. "2404" = Si2404 "2415" = Si2415 "2434" = Si2434 "2457" = Si2457
I7	Diagnostic results 1. See "AN93: Modem Designer's Guide" for details.
I8	Diagnostic results 2. See "AN93: Modem Designer's Guide" for details.
Ln	Speaker volume operation
L1	Low speaker volume
L2	Medium speaker volume
L3	High speaker volume
Mn	Speaker operation (via AOUT).
<b>M0</b>	<b>Speaker is always off.</b>
M1	Speaker is on while dialing and handshaking; off in data mode.
M2	Speaker is always on.
M3	Speaker is off while dialing, on during handshaking and retraining.
On	Return to data mode from Command mode operation.
O0	Return to data mode.
O1	Return to data mode and perform a full retrain (at any speed except 300 bps).
O2	Return to data mode and perform rate renegotiation.
Qn	Response mode.
<b>Q0</b>	<b>Enable result codes (see Table 14 on page 36)</b>
Q1	Disable result codes (enable quiet mode).
R	Initiate V.23 reversal.
Sn	S-register operation (see Table 15 on page 39).
S\$	List contents of all S registers.
Sn?	Display contents of S-register n.
Sn=x	Set S-register n to value x (where n and x are decimal values).
Vn	Result code type (see Table 14 on page 36).
V0	Numeric result codes.
<b>V1</b>	<b>Verbal result codes</b>

Table 10. Basic AT Command Set (Command Defaults in Bold) (Continued)

Command	Action
Xn	Call Progress Monitor (CPM)—This command controls which CPM signals are monitored and reported to the host from the Si2457/34/15/04. (See Table 14 on page 36.)
X0	Basic results; disable CPM—Blind dial (does not wait for dial tone). CONNECT message does not include speed.
X1	Extended results; disable CPM—Blind dial. CONNECT message includes speed.
X2	Extended results and detect dial tone only—Add dial tone detection to X1 mode. Does not blind dial.
X3	Extended results and detect busy only—Add busy tone detection to X1 mode.
<b>X4</b>	<b>Extended results, full CPM—Full CPM enabled, CONNECT message includes speed.</b>
X5	Extended results—Full CPM enabled including ringback detection. Adds ringback detection to X4 mode.
Yn	Long space disconnect—Modem hangs up after 1.5 seconds or more of continuous space while on-line.
<b>Y0</b>	<b>Disable.</b>
Y1	Enable.
Z	Hard Reset—This command is functionally equivalent to pulsing the RESET pin low. (See $t_{AT}$ in Table 6 on page 7.)
:E	Read from serial EEPROM.
:I	Interrupt Read—This command causes the ISOmodem® to report the lower 8 bits of the interrupt register I/O Control 0 (U70). The CID, OCD, PPD, and RI bits also are cleared, and the INT pin (INT bit in parallel mode) is deactivated on this read.
:M	Write to serial EEPROM.
:P	Program RAM Write—This command is used to upload firmware supplied by Silicon Labs to the Si2457/34/15/04. The format for this command is AT:Paaaa,xxxx,yyyy,... where aaaa is the first address in hexadecimal and xxxx,yyyy,... is data in hexadecimal. Only one :P command is allowed per AT command line. No other commands can be concatenated in the :P command line. This command is <i>only</i> for use with special files provided by Silicon Laboratories. Do not attempt to use this command for any other purpose.
:R	User-Access Register Read—This command allows the user to read from the user-access registers. (See pages page 42–page 60.) The format is “AT:Raa”, where aa = user-access address in hexadecimal. The “AT:R” command causes all the U- registers to be displayed.
:U	User-Access Register Write—This command allows the user to write to the 16-bit user-access registers. (See page page 42.) The format is “AT:Uaa,xxxx,yyyy,zzzz,...” where aa = user-access address in hexadecimal. xxxx = Data in hexadecimal to be written to location aa. yyyy = Data in hexadecimal to be written to location (aa + 1). zzzz = Data in hexadecimal to be written to location (aa + 2). etc.



**Table 10. Basic AT Command Set (Command Defaults in Bold) (Continued)**

Command	Action										
+DR=X	Data compression reporting. X <u>Mode</u> <b>0 Disabled</b> 1 Enabled If enabled, the intermediate result code is transmitted at the point after error control negotiation. The format of this result code is as follows: <table border="0" style="width: 100%;"> <tr> <td style="width: 30%;"><u>Result code</u></td> <td><u>Mode</u></td> </tr> <tr> <td>+DR:NONE</td> <td>Data compression is not in use</td> </tr> <tr> <td>+DR:V42B</td> <td>Rec. V.42bis is in use in both directions</td> </tr> <tr> <td>+DR:V42B RD</td> <td>Rec. V.42bis is in use in receive direction only</td> </tr> <tr> <td>+DR:V42B TD</td> <td>Rec. V.42bis is in use in transmit directions only</td> </tr> </table>	<u>Result code</u>	<u>Mode</u>	+DR:NONE	Data compression is not in use	+DR:V42B	Rec. V.42bis is in use in both directions	+DR:V42B RD	Rec. V.42bis is in use in receive direction only	+DR:V42B TD	Rec. V.42bis is in use in transmit directions only
<u>Result code</u>	<u>Mode</u>										
+DR:NONE	Data compression is not in use										
+DR:V42B	Rec. V.42bis is in use in both directions										
+DR:V42B RD	Rec. V.42bis is in use in receive direction only										
+DR:V42B TD	Rec. V.42bis is in use in transmit directions only										
+DS Options +DS = A +DS = A,B +DS = A,B,C +DS = A,B,C,D	Controls V.42bis data compression function. A Direction 0 No compression 1 Transmit only 2 Receive only <b>3 Both Directions</b> B Compression_negotiation <b>0 Do not disconnect if V.42 is not negotiated.</b> 1 Disconnect is V.42 is not negotiated. C Maximum dictionary size <b>512</b> D Maximum string size 6 to 250 (28 default)										
+ES Options +ES = A +ES = A,,C	Enable synchronous access mode. A Specifies the mode of operation when initiating a modem connection. D Disable synchronous access mode. 6 Enable synchronous access mode when connection is completed and data state is entered. B Specifies fallback mode of operation. This parameter should not be used. C Specifies the mode of operation when answer a modem connection. D Disable synchronous access mode. 8 Enable synchronous access mode when connection is completed and data state is entered.										



Table 10. Basic AT Command Set (Command Defaults in Bold) (Continued)

Command	Action
+ESA Options +ESA = A +ESA = A,B +ESA = A,B,C +ESA = A,B,C,E +ESA = A,B,C,E,F +ESA = A,B,C,E,F,G	Synchronous access mode control options <b>A</b> Specifies action taken if an underrun condition occurs during transparent sub-mode. <b>0</b> Modem transmits 8-bit SYN sequences on idle. <b>B</b> Specifies action taken if an underrun condition occurs after a flag during framed sub-mode <b>0</b> Modem transmits 8-bit HDLC flags on idle. <b>C</b> Specifies action taken if an underrun or overrun condition occurs after a non-flag during framed sub-mode. <b>0</b> Modem transmits abort on underrun in middle of frame. <b>1</b> Modem transmits flag on underrun in middle of frame and notifies host of underrun or overrun. <b>D</b> Specifies V.34 half duplex operation. This parameter should not be used. <b>E</b> Specifies CRC polynomial used while in framed sub-mode. <b>0</b> CRC generation checking disable. <b>1</b> 16-bit CRC generation and checking is performed by the modem. <b>F</b> Specifies NRZI encoding and decoding. <b>0</b> NRZI encoding and decoding disabled. <b>G</b> Specifies SYN. 255
+FCLASS = X	Class 1 Mode Enable for V.29 fast connect. <b>X</b> <u>Mode</u> <b>0</b> <b>Off</b> <b>1</b> Enables support for Class 1 mode for use in the V.29 fast connect mode.
+FRM = X	Class 1 Receive Carrier for V.29 fast connect. <b>X</b> <u>Mode</u> <b>2</b> Transmit V.21 (980 Hz) tone for longer than 100 ms, then send answer tone (2100/2225 Hz) for 200 ms. <b>95</b> V.29 short synchronous. <b>96</b> V.29 full synchronous.
+FTM = X	Class 1 Transmit Carrier for V.29 fast connect. <b>X</b> <u>Mode</u> <b>2</b> Transmit V.21 (980 Hz) tone. <b>53</b> Same as &T4, but transmit V.29 7200 bps. Data pattern set by S40 register. AT + FCLASS = 0 must be sent to restore the ISOmodem® to normal operation after test. <b>54</b> Same as &T4, but transmit V.29 9600 bps. Data pattern set by S40 register. AT + FCLASS = 0 must be sent to restore the ISOmodem to normal operation after test. <b>95</b> V.29 short synchronous. <b>96</b> V.29 full synchronous.



Table 10. Basic AT Command Set (Command Defaults in Bold) (Continued)

Command	Action
+GCI = X	Country settings - Automatically configure all registers for a particular country. <u>X</u> <u>Country</u> 0      Japan 9      Australia A      Austria F      Belgium 16      Brazil 1B      Bulgaria 20      Canada 26      China 27      Columbia 2E      Czech Republic 31      Denmark 35      Ecuador 3C      Finland 3D      France 42      Germany 46      Greece 50      Hong Kong 51      Hungary 53      India 57      Ireland 58      Israel 59      Italy 61      South Korea 69      Luxembourg 6C      Malaysia 73      Mexico 7B      Netherlands 7E      New Zealand 82      Norway 87      Paraguay 89      Philippines 8A      Poland 8B      Portugal 9C      Singapore 9F      South Africa A0      Spain A5      Sweden A6      Switzerland B8      Russia B4      United Kingdom <b>B5</b> <b>United States</b> FE      Taiwan <b>Note:</b> U-registers are configured to Silicon Laboratories' recommended values. The +GCI command resets the U-registers and the S7 and S6 S-registers to default values before setting country-specific values. Changes may be made by writing individual registers after sending the AT+GCI command. Refer to "AN93: Modem Designer's Guide" for details.
+GCI?	List current country code setting (response is: + GCI:<setting>)
+GCI = ?	List all possible country code settings.

Table 10. Basic AT Command Set (Command Defaults in Bold) (Continued)

Command	Action
+IFC Options +IFC = A +IFC = A,B	Specifies the flow control to be implemented. A Specifies the flow control method used by the host to control data from the modem 0 None 1 Local XON/OFF flow control. Does not pass XON/XOFF character to the remote modem. 2 Hardware flow control (RTS) B Specifies the flow control method used by the modem to control data from the host 0 None 1 Local XON/OFF flow control. 2 Hardware flow control (CTS).
+ITF Options +ITF = A +ITF = A,B +ITF = A,B,C	Transmit flow control threshold. A Threshold above which the modem will generate a flow off signal <0 to 511> bytes B Threshold below which the modem will generate a flow on signal <0 to 511> bytes C Polling interval for <EM><BNUM> indicator 0 to 300 in 10 msec units.
+MR = X	Modulation reporting control. <u>X</u> Mode <b>0</b> Disabled 1 Enabled If enabled, the intermediate result code is transmitted at the point during connect negotiation. The format of this result code is as follows: +MCR: <carrier> e.g. +MCR: V32B +MRR: <rate> e.g. +MRR: 14400
+MS Options +MS = A +MS = A,B +MS = A,B,C +MS = A,B,C,D +MS = A,B,C,D,E +MS = A,B,C,D,E,F	Modulation Selection. A Preferred modem carrier V21 ITU-T V.21 V22 ITU-T V.22 <b>V22B</b> <b>ITU-T V.22bis (default for Si2404)</b> V32 ITU-T V.32 <b>V32B</b> <b>ITU-T V.32bis (default for Si2415)</b> <b>V34</b> <b>ITU-T V.34 (default for Si2434)</b> <b>V90</b> <b>ITU-T V.90 (default for Si2457)</b> B Automatic modulation negotiation 0 Disabled <b>1 Enabled</b> C,D Min TX rate/Max TX rate are optional numeric values that specify the lowest value at which the DCE may establish a connection. If unspecified (set to 0), they are determined by the carrier and automode settings. E,F Min RX rate/Max RX rate are optional numeric values which specify the highest value at which the DCE may establish a connection. If unspecified (set to 0), they are determined by the carrier and automode settings.



**Table 10. Basic AT Command Set (Command Defaults in Bold) (Continued)**

Command	Action
+PCW = X	Controls the action to be taken upon detection of call waiting. <u>X</u> <u>Mode</u> 0    Toggle $\overline{RI}$ and collect type II Caller ID if enabled by +VCID. 1    Hang up. <b>2</b> <b>Ignore call waiting.</b>
+VCDT = X	Caller ID Type. <u>X</u> <u>Mode</u> <b>0</b> <b>After ring only</b> 1    Always on 2    UK 3    Japan
+VCID = X	Caller ID Enable. <u>X</u> <u>Mode</u> <b>0</b> <b>Off</b> 1    On—formatted 2    On—raw data format
+VCIDR?	Type II caller ID information — The Si2493 will display "+VCDIR:" followed by raw caller ID information including checksum.

## 4.20. Extended AT Commands

The extended AT commands are supported by the Si2457/34/15/04 and are described in Tables 11 through 13.

**Table 11. Extended AT& Command Set (Command Defaults in Bold)**

Command	Action
&\$	Display AT& current settings.
&D0	ESC is not used
&D1	<b>ESC escapes to command mode from data mode if also enabled by HES U70, bit 15.</b>
&D2	ESC assertion during a modem connection causes the modem to go on-hook and return to command mode.
&D3	ESC assertion causes ATZ command (reset and return OK result code).
&F	Restore factory default settings.
&Gn	Line connection rate limit—This command sets an upper limit on the line speed that the Si2457/34/15/04 can connect. Note that the &Hn commands may limit the line speed as well (&Gn not used for &H0 or &H1). Not all modulations support rates given by &G. Any improper setting will be ignored.
&G3	1200 bps max
&G4	<b>2400 bps max (default for Si2404)</b>
&G5	4.8 kbps max
&G6	7.2 kbps max
&G7	9.6 kbps max
&G8	12 kbps max
<b>&amp;G9</b>	<b>14.4 kbps max (default for Si2415)</b>
&G10	16.8 kbps max
&G11	19.2 kbps max
&G12	21.6 kbps max
&G13	24 kbps max
&G14	26.4 kbps max
&G15	28.8 kbps max
&G16	31.2 kbps max
<b>&amp;G17</b>	<b>33.6 kbps max (default for Si2457 and Si2434)</b>
&Hn	Switched network handshake mode—&Hn commands must be on a separate command line from ATD, ATA, or ATO commands.
<b>&amp;H0</b>	<b>V.90 with automatic fallback (56 kbps to 300 bps) (default for Si2457)</b>
&H1	V.90 only (56 kbps to 28 kbps)
<b>&amp;H2</b>	<b>V.34 with automatic fallback (33.6 kbps to 300 bps) (default for Si2434)</b>
&H3	V.34 only (33.6 kbps to 2400 bps)



**Table 11. Extended AT& Command Set (Command Defaults in Bold) (Continued)**

Command	Action
<b>&amp;H4</b>	<b>ITU-T V.32bis with automatic fallback (14.4 kbps to 300 bps) (default for Si2415)</b>
&H5	ITU-T V.32bis only (14.4 kbps to 4800 bps)
&H6	ITU-T V.22bis only (2400 bps or 1200 bps)
&H7	ITU-T V.22 only (1200 bps)
&H8	Bell 212 only (1200 bps)
&H9	Bell 103 only (300 bps)
&H10	ITU-T V.21 only (300 bps)
&H11	V.23 (1200/75 bps)
&Pn	Japan pulse dialing
&P0	Configure Si2457/34/15/04 for 10 pulse-per-second pulse dialing. For Japan.
&P1	Configure Si2457/34/15/04 for 20 pulse-per-second pulse dialing. For Japan.
&Tn	Test mode
&T0	Cancel test mode (Escape to command mode to issue AT&T0). This command will also report the number of bit errors encountered on the previous &T4 or &T5 test.
&T2	Initiate ITU-T V.54 (ANALOOP) test. Modulation set by &H AT command. Test loop is through the DSP (Si2457/34/15/04 device) only. ISModem® echoes data from TX pin (Register 0 in parallel mode) back to RX pin (Register 0 in parallel mode).
&T3	Initiate ITU-T V.54 (ANALOOP) test. Modulation set by &H AT command. Test loop is through the DSP (Si2457/34/15/04), DAA interface section (Si2457/34/15/04), DAA interface (Si3018), and analog hybrid circuit (Si3018). ISModem echoes data from TX pin (Register 0 in parallel mode) back to RX pin (Register 0 in parallel mode). Phone line termination required as in Figure 1. To test only the link operation, the hybrid and AFE codec can be removed from the test loop by setting the DL bit (U62, bit 1).
&T4	Initiate transmit as originating modem with automatic data generation. Modulation, data rate, and symbol rate are set by &H, &G, and S41. Data pattern is set by the S40 register. Continues until the ATH command is sent after an escape into command mode. Data is also demodulated as in ANALOOP, and any bit errors are counted to be displayed after the test using &T0.
&T5	Initiate transmit as answering modem with automatic data generation. Modulation, data rate, and symbol rate are set by &H, &G, and S41. Data pattern is set by the S40 register. Continues until the ATH command is sent after an escape into command mode. Data is also demodulated as in ANALOOP, and any bit errors are counted to be displayed after the test using &T0.
&T6	Compute checksum for firmware-upgradeable section of program memory. If no firmware upgrade is installed, &T6 returns 0x4474.
&Xn	Automatic determination of telephone line type.
&X0	Abort &x1 or &x2 command.

Table 11. Extended AT&amp; Command Set (Command Defaults in Bold) (Continued)

Command	Action
&X1	Automatic determination of telephone line type. Result code: WXYZn W: 0 = line supports DTMF dialing. 1 = line is pulse dial only. X: 0 = line supports 20 pps dialing. 1 = line supports 10 pps dialing only. Y: 0 = extension network present (PBX). 1 = outside line (PSTN) connected directly. Z: 0 = continuous dialtone. 1 = make-break dialtone. n: 0–9 (number required for outside line if Y = 0). <b>Note:</b> The initial number attempted for an outside line is controlled in S51.
&X2	Same as &X1, but Y result (PBX) is not tested.
*Y2A	Produce a constant answer tone (ITU-T) and return to command mode. The answer tone continues until the ATH command is received or the S7 timer expires.
&Z	Enter low-power wake-on-ring mode.

Table 12. Extended AT% Command Set (Command Defaults in Bold)

Command	Action
%%\$	Display AT% command settings.
%B	Report blacklist. See also S42 register.
%Cn	Data compression
%C0	Disable V.42bis and MNP5 data compression
<b>%C1</b>	<b>Enable V.42bis in transmit and receive paths. If MNP is selected (N2), then %C1 enables MNP5 in transmit and receive paths.</b>
%C2	Enable V.42bis in transmit path only.
%C3	Enable V.42bis in receive path only.
%On	Answer mode.
<b>%O1</b>	<b>Si2457/34/15/04 will auto-answer a call in answer mode.</b>
%O2	Si2457/34/15/04 will auto-answer a call in originate mode.
%Vn	Automatic Line Status Detection. After the %V1 and %V2 commands are issued, the Si2457/34/15/04 will automatically check the telephone connection for whether or not a line is present. If a line is present, the Si2457/34/15/04 will automatically check if the line is already in use. Finally, the Si2457/34/15/04 will check line status both before going off-hook and again before dialing. %V1 uses the fixed method, and %V2 uses the adaptive method. %V0 (default) disables this feature.
<b>%V0</b>	<b>Disable automatic line-in-use detection.</b>



**Table 12. Extended AT% Command Set (Command Defaults in Bold) (Continued)**

Command	Action								
<p>%V1</p>	<p>Automatic Line Status Detection—Fixed Method.            Description: Before going off-hook with the ATD, ATO, or ATA commands, the Si2457/34/15/04 compares the line voltage (via LVCS) to registers NOLN (U83) and LIUS (U84):</p> <table border="0"> <tr> <td><u>Loop Voltage</u></td> <td><u>Action</u></td> </tr> <tr> <td><math>0 \leq LVCS \leq NOLN</math></td> <td>Report "NO LINE" and remain on-hook.</td> </tr> <tr> <td><math>NOLN \leq LVCS \leq LIUS</math></td> <td>Report "LINE IN USE" and remain on-hook.</td> </tr> <tr> <td><math>LIUS \leq LVCS</math></td> <td>Go off-hook and establish a modem connection.</td> </tr> </table> <p>Once the call has begun, the off-hook intrusion algorithm (described in "4.12.2. Off-Hook Intrusion Detection" on page 18) operates normally. In addition, the Si2457/34/15/04 will report "NO LINE" if the telephone line is completely disconnected. If the HOI bit (U77, bit 11) is set, "LINE IN USE" is reported upon intrusion.</p>	<u>Loop Voltage</u>	<u>Action</u>	$0 \leq LVCS \leq NOLN$	Report "NO LINE" and remain on-hook.	$NOLN \leq LVCS \leq LIUS$	Report "LINE IN USE" and remain on-hook.	$LIUS \leq LVCS$	Go off-hook and establish a modem connection.
<u>Loop Voltage</u>	<u>Action</u>								
$0 \leq LVCS \leq NOLN$	Report "NO LINE" and remain on-hook.								
$NOLN \leq LVCS \leq LIUS$	Report "LINE IN USE" and remain on-hook.								
$LIUS \leq LVCS$	Go off-hook and establish a modem connection.								
<p>%V2</p>	<p>Automatic Line Status Detection—Adaptive Method.            Description: Before going off-hook with the ATD, ATO, or ATA commands, the Si2457/34/15/04 compares the line voltage (via LVCS) to the NLIU (U85) register:</p> <table border="0"> <tr> <td><u>Loop Voltage</u></td> <td><u>Action</u></td> </tr> <tr> <td><math>0 \leq LVCS \leq (0.0625 \times NLIU)</math></td> <td>Report "NO LINE" and remain on-hook.</td> </tr> <tr> <td><math>(0.0625 \times NLIU) &lt; LVCS \leq (0.85 \times NLIU)</math></td> <td>Report "LINE IN USE" and remain on-hook.</td> </tr> <tr> <td><math>(0.85 \times NLIU) &lt; LVCS</math></td> <td>Go off-hook and establish a modem connection.</td> </tr> </table> <p>The NLIU register is updated every 1 ms with the minimum non-zero value of LVCS in the last 30 ms. This allows the Si2457/34/15/04 to eliminate errors due to 50/60 Hz interference and also adapt to relatively slow change in the on-hook dc reference value on the telephone line. This algorithm does not allow any non-zero values for NLIU below 0x0007. The host may also initialize NLIU prior to issuing the %V2 command. Once the call has begun, the off-hook intrusion algorithm (described in "4.12.2. Off-Hook Intrusion Detection" on page 18) operates normally. In addition, the Si2457/34/15/04 will report "NO LINE" if the telephone line is completely disconnected. If the HOI (U77, bit 11) bit is set, "LINE IN USE" is reported upon intrusion.</p>	<u>Loop Voltage</u>	<u>Action</u>	$0 \leq LVCS \leq (0.0625 \times NLIU)$	Report "NO LINE" and remain on-hook.	$(0.0625 \times NLIU) < LVCS \leq (0.85 \times NLIU)$	Report "LINE IN USE" and remain on-hook.	$(0.85 \times NLIU) < LVCS$	Go off-hook and establish a modem connection.
<u>Loop Voltage</u>	<u>Action</u>								
$0 \leq LVCS \leq (0.0625 \times NLIU)$	Report "NO LINE" and remain on-hook.								
$(0.0625 \times NLIU) < LVCS \leq (0.85 \times NLIU)$	Report "LINE IN USE" and remain on-hook.								
$(0.85 \times NLIU) < LVCS$	Go off-hook and establish a modem connection.								





Table 13. Extended AT\ Command Set (Command Defaults in Bold)

Command	Action
\\$	Display AT\ command settings.
\Bn	Character length will be automatically set in autobaud mode
\B0	6N1—six data bits, no parity, one stop bit, one start bit, eight bits total (\N0 only) <sup>1</sup>
\B1	7N1—seven data bits, no parity, one stop bit, one start bit, nine bits total (\N0 only) <sup>1</sup>
\B2	7P1—seven data bits, parity optioned by \P, one stop bit, one start bit, 10 bits total
<b>\B3</b>	<b>8N1—eight data bits, no parity, one stop bit, one start bit, 10 bits total</b>
\B5	8P1—eight data bits, parity optioned by \P, one stop bit, one start bit, 11 bits total (\N0 only)
\B6	8X1—eight data bits, one escape bit, one stop bit, one start bit, 11 bits total (enables ninth-bit escape mode)
\Nn	Asynchronous protocol
\N0	Wire mode (no error correction, no compression)
\N2	MNP reliable mode. The Si2457/34/15/04 attempts to connect with the MNP protocol. If unsuccessful, the call is dropped.
<b>\N3</b>	<b>V.42 auto-reliable—The Si2457/34/15/04 attempts to connect with the V.42 protocol. If unsuccessful, the MNP protocol is attempted. If unsuccessful, wire mode is attempted.</b>
\N4	V.42 (LAPM) reliable mode (or drop call)—Same as \N3 except that the Si2457/34/15/04 drops the call instead of connecting in MNP or wire mode.
\N5	V.42 and MNP reliable mode—The Si2457/34/15/04 attempts to connect with V.42. If unsuccessful, MNP is attempted. If MNP is unsuccessful, the call is dropped.
\Pn	Parity type will be automatically set in autobaud mode
<b>\P0</b>	<b>Even</b>
\P1	Space <sup>1</sup>
\P2	Odd
\P3	Mark <sup>1</sup>
\Qn	Modem-to-DTE flow control
\Q0	Disable all flow control—This may only be used if the DTE speed and the VF speed are guaranteed to match throughout the call.
<b>\Q2</b>	<b>Use CTS only</b>
<b>Notes:</b>	
1. When in autobaud mode, \B0, \B1, and \P1 will not be detected automatically. The combination of \B2 and \P3 will be detected. This is compatible with seven data bits, no parity, two stop bits. Seven data bits, no parity, one stop bit may be forced by sending AT\T17\B1.	
2. The autobaud feature does not detect this rate.	



Table 13. Extended AT Command Set (Command Defaults in Bold) (Continued)

Command	Action
\Q3	Use RTS/CTS
\Q4	Use XON/XOFF flow control for modem-to-DTE interface. Does not enable modem-to-modem flow control.
\Tn	DTE rate—Change DTE rate. When the Si2457/34/15/04 is configured in autobaud mode (default), \T0 through \T15 will lock the new baud rate and disable autobaud. On the 24-pin version, the ISO-modem® is not in autobaud mode (pin 18 low on powerup), the result code "OK" is sent at the old DTE rate. Subsequent commands must be sent at the new rate.
\T0	300 bps
\T1	600 bps
\T2	1200 bps
\T3	2400 bps
\T4	4800 bps
\T5	7200 bps
\T6	9600 bps
\T7	12.0 kbps <sup>2</sup>
\T8	14.4 kbps
\T9	19.2 kbps
\T10	38.4 kbps
\T11	57.6 kbps
\T12	115.2 kbps
\T13	230.4 kbps
\T14	245.760 kbps <sup>2</sup>
\T15	307.200 kbps
<b>\T16</b>	<b>Autobaud on</b>
\T17	Autobaud off; lock at current baud rate.
\U	Serial mode—causes a low pulse (25 ms) on $\overline{RI}$ and $\overline{DCD}$ . $\overline{INT}$ to be the inverse of ESC. $\overline{RTS}$ to be inverse of CTS. Parallel mode—causes a low pulse (25 ms) on $\overline{INT}$ . This command terminates with a $\overline{RESET}$ .
<b>Notes:</b>	
<ol style="list-style-type: none"> <li>When in autobaud mode, \B0, \B1, and \P1 will not be detected automatically. The combination of \B2 and \P3 will be detected. This is compatible with seven data bits, no parity, two stop bits. Seven data bits, no parity, one stop bit may be forced by sending AT\T17\B1.</li> <li>The autobaud feature does not detect this rate.</li> </ol>	

**Table 13. Extended AT Command Set (Command Defaults in Bold) (Continued)**

<b>Command</b>	<b>Action</b>
\n	Connect message type
<b>\V0</b>	<b>Report connect message and protocol message</b>
\V2	Report connect message only (exclude protocol message)
\V4	Report connect and protocol message with both upstream and downstream connect rates.
<b>Notes:</b> <ol style="list-style-type: none"><li>1. When in autobaud mode, \B0, \B1, and \P1 will not be detected automatically. The combination of \B2 and \P3 will be detected. This is compatible with seven data bits, no parity, two stop bits. Seven data bits, no parity, one stop bit may be forced by sending AT\T17\B1.</li><li>2. The autobaud feature does not detect this rate.</li></ol>	



Table 14. Result Codes

Numeric	Meaning	Verbal Response	X0	X1	X2	X3	X4	X5
0	Command was successful	OK	X	X	X	X	X	X
1	Link established at 300 bps or higher	CONNECT	X	X	X	X	X	X
2	Incoming ring detected	RING	X	X	X	X	X	X
3	Link dropped	NO CARRIER	X	X	X	X	X	X
4	Command failed	ERROR	X	X	X	X	X	X
5	Link establish at 1200	CONNECT 1200		X	X	X	X	X
6	Dial tone not present	NO DIALTONE			X		X	X
7	Line busy	BUSY				X	X	X
8	Remote not answering	NO ANSWER	X	X	X	X	X	X
9	Ringback detected	RINGING						X
10	Link established at 2400	CONNECT 2400		X	X	X	X	X
11	Link established at 4800	CONNECT 4800 <sup>1</sup>		X	X	X	X	X
12	Link established at 9600	CONNECT 9600 <sup>1</sup>		X	X	X	X	X
14	Link established at 19200	CONNECT 19200 <sup>1</sup>		X	X	X	X	X
15	Link established at 7200	CONNECT 7200 <sup>1</sup>		X	X	X	X	X
16	Link established at 12000	CONNECT 12000 <sup>1</sup>		X	X	X	X	X
17	Link established at 14400	CONNECT 14400 <sup>1</sup>		X	X	X	X	X
18	Link established at 16800	CONNECT 16800 <sup>2</sup>		X	X	X	X	X
19	Link established at 21600	CONNECT 21600 <sup>2</sup>		X	X	X	X	X
20	Link established at 24000	CONNECT 24000 <sup>2</sup>		X	X	X	X	X
21	Link established at 26400	CONNECT 26400 <sup>2</sup>		X	X	X	X	X
22	Link established at 28800	CONNECT 28800 <sup>2</sup>		X	X	X	X	X
23	Link established at 31200	CONNECT 31200 <sup>2</sup>		X	X	X	X	X
24	Link established at 33600	CONNECT 33600 <sup>2</sup>		X	X	X	X	X
30	Caller ID mark detected	CIDM	X	X	X	X	X	X
31	Hookswitch flash detected	FLASH	X	X	X	X	X	X
32	UK CID State Tone Alert Signal detected	STAS	X	X	X	X	X	X
33	Overcurrent condition	X <sup>2</sup>	X	X	X	X	X	X
40	Blacklist is full	BLACKLIST FULL (enabled via S42 register)	X	X	X	X	X	X
41	Attempted number is black-listed.	BLACKLISTED (enabled via S42 register)	X	X	X	X	X	X
42	No phone line present	NO LINE (enabled via %Vn commands)	X	X	X	X	X	X

**Notes:**

1. This message is only supported on the Si2457, Si2434, and Si2415.
2. This message is only supported on the Si2457 and Si2434.
3. X is the only verbal response code that does not follow the <CR><LF>Result Code<CR><LF> standard. There is no leading <CR><LF>.
4. This message is only supported on the Si2457.



Table 14. Result Codes (Continued)

Numeric	Meaning	Verbal Response	X0	X1	X2	X3	X4	X5
43	Telephone line is in use	LINE IN USE (enabled via %Vn commands)	X	X	X	X	X	X
44	A polarity reversal was detected	POLARITY REVERSAL (enabled via G modifier)	X	X	X	X	X	X
45	A polarity reversal was NOT detected	NO POLARITY REVERSAL (enabled via G modifier)	X	X	X	X	X	X
52	Link established at 56000	CONNECT 56000 <sup>4</sup>		X	X	X	X	X
60	Link established at 32000	CONNECT 32000 <sup>4</sup>		X	X	X	X	X
61	Link established at 48000	CONNECT 48000 <sup>4</sup>		X	X	X	X	X
63	Link established at 28000	CONNECT 28000 <sup>4</sup>		X	X	X	X	X
64	Link established at 29333	CONNECT 29333 <sup>4</sup>		X	X	X	X	X
65	Link established at 30666	CONNECT 30666 <sup>4</sup>		X	X	X	X	X
66	Link established at 33333	CONNECT 33333 <sup>4</sup>		X	X	X	X	X
67	Link established at 34666	CONNECT 34666 <sup>4</sup>		X	X	X	X	X
68	Link established at 36000	CONNECT 36000 <sup>4</sup>		X	X	X	X	X
69	Link established at 37333	CONNECT 37333 <sup>4</sup>		X	X	X	X	X
70	No protocol	PROTOCOL: NONE	Set with \V0 command.					
75	Link established at 75	CONNECT 75		X	X	X	X	X
77	V.42 protocol	PROTOCOL: V42	Set with \V0 command.					
79	V.42bis protocol	PROTOCOL: V42bis	Set with \V0 command.					
80	MNP2 protocol	PROTOCOL: ALTERNATE, + CLASS 2	Set with \V command.					
81	MNP3 protocol	PROTOCOL: ALTERNATE, + CLASS 3	Set with \V command.					
82	MNP4 protocol	PROTOCOL: ALTERNATE, + CLASS 4	Set with \V command.					
83	MNP5 protocol	PROTOCOL: ALTERNATE, + CLASS 5		X	X	X	X	X
90	Link established at 38666	CONNECT 38666 <sup>4</sup>		X	X	X	X	X
91	Link established at 40000	CONNECT 40000 <sup>4</sup>		X	X	X	X	X
92	Link established at 41333	CONNECT 41333 <sup>4</sup>		X	X	X	X	X
93	Link established at 42666	CONNECT 42666 <sup>4</sup>		X	X	X	X	X
94	Link established at 44000	CONNECT 44000 <sup>4</sup>		X	X	X	X	X
95	Link established at 45333	CONNECT 45333 <sup>4</sup>		X	X	X	X	X
96	Link established at 46666	CONNECT 46666 <sup>4</sup>		X	X	X	X	X
97	Link established at 49333	CONNECT 49333 <sup>4</sup>		X	X	X	X	X
98	Link established at 50666	CONNECT 50666 <sup>4</sup>		X	X	X	X	X

**Notes:**

1. This message is only supported on the Si2457, Si2434, and Si2415.
2. This message is only supported on the Si2457 and Si2434.
3. X is the only verbal response code that does not follow the <CR><LF>Result Code<CR><LF> standard. There is no leading <CR><LF>.
4. This message is only supported on the Si2457.



**Table 14. Result Codes (Continued)**

Numeric	Meaning	Verbal Response	X0	X1	X2	X3	X4	X5
99	Link established at 52000	CONNECT 52000 <sup>4</sup>		X	X	X	X	X
100	Link established at 53333	CONNECT 53333 <sup>3</sup>		X	X	X	X	X
101	Link established at 54666	CONNECT 54666 <sup>3</sup>		X	X	X	X	X
102	DTMF dial attempted on a pulse dial only line	UN-OBTAINABLE NUMBER	X	X	X	X	X	X

**Notes:**

1. This message is only supported on the Si2457, Si2434, and Si2415.
2. This message is only supported on the Si2457 and Si2434.
3. X is the only verbal response code that does not follow the <CR><LF>Result Code<CR><LF> standard. There is no leading <CR><LF>.
4. This message is only supported on the Si2457.

The connect messages shown in Table 14 are sent when link negotiation is complete.

## 5. S-Registers

The S command allows reading ( $S_n?$ ) or writing ( $S_n = x$ ) the S-registers. The S-registers store values for functions that typically are rarely changed, such as timers or counters, and the ASCII values of control characters, such as carriage return. Table 15 summarizes the S-register set.

**Table 15. S-Register Description**

Definition				
S-Register (Decimal)	Function	Default (Decimal)	Range	Units
0	Automatic answer—Number of rings the Si2457/34/15/04 must detect before answering a call. 0 disables auto answer.	0	0–255	Rings
1	Ring counter.	0	0–255	Rings
2	ESC code character.	43 (+)	0–255	ASCII
3	Carriage return character.	13 (CR)	0–255	ASCII
4	Linefeed character.	10 (LF)	0–255	ASCII
5	Backspace character.	08 (BS)	0–255	ASCII
6	Dial tone wait timer—Number of seconds the Si2457/34/15/04 waits before blind dialing. Only applicable if blind dialing is enabled (X0, X1, X3).	02	0–255	seconds
7	Carrier wait timer—Number of seconds the Si2457/34/15/04 waits for carrier before timing out. This register also sets the number of seconds the modem waits for ringback when originating a call before hanging up. This register also sets the number of seconds the answer tone will continue while using the AT*Y2A command.	80	0–255	seconds
8	Dial pause timer for , and < dial command modifiers.	02	0–255	seconds
9	Carrier presence timer—Time after a loss of carrier that a carrier must be detected before reactivating DCD. S9 is referred to as “carrier loss debounce time.”	06	1–255	0.1 second
10	Carrier loss timer—Time the carrier must be lost before the Si2457/34/15/04 disconnects. Setting 255 disables disconnect entirely. If S10 is less than S9, even a momentary loss of carrier causes a disconnect.	14	1–255	0.1 second
12	Escape code guard timer—Minimum guard time required before and after “+++” for the Si2457/34/15/04 to recognize a valid escape sequence.	50	1–255	0.02 second
14	Wait for dial tone delay value (in relation to the W dial modifier). Starts when “W” is executed in the dial string.	12	0–255	seconds



Table 15. S-Register Description (Continued)

Definition				
S-Register (Decimal)	Function	Default (Decimal)	Range	Units
24	Sleep Inactivity Time—Sets the time that the modem operates in normal power mode with no activity on the serial port, parallel port, or telephone line before entering low-power sleep mode. This feature is disabled if the timer is set to 0.	0	0–255	seconds
30	Disconnect Activity Timer—Sets the length of time that the modem stays online before disconnecting with no activity on the serial port, parallel port, or telephone line (Ring, hookswitch flash, or caller ID). This feature is disabled if set to 0.	0	0–255	minutes
38	Hang Up Delay Time—Maximum delay between receipt of ATH0 command and hang up. If time out occurs before all data can be sent, the NO CARRIER (3) result code is sent (operates in V.42 mode only). “OK” response is sent if all data is transmitted before timeout. S38 = 255 disables timeout and modem disconnects only if data is successfully sent or carrier is lost.	20	0–255	seconds
40	Data Pattern—Data pattern generated during &T4 and &T5 transmit tests. <b>0 = All spaces (0s)</b> 1 = All marks (1s) 2 = Random data	0	0–2	
41	V.34 symbol rate - Symbol rate for V.34 when using the &T4 and &T5 commands. <b>0 = 2400 symbols/second</b> 1 = 2743 symbols/second 2 = 2800 symbols/second 3 = 3000 symbols/second 4 = 3200 symbols/second 5 = 3429 symbols/second A valid combination of symbol rate (S41) and data rate (&G) must be selected. <b><u>Symbol Rate</u>    <u>Allowable Data Rates</u></b> 2400            2400–21600 2743            4800–26400 2800            4800–26400 3000            4800–28800 3200            4800–31200 3429            4800–33600	0	0–5	



Table 15. S-Register Description (Continued)

Definition				
S-Register (Decimal)	Function	Default (Decimal)	Range	Units
42	Blacklisting—The Si2457/34/15/04 will not dial the same number more than two times in three minutes. An attempt to dial a third time within three minutes will result in a “BLACKLISTED” result code. If the blacklist memory is full, any dial to a new number will result in a “BLACKLIST FULL” result code. Numbers are added to the blacklist only if the modem connection fails. The %B command will list the numbers on the blacklists. <b>0 = disabled</b> 1 = enabled	0 (disabled)	0–1	
43	Dial Attempts to Blacklist. When blacklisting is enabled with S42, this value controls the number of dial attempts that will result in a number being blacklisted.	4	0–4	—
44	Blacklist Timer. Period during which blacklisting is active.	180	0–255	seconds
50	Minimum on-hook time—Modem will remain on-hook for S50 seconds. Any attempt to go off-hook will be delayed until this timer expires.	3	0–255	seconds
51	Number to start checking for an outside line on a PBX. See &X command for details.	1	0–9	—



## 6. User-Access Registers (U-Registers)

The :U AT command is used to write these 16-bit U-registers, and the :R command is used to read them. U-registers are identified by a hexadecimal (hex) address.

**Table 16. U-Register Description**

Register	Name	Description	Default
U00	DT1A0	DT1 registers set the coefficients for stage 1 of the Dial Tone Detect filter. Default is for FCC countries. See "AN93: Modem Designer's Guide" for other country settings.	0x0800
U01	DT1B1		0x0000
U02	DT1B2		0x0000
U03	DT1A2		0x0000
U04	DT1A1		0x0000
U05	DT2A0	Dial tone detect filters stage 2 biquad coefficients.	0x00A0
U06	DT2B1		0x6EF1
U07	DT2B2		0xC4F4
U08	DT2A2		0xC000
U09	DT2A1		0x0000
U0A	DT3A0	Dial tone detect filters stage 3 biquad coefficients.	0x00A0
U0B	DT3B1		0x78B0
U0C	DT3B2		0xC305
U0D	DT3A2		0x4000
U0E	DT3A1		0xB50A
U0F	DT4A0	Dial tone detect filters stage 4 biquad coefficients.	0x0400
U10	DT4B1		0x70D2
U11	DT4B2		0xC830
U12	DT4A2		0x4000
U13	DT4A1		0x80E2
U14	DTK	Dial tone detect filter output scaler.	0x0009
U15	DTON	Dial tone detect ON threshold.	0x00A0
U16	DTOF	Dial tone detect OFF threshold.	0x0070

Table 16. U-Register Description (Continued)

Register	Name	Description	Default
U17	BT1A0	BT1 registers set the coefficients for stage 1 of the Busy Tone Detect filter. Default is for FCC countries. See "AN93: Modem Designer's Guide" for other country settings.	0x0800
U18	BT1B1		0x0000
U19	BT1B2		0x0000
U1A	BT1A2		0x0000
U1B	BT1A1		0x0000
U1C	BT2A0	Busy tone detect filter stage 2 biquad coefficients.	0x00A0
U1D	BT2B1		0x6EF1
U1E	BT2B2		0xC4F4
U1F	BT2A2		0xC000
U20	BT2A1		0x0000
U21	BT3A0	Busy tone detect filter stage 3 biquad coefficients.	0x00A0
U22	BT3B1		0x78B0
U23	BT3B2		0xC305
U24	BT3A2		0x4000
U25	BT3A1		0xB50A
U26	BT4A0	Busy tone detect filter stage 4 biquad coefficients.	0x0400
U27	BT4B1		0x70D2
U28	BT4B2		0xC830
U29	BT4A2		0x4000
U2A	BT4A1		0x80E2
U2B	BTK	Busy tone detect filter output scaler.	0x0009
U2C	BTON	Busy tone detect ON threshold.	0x00A0
U2D	BTOF	Busy tone detect OFF threshold.	0x0070
U2E	BMTT	Busy cadence minimum total time in seconds multiplied by 7200. See "AN93: Modem Designer's Guide" for details.	0x0870
U2F	BDLT	Busy cadence delta in seconds multiplied by 7200.	0x25F8
U30	BMOT	Busy cadence minimum on time in seconds multiplied by 7200.	0x0438
U31	RMTT	Ringback cadence minimum total time in seconds multiplied by 7200.	0x4650
U32	RDLT	Ringback cadence delta in seconds multiplied by 7200.	0xEF10



Table 16. U-Register Description (Continued)

Register	Name	Description	Default
U33	RMOT	Ringback cadence minimum on time in seconds multiplied by 7200.	0x1200
U34	DTWD	Window to look for dialtone in seconds multiplied by 1000.	0x1B58
U35	DMOT	Minimum dialtone on time in seconds multiplied by 7200.	0x2D00
U37	PD0	Number of pulses to dial 0.	0x000A
U38	PD1	Number of pulses to dial 1.	0x0001
U39	PD2	Number of pulses to dial 2.	0x0002
U3A	PD3	Number of pulses to dial 3.	0x0003
U3B	PD4	Number of pulses to dial 4.	0x0004
U3C	PD5	Number of pulses to dial 5.	0x0005
U3D	PD6	Number of pulses to dial 6.	0x0006
U3E	PD7	Number of pulses to dial 7.	0x0007
U3F	PD8	Number of pulses to dial 8.	0x0008
U40	PD9	Number of pulses to dial 9.	0x0009
U42	PDBT	Pulse dial break time (ms units).	0x003D
U43	PDMT	Pulse dial make time (ms units).	0x0027
U45	PDIT	Pulse dial interdigit time (ms units).	0x0320
U46	DTPL	DTMF power level—16-bit format is 0x0(H)(L)0 where H is the (–)dBm level of the high-frequency DTMF tone and L is the (–)dBm level of the low-frequency DTMF tone. Note that twist may be specified here.	0x09B0
U47	DTNT	DTMF on time (ms units).	0x0064
U48	DTFT	DTMF off time (ms units).	0x0064
U49	RGFH	Ring frequency high—Maximum frequency ring to be considered a valid ring. RGFH = 2400/(maximum ring frequency).	0x0022
U4A	RGFD	Ring delta  $RGFD = 2400 \text{ Hz} \times \left[ \left( \frac{1}{\text{min ring freq (Hz)}} \right) - \left( \frac{1}{\text{max ring freq (Hz)}} \right) \right]$	0x007A
U4B	RGMN	Ring cadence minimum ON time in seconds multiplied by 2400.	0x0258
U4C	RGNX	Ring cadence maximum total time in seconds multiplied by 2400.	0x6720
U4D	MOD1	This is a bit-mapped register.	0x0000
U4E	PRDD	Pre-dial delay-time after ATD command that modem waits to dial (ms units). The Si2457/34/15/04 stays on-hook during this time.	0x0000

Table 16. U-Register Description (Continued)

Register	Name	Description	Default
U4F	FHT	Flash Hook Time. Time corresponding with “!” or “&” dial modifier that the Si2457/34/15/04 goes on-hook during a flash hook (ms units).	0x01F4
U50	LCDN	Loop current debounce on time (ms units).	0x015E
U51	LCDF	Loop current debounce off time (ms units).	0x00C8
U52	XMTL	Transmit level (1 dB units)—Sets the modem data pump transmitter level. Default level of 0 corresponds to $-9.85$ dBm. Transmit level = $-(9.85 + XMTL)$ dBm. Range = $-9.85$ to $-48$ .	0x0000
U53	MOD2	This is a bit-mapped register.	0x0000
U62	DAAC1	This is a bit-mapped register.	0x0804
U63	DAAC3	This is a bit-mapped register.	0x0003
U65	DAAC4	This is a bit-mapped register.	0x00E0
U66	DAAC5	This is a bit-mapped register.	0xXX40
U67	ITC1	This is a bit-mapped register.	0x0008
U68	ITC2	This is a bit-mapped register.	0x0000
U6A	ITC4	This is a bit-mapped register.	N/A
U6C	LVS	This is a bit-mapped register.	0xXX00
U6E	CK1	This is a bit-mapped register.	0xXF20
U6F	PTMR	This is a bit-mapped register.	0x00FF
U70	IO0	This is a bit-mapped register.	0x2700
U71	IO1	This is a bit-mapped register.	0x0000
U76	GEN1	This is a bit-mapped register.	0x3240
U77	GEN2	This is a bit-mapped register.	0x401E
U78	GEN3	This is a bit-mapped register.	0x0000
U79	GEN4	This is a bit-mapped register.	0x00XX
U7A	GENA	This is a bit-mapped register.	0x0000
U83	NOLN	No-Line threshold. If %V1 is set, NOLN sets the threshold for determination of line present vs. line not present.	0x0001
U84	LIUS	Line-in-use threshold. If %V1 is set, LIUS sets the threshold for determination of line in use vs. line not in use.	0x0007
U85	NLIU	Line-in-use/No line threshold. If %V2 is set, NLIU sets the threshold reference for the adaptive algorithm (see %V2).	0x0000
U86	V9AGG	V.90 rate adjustment for Japan (1333 BPS units).	0x0000



**Table 16. U-Register Description (Continued)**

Register	Name	Description	Default
U87	SAM	This is a bit-mapped register	0x0000
U9F	SASF	SAS frequency detection. See “AN93: Modem Designer’s Guide” for complete details.	0x0000
UA0	SC0	SAS cadence 0. Sets the duration of the first SAS tone (ms).	0x001E
UA1	SC1	SAS cadence 1. Sets the duration of the first SAS silence (ms).	0x0000
UA2	SC2	SAS cadence 2. Sets the duration of the second SAS tone (ms).	0x0000
UA3	SC3	SAS cadence 3. Sets the duration of the second SAS silence (ms).	0x0000
UA4	SC4	SAS cadence 4. Sets the duration of the third SAS tone (ms).	0x0000
UA5	SC5	SAS cadence 5. Sets the duration of the third SAS silence (ms).	0x0000
UA6	SC6	SAS cadence 6. Sets the duration of the fourth SAS tone (ms).	0x0000
UA7	SC7	SAS cadence 7. Sets the duration of the fourth SAS silence (ms).	0x0000
UA8	SC8	SAS cadence 8. Sets the duration of the fifth SAS tone (ms).	0x0000
UA9	SC9	SAS cadence 9. Sets the duration of the fifth SAS silence (ms).	0x0000
UAA	V29MODE	This is a bit mapped register.	0x0000

Table 17. Bit-Mapped U-Register Summary

Reg.	Name	Bit 15	Bit 14	Bit 13	Bit 12	Bit 11	Bit 10	Bit 9	Bit 8	Bit 7	Bit 6	Bit 5	Bit 4	Bit 3	Bit 2	Bit 1	Bit 0	
U4D	MOD1		TOCT		NHFP	NHFD	CLPD		FTP	SPDM		GT18	GT55	CTE				
U53	MOD2	REV																
U62	DAAC1								OHS2						FOH	DL		
U63	DAAC3	LCS[7:0]							ACT[3:0]									
U65	DAAC4		PWMG	PDN									PDL					
U66	DAAC5										FDT							
U67	ITC1			MINI[1:0]				ILIM		DCR	OHS			DCV[1:0]		RZ	RT	
U68	ITC2													BTE	ROV	BTD		
U6A	ITC4													OVL				
U6C	LVS	LVS[7:0]																
U6E	CK1			R1[4:0]														
U6F	PTME									PTMR[7:0]								
U70	IO0	HES		TES	CIDM	OCDM	PPDM	RIM	DCDM				CID	OCD	PPD	RI	DCD	
U71	IO1												COMP				PRT	
U76	GEN1	OHSR[7:0]							FACL	DCL[2:0]			ACL[4:0]					
U77	GEN2	IST[3:0]			HOI		AOC	OHT[8:0]										
U78	GEN3	IB[1:0]							IS[7:0]									
U79	GEN4										LVCS[4:0]							
U7A	GENA								DOP	ADD				V22HD	HDLC	FAST		
U7C	GENC											RIGPO					RIG-POEN	
U7D	GEND		NLM												ATZD	FDP		
U87	SAM							MINT	SERM	FSMS	XMTT							
UAA	V29MODE															V29ENA		



# Si2457/34/15/04

## 6.1. Bit-Mapped U-Register Detail (defaults in bold)

### U4D MOD1

Bit	D15	D14	D13	D12	D11	D10	D9	D8	D7	D6	D5	D4	D3	D2	D1	D0
<b>Name</b>		TOCT		NHFP	NHFD	CLPD		FTP	SPDM		GT18	GT55	CTE			
<b>Type</b>	R/W			R/W		R/W	R/W		R/W	R/W		R/W	R/W	R/W		

Reset settings = 0x0000

Bit	Name	Function
15	Reserved	Read returns zero.
14	TOCT	<b>Turn Off Calling Tone.</b> <b>0 = Disable.</b> 1 = Enable.
13	Reserved	Read returns zero.
12	NHFP	<b>No Hook Flash Pulse.</b> <b>0 = Disable.</b> 1 = Enable.
11	NHFD	<b>No Hook Flash Dial.</b> <b>0 = Disable.</b> 1 = Enable.
10	CLPD	<b>Check Loop Current Before Dialing.</b> <b>0 = Ignore.</b> 1 = Check.
9	Reserved	Read returns zero.
8	FTP	<b>Force Tone or Pulse.</b> <b>0 = Disable.</b> 1 = Enable.
7	SPDM	<b>Skip Pulse Dial Modifier.</b> <b>0 = No.</b> 1 = Yes.
6	Reserved	Read returns zero.
5	GT18	<b>1800 Hz Guard Tone Enable.</b> <b>0 = Disable.</b> 1 = Enable.
4	GT55	<b>550 Hz Guard Tone Enable.</b> <b>0 = Disable.</b> 1 = Enable.
3	CTE	<b>Calling Tone Enable.</b> <b>0 = Disable.</b> 1 = Enable.
2:0	Reserved	Read returns zero.



## U53 MOD2

Bit	D15	D14	D13	D12	D11	D10	D9	D8	D7	D6	D5	D4	D3	D2	D1	D0
<b>Name</b>	REV															
<b>Type</b>	R/W															

Reset settings = 0x0000

Bit	Name	Function
15	REV	<b>V.23 Reversing.</b> 0 = Disable. 1 = Enable.
14:0	Reserved	Read returns zero.

## U62 DAAC1

Bit	D15	D14	D13	D12	D11	D10	D9	D8	D7	D6	D5	D4	D3	D2	D1	D0
<b>Name</b>	0	0	0	0	1	0	0	OHS2	0	0	0	0	0	FOH	DL	0
<b>Type</b>	R/W												R/W	R/W		

Reset settings = 0x0804

Bit	Name	Function
15:12	Reserved	Must be set to 0.
11	Reserved	Must be set to 1.
10:9	Reserved	Must be set to 0.
8	OHS2	<b>On-Hook Speed 2.</b> This bit works in combination with the OHS bit (U67, bit 6) to set the on-hook speed. The on-hook speeds are measured from the time the OH bit is cleared until loop current equals zero. <b>OHS    OHS2Mean On-Hook Speed</b> 0        0 Less than 0.5 ms 0        1 3 ms $\pm$ 10% (meets ETSI standard) 1        X 26 ms $\pm$ 10% (meets Australia spark quenching spec)
7:3	Reserved	Must be set to 0.
2	FOH	<b>Fast Off-Hook.</b> 0 = Automatic Calibration Time set to 426 ms. 1 = Automatic Calibration Time set to 106 ms.
1	DL	<b>Isolation Digital Loopback (see the AT&amp;T commands).</b> 0 = Loopback occurs beyond the DAA interface, out to and including the analog hybrid circuit. 1 = Enables digital loopback mode across isolation barrier only. Clear after test is terminated.
0	Reserved	Must be set to 0.



# Si2457/34/15/04

## U63 DAAC3

Bit	D15	D14	D13	D12	D11	D10	D9	D8	D7	D6	D5	D4	D3	D2	D1	D0
Name	LCS[7:0]							ACT[3:0]								
Type	R/W															

Reset settings = 0x0003

Bit	Name	Function
15:8	LCS[7:0]	Off-Hook Loop Current (1.1 mA/bit).
7:4	ACT[3:0]	<b>AC Termination Select.</b> <b>ACT[3:0] AC Termination</b> <b>0000 Real 600 Ω</b> 0011 220 Ω + (820 Ω    120 nF) and 220 Ω + (820 Ω    115 nF) 0100 370 Ω + (620 Ω    310 nF) 1111 Global complex impedance
3:0	Reserved	Read returns 0x3.

## U65 DAAC4

Bit	D15	D14	D13	D12	D11	D10	D9	D8	D7	D6	D5	D4	D3	D2	D1	D0
Name		PWMG	PDN									PDL				
Type		R/W	R/W									R/W				

Reset settings = 0x00E0

Bit	Name	Function
15	Reserved	Read returns zero.
14	PWMG	<b>PWM Gain.</b> <b>0 = No gain.</b> 1 = 6 dB gain applied to AOUT.
13	PDN	<b>Powerdown.</b> Completely powerdown the Si2457/34/15/04 and Si3018. Once set to 1, the Si2457/34/15/04 must be reset to power on. <b>0 = Normal.</b> 1 = Powerdown.
12:8	Reserved	Read returns zero.
7:5	Reserved	Must not change in a read-modify-write.
4	PDL*	<b>Powerdown Line-Side Chip.</b> <b>0 = Normal operation.</b> 1 = Places the Si3018 in powerdown mode.
3:0	Reserved	Must not change in a read-modify-write.

\*Note: Typically used only for board-level debug.

## U66 DAAC5

Bit	D15	D14	D13	D12	D11	D10	D9	D8	D7	D6	D5	D4	D3	D2	D1	D0
Name										FDT						
Type	R															

Reset settings = 0xXX40

Bit	Name	Function
15:7	Reserved	Do not modify.
6	FDT*	<b>Frame Detect.</b> 0 = Indicates ISModem has not established frame lock. 1 = Indicates ISModem frame lock has been established.
5:0	Reserved	Read returns zero.
*Note: Typically used only for board-level debug.		



# Si2457/34/15/04

## U67 ITC1

Bit	D15	D14	D13	D12	D11	D10	D9	D8	D7	D6	D5	D4	D3	D2	D1	D0
Name			MINI[1:0]				ILIM		DCR	OHS			DCV[1:0]		RZ	RT
Type			R/W				R/W		R/W	R/W			R/W		R/W	R/W

Reset settings = 0x0008

Bit	Name	Function												
15:14	Reserved	Read returns zero.												
13:12	MINI[1:0]	<p><b>Minimum Operational Loop Current.</b> Adjusts the minimum loop current at which the DAA can operate. Increasing the minimum operational loop current can improve signal headroom at a lower TIP/RING voltage.</p> <table border="1"> <thead> <tr> <th>MINI[1:0]</th> <th>Min Loop Current</th> </tr> </thead> <tbody> <tr> <td>00</td> <td>10 mA</td> </tr> <tr> <td>01</td> <td>12 mA</td> </tr> <tr> <td>10</td> <td>14 mA</td> </tr> <tr> <td>11</td> <td>16 mA</td> </tr> </tbody> </table>	MINI[1:0]	Min Loop Current	00	10 mA	01	12 mA	10	14 mA	11	16 mA		
MINI[1:0]	Min Loop Current													
00	10 mA													
01	12 mA													
10	14 mA													
11	16 mA													
11:10	Reserved	Read returns zero												
9	ILIM	<p><b>Current Limiting Enable.</b> <b>0 = Current limiting mode disabled.</b> 1 = Current limiting mode enabled. This mode limits loop current to a maximum of 60 mA per the TBR21 standard.</p>												
8	Reserved	Read returns zero.												
7	DCR	<p><b>DC Impedance Selection.</b> <b>0 = Normal dc impedance. This mode should be used for all standard applications.</b> 1 = 800 <math>\Omega</math> dc termination.</p>												
6	OHS	<p><b>On-Hook Speed.</b> This bit works in combination with the OHS2 bit (U62, bit 8) to set the on-hook speed. The on-hook speeds are measured from the time the OH bit is cleared until loop current equals zero.</p> <table border="1"> <thead> <tr> <th>OHS</th> <th>OHS2</th> <th>Mean On-Hook Speed</th> </tr> </thead> <tbody> <tr> <td>0</td> <td>0</td> <td>Less than 0.5 ms</td> </tr> <tr> <td>0</td> <td>1</td> <td>3 ms <math>\pm</math>10% (meets ETSI standard)</td> </tr> <tr> <td>1</td> <td>X</td> <td>26 ms <math>\pm</math>10% (meets Australia spark quenching spec)</td> </tr> </tbody> </table>	OHS	OHS2	Mean On-Hook Speed	0	0	Less than 0.5 ms	0	1	3 ms $\pm$ 10% (meets ETSI standard)	1	X	26 ms $\pm$ 10% (meets Australia spark quenching spec)
OHS	OHS2	Mean On-Hook Speed												
0	0	Less than 0.5 ms												
0	1	3 ms $\pm$ 10% (meets ETSI standard)												
1	X	26 ms $\pm$ 10% (meets Australia spark quenching spec)												
5:4	Reserved	Read returns zero.												
3:2	DCV[1:0]	<p><b>TIP/RING Voltage Adjust.</b> These bits adjust the voltage on the DCT pin of the line-side device, which affects the TIP/RING voltage on the line. Low voltage countries should use a lower TIP/RING voltage. Raising the TIP/RING voltage can improve signal headroom.</p> <table border="1"> <thead> <tr> <th>DCV[1:0]</th> <th>DCT Pin Voltage</th> </tr> </thead> <tbody> <tr> <td>00</td> <td>3.1 V</td> </tr> <tr> <td>01</td> <td>3.2 V</td> </tr> <tr> <td><b>10</b></td> <td><b>3.35 V</b></td> </tr> <tr> <td>11</td> <td>3.5 V</td> </tr> </tbody> </table>	DCV[1:0]	DCT Pin Voltage	00	3.1 V	01	3.2 V	<b>10</b>	<b>3.35 V</b>	11	3.5 V		
DCV[1:0]	DCT Pin Voltage													
00	3.1 V													
01	3.2 V													
<b>10</b>	<b>3.35 V</b>													
11	3.5 V													

Bit	Name	Function
1	RZ	<b>Ringer Impedance.</b> <b>0 = Maximum (high) ringer impedance.</b> 1 = Synthesize ringer impedance. C15, R14, Z2, and Z3 must not be installed when setting this bit. See the “Ringer Impedance” section in “AN93: Modem Designer’s Guide”.
0	RT	<b>Ringer Threshold Select.</b> Used to satisfy country requirements on ring detection. Signals below the lower level does not generate a ring detection; signals above the upper level are guaranteed to generate a ring detection. <b>0 = 11 to 22 V<sub>rms</sub>.</b> <b>1 = 17 to 33 V<sub>rms</sub>.</b>

### U68 ITC2

Bit	D15	D14	D13	D12	D11	D10	D9	D8	D7	D6	D5	D4	D3	D2	D1	D0
Name														BTE	ROV	BTD
Type														R/W	R/W	R/W

Reset settings = 0x0000

Bit	Name	Function
15:3	Reserved	Do not modify.
2	BTE	<b>Billing Tone Protect Enable.</b> <b>0 = Disabled.</b> 1 = Enabled. When set, the DAA responds automatically to a collapse of the line-derived power supply during a billing tone event. When off-hook, if BTE = 1 and BTD goes high, the dc termination is released (800 Ω presented to line). If BTE and RIM (U70, bit 9) are set, an RI (U70, bit 1) interrupt also occurs when BTD goes high.
1	ROV	<b>Receive Overload.</b> The bit is set when the receive input (i.e., receive pin goes below ground) has an excessive input level. This bit is cleared by writing a 0 to this location. <b>0 = Normal receive input level.</b> 1 = Excessive receive input level.
0	BTD	<b>Billing Tone Detected.</b> This bit is set if a billing tone is detected. This bit is cleared by writing a 0 to this location. 0 = No billing tone. 1 = Billing tone detected.



# Si2457/34/15/04

## U6A ITC4

Bit	D15	D14	D13	D12	D11	D10	D9	D8	D7	D6	D5	D4	D3	D2	D1	D0
Name														OVL		
Type	R															

Reset settings = N/A

Bit	Name	Function
15:3	Reserved	Read returns zero.
2	OVL	<b>Overload Detected.</b> This bit has the same function as ROV, but clears itself after the overload has been removed. See the "Billing Tone Detection" section in "AN93: Modem Designer's Guide". This bit is not affected by the BTE bit.
1:0	Reserved	Do not modify.

## U6C LVS

Bit	D15	D14	D13	D12	D11	D10	D9	D8	D7	D6	D5	D4	D3	D2	D1	D0
Name	LVS[7:0]															
Type	R															

Reset settings = 0xXX40

Bit	Name	Function
15:8	LVS[7:0]	<b>Line Voltage Status.</b> Eight bit signed, twos complement number representing the tip-ring voltage. Each bit represents 1 V. Polarity of the voltage is represented by the MSB (sign bit). 0000_0000 = Measured voltage is < 3 V.
7:0	Reserved	Read returns zero.

## U6E CK1

Bit	D15	D14	D13	D12	D11	D10	D9	D8	D7	D6	D5	D4	D3	D2	D1	D0	
Name				R1[4:0]													
Type	R/W																

Reset settings = 0xFF20

Bit	Name	Function
15:13	Reserved	Do not modify.
12:8	R1[4:0]	<b>R1 CLKOUT Divider.</b> See "AN93: Modem Designer's Guide" for details.
7:0	Reserved	Read returns zero.

## U6F PTMR

Bit	D15	D14	D13	D12	D11	D10	D9	D8	D7	D6	D5	D4	D3	D2	D1	D0
Name									PTMR[7:0]							
Type	R/W															

Reset settings = 0x00FF

Bit	Name	Function
15:8	Reserved	Do not modify
7:0	PTMR[7:0]	<b>Parallel Port Receive FIFO Interrupt Timer.</b> See "AN93: Modem Designer's Guide" for details.



# Si2457/34/15/04

## U70 IO0

Bit	D15	D14	D13	D12	D11	D10	D9	D8	D7	D6	D5	D4	D3	D2	D1	D0
<b>Name</b>	HES		TES	CIDM	OCDM	PPDM	RIM	DCDM	0			CID	OCD	PPD	RI	DCD
<b>Type</b>	R/W		R/W	R/W	R/W	R/W	R/W	R/W				R/W	R/W	R/W	R/W	R/W

Reset settings = 0x2700

Bit	Name	Function
15	HES	<b>Hardware Escape Pin.</b> 0 = Disable. 1 = Enable.
14	Reserved	Read returns zero.
13	TES	<b>Enable “+++” Escape.</b> 0 = Disable. 1 = Enable.
12	CIDM	<b>Caller ID Mask.</b> 0 = Change in CID will not affect INT. 1 = A low to high transition in CID activates $\overline{\text{INT}}$ .
11	OCDM	<b>Overcurrent Detect Mask.</b> 0 = Change in OCD does not affect INT. (“X” result code is not generated in command mode.) 1 = A low to high transition in OCD will activate INT. (“X” result code is generated in command mode.)
10	PPDM	<b>Parallel Phone Detect Mask.</b> 0 = Change in PPD does not affect $\overline{\text{INT}}$ . 1 = A low to high transition in PPD will activate INT.
9	RIM	<b>Ring Indicator.</b> 0 = Change in RI does not affect $\overline{\text{INT}}$ . 1 = A low to high transition in RI activates INT.
8	DCDM	<b>Data Carrier Detect Mask.</b> 0 = Change in DCD does not affect $\overline{\text{INT}}$ . 1 = A high to low transition in DCD (U70, bit 0), which indicates loss of carrier, activates INT.
7	Reserved	Must be set to zero.
6:5	Reserved	Read returns zero.
4	CID	<b>Caller ID (sticky).</b> Caller ID preamble has been detected; data will soon follow. Clears on :I read.
3	OCD	<b>Overcurrent Detect (sticky).</b> Overcurrent condition has occurred. Clears on :I read.
2	PPD	<b>Parallel Phone Detect (sticky).</b> Parallel phone detected since last off-hook event. Clears on :I read.
1	RI	<b>Ring Indicator.</b> Active high bit when the Si2457/34/15/04 is on-hook, indicates ring event has occurred. Clears on :I read.
0	DCD	<b>Data Carrier Detect (status).</b> Active high bit indicates carrier detected (equivalent to inverse of $\overline{\text{DCD}}$ pin).



## U71 IO1

Bit	D15	D14	D13	D12	D11	D10	D9	D8	D7	D6	D5	D4	D3	D2	D1	D0
Name												COMP				PRT
Type												R/W				R/W

Reset settings = 0x0000

Bit	Name	Function
15:5	Reserved	Read returns zero.
4	COMP	<b>0 = Disables compression (PCM mode).</b> 1 = Enables linear compression.
3:1	Reserved	Read returns zero.
0	PRT	<b>0 = Disables PCM mode.</b> 1 = Enables PCM mode.

## U76 GEN1

Bit	D15	D14	D13	D12	D11	D10	D9	D8	D7	D6	D5	D4	D3	D2	D1	D0
Name	OHSR[6:0]						FACL	DCL[2:0]			ACL[4:0]					
Type	R/W							R/W			R/W					

Reset settings = 0x3240

Bit	Name	Function
15:9	OHSR[6:0]	<b>Off-Hook Sample Rate (40 ms units).</b> Sets the sample rate for the off-hook intrusion algorithms (1 second default).
8	FACL	<b>Force ACL.</b> <b>0 = While off-hook, ACL is automatically updated with LVCS.</b> 1 = While off-hook, ACL does not change from the value written to it while on-hook.
7:5	DCL[2:0]	<b>Differential Current Level (3 mA units).</b> Sets the differential level between ACL and LVCS that will trigger an off-hook PPD interrupt (default = 2).
4:0	ACL[4:0]	<b>Absolute Current Level (3 mA units).</b> ACL represents the value of LVCS current when the ISOmodem® is off-hook and all parallel phones are on-hook. If ACL = 0, it is ignored by the off-hook intrusion algorithm. The ISOmodem will also write ACL with the contents of LVCS before an intrusion and before going on-hook (default = 0).



# Si2457/34/15/04

## U77 GEN2

Bit	D15	D14	D13	D12	D11	D10	D9	D8	D7	D6	D5	D4	D3	D2	D1	D0
<b>Name</b>	IST[3:0]				HOI		AOC	OHT[8:0]								
<b>Type</b>	R/W				R/W		R/W		R/W							

Reset settings = 0x401E

Bit	Name	Function
15:12	IST[3:0]	<b>Intrusion Settling Time (250 ms units).</b> Delay between when the ISModem goes off-hook and the off-hook intrusion algorithm begins. Default is 1 s.
11	HOI	<b>Hang-Up On Intrusion.</b> <b>0 = ISModem will not automatically hang up when an off-hook PPD interrupt occurs.</b> 1 = ISModem automatically hangs up on a PPD interrupt. If %Vn commands are set, HOI also causes the "LINE IN USE" result code upon PPD interrupt.
10	Reserved	Read returns zero.
9	AOC	<b>Auto Overcurrent.</b> <b>0 = Disable.</b> 1 = Enable. <b>Note:</b> AOC may falsely detect an overcurrent condition in the presence of line reversals or other transients. Therefore, this feature should not be used in applications or locations (such as Japan) where line reversals are common or may be expected.
8:0	OHT[8:0]	<b>Off-Hook Time (1 ms units).</b> Time before LVCS is checked for overcurrent condition after going off-hook (30 ms default).

## U78 GEN3

Bit	D15	D14	D13	D12	D11	D10	D9	D8	D7	D6	D5	D4	D3	D2	D1	D0
Name	IB[1:0]											IS[7:0]				
Type	R/W										R/W					

Reset settings = 0x00XX

Bit	Name	Function
15:14	IB[1:0]	<p><b>Intrusion Blocking.</b> Defines the method used to block the off-hook intrusion algorithm from operation after dialing has begun.</p> <p><b>0 = No intrusion blocking.</b> 1 = Intrusion disabled from start of dial to end of dial. 2 = Intrusion disabled from start of dial to IS register time-out. 3 = Intrusion disabled from start of dial to connect (“CONNECT XXX”, “NO DIALTONE”, or “NO CARRIER”).</p>
13:8	Reserved	Read returns zero.
7:0	IS[7:0]	<p><b>Intrusion Suspend (500 ms units).</b> When IB = 2, this register sets the length of time from when dialing begins that the off-hook intrusion algorithm is blocked (suspended) (default = 00000000<sub>b</sub>).</p>



## U79 GEN4

Bit	D15	D14	D13	D12	D11	D10	D9	D8	D7	D6	D5	D4	D3	D2	D1	D0
Name													LVCS[4:0]			
Type	R															

Reset settings = 0x0000

Bit	Name	Function
15:5	Reserved	Read returns zero.
4:0	LVCS[4:0]	<p><b>Line Voltage Current Sense.</b> Represents either the line voltage, loop current, or on-hook line monitor.</p> <p><b>On-Hook Voltage Monitor (2.75 V/bit ±20%).</b> 00000 = No line connected. 00001 = Minimum line voltage (<math>V_{MIN} = 3.0\text{ V} \pm 0.5\text{ V}</math>). 11111 = Maximum line voltage (<math>87\text{ V} \pm 20\%</math>). The line voltage monitor full scale may be modified by changing R5 as follows: <math>V_{MAX} = V_{MIN} + 4.2 (10M + R5 + 1.6k)/(R5 + 1.6k)/5</math></p> <p><b>Off-Hook Loop Current Monitor (3 mA/bit).</b> 00000 = No loop current. 00001 = Minimum loop current. 11110 = Maximum loop current. 11111 = Loop current is excessive (overload). Overload &gt; 140 mA in all modes except TBR21 Overload &gt; 54 mA in TBR21 mode</p> <p>LVCS is backward compatible with Si2456/33/14 ISModems. The LVCS value is absolute and does not reflect loop polarity. See U6C (LVS)[15:8] for 1 V/bit resolution and signed twos complement output</p>

## U7A GENA

Bit	D15	D14	D13	D12	D11	D10	D9	D8	D7	D6	D5	D4	D3	D2	D1	D0
Name									DOP	ADD				V22HD	HDLC	FAST
Type									R/W	R/W				R/W	R/W	R/W

Reset settings = 0x0000

Bit	Name	Function
15:8	Reserved	Read returns to zero.
7	DOP	<b>Dial or Pulse.</b> <b>0 = Normal ATDTW operation</b> 1 = Use ATDTW for Pulse/Tone Dial Detection (see also ATDW command)
6	ADD	<b>Adaptive Dialing</b> 1 = Enable <b>0 = Disable</b> Attempt DTMF dial, then fall back to pulse dialing if unsuccessful. First digit is dialed as DTMF. If a dialtone is still present after two seconds, the Si2457/34/15/04 will redial the first digit and remaining digits as pulse. If a dialtone is not present after two seconds, the Si2457/34/15/04 will dial the remaining digits as DTMF.
5:3	Reserved	Read returns to zero.
2	V22HD	<b>V.22bis Synchronous Mode.*</b> <b>0 = Normal asynchronous mode.</b> 1 = Transparent HDLC mode.
1	HDLC	<b>Synchronous Mode.*</b> <b>0 = Normal asynchronous mode.</b> 1 = Transparent HDLC mode.
0	FAST	<b>Fast Connect.*</b> <b>0 = Normal modem handshake timing per ITU/Bellcore standards.</b> 1 = Fast connect modem handshake timing.
<b>*Note:</b> When V22HD, HDLC, or FAST bits are set, \N0 (wire mode) must be used.		



# Si2457/34/15/04

## U7C GENC

Bit	D15	D14	D13	D12	D11	D10	D9	D8	D7	D6	D5	D4	D3	D2	D1	D0
Name												RIGPO				RIGPOEN
Type	R											R/W				

Reset settings = 0x0000

Bit	Name	Function
15:5	Reserved	Reads returns to zero.
4	RIGPO	$\overline{RI}$ $\overline{RI}$ follows this bit when RIGPIOEN = 1 <sub>b</sub> .
3:1	Reserved	Reads returns to zero.
0	RIGPOEN	<b>0 = <math>\overline{RI}</math> indicates valid ring signal. (Normal ring-indicator mode)</b> 1 = $\overline{RI}$ can be used as a general purpose output and follows U7C[4] (RIGPO).

## U7D GEND

Bit	D15	D14	D13	D12	D11	D10	D9	D8	D7	D6	D5	D4	D3	D2	D1	D0
Name		NLM													ATZD	FDP
Type	R/W														R/W	R/W

Reset settings = 0x0000

Bit	Name	Function
15	Reserved	Reads returns to zero.
14	NLM	<b>0 = Enables “No Loop Current” detect.</b> 1 = Disables “No Loop Current” detect.
13:2	Reserved	Reads returns to zero.
1	ATZD	<b>ATZ Disable.</b> <b>0 = ATZ functions normally.</b> 1 = Disable ATZ command.
0	FDP	<b>FSK Data Processing.</b> <b>0 = FSK data processing stops when carrier is lost.</b> 1 = FSK data processing continued for 2 bytes after carrier is lost.

## U87 SAM

Bit	D15	D14	D13	D12	D11	D10	D9	D8	D7	D6	D5	D4	D3	D2	D1	D0
Name						MINT	SERM	FSMS	XMTT[7:0]							
Type				R/W			R/W	R/W	R/W							

Reset settings = 0x0000

Bit	Name	Function
15:11	Reserved	Reads returns to zero.
10	MINT	<b>Minimal Transparency</b> <b>0 = Generates two-byte &lt;EM&gt; transparency sequences.</b> This option will use codes <EM><T5> through <EM><T20>, if possible, for received data containing two back-to-back bytes requiring transparency. <b>1 = Generates one-byte &lt;EM&gt; transparency sequences.</b> This option will only use codes <EM><T1> through <EM><T4> for received data.
9	SERM	<b>Special Error Reporting Mode</b> <b>0 = Ignore unrecognized in-band commands.</b> <b>1 = Generate &lt;EM&gt;&lt;0x45&gt; ("E" for error) in response to any unrecognized in-band commands.</b>
8	FSMS	<b>Framed Sub-Mode Startup</b> <b>0 = Upon successful connection, enter Transport Sub-Mode.</b> An <EM><FLAG> is required to enter Framed Sub-Mode. <b>1 = Upon successful connection, immediately enter Framed Sub-Mode.</b> The first received <EM><err> from a successful hunt is transformed into an <EM><flag>.
7:0	XMTT[7:0]	<b>Transmitter Threshold</b> This value represents the number of bytes before a transmission is started. The following values are special: 0     The same as ten. Upon receipt of ten bytes, data is transferred. The DTE must supply a closing flag within the required time or an underrun will occur. 255   The same as infinity, e.g. never start a packet until the closing flag is received.

## UAA V.29 Mode

Bit	D15	D14	D13	D12	D11	D10	D9	D8	D7	D6	D5	D4	D3	D2	D1	D0
Name															V29ENA	
Type	R/W															

Reset settings = 0x0000

Bit	Name	Function
15:2	Reserved	Reads returns to zero.
1	V29ENA	<b>0 = Disables V.29.</b> <b>1 = Enables V.29.</b>
0	Reserved	Read returns zero.



## 7. Parallel Interface Registers

---

### Parallel Interface 0 (0x00)

---

Bit	D7	D6	D5	D4	D3	D2	D1	D0
Name	TX/RX[7:0]							
Type	R/W							

Reset settings = 0x00

Bit	Name	Function
7:0	TX/RX[7:0]	<b>Parallel Interface Transmit/Receive.</b> This register functions similarly to the serial port TX pin on writes to the parallel port, and similarly to the serial port RX pin on reads from the parallel port.



## Parallel Interface 1 (0x01)

Bit	D7	D6	D5	D4	D3	D2	D1	D0
Name	RXF	TXE	REM	INTM	INT	ESC	$\overline{\text{RTS}}$	$\overline{\text{CTS}}$
Type	R	R	R	R/W	R	R/W	R/W	R

Reset settings = 0110\_0011

Bit	Name	Function
7	RXF	<p><b>Receive FIFO Almost Full (status).</b></p> <p>0 = Receive FIFO (12 deep) contains three or more empty locations (<math>\text{RXF} \leq 9</math>). The host can clear the RXF interrupt without emptying the RX FIFO by writing a 0 to the RXF bit. This will disable the RXF interrupt until the host has emptied the FIFO.</p> <p>1 = Receive FIFO contains two or less empty locations (<math>\text{RXF} \geq 10</math>).</p>
6	TXE	<p><b>Transmit FIFO Almost Empty (status).</b></p> <p>0 = Transmit FIFO (14 deep) contains three or more characters (<math>\text{TXF} \geq 3</math>).</p> <p>1 = Transmit FIFO contains two or less characters (<math>\text{TXF} \leq 2</math>).</p> <p><b>Note:</b> TXE interrupt will not trigger if the CTS bit is inactive. Therefore, the host does not need to poll CTS while waiting for transmit FIFO to empty. TXE can be cleared by writing it to 0.</p>
5	REM	<p><b>Receive FIFO Empty.</b></p> <p>0 = Receive FIFO has valid data.</p> <p>1 = Receive FIFO empty.</p> <p><b>Note:</b> If the interim timer (see PTMR - U6F, bits 7:0) set by PTMR expires, it will cause an interrupt. This interrupt will not set RXF, TXE, or INT. The interrupt handler on the host should then verify that <math>\text{REM} = 0</math> and begin to empty the receive FIFO (Parallel Interface 0 register) until <math>\text{REM} = 1</math>.</p>
4	INTM	<p><b>Interrupt Mask.</b></p> <p>0 = In parallel mode, the <math>\overline{\text{INT}}</math> pin is triggered by a rising edge on RXF or TXE only (default).</p> <p>1 = In parallel mode, the <math>\overline{\text{INT}}</math> pin is triggered by a rising edge on RXF, TXE, or INT.</p>
3	INT	<p><b>Interrupt.</b></p> <p>0 = No interrupt has occurred.</p> <p>1 = Indicates that an interrupt (CID, OCD, PPD, RI, or DCD from U70) has occurred. This bit is cleared via the AT:I command.</p>
2	ESC	<p><b>Escape.</b></p> <p>Operation of this bit in parallel mode is functionally equivalent to the ESC pin in serial mode.</p>
1	$\overline{\text{RTS}}$	<p><b>Request-to-Send.</b></p> <p>Operation of this bit in parallel mode is functionally equivalent to the <math>\overline{\text{RTS}}</math> pin in serial mode. Use of the <math>\overline{\text{CTS}}</math> and <math>\overline{\text{RTS}}</math> bits (as opposed to the TXE and RXF bits) allows the flow control between the host and the ISModem® to operate 1 byte at a time, rather than in blocks.</p>
0	$\overline{\text{CTS}}$	<p><b>Clear-to-Send.</b></p> <p>Operation of this bit in parallel mode is functionally equivalent to the <math>\overline{\text{CTS}}</math> pin in serial mode. Use of the <math>\overline{\text{CTS}}</math> and <math>\overline{\text{RTS}}</math> bits (as opposed to the TXE and RXF bits) allows the flow control between the host and the ISModem to operate 1 byte at a time, rather than in blocks.</p>



# Si2457/34/15/04

## 8. Pin Descriptions: Si2457/34/15/04 (16-Pin Option)

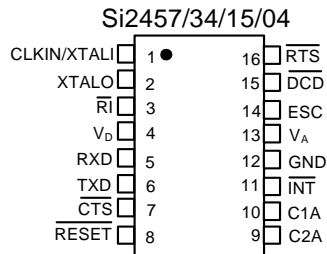

Pin #	Pin Name	Description
1	CLKIN/XTALI	<b>XTALI—Crystal Oscillator Pin.</b> Provides support for parallel resonant AT cut crystals. A 4.9152 MHz crystal or a 4.9152 or 27 MHz clock on XTALI is required.
2	XTALO	<b>XTALO—Crystal Oscillator Pin.</b> Serves as the output of the crystal amplifier.
3	$\overline{RI}$	<b>Ring Indicator.</b> The RI on (active low) indicates the presence of an ON segment of a ring signal on the telephone line.
4	$V_D$	<b>Supply Voltage.</b> Provides the 3.3 V supply voltage to the Si2457/34/15/04.
5	RXD	<b>Receive Data.</b> Data output to DTE RXD pin.
6	TXD	<b>Transmit Data.</b> Data input from DTE TXD pin.
7	$\overline{CTS}$	<b>Clear to Send.</b> Signals that the Si2457/34/15/04 is ready to receive more digital data on the TXD pin.
8	$\overline{RESET}$	<b>Reset Input.</b> An active low input that is used to reset all control registers to a defined, initialized state.
9	C2A	<b>Isolation Capacitor 2A.</b> Connects to one side of the isolation capacitor C2.
10	C1A	<b>Isolation Capacitor 1A.</b> Connects to one side of the isolation capacitor C1.
11	$\overline{INT}$	<b>Interrupt Output.</b> Active low interrupt output.
12	GND	<b>Ground.</b> Connects to the system digital ground.
13	$V_A$	<b>Regulator Voltage Reference.</b> Connects to an external capacitor and serves as the reference for the internal voltage regulator.
14	ESC	<b>Escape.</b> A positive edge on this pin causes the modem to go from online (connected) mode to the offline (command) mode.
15	$\overline{DCD}$	<b>Carrier Detect.</b> Active low carrier detect.
16	$\overline{RTS}$	<b>Request to Send.</b> Active low request to send input used for flow control.

## 9. Pin Descriptions: Si2457/34/15/04 (24-Pin Option)

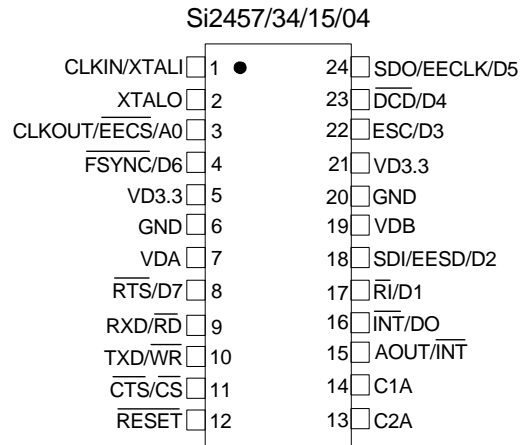

Pin #	Pin Name	Description
1	CLKIN/XTALI	<b>Clock Input/Crystal Oscillator Pin.</b> Provides support for parallel resonant AT cut crystals. A 4.9152 MHz crystal or a 4.9152 or 27 MHz clock on XTALI is required.
2	XTALO	<b>Crystal Oscillator Pin.</b> Serves as the output of the crystal amplifier.
3	CLKOUT/ $\overline{\text{EECS}}/\text{A0}$	<b>Clock Output/EEPROM Chip Select/Address Bit 0.</b> Clock output in serial mode. Active low read/write enable for SPI EEPROM in serial mode when pin 4 is pulled low during powerup. Address Enable in parallel mode.
4	$\overline{\text{FSYNC}}/\text{D6}$	<b>Frame Sync/Data Bit.</b> Frame Sync output to codec in serial mode. Bidirectional parallel bus data bit 6 in parallel mode.
5, 21	VD3.3	<b>Digital Supply Voltage.</b> Provides the 3.3 V supply voltage to the Si2457/34/15/04.
6, 20	GND	<b>Ground.</b> Connects to the system digital ground.
7, 19	VDA, VDB	<b>Regulator Voltage Reference.</b> Connects to an external capacitor and serves as the reference for the internal voltage regulator.
8	$\overline{\text{RTS}}/\text{D7}$	<b>Request to Send/Data Bit.</b> Active low request to send input used for flow control in serial mode. Bidirectional parallel bus data bit 7 in parallel mode.
9	RXD/ $\overline{\text{RD}}$	<b>Receive Data/Read Enable.</b> Data output to DTE RXD pin in serial mode. Active low read enable pin in parallel mode.



# Si2457/34/15/04

Pin #	Pin Name	Description
10	TXD/ $\overline{\text{WR}}$	<b>Transmit Data/Write Enable.</b> Data input from DTE TXD pin in serial mode. Active low write enable pin in parallel mode.
11	$\overline{\text{CTS/CS}}$	<b>Clear to Send/Chip Select.</b> Signals that the Si2457/34/15/04 is ready to receive more digital data on the TXD pin in data mode. Active low chip select in parallel mode.
12	$\overline{\text{RESET}}$	<b>Reset Input.</b> An active low input that is used to reset all control registers to a defined initialized state.
13	C2A	<b>Isolation Capacitor 2A.</b> Connects to one side of the isolation capacitor, C2.
14	C1A	<b>Isolation Capacitor 1A.</b> Connects to one side of the isolation capacitor, C1.
15	AOUT/ $\overline{\text{INT}}$	<b>Analog Output/Interrupt Output.</b> Analog output in serial mode. Active low interrupt output in parallel mode.
16	$\overline{\text{INT/D0}}$	<b>Interrupt Output/Data Bit.</b> Active low interrupt output in serial mode. Bidirectional parallel bus data bit 0 in parallel mode.
17	$\overline{\text{RI/D1}}$	<b>Ring Indicator/Data Bit.</b> The $\overline{\text{RI}}$ on (active low) indicates the presence of an ON segment of a ring signal on the telephone line. Bidirectional parallel bus data bit 1 in parallel mode.
18	SDI/EEESD/D2	<b>Serial Data In/EEPROM Serial Data Input/Output/Data Bit.</b> Serial Data In (to codec) output in serial mode. Bidirectional Input/Output to SPI EEPROM in serial mode when pin 4 is pulled low during power up. Bidirectional parallel bus data bit 2 in parallel mode.
22	ESC/D3	<b>Escape/Data Bit.</b> Hardware escape in serial mode. Bidirectional parallel bus data bit 3 in parallel mode.
23	$\overline{\text{DCD/D4}}$	<b>Carrier Detect/Data Bit.</b> Active low carrier detect in serial mode. Bidirectional parallel bus data bit 4 in parallel mode.
24	SDO/EECLK/D5	<b>Serial Data Out/EEPROM Clock/Data Bit 5.</b> Serial Data Out (from codec) input in serial mode. Clock output for SPI EEPROM in serial mode when pin 4 is pulled low during power up. Bidirectional parallel bus data bit 5 in parallel mode.

## 10. Pin Descriptions: Si3018/10

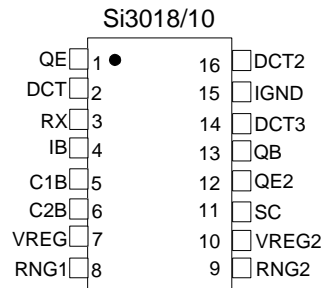

Table 18. Si3018 Pin Descriptions

Pin #	Pin Name	Description
1	QE	<b>Transistor Emitter.</b> Connects to the emitter of Q3.
2	DCT	<b>DC Termination.</b> Provides dc termination to the telephone network.
3	RX	<b>Receive Input.</b> Serves as the receive side input from the telephone network.
4	IB	<b>Internal Bias.</b> Provides a bias voltage to the device.
5	C1B	<b>Isolation Capacitor 1B.</b> Connects to one side of isolation capacitor C1 and communicates with the system side.
6	C2B	<b>Isolation Capacitor 2B.</b> Connects to one side of isolation capacitor C2 and communicates with the system side.
7	VREG	<b>Voltage Regulator.</b> Connects to an external capacitor to provide bypassing for an internal power supply.
8	RNG1	<b>Ring 1.</b> Connects through a resistor to the RING lead of the telephone line. Provides the ring and caller ID signals to the Si2457/34/15/04.
9	RNG2	<b>Ring 2.</b> Connects through a resistor to the TIP lead of the telephone line. Provides the ring and caller ID signals to the Si2457/34/15/04.
10	VREG2	<b>Voltage Regulator 2.</b> Connects to an external capacitor to provide bypassing for an internal power supply.
11	SC	<b>SC Connection.</b> Enables external transistor network. Should be tied through a 0 $\Omega$ resistor to I <sub>GND</sub> .
12	QE2	<b>Transistor Emitter 2.</b> Connects to the emitter of Q4.
13	QB	<b>Transistor Base.</b> Connects to the base of transistor Q4.
14	DCT3	<b>DC Termination 3.</b> Provides the dc termination to the telephone network.
15	IGND	<b>Isolated Ground.</b> Connects to ground on the line-side interface.
16	DCT2	<b>DC Termination 2.</b> Provides dc termination to the telephone network.



## 11. Ordering Guide

Chipset	Max Speed	System-Side Package	System-Side*	Line-Side*	Temp Range
Si2457	56 kbps	24-pin TSSOP	Si2457-C-FT	Si3018-F-FS	0 to 70 °C
Si2457	56 kbps	16-pin SOIC	Si2457-C-FS	Si3018-F-FS	0 to 70 °C
Si2434	33.6 kbps	24-pin TSSOP	Si2434-C-FT	Si3018-F-FS	0 to 70 °C
Si2434	33.6 kbps	16-pin SOIC	Si2434-C-FS	Si3018-F-FS	0 to 70 °C
Si2415	14.4 kbps	24-pin TSSOP	Si2415-C-FT	Si3018-F-FS	0 to 70 °C
Si2415	14.4 kbps	16-pin SOIC	Si2415-C-FS	Si3018-F-FS	0 to 70 °C
Si2404	2400 bps	24-pin TSSOP	Si2404-C-FT	Si3010-F-FS	0 to 70 °C
Si2404	2400 bps	16-pin SOIC	Si2404-C-FS	Si3010-F-FS	0 to 70 °C
Si2457	56 kbps	24-pin TSSOP	Si2457-C-GT	Si3018-F-GS	-40 to +85 °C
Si2434	33.6 kbps	24-pin TSSOP	Si2434-C-GT	Si3018-F-GS	-40 to +85 °C
Si2415	14.4 kbps	24-pin TSSOP	Si2415-C-GT	Si3018-F-GS	-40 to +85 °C
Si2404	2400 bps	24-pin TSSOP	Si2404-C-GT	Si3018-F-GS	-40 to +85 °C

**\*Note:** Add an "R" at the end of the device to denote tape and reel option; 2500 quantity per reel.

## 12. Package Outline: 24-Pin TSSOP

Figure 9 illustrates the package details for the Si2457/34/15/04 24-pin packaging option. Table 19 lists the values for the dimensions shown in the illustration.

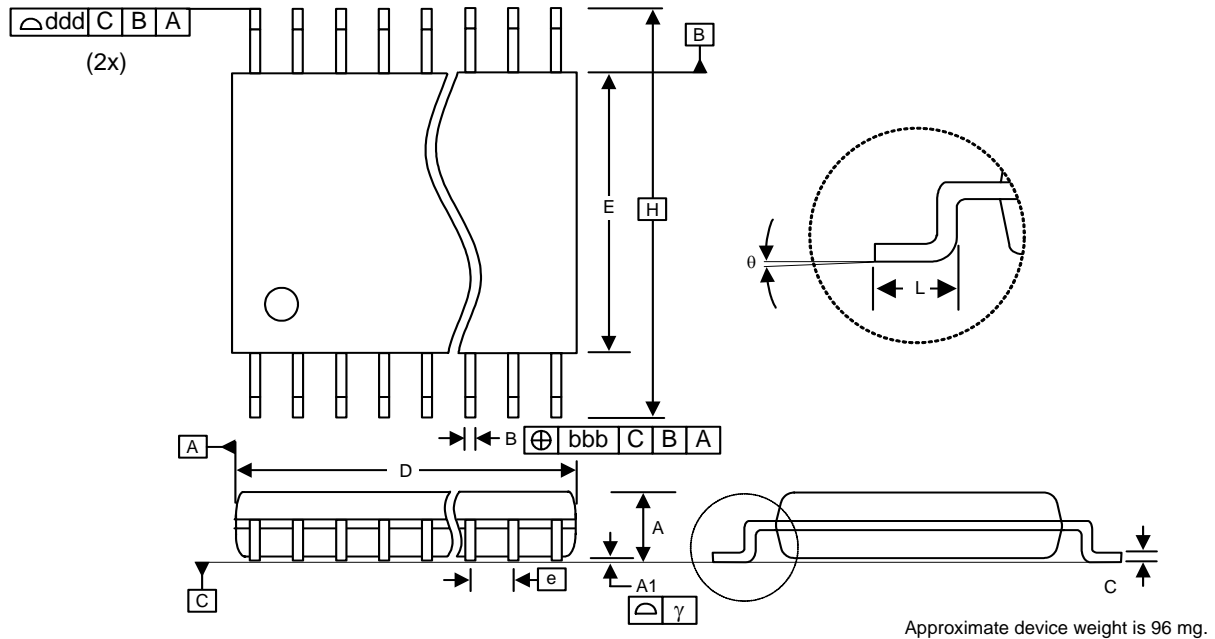

Figure 9. 24-Pin Thin Shrink Small Outline Package (TSSOP)

Table 19. Package Diagram Dimensions

Symbol	Millimeters	
	Min	Max
A	—	1.20
A1	0.05	0.15
B	0.19	0.30
C	0.09	0.20
D	7.70	7.90
E	4.30	4.50
e	0.65 BSC	
H	6.40 BSC	
L	0.45	0.75
$\theta$	0°	8°
$\gamma$	0.10	
bbb	0.10	
ddd	0.20	



## 13. Package Outline: 16-Pin SOIC

Figure 10 illustrates the package details for the Si3018/10 and the Si2457/34/15/04 16-pin packaging option. Table 20 lists the values for the dimensions shown in the illustration.

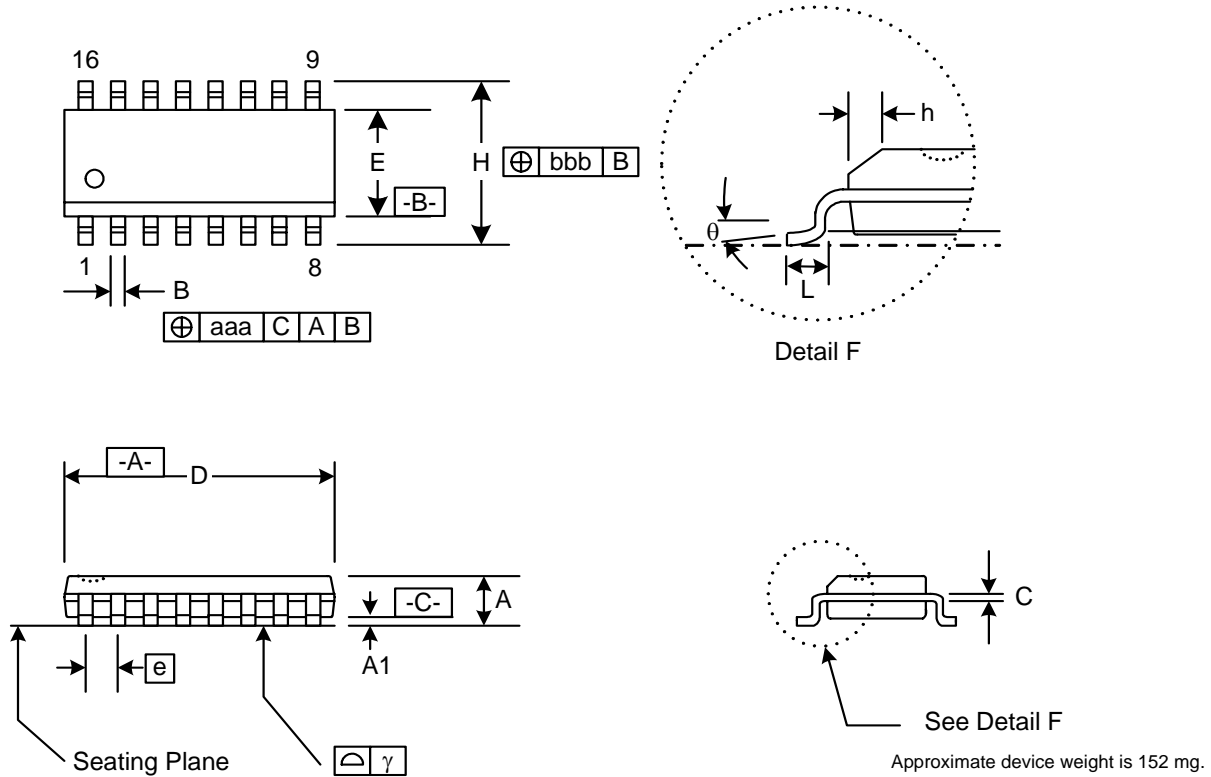

**Figure 10. 16-pin Small Outline Integrated Circuit (SOIC) Package**

**Table 20. Package Diagram Dimensions**

Symbol	Millimeters	
	Min	Max
A	1.35	1.75
A1	.10	.25
B	.33	.51
C	.19	.25
D	9.80	10.00
E	3.80	4.00
e	1.27 BSC	
H	5.80	6.20
h	.25	.50
L	.40	1.27
$\gamma$	0.10	
$\theta$	0°	8°
aaa	0.25	
bbb	0.25	



## DOCUMENT CHANGE LIST

### Revision 0.91 to Revision 1.0

- Added Figure 5 typical schematic with 16-pin system-side option.
- Updated Table 3 to include 16-pin system-side parameters.
- Updated default register setting in Table 16.
- Added Si2404 information.
- Added 16-pin system-side option.
- Updated "4. Functional Description" on page 16.
- Added "8. Pin Descriptions: Si2457/34/15/04 (16-Pin Option)" on page 66.
- Updated "11. Ordering Guide" on page 70 to reflect part revision.

### Revision 1.0 to Revision 1.1

- Added industrial temperature range devices.



## CONTACT INFORMATION

### Silicon Laboratories Inc.

4635 Boston Lane  
Austin, TX 78735  
Tel: 1+(512) 416-8500  
Fax: 1+(512) 416-9669  
Toll Free: 1+(877) 444-3032  
Email: ISOinfo@silabs.com  
Internet: www.silabs.com

The information in this document is believed to be accurate in all respects at the time of publication but is subject to change without notice. Silicon Laboratories assumes no responsibility for errors and omissions, and disclaims responsibility for any consequences resulting from the use of information included herein. Additionally, Silicon Laboratories assumes no responsibility for the functioning of undescribed features or parameters. Silicon Laboratories reserves the right to make changes without further notice. Silicon Laboratories makes no warranty, representation or guarantee regarding the suitability of its products for any particular purpose, nor does Silicon Laboratories assume any liability arising out of the application or use of any product or circuit, and specifically disclaims any and all liability, including without limitation consequential or incidental damages. Silicon Laboratories products are not designed, intended, or authorized for use in applications intended to support or sustain life, or for any other application in which the failure of the Silicon Laboratories product could create a situation where personal injury or death may occur. Should Buyer purchase or use Silicon Laboratories products for any such unintended or unauthorized application, Buyer shall indemnify and hold Silicon Laboratories harmless against all claims and damages.

Silicon Laboratories, Silicon Labs, and ISModem are registered trademarks of Silicon Laboratories Inc.  
Other products or brandnames mentioned herein are trademarks or registered trademarks of their respective holders.