

HIGH SPEED FAMILY OF ULTRA SMALL MODEMS

| | | |
|---------------------------|----------|------------------------------------|
| CH2056A /-B / ET-B | – | V.92 / 57,600bps / TBR21 |
| CH1799A /-B / ET-B | – | V.34bis / 33,600bps / TBR21 |
| CH1794A /-B / ET-B | – | V.32bis / 14,400bps / TBR21 |

FEATURES

- Supports V.92, V.90, V.34bis, V.34, V.32bis, V.23, V.32, V.22bis, V.22A/B, V.23, V.21, Bell 212A and 103.
- CH2056A supports V.80 Synchronous operation.
- Error correcting: V.42 LAPM, MNP 2-4 and MNP10. MNP10 Data through put enhancement for cellular operation.
- Data Compression: V.42bis, V.44, and MNP 5
- DTE serial interface with speeds up to 230.4kbps (CH2056A), 115.2 (CH1799A) or 57.6kbps (CH1794A).
- RoHS Compliant versions available.
- Low Power 3.3V operation: 170mW (nominal).
- 5V operation: 300mW (nominal).
- Automatic baud rate adaptability utilizing speed sensing, flow control and data buffers.
- DTMF Encoding and Decoding.
- Send & Receive FAX class 1, Group 3 supported.
- Serial V.24 interface: 5V tolerant.
- NVRAM directory and stored profiles.
- AT Command structure, with extensions.
- Built-in DAA with 1500 VAC RMS isolation 2122V peak surge protection.
- UL 60950 and CSA C22.2 950 Recognized (E251266) (pending).
- FCC Part 68 approved (pending):
US:B46MM07BCHXXXAYY.
- Industry Canada CS-03 Part I Registered (pending):
IC:176A-CHXXXAY.
- PCM upstream (V.92 only).
- Modem-on-Hold (V.92 only).
- Quick Connect (V.92 only).
- Size: 1.01" x 1.27" x 0.52" (nominal).
- Pin compatible with low speed CH1786A.
- Fast Connect (V.22).
- Caller ID (optional).
- Zero Power (optional).
- Off-Hook Indication (optional).
- Leased Line version available.
- TBR21 Compliant version available.

INTRODUCTION

The CH2056A, CH1799A and CH1794A (HS Modem Family) are industrial grade high-speed modem modules. Each HS Modem product supports a range of modem standards and speeds from 300bps to 14,400bps, 28,800bps, 33,600bps or 57,600bps. By using built in compression algorithms the operation speed can be expanded to the maximum DTE rate of 57.6kbps for the CH1794A, 115.2kbps for the CH1799A and 230.4kbps for the CH2056A. A choice of error correcting schemes is available including MNP 10 for cellular telephone applications. The HS Modem family supports Send and Receive FAX. The CH179XA-L/CH2056A-L and CH179XAR-L/CH2056AR-L operates exclusively on non-voltage bearing leased line.

The HS Modem family is pin compatible with Cermetek's low cost CH1786A V.22bis, 2400bps modem family. Each module in the HS Modem family is a self-contained modem and is FCC Part 68 approved (pending) and Industry Canada approved (pending). Additionally, the CH179XA/CH2056A-B/ET-B and the CH1799AR/CH2056AR-B/ET-B products meet the European TBR21 requirements.

These ultra small modules are designed for PCB through-hole mounting and are 1.01" x 1.27" x 0.52" (nominal) in size. The HS Modem family requires only two external interfaces: a ITU-T V.24 serial interface for direct access to a UART, and a Tip and Ring RJ-11C Jack for the PSTN line connection. The HS Modem can be controlled with industry standard AT commands and is compatible with available industry communication software.

DESCRIPTION OF FUNCTIONAL BLOCKS AND DISCUSSION OF BASIC OPERATIONS

Figure 1 contains a functional block drawing of the HS Modem family of products. Each HS Modem product consists of a serial interface buffer, modulator/demodulator, modem controller with error correction and data compression, non-volatile RAM and a DAA.

Serial Host Interface Buffer. The HS Modem utilizes a serial V.24 EIA 232-E 5V interface to control the modem. The HS Modem products can communicate over the serial interface with the Data Terminal Equipment (DTE) at a fixed speed regardless of the carrier line modulation speed (DCE) of the PSTN modem connection. This eliminates the need to have

the DTE step up or step down in speed based on the in-coming or out-going PSTN communication data rate. Hence, the DTE can train the CH2056A, to say 56kbps, and talk to a slower in-coming data connection at say, 2400bps without changing host speed. Conversely, the host DTE trained at 14.4kbps can also communicate with the modems at higher speeds, say 28.8kbps. This is accomplished by invoking internal automatic data flow control. The HS Modem family has a resident buffer to allow for this auto baud operation.

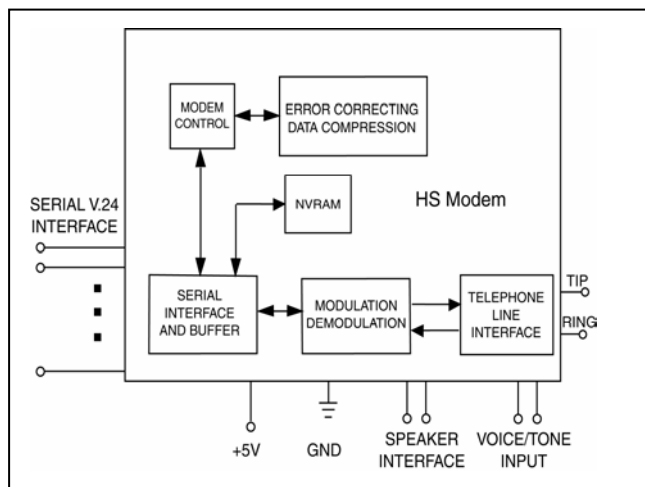

Figure 1. Functional Block Diagram of HS Modem Family.

Non-Volatile RAM (NVRAM). NVRAM can store user-customized configurations. The **AT&Wn** command will store the active modem configuration in one of two NVRAM locations as selected by an n of 0 or 1. The **AT&Yn** command selects one of the stored modem configurations to be automatically recalled and made active upon reset or power up. The **ATZn** command immediately recalls and activates a stored configuration. See Table 6 for storable S-Registers and Commands.

The NVRAM can save up to four telephone numbers, with up to 31 digits or modifiers in each telephone number. The **AT&Zn=s** command will store s, the telephone number dial string. The **ATDS=n** command will cause the modem to dial one of the four stored telephone numbers. The NVRAM storage location for the four telephone numbers is selected by an n of 0, 1, 2, or 3.

Telephone Line Interface or DAA. High performance modems are extremely sensitive to DAA (Data Access Arrangement) performance. The difference between a good modem and a fair one is in the DAA performance. The HS Modem family includes a unique low distortion DAA designed for optimal performance over all PSTN line conditions thereby achieving the most reliable and best performance PSTN connections.

The HS Modem family is designed to meet North American telephone standards as set by the FCC Part 68 (USA) and CSA CS-03 Part I (Canada). Among the more critical parameters, the PSTN line interface is designed to meet 1500 VAC RMS isolation and provide 2122V peak surge protection. Consequently, the HS Modem family of products satisfies U.S. and Canadian requirements, and will meet other international approval agency requirements that specify these levels of isolation.

Pins 1 and 2 function as both input and output connections to the PSTN. To maximize field reliability in hostile environments, for Canadian approval, for UL compliance, and also optionally for FCC Part 15 compliance, these two pins must be routed through an external network such as that briefly described in Figure 6A and described in more detail in Cermetek Application Note # 126.

Each HS Modem product comes with FCC Part 68 approval and is shipped from the factory with an FCC Label indicating registration number and ringer equivalent. This label should be prominently displayed on the end product. Canadian approval for CH1799A is listed on page 1. Canadian approvals for other products in Cermetek’s High Speed Modem Family are available upon request. With the exception of the U.S. and Canada, most countries require submission of the final product or system containing the HS Modem to the appropriate governing regulatory agency for approval. Typically this is accomplished by submitting the final end product to an independent test house or consultant for evaluation. The test house/consultant then forwards the test results and applicable documents to the regulatory agency. Contact Cermetek for a list of suggested consultants.

Modulation/Demodulation/Error Correcting and Data Compression. These functions are provided by an industry standard modem chip set which has been adapted for use with the HS Modem family. The Modulation/Demodulation scheme supports line equalization, forward error correction and the industry modem standards listed below.

| SUPPORTED MODULATION STANDARDS | |
|--------------------------------|---------------|
| Bell 103 | ITU-T V.22 |
| Bell212A | ITU-T V.22bis |
| | ITU-T V.32 |
| | ITU-T V.32bis |
| | ITU-T V.34 |
| | ITU-T V.34bis |
| | ITU-T V.90 |
| | ITU-T V.92 |

Error Correction. Error correction is enabled via the **Vn** command. Enabling error correction overrides **&Qn** and sets S36 and S48 values. Refer to Cermetek, "AT Commands and S-Registers", for a more detailed discussion.

The HS Modem supports V.42 LAPM, MNP 2-4, MNP 10 error correcting protocols. The CH1794A uses MNP5 data compression techniques and the CH1799A/CH2056A uses V.42bis and V.44 data compression, allowing data transmission rates of up to a maximum of 57.6kbps/115.2kbps/230.4kbps, respectively. These high DTE data rates are supported by the HS Modem serial interface via its auto baud capability. Note that the maximum speed attained is limited by the maximum speed available from the DTE.

IMPORTANT NOTE

The V.92 standard prescribes 56kbps downlink and 48.8kbps uplink. Consequently, two V.92 modems connected back-to-back will transmit at 48.8kbps (maximum).

Ring Indicator (RI). The RI pin follows the frequency of the ring signal and toggles low when the modem detects an incoming call. The ring signal is typically 20 to 30 Hz and is on for 2 seconds and off for 4 seconds. Although not TTL compliant, the RI pin can, nonetheless, be utilized to activate external circuitry including the external RST pin.

Off-Hook Indicator (OHI). The "H" version of the HS Modem provides an active high signal on the OHI pin (Pin # 18) indicating when the HS Modem goes off-hook. The circuit in Figure 2 can be used to drive an external LED. Note that the OHI output active (or high) is 2.75-3.25 volts.

+MS Command. The user may override the automatic data rate function of the HS modems. This is accomplished by executing the **+MS** command. This command allows the user to specify the desired data modulation protocol. Further, the **+MS** command may be used to force a desired data rate and/or restrict the allowed data rate. The supported modulation schemes are listed above.

The following examples establish the V.22bis modulation scheme:

Enter: **AT+MS=V22B**
Result: **OK**

This is identical to the following explicit **+MS** command:

Enter: **AT+MS=V22B,0,300,1200,300,1200**
Result: **OK**

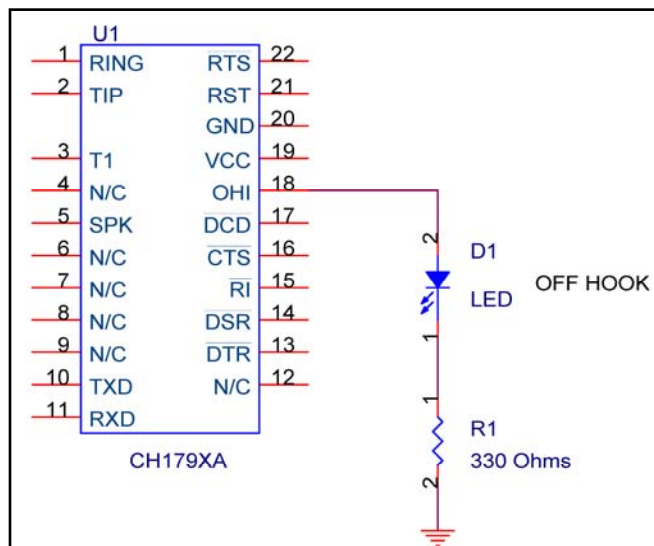

Figure 2. Example of Off Hook Indication using "H" version HS Modem and external LED and resistor.

NOTE

The minimum transmission rate is not stored and will default to 300bps upon execution of reset or upon power up.

Refer to, "AT Commands and S-Registers", for a more detailed discussion of the **+MS** command.

CONNECTING TO THE HOST UART

Since a modem communicates data serially and most host products handle data in a parallel format, a UART is needed to make parallel-to-serial and serial-to-parallel translations.

SUPPORTED FEATURES

AT Command Set. The HS Modem supports the **AT** Command set with extensions and can operate with industry standard communication software. The **AT** Commands are compatible with TR302.2/88-08006.

Serial Host Interface. The HS Modem family operates in asynchronous mode and supports a 5V, RS232- like interface called V.24 (EIA-232-E). Signal levels are TTL rather than RS-232C level compatible, which allows direct connection of the HS Modem to the host's UART without level translating circuitry. See Table 3 for a complete set of pin descriptions.

The modem is controlled by sending serial commands over TXD and by monitoring serial status messages returned on RXD. All other serial interface lines may be utilized for the convenience of a particular application but are not required by the modem. Unused outputs from the HS Modem should be left unconnected. Unused inputs should be tied to the proper logic level. See Table 3.

Speaker Interface. The SPK output reflects the receiver analog input and provides a signal that can be used to monitor call progress. The SPK signal can drive a 300-ohm load directly. Typically, the SPK signal is input into an audio power amplifier and the amplifier, in turn, drives the speaker coil. The speaker is activated with the **ATMn** command. The speaker volume is adjusted using the **ATLn** command; where n is 0, 1, 2, or 3. Increasing numbers correspond to higher volume. Figure 3 indicates one method of driving an external 8-ohm speaker.

Sleep Mode. To minimize power consumption, the HS Family of Modems includes a power reduction feature called Sleep Mode. When activated, the HS Family of Modems will automatically enter Sleep Mode after 1 to 255 seconds of inactivity. The inactivity delay is selected using the **S24** register. The **S24** is set to default to 0 by the factory which disables this feature. The HS Family of Modems returns to normal operation when a ring signal is received or upon an input low signal on the TXD pin. In Sleep Mode, power is reduced to about 1/3 of normal operating power.

Zero Power Mode. The “P” versions of the HS Family of Modems support Zero Power Mode operation. If an application calls for zero power during standby periods, this feature allows the power to the HS Modem to be switched off using external circuitry and then reapplied when the modem’s RI pin becomes active. The HS Modem can thus be powered down to zero current.

Referring to Figure 3, the controller activates the relay switch, supplying power (+5V) to the HS Modem. In this configuration, the ring signal is used to “wake up” the HS Modem when the HS Modem is in the zero power state.

The user supplies an external pull-up resistor (Cermetek recommends 30k ohms) to an active 5V source to limit the current drawn by the when the HS Modem is in zero power mode. An internal blocking diode provides supply isolation.

The pins of the HS Modem will be in an undefined state when powered is switched off. This must be taken into consideration to assure that no unwanted signals are presented to the HS Modem during zero power operation.

Power Supply. The HS Modem module is a complex set of sensitive subsystems. During the course of normal operation, the HS Modem decodes analog signals from the telephone line that are in the millivolt range. Steps must be taken by the user to guarantee that power supply noise on all supply lines, including ground, does not exceed 25mV peak to peak. If necessary, use dedicated power and ground planes.

Failure to provide such operating conditions could cause the HS Modem to malfunction or to function erratically.

The HS Modem family requires +5V \pm 5% supply. It is recommended that bypass capacitors be placed on the power supply as close to the HS Modem’s supply input pins as practical. It is recommended that a 10 μ F or greater tantalum capacitor in parallel with a 0.1 μ F ceramic capacitor be used. The user must also provide shielding from nearby sources of EMI, such as relays, motors and other power supplies.

Automatic Speed/Format Sensing. The HS Modem supports both Command and Data modes of operation.

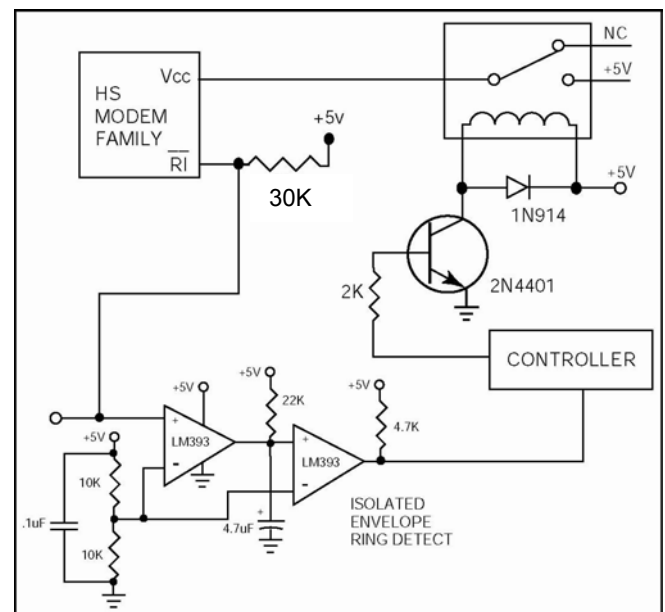

Figure 3. Example of Zero Power Operation.

The HS Modem can automatically determine the speed and format of the data sent from the DTE over the serial interface; and can sense the following broad range of speeds:

| | |
|---------|--|
| CH1794A | 300, 600, 1200, 2400, 4800, 7200, 9600, 12000, 14400, 19200, 38400, and 57600bps. |
| CH1799A | 300, 600, 1200, 2400, 4800, 7200, 9600, 12000, 14400, 16800, 19200, 21600, 24000, 26400, 28800, 38400, 57600, and 115200bps. |
| CH2056A | 300, 600, 1200, 2400, 4800, 7200, 9600, 12000, 14400, 16800, 19200, 21600, 24000, 26400, 28800, 38400, 57600, 115200, and 230400bps. |

The data formats in Table 1 are recognized by the HS Modem family of products. The HS Modem can sense data with mark or space parity and configures itself as described in Table 2.

The HS Modem is trained to a selected speed with an **AT<CR>** training sequence. Thus, the DTE to modem serial interface speed can be set independent of the DCE or line carrier connecting speed (with minor restrictions, see the **AT+ MS** command). This allows greater flexibility when selecting DCE line carrier modulation speed thereby affording the user with optimum data throughput performance. To maximize effective modem data throughput speed, the DTE to modem serial interface speed should be set to the highest speed available without invoking the use of the HS Modem's built-in flow control. Although flow control facilitates communication with higher speed modes by the DTE, use of flow control causes an overall throughput data rate penalty.

Table 1. Data Formats Recognized by HS Modem Family.

| Parity | Data Length (No. of Bits) | No. of Stop Bits | Character Length (No. of Bits) |
|--------|---------------------------|------------------|--------------------------------|
| None | 7 | 2 | 10 |
| Odd | 7 | 1 | 10 |
| Even | 7 | 1 | 10 |
| None | 8 | 1 | 10 |
| Odd | 8 | 1 | 11* |
| Even | 8 | 1 | 11* |

*11 bit characters are sensed, but the parity bits are stripped off during data transmission in Normal and Error Correction modes.

Voice/Tone Injection Port. The HS Modem Family provides pin T1 to allow the user to share the PSTN line interface associated with the modem for voice and DTMF applications. Figure 5 contains a schematic which uses a 5 Volt single supply operational amplifier and indicates one possible configuration for voice/tone utilization.

Refer to Cermetek Application Note #170, 2-4 Wire Converter for Use with CH179X and CH2056 Modems, for an alternative voice/tone implementation that utilizes dual supply operational amplifiers.

Table 2. HS Modem Auto Configuration Based on DTE Configuration.

| DTE Configuration | HS Modem Configuration |
|-------------------|------------------------|
| 7 mark | 7 none |
| 7 space | 8 none |
| 8 mark | 8 none |
| 8 space | 8 even |

All HS Modem products are designed with pin T1 coupled directly to the internal DAA. When using the HS Modem in data mode, T1 should float and be disconnected from any potential signal because any signal on T1 during data operation will affect the HS Modem's output. If T1 is being asserted from another

application, use a relay or zero impedance switch to disconnect T1 when in data mode.

When voice and data are both being used, and the T1 pin is active, it is typical for voice communication to precede data communication. In this case, the following commands should be used to configure the HS Modem to allow for full utilization of the Voice/Tone injection feature. These commands disable auto-answer and eliminate hang-up due to lack of carrier signal.

1. Enter: **ATS0=0<CR>**
2. Enter: **ATS7=255<CR>**
3. Enter: **ATS10=255<CR>**

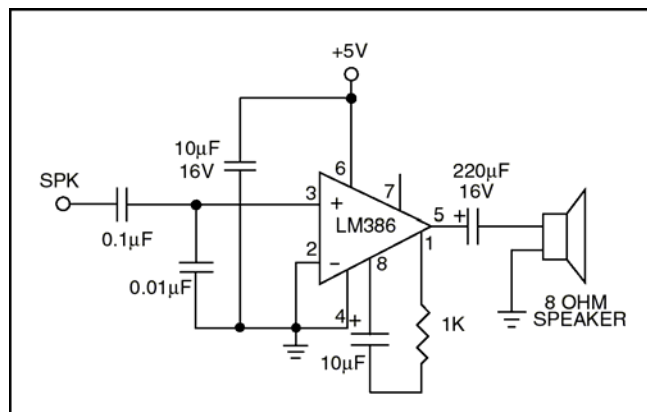

Figure 3. Speaker Control Circuit.

The following command sequences illustrate implementation of common voice/tone port applications.

1. To answer a voice call:
 - (a) Enter: **ATH1<CR>**
 - (b) Switch local voice source into T1
 - (c) Begin Voice Conversation
2. To switch to data mode, switch local voice source from T1:
 - (a) At the Originate Modem, enter: **ATX1<CR>**
 - (b) At the Answer Modem, enter: **ATA<CR>**
3. To disconnect (hang-up) a voice call or data call:
 - (a) Return to control mode by entering: **+++**
 - (b) Enter: **ATH<CR>**
4. To place a voice call using the HS Modem DTMF facilities:
 - (a) Enter: **ATDT1234567<CR>**
Where **1234567** is the phone number
 - (b) Then switch to local voice source

Modem-on-Hold (MOH). The Modem-on-Hold (MOH) feature enables the CH2056A modem to temporarily pause a data call to the Internet by placing the call on hold to allow usage of the same PSTN line to accept an incoming call or to initiate an outgoing voice call.

This feature is available only with a connection to an ISP server supporting MOH. MOH can be executed using the +PMH and +PCW commands. Refer to Cermetek document AT Commands and S-Registers, for more details.

Quick Connect. The Quick Connect feature enables the CH2056A modem to shorten the connect time of subsequent calls to an ISP server supporting quick connect. The Quick Connect feature is controlled via the +PQC command.

PCM Upstream. PCM Upstream boosts the upstream data rates between the CH2056A and the ISP by reducing the upload times for large files and email attachments. A maximum of 48kbps upstream rate is supported with PCM Upstream enabled, in contrast to a maximum of 32.2kbps upstream rate with PCM Upstream not enabled. PCM Upstream is controlled via the +PCM command. PCM Upstream is disabled by default.

NOTE

Modem-on-Hold, Quick Connect and PCM Upstream are only available with the CH2056A modems in V.92 mode.

MODEM CONTROL

The HS Modem may be controlled by sending serial ASCII command sequences. The commands are sent to the modem serially on the TXD pin. After execution of a received command, the modem returns a serial status message that completion status. Refer to Table 5 for a complete list of status messages.

MODEM STATES

The HS Modem can be in either command mode or data mode. When the modem is idle, it is in command mode by default and will recognize commands. When data transmission is in progress, the HS modem is in the data mode state and will not recognize commands. To force the HS Modem to recognize commands, the host must send an "escape sequence" to the HS Modem forcing it out of data mode and into command mode.

The escape sequence consists of a "guard time" (a period where no characters are sent to the modem), followed by 3 escape characters, followed by a second guard time. At power-up, the guard time is set to 1 second, and the escape character is set as "+." Note that a 50 msec delay is required between escape characters. These two parameters can be modified via registers S2 and S12, respectively.

WARNING

The HS Modem family of products has been FCC Part 68 approved as data/FAX modems. Utilization of the Voice/Tone Port requires further registration. The FCC requires that the entire system, including the HS Modem and the handset or DTMF transceiver, adhere to Part 68 rules.

The HS modem will stay off-hook with its carrier on after the escape sequence is received. The HS Modem will return an OK status message when it is ready to accept commands. To put the HS Modem back into data mode, issue command **ATO<CR>**.

THE COMMAND FORMAT

HS Modem commands consist of three elements:

1. The attention sequence,
2. The commands themselves and
3. A terminating carriage return.

Enter: **ATDT1234567<CR>**

Result: Modem goes off-hook and tone dials phone number 1234567.

AT [Commands]<CR>.

Where: **AT** represents attention sequence. **A** and **T** may be either upper or lower case but must be the same case. **[Command]** represents command strings.

Where: **<CR>** represents carriage return (ASCII 13 or HEX 0D)

<LF> represents line feed (ASCII 10 or HEX 0A)

The HS Modem will respond with one of the following status messages depending on whether it is optioned for abbreviated (terse) or English (verbose) status messages.

Result: **0 <CR>** (Terse)

or

Result: **<CR><LF>**

OK

<CR><LF> (Verbose)

After accepting the **AT<CR>** command the HS modem is in idle mode and is ready to accept additional commands.

An alternate attention sequence **A/** may be issued which behaves much like the **AT** sequence except that it causes the last entered command specified with an **AT** prefix to be executed. When given, it must be in upper case ASCII. No carriage return is needed for this command.

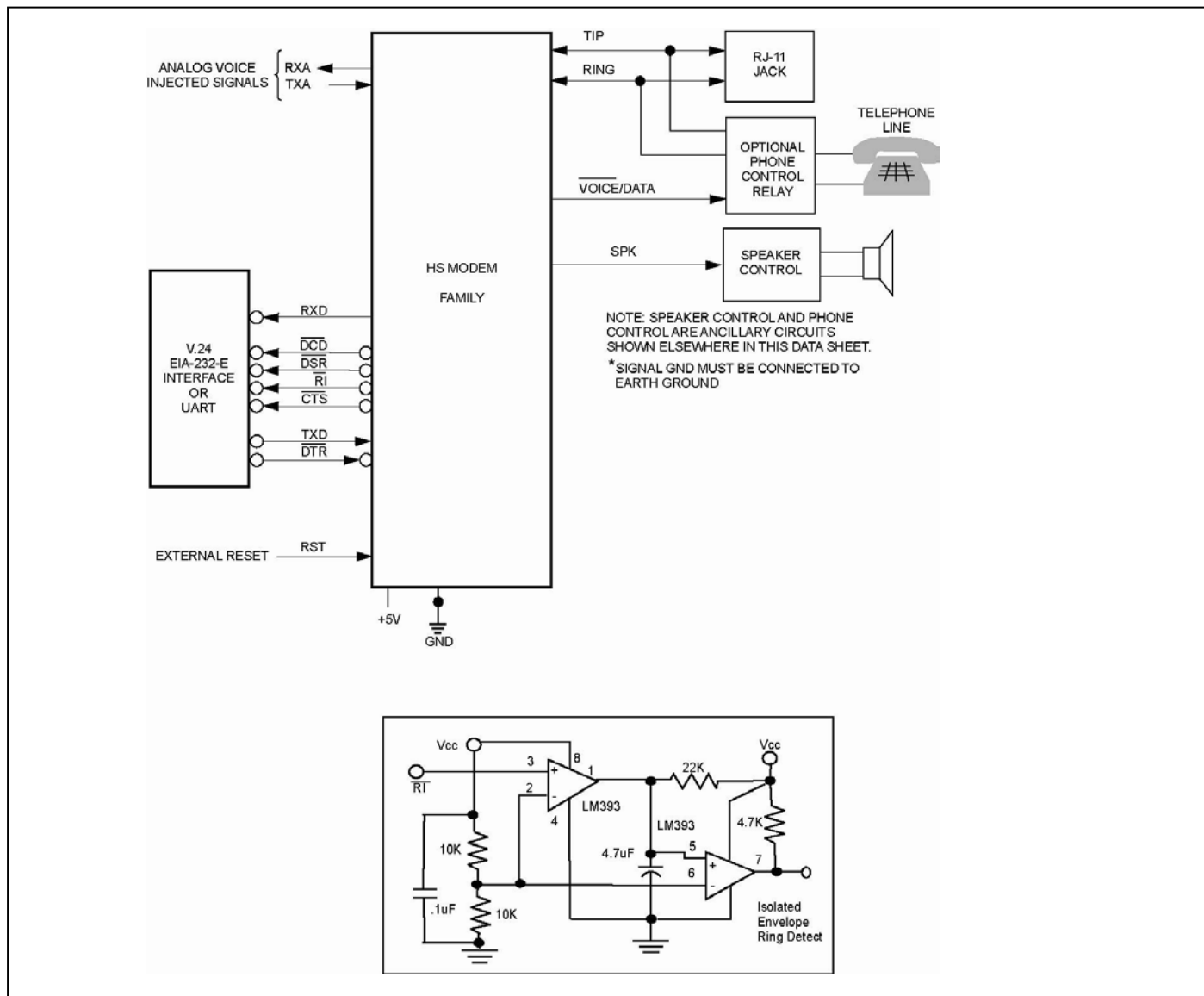

Figure 4. HS Modem Family Application Diagram.

When entering commands to the modem, the backspace character-control-H (ASCII 8 or HEX 08) can be used to edit mistakes. **AT** and **A/** may not be edited however. Multiple commands may be placed on a command line. A command line may be as long as 40 characters, excluding the letters **AT**. By way of example, the command below instructs the HS Modem to configure itself to not echo characters when in command mode (**E0**) and then puts itself in answer mode (**A**).

Enter: **ATE0A<CR>**
 Result: **OK<CR><LF>**

AT Command Set. The available command set is divided into four types of commands: basic commands, ampersand, dial modifiers and percent commands. Refer to the complete list in Table 6.

INITIALIZING THE MODEM

Before commands may be sent to the HS Modem, the modem must be initialized. This is a two step process:

- Step 1. Modem Reset. This is accomplished by applying a hardware-reset pulse to pin RST or by switching the power off then back on.
- Step 2. Initial Modem Training. The modem must be trained to the host DTE speed and parity (odd, even, mark, space or none). These activities are briefly described below.

HS Modem Reset. Upon applying power to the HS Modem, the HS Modem automatically generates an internal reset pulse. The user can also reset the modem externally by applying a high-going reset pulse to the RST pin for at least 10 msec after the +5V power supply has stabilized. Delay sending commands to the HS Mode for 2 seconds after reset has been initiated to allow the HS Modem time to properly reconfigure.

On power up, or when reset is initiated either by the **ATZ<CR>** command or by the RST pin, the modem will reconfigure to its default state with the line carrier modulation speed set to:

1. 14.4kbps for the CH1794A.
2. 33.6kbps for the CH1799A.
3. 57.6kbps for the CH2056A.

If desired, any speed, error correction, or data compression method available on the HS Modem can be locked in, using the **AT\Nn** and/or **AT+MS** commands.

Training the Modem. Each modem must be trained to match the host DTE speed and parity so that it is able to recognize serial asynchronous commands sent to it by the DTE.

The DTE must retrain the modem each time a reset pulse is applied on RST or after a RESET serial command has been issued.

STATUS MESSAGES AND RESULTS CODES

A result code is issued by the HS Modem to the DTE for all commands executed by the HS Modem except dialing commands. Further, various activities on the PSTN are also signaled to the DTE by the HS Modem. All result codes have either a terse, short form version (which is identified by a number followed by a **<CR>**) or a verbose long form English-like message version (which is preceded and terminated with a **<CR>** and **<LF>**).

The user may suppress certain subsets of the non-extended result codes. This is accomplished by selecting subsets of the result code set using the **ATXn** command, where n=0, 1, 2 or 3. Optionally, the user may specify an extended set of results codes (codes above 35) by setting Register S95. See the detailed description of results codes in Table 5.

All **AT** commands, other than dialing commands, will be responded to with either an OK (short form result code 0) or the command is valid or accepted, or with an ERROR (result code 4) if the command is not recognized. The detail contained in the error result codes signaled to the DTE depends on the level of message suppression employed by the user. As can be seen from Table 5, specifying X4 allows the HS Modem to utilize the entire range of non-extended messages, whereas X0 suppresses all but the very basic result codes. Most of the result codes allowed under X1, X2 and X3 are considered call progress status codes and, in practice, are suppressed except for the case of debugging activities. It is recommended that the non-extended result codes be used in all cases.

It should be noted that the default connect result codes 9-20 indicate DTE connection speed, not Carrier Line DCE speed. Hence, a CH1794A will connect at a maximum speed of 19.2kbps (result code 16). The CH1799A will connect at a maximum DTE speed of 38.4kbps (result code of 17) and the CH2056A will connect at a maximum speed of 57.6kbps (result code 18) unless the DTE is forced to a higher speed by selection of data compression. In this case, the maximum DTE to modem speed is 230.4kbps (result code 20).

IMPORTANT NOTE

Result codes 53-64 are supported by the CH1799A and CH2056A. Result codes 165-194 are only supported by the CH2056A. To obtain a detailed status report for a given modem communication configuration, use the **ATV1** command. Executing this command at setup will cause the modem to connect and return a message consisting of **<DTE speed> <modulation> <error protocol> <line speed of connection>**.

Extensions to the basic result code set may be specified by Register S95, which allows for the use of result codes 40-64, 165-194.

LEASED LINE OPTION

The CH179XA-L/CH2056A-L and CH179XAR-L/CH2056AR-L is a leased line version of the CH1799A. Whereas the CH1799A requires an active voltage bearing or wet PSTN line for normal operations (typically, 48VDC on-hook line voltage), the CH179XA-L/CH2056A-L and CH179XAR-L/CH2056AR-L is designed to operate over a non-voltage bearing or dry line.

The CH179XA-L/CH2056A-L and CH179XAR-L/CH2056AR-L will only operate properly on a dry line. Damage will occur if used on a wet line. The CH179XA-L/CH2056A-L and CH179XAR-L/CH2056AR-L does not support ring detect but does support off-hook control. Refer to Cermetek Application Note # 116 for examples and instructions to establish a connection over a leased dry line wire pair. Note that the length of the leased line is limited to 20,000 feet. Use PSTN line protection as recommended in Figure 6B and in Cermetek Application Note # 126. Follow all applicable requirements for FCC Part 68 compliance. The User is responsible to ensure that FCC Part 68 compliance is maintained.

As an alternative, the CH1799A will operate on a leased line if the line is made wet by application of a DC voltage. Refer to Cermetek Application Note # 114.

Table 3. HS Modem Family Pin Descriptions.

| PIN | NAME | TYPE | FUNCTION |
|-----|-------------------------|------|--|
| 1 | RING | I/O | TELCO/TELSET INPUT. Directly connects to the telephone line's RING lead through a user supplied RJ-11C jack. |
| 2 | TIP | I/O | TELCO/TELSET INPUT. Directly connects to the telephone line's TIP lead through a user supplied RJ-11C jack. |
| 3 | T1 | I/O | ANALOG VOICE INJECT. Input (See Figure 5). 2.2V P-P max. Let float if not used. |
| 4 | NC | - | No Connection. |
| 5 | SPK | O | SPEAKER. Audio output for speaker. See speaker control schematic in Figure 5. |
| 6 | NC | - | No Connection. |
| 7 | NC | - | No Connection. |
| 8 | NC | - | No Connection. |
| 9 | NC | - | No Connection. |
| 10 | $\overline{\text{TXD}}$ | I | TRANSMIT DATA. Active Low. Serial Transmit data input. Marking or a binary 1 condition is transmitted when a HIGH is asserted. |
| 11 | $\overline{\text{RXD}}$ | O | RECEIVE DATA. Active Low. Serial Receive data output. Received marking or binary 1 condition is indicated by HIGH. |
| 12 | NC | - | No Connection. |
| 13 | $\overline{\text{DTR}}$ | I | DATA TERMINAL READY. Active LOW. Switching off DTR can either return modem to command state, disconnect phone call, or reset modem. DTR should be set LOW when not used. |
| 14 | $\overline{\text{DSR}}$ | O | DATA SET READY. LOW indicates handshaking with a remote modem is in progress, and/or the data carrier of a remote modem has been detected. Commands &S0 or &S1 must be executed to active to this pin. |
| 15 | $\overline{\text{RI}}$ | O | RING INDICATION. Active Low. This signal follows the frequency of the ringing signal and is normally about 20 to 40 Hz for 2 seconds on with 4 seconds off. This pin is also used for Zero Power option. See Figure 3. |
| 16 | $\overline{\text{CTS}}$ | O | CLEAR-TO SEND. Active LOW. Indicates that the modem is ready to accept data from the DTE. Used for hardware Flow Control of data. |
| 17 | $\overline{\text{DCD}}$ | O | DATA CARRIER DETECT. Active LOW. Indicates a data carrier from a remote modem has been detected. Must be enabled using the &C1 command. |
| 18 | NC | - | No Connection. |
| | OHI | O | OFF-HOOK INDICATION. Active HIGH. Indicates when HS Modem goes off-hook. ONLY present on "H" version products. See Figure 2. |
| 19 | VCC | - | POWER SUPPLY. 5 volts \pm 5% or 3.3 volts \pm 5%.: Noise should be less than 25mV peak to peak. |
| 20 | GND | - | GROUND. Note: Noise should be less than 25mV peak to peak. |
| 21 | RST | I | RESET. Active HIGH. This input must be asserted HIGH for at least 10 ms to reset the modem. RESET is then returned LOW for normal operation. If no system reset is available, let this pin float to enable the internal reset. Input impedance of driving circuit should be <10K. |
| 22 | $\overline{\text{RTS}}$ | I | REQUEST TO SEND. Active LOW. Used for flow control. Should be tied low if not used. |

NOTE: (1) If VCC has a slow power up ramp time, the internal reset may be ineffective.
(2) Do not drive LED's directly from any output. Use Buffers.

WARNING

Operation of the CH179XA-L/CH2056A-L and CH179XAR-L/CH2056AR-L on a standard PSTN line will damage the CH179XA-L/CH2056A-L and CH179XAR-L/CH2056AR-L and void its warranty. Further, operation of the CH179XA-L/CH2056A-L and CH179XAR-L/CH2056AR-L on a dry line without using proper current limiting circuitry as outlined in Cermetek Application Note # 126 may cause damage to the CH179XA-L/CH2056A-L and CH179XAR-L/CH2056AR-L and will also void its warranty.

AT COMMAND APPLICATIONS

Dialing a Phone Number. The Dial command takes the form **Dn**, where n is a string of characters. In the simplest form, n will be only the digits of the phone number to be dialed.

Example: Dial Number.
Enter: **ATD1234567<CR>**
Result: **Modem goes Off-Hook, dials**

In response to this command, the HS Modem goes Off-Hook and dials the telephone number "123-4567" and then waits for a carrier from the distant modem. If no carrier is detected within a given time (the default time is 30 seconds), the HS Modem automatically releases the line and sends a NO CARRIER result code. If a carrier is detected, the HS Modem gives a CONNECT result code and goes on-line, permitting communication with the distant modem.

The Dial command may also be issued without a telephone number. ATD causes the modem to pick up the telephone a line without dialing a number.

Pause During Dialing. When placing a call from an office with a telephone connected to a PBX, it may be necessary to dial an access code (usually the digit 9) to get an outside line. Inserting a comma in the telephone number commands the modem to pause for a specific length of time. The factory default pause time is 2 seconds.

Example: Dial 9, pause, dial number.
Enter: **ATDT9, T1234567<CR>**
Result: **Modem goes Off-Hook, dials**

Multiple commas may be used for a greater delay time.

Touch Tone and Pulse Dialing. The modem can use DTMF (touch-tones) **T**, or dial pulses **P** when dialing a telephone number. If the dial command does not specify which type to use, the modem defaults to the type last specified. The power-on default value is **T**.

Example: Pulse dial 9, pause, touch-tone dial number.

Enter: **ATDP9, T1234567<CR>**
Result: **OK<CR><LF>**

Redial Last Number. Use **A/**, the repeat command, to redial the last telephone number dialed when a busy signal is received.

Go Off-Hook and Return to Command State. The modem can be forced to reenter the command state after going off-hook by issuing the ATDT command with a semi-colon. This is useful when using the modem with an independent DTMF tone generator.

Example: Touch-tone dial 9, pause, go off-hook, return for additional **AT** commands.

Enter: **ATDT9, T;<CR>**
Result: **OK<CR><LF>**

Automatic Answering. Some examples of Auto Answer:

1. Enter: **ATS0=0<CR>** Modem will not auto-answer
2. Enter: **ATS0=1-255<CR>** Modem will answer on 1 to 254 rings

Note that when S0 is set to 0, the HS Modem will not auto-answer.

V.22 Fast Connect. The HS modem family supports non-standard V.22 fast connect protocols. This feature reduces the connect time to 3-4 seconds. However, to utilize the fast connect protocol, this protocol must be supported by both modems. Further, the DCE speed must be set to 1200 baud (i.e., V.22).

To setup the HS modem product to connect utilizing Fast Connect, execute the following commands:

Enter: **AT+MS=V22,0,300,1200,300,1200<CR>**
Result: **OK<CR><LF>**

Enter: **\$F2<CR>**
Result: **OK<CR><LF>**

This forces the modem to communicate using the V.22 protocol and to attempt to connect using Fast Connect. If Fast Connect is not supported by the other modem, the modem will connect using the standard V.22 protocol.

Caller ID (CID). The "C" version of the HS Family supports Caller ID. The **+VCID** command controls reporting and presentation of the data provided by the PSTN Caller ID services. Data is presented to the DTE between the first and the second ring indication. This command affects the data format for incoming calls as the call is being received.

Enter: **AT+VCID=n <CR>**
 Result: **OK<CR><LF>**

Where n is a decimal number corresponding to the selected option as described below.

- 0 Disable Caller ID reporting. (Default.)
- 1 Enables Caller ID with formatted presentation to the DTE. The data presented is in a <Parameter Description> <Value> pair format. The expected pairs are: date, time, name, and caller code (telephone number). ASCII data is presented.
- 2 Enables Caller ID with unformatted presentation to the DTE. The data is presented in a continuous string. HEXADECIMAL data is presented.

Refer to Application Note # 174, Caller ID Feature For CH1786A, CH179XA and CH2056A Modems, for additional information and examples.

The **AT+VRID** command affects the format of the data provided by the PSTN Caller ID services for the last received call. The DTE is presented this data once every time the **+VRID** command is executed.

Enter: **AT+VRID=n<CR>**
 Result: **Data Stream from most recent call**

Where n is a decimal number corresponding to the selected option as described below.

- 0 Reports Caller ID with formatted presentation to the DTE. The data is presented the data items in a <Parameter Description> <Value> pair format. The expected pairs are: date, time, name, and caller code (telephone number).
- 1 Reports Caller ID with unformatted presentation to the DTE.

Refer to Application Note # 174, Caller ID Feature For CH1786A, CH179XA and CH2056A Modems, for additional information and examples.

IMPORTANT NOTE

Caller ID (CID) requires that the PSTN service provider supply the required data. The Caller ID feature will report the NULL string if the CID service is not activated by the PSTN service provider.

PHONE LINE CONNECTION GUIDELINES

1. The HS Modem must be mounted in the final assembly such that it is isolated from exposure to any hazardous voltages within the assembly. Adequate separation and restraint of cables and cords must be provided.
2. The circuitry from the HS Modem to the telephone line interface must be provided in wiring that carries no other circuitry other than that specifically allowed in the FCC rules (such as A and A1 leads).
3. Connection to phone line should be made through an RJ-11C jack.
4. PCB traces from the modem's RING and TIP pins to the RJ-11C jack must be 0.1 inch spacing or greater to one another and 0.2 inch spacing or greater to all other traces. The traces should have a nominal width of 0.020 inches or greater.
5. The RING and TIP PCB traces should be as short as possible and oriented to prevent coupling other high speed or high frequency signals present on the host circuit PCB.
6. No additional circuitry other than that shown in Figure 6 may be connected between the modem module and the RJ-11C jack. Doing so will invalidate the FCC approval.
7. The HS Modem, the RJ-11C jack, the interfacing circuitry and all PCB traces in between, must be contained on a PCB with a 94 V-0 flammability rating.
8. The supplied FCC registration label must be applied visibly on the outside of the product.
9. The product's User Manual must provide the user with instructions for connection and use as recommended in the FCC Registration Section below.

The HS modem family supports Caller ID.

CANADIAN APPROVALS

The HS Modem family is approvable for use by Industry Canada to CSA CS-03 Part I. The CH1799A has been approved by Industry Canada and the registration number for CH1799A is listed on page 1. Approval for other products in this family are available upon request.

PAN-EUROPEAN TBR21 APPROVALS

The CH179XA/CH2056A-B/ET-B and CH1799AR/CH2056AR-B/ET-B products have been designed to meet the requirements of *ETSI TBR – 021 Pan-European Approval for Connection to Analogue Public Switched Telephone Networks* in addition to the FCC Part 68 conveyed approval, Canadian DOT CSA CS-03 Part I compliance and UL 60950 Edition 3/CSA C22.2 950 recognition. Test reports (as required for CE marking) demonstrating TBR21 compliance are available upon request.

HS MODEM HANDLING AND ASSEMBLY RECOMMENDATIONS

The HS Modem contains static-sensitive components and should only be handled by personnel and in areas that are properly protected against static discharge.

There are two mounting techniques that are recommended for physically connecting the HS Modem to a PCB:

1. Direct soldering.
2. Sockets.

Direct Soldering. The HS Modem may be wave soldered onto a circuit card. All HS Modem products are hermetically sealed and will not be harmed by industry standard wave soldering processes.

Socketing. The socketing approach to mounting eliminates cleaning and desoldering concerns. When the socket is used, it must make a solid connection to all pins. Failure to do so will cause unreliable or intermittent operation. Also, steps should be taken to assure that the module remains tightly seated in the socket after the end product is shipped. Cermetek recommends socket CES-150-01-T-S by Samtec, 50 pin strip socket.

FCC REGISTRATION

All products in the HS Modem family are registered with the FCC (except the CH1799A-L/CH1799AR-L) under Part 68. To maintain the validity of the registration, you must serve notice to the end user of the product of several restrictions the FCC places on the modem and its use.

In addition to restriction notification, the FCC requires that Cermetek make all repairs to all products in the HS Modem family. If repairs are necessary after installation of the HS Modem and the end product has been delivered to the end user, the end product must be returned to the end product supplier where the HS Modem can be removed and then forwarded to Cermetek for repair. The following notice is recommended and should be included in the end product's user manual.

FOR YOUR USER'S MANUAL

The Part 68 rules require the following (or equivalent) be provided to the end user of the equipment containing a DAA:

Type of Service. The (insert end product name) is designed to be used on standard device telephone lines. It connects to the telephone line by means of a standard jack called the USOC RJ-11C (or USOC RJ45S). Connection to telephone-company-provided coin service (central office implemented systems) is prohibited. Connection to party lines service is subject to state tariffs.

Changes in Attestation Procedure for Plugs and Jacks. (Name of applicant) attests that the network interface plugs or jacks used on this equipment comply with and will continue to comply with the mechanical requirements specified in Part 68, Sub-part F, specifically the dimensions, tolerances and metallic plating requirements. The compliance of these connectors will be assured by purchase specifications and incoming inspection. Documentation of such specifications and/or inspections will be provided by the FCC within 30 days of their request for the same.

Telephone Company Procedure. The goal of the telephone company is to provide you with the best service it can. In order to do this, it may occasionally be necessary for them to make changes in their equipment, operations or procedures. If these changes might effect your service or the operation of your equipment, the telephone company will give you notice, in writing, to allow you to make any changes necessary to maintain uninterrupted service.

In certain circumstances, it may be necessary for the telephone company to request information from you concerning the equipment which you have connected to your telephone line. Upon request of the telephone company, provide the FCC registration number and the ringer equivalence number (REN); both of these items are listed on the equipment label. The sum of all of the REN's on your telephone lines should be less than five in order to assure proper service from the telephone company. In some cases a sum of five may not be useable on a given line. Consult your telephone provider.

If Problems Arise. If any of your telephone equipment is not operating properly, you should immediately remove it from you telephone line, as it may cause harm to the telephone network. If the telephone company notes a problem, they may temporarily discontinue service. When practical, they will notify you in advance of this disconnection. If advance notice is not feasible, you will be notified as soon as possible.

When you are notified, you will be given the opportunity to connect the problem and informed of your right to file a complaint with the FCC. Contact your local telephone service provider if you have any questions about your phone line.

In the event repairs are ever needed on the (insert your product name), they should be performed by (insert your company name), or an authorized representative or (insert your company name). For information contact: (insert your company address).

DEFAULT STATUS, PERFORMANCE AND SPECS

Prior to delivery, Cermetek installs into each HS Modem the following default Configuration Profile:

Default Connect Speeds (DCE) are 14,400bps, 33,600bps and 57,600bps for CH1794A, CH1799A and CH2056A respectively
 Serial port data rate auto baud enabled
 Bell 212A operation at 1200bps
 Parity – none
 Auto answer disabled
 Command echo ON
 All result codes enabled – except \REL codes
 Wait for dial tone before dialing – 2 seconds
 Dials with touch-tone (T)
 Detects busy signal (ATX4)
 Full word result codes – non-extended
 Pulse dial make/break ratio = 39/61-10pps
 Test timer set to 0 seconds, test modes disabled
 Inactivity timer set to 0 minutes
 CTS always active
 DSR always active
 DCD is ignored
 RTS to CTS delay - .01 seconds
 DTR always active – hang up after transition
 Long space disconnect disabled
 Speaker enabled but off when receiving carrier
 Speaker volume set to low

Local modem will not grant RDL request from remote modem

Guard tones disabled

Minimum DTR pulse width = .05 seconds

Ring count – 00

Escape code character = 43 (+)

Flash to on hook = 70 msec

Auto speed detection enabled

DTE connect speed, connect messages

Back space character = 08 (BS) Carriage return character = 13 (CR)

Line feed Character = 10 (LF)

Duration of wait for dial tone = 2 seconds

Duration of wait for carrier after dialing = 50 seconds

Carrier detect response time = 0.6 seconds

Escape code guard time = 1 second

Length of use after comma = 2.0 seconds

Last carrier to hang up delay = 1.4 seconds

DTMF interdigit delay = .095 seconds

Auto sync address or address detection = 0

Connection detected at DTE – Highest speed 38,400kbps

Auto retrain enabled – 30 seconds attempts

MNP error correction mode can be negotiated (&Q5)

MNP – non-extended service selected

MNP error correction block size is 128 characters selected

Data compression – negotiation enabled

Transmit break length is 0.3 seconds

All breaks are transmitted in sequence with data

Serial port flow control enabled = RTS/CTS

XON/XOFF flow control characters selected

IMPORTANT NOTE

Upon power-up the HS Modem will recall user profile 0 which may override some of the above Factory Defaults. If desired the user may, at their option, save the factory defaults in user profile 0.

Table 4. Result Code Summary.

| Result Code Form | | n is ATXn Command | | | | | Notes |
|------------------|---------------------|-------------------|---|---|---|---|-------|
| Terse or Short | Verbose or Long | 0 | 1 | 2 | 3 | 4 | |
| +F4 | +FCERROR | X | X | X | X | X | |
| 0 | OK | X | X | X | X | X | |
| 1 | CONNECT | X | X | X | X | X | |
| 2 | RING | X | X | X | X | X | |
| 3 | NO CARRIER | X | X | X | X | X | |
| 4 | ERROR | X | X | X | X | X | |
| 5 | CONNECT 1200 | 1 | X | X | X | X | |
| 6 | NO DIAL TONE | 3 | 3 | X | X | X | |
| 7 | BUSY | 3 | 3 | 3 | X | X | |
| 8 | NO ANSWER | X | X | X | X | X | |
| 9 | CONNECT 0600 | 1 | X | X | X | X | |
| 10 | CONNECT 2400 | 1 | X | X | X | X | |
| 11 | CONNECT 4800 | 1 | X | X | X | X | |
| 12 | CONNECT 9600 | 1 | X | X | X | X | |
| 13 | CONNECT 7200 | 1 | X | X | X | X | |
| 14 | CONNECT 12000 | 1 | X | X | X | X | |
| 15 | CONNECT 14400 | 1 | X | X | X | X | |
| 16 | CONNECT 19200 | 1 | X | X | X | X | |
| 17 | CONNECT 38400 | 1 | X | X | X | X | |
| 18 | CONNECT 57600 | 1 | X | X | X | X | |
| 19 | CONNECT 115200 | 1 | X | X | X | X | |
| 20 | CONNECT 230400 | X | X | X | X | X | |
| 22 | CONNECT 75TX/1200RX | 1 | X | X | X | X | |
| 23 | CONNECT 1200TX/75RX | 1 | X | X | X | X | |
| 24 | DELAYED | 4 | 4 | 4 | 4 | X | |
| 25 | MESSAGE-WAITING | X | X | X | X | X | |
| 32 | BLACKLISTED | 4 | 4 | 4 | 4 | X | |
| 33 | FAX | X | X | X | X | X | |
| 35 | DATA | X | X | X | X | X | |
| 39 | +MRR: 75 | X | X | X | X | X | |
| 40 | +MRR: 300 | X | X | X | X | X | |
| 42 | +MRR: 600 | X | X | X | X | X | |
| 44 | +MRR: 1200/75 | X | X | X | X | X | |
| 45 | +MRR: 75/1200 | X | X | X | X | X | |
| 46 | +MRR: 1200 | X | X | X | X | X | |
| 47 | +MRR: 2400 | X | X | X | X | X | |
| 48 | +MRR: 4800 | X | X | X | X | X | |
| 49 | +MRR: 7200 | X | X | X | X | X | |
| 50 | +MRR: 9600 | X | X | X | X | X | |
| 51 | +MRR: 12000 | X | X | X | X | X | |
| 52 | +MRR: 14400 | X | X | X | X | X | |
| 53 | +MRR: 16800 | X | X | X | X | X | 2 |
| 54 | +MRR: 19200 | X | X | X | X | X | 2 |
| 55 | +MRR: 21600 | X | X | X | X | X | 2 |
| 56 | +MRR: 24000 | X | X | X | X | X | 2 |
| 57 | +MRR: 26400 | X | X | X | X | X | 2 |
| 58 | +MRR: 28800 | X | X | X | X | X | 2 |
| 59 | CARRIER 16800 | 1 | X | X | X | X | 2 |
| 61 | CARRIER 21600 | 1 | X | X | X | X | 2 |
| 62 | CARRIER 24000 | 1 | X | X | X | X | 2 |
| 63 | CARRIER 26400 | 1 | X | X | X | X | 2 |
| 64 | CARRIER 28800 | 1 | X | X | X | X | 2 |
| 66 | +DR: ALT | X | X | X | X | X | |

Table 4. Result Code Summary (Continuation).

| Result Code Form | | n is ATXn Command | | | | | Notes |
|------------------|------------------------|-------------------|---|---|---|---|-------|
| Terse or Short | Verbose or Long | 0 | 1 | 2 | 3 | 4 | |
| 67 | +DR: V42B | X | X | X | X | X | |
| 68 | +DR: V44 | X | X | X | X | X | |
| 69 | +DR: None | X | X | X | X | X | |
| 70 | +ER: NONE | X | X | X | X | X | |
| 77 | +ER: LAPM | X | X | X | X | X | |
| 78 | +MRR: 31200 | X | X | X | X | X | 2 |
| 79 | +MRR: 33600 | X | X | X | X | X | 2 |
| 80 | +ER: ALT | X | X | X | X | X | |
| 81 | +ER: ALT-CELLULAR | X | X | X | X | X | |
| 83 | LINE IN USE | X | X | X | X | X | |
| 84 | CONNECT 33600 | 1 | X | X | X | X | 2 |
| 85 | OFF-HOOK INTRUSION | X | X | X | X | X | |
| 86 | LINE REVERSAL DETECTED | X | X | X | X | X | |
| 87 | NO LINE | X | X | X | X | X | 2 |
| 91 | CONNECT 31200 | 1 | X | X | X | X | |
| 130 | +ILRR | X | X | X | X | X | |
| 134 | +MCR: B103 | X | X | X | X | X | |
| 135 | +MCR: B212 | X | X | X | X | X | |
| 136 | +MCR: V21 | X | X | X | X | X | |
| 137 | +MCR: V22 | X | X | X | X | X | |
| 138 | +MCR: V22B | X | X | X | X | X | |
| 139 | +MCR: V23 | X | X | X | X | X | |
| 139 | +MCR: V23C | X | X | X | X | X | |
| 140 | +MCR: V32 | X | X | X | X | X | |
| 141 | +MCR: V32B | X | X | X | X | X | |
| 142 | +MCR: V34 | X | X | X | X | X | 3 |
| 145 | +MCR: V90 | X | X | X | X | X | 3 |
| 146 | +MCR: V92 | X | X | X | X | X | 3 |
| 147 | +MCR: V92 | X | X | X | X | X | 3 |
| 150 | +MRR: 32000 | X | X | X | X | X | 3 |
| 151 | +MRR: 34000 | X | X | X | X | X | 3 |
| 152 | +MRR: 36000 | X | X | X | X | X | 3 |
| 153 | +MRR: 38000 | X | X | X | X | X | 3 |
| 154 | +MRR: 40000 | X | X | X | X | X | 3 |
| 155 | +MRR: 42000 | X | X | X | X | X | 3 |
| 156 | +MRR: 44000 | X | X | X | X | X | 3 |
| 157 | +MRR: 46000 | X | X | X | X | X | 3 |
| 158 | +MRR: 48000 | X | X | X | X | X | 3 |
| 159 | +MRR: 50000 | X | X | X | X | X | 3 |
| 160 | +MRR: 52000 | X | X | X | X | X | 3 |
| 161 | +MRR: 54000 | X | X | X | X | X | 3 |
| 162 | +MRR: 56000 | X | X | X | X | X | 3 |
| 165 | CONNECT 32000 | X | X | X | X | X | 3 |
| 166 | CONNECT 34000 | X | X | X | X | X | 3 |
| 167 | CONNECT 36000 | X | X | X | X | X | 3 |
| 168 | CONNECT 38000 | X | X | X | X | X | 3 |
| 169 | CONNECT 40000 | X | X | X | X | X | 3 |
| 170 | CONNECT 42000 | X | X | X | X | X | 3 |
| 171 | CONNECT 44000 | X | X | X | X | X | 3 |
| 172 | CONNECT 46000 | X | X | X | X | X | 3 |
| 173 | CONNECT 48000 | X | X | X | X | X | 3 |
| 174 | CONNECT 50000 | X | X | X | X | X | 3 |
| 175 | CONNECT 52000 | X | X | X | X | X | 3 |
| 176 | CONNECT 54000 | X | X | X | X | X | 3 |
| 180 | CONNECT 28000 | X | X | X | X | X | 3 |

Table 4. Result Code Summary (Continuation).

| Result Code Form | | n is ATXn Command | | | | | Notes |
|------------------|-----------------------|-------------------|---|---|---|---|-------|
| Terse or Short | Verbose or Long | 0 | 1 | 2 | 3 | 4 | |
| 181 | CONNECT 29333 | X | X | X | X | X | 3 |
| 182 | CONNECT 30667 | X | X | X | X | X | 3 |
| 183 | CONNECT 33333 | X | X | X | X | X | 3 |
| 184 | CONNECT 34667 | X | X | X | X | X | 3 |
| 185 | CONNECT 37333 | X | X | X | X | X | 3 |
| 186 | CONNECT 38667 | X | X | X | X | X | 3 |
| 187 | CONNECT 41333 | X | X | X | X | X | 3 |
| 188 | CONNECT 42667 | X | X | X | X | X | 3 |
| 189 | CONNECT 45333 | X | X | X | X | X | 3 |
| 190 | CONNECT 46667 | X | X | X | X | X | 3 |
| 191 | CONNECT 49333 | X | X | X | X | X | 3 |
| 192 | CONNECT 50677 | X | X | X | X | X | 3 |
| 193 | CONNECT 53333 | X | X | X | X | X | 3 |
| 194 | CONNECT 54377 | X | X | X | X | X | 3 |
| 195 | +MRR: 28000 | X | X | X | X | X | 3 |
| 196 | +MRR: 29333 | X | X | X | X | X | 3 |
| 197 | +MRR: 30667 | X | X | X | X | X | 3 |
| 198 | +MRR: 33333 | X | X | X | X | X | 3 |
| 199 | +MRR: 34667 | X | X | X | X | X | 3 |
| 200 | +MRR: 37333 | X | X | X | X | X | 3 |
| 201 | +MRR: 38667 | X | X | X | X | X | 3 |
| 202 | +MRR: 41333 | X | X | X | X | X | 3 |
| 203 | +MRR: 42667 | X | X | X | X | X | 3 |
| 204 | +MRR: 45333 | X | X | X | X | X | 3 |
| 205 | +MRR: 46667 | X | X | X | X | X | 3 |
| 206 | +MRR: 49333 | X | X | X | X | X | 3 |
| 207 | +MRR: 50667 | X | X | X | X | X | 3 |
| 208 | +MRR: 53333 | X | X | X | X | X | 3 |
| 209 | +MRR: 54667 | X | X | X | X | X | 3 |
| 210 | +MRR: 25333 | X | X | X | X | X | |
| 211 | +MRR: 26667 | X | X | X | X | X | |
| 212 | +MRR: 25333 | X | X | X | X | X | |
| 213 | +MRR: 22666 | X | X | X | X | X | |
| 214 | DIGITAL LINE DETECTED | X | X | X | X | X | |

TABLE 4 NOTES

1. An "X" in a column indicates that the message (either the long form if verbose, or the value only for short form) will be generated when that particular value of "n" (shown at the top of the column) has been selected by the use of Xn. A numeral indicates which more explicit message will be output for that X option.
2. Applicable to CH1799A and CH2056A models only.
3. Applicable to CH2056A models only.

Table 5. AT Command Summary.

| Command | Function |
|----------------|---|
| A/ | Re-execute command |
| A | Go off-hook and attempt to answer call |
| B0 | Select CCITT connection at 300 or 1200bps |
| B1 | Sect Bell connection at 300 or 1200bps |
| Dn | Dial modifier P Pulse Dial T Touch Tone Dial W Wait for Dial Tone ; Return to Command State @ Wait for Quiet Answer Command ! Flash Hook , Pause 0-9/ABCD Dial Digits/Characters & wait for credit card dial tone ^ Toggles calling tone L Redial last number *,# Star digit – tone dialing S=n Dial the number and store in Directory, n= 0 to 3 |
| E0 | Disable command echo |
| E1 | Enable command echo |
| H, H0 | Initiate a hang-up sequence |
| H1 | If on-hook, go off-hook and enter command mode |
| L0 | Set low speaker volume |
| L1 | Set low speaker volume |
| L2 | Set medium speaker volume |
| L3 | Set high speaker volume |
| M0 | Speaker off |
| M1 | Speaker on during hand shaking and speaker off while receiving carrier |
| M2 | Speaker on during hand shaking and while receiving carrier |
| M3 | Speaker off during dialing and receiving carrier and speaker on during answering |
| O0 | Go on-line |
| O1 | Go on-line and initiate a retrain sequence |
| Sn | Select S Register n |
| Sn=m | Write value m to S Register n |
| Sn? | Read the value of S Register n |
| ? | Returns Last addressed S Register value |
| V0 | Short Form Result Code Option |
| V1 | Long Form Result Code Option |
| W0 | Reports DTE Speed |
| W1 | Reports DCE Speed and Error Correction |
| W2 | Reports DCE Speed Only |
| X1, X2, X3, X4 | Result Code Reporting Options |
| +++ | Escape Code Sequence |
| Z0, Z1 | The modem performs soft reset. Restore stored profile 0 or 1 after reset |

Table 5. AT Command Summary (Continuation).

| Command | Function |
|--------------|--|
| &C0 | Force DCD active regardless of the carrier state |
| &C1 | DCD to follow the carrier state |
| &D0 | Modem ignores DTR |
| &D1 | Modem assumes command state |
| &D2 | Modem hangs up, assumes command state and disables auto-answer |
| &D3 | Modem assumes initialization state |
| &F0 | Restore Factory configuration 0 |
| &F1 | Restore Factory configuration 1 |
| &G0, 1, 2 | Guard Tone Options |
| &K0 | Disable DTE/DCE flow control |
| &K1,2 | Not Supported |
| &K3 | Enable RTS/CTS DTE/DCE flow control |
| &K4 | Enable XON/XOFF DTE/DCE flow control |
| &K5 | Enable transparent XON/XOFF flow control |
| &P0, 1, 2, 3 | Make to Break Ratio Options |
| &Q0 | Select direct asynchronous mode |
| &Q1,2,3,4 | Not Supported |
| &Q5 | Modem negotiates an error corrected link |
| &R0 | CTS tracks RTS |
| &R1 | CTS always on |
| &S0 | DSR always on |
| &S1 | DSR active after answer tone detected and inactive after loss of carrier |
| &T0 | Terminate Loopback Test |
| &T1 | Initiate Analog Loopback Test |
| \Bn | Send break of n x 100 msec (n=0 to 9) |
| \N0 | Select normal speed buffered mode |
| \N1 | Select direct mode |
| \N2 | Select reliable mode |
| \N3 | Select auto reliable mode |
| \N4 | Force LAPM mode |
| \N5 | Force MNP mode |
| \V0 | Connect messages are controlled by the command settings X, W, and S95 |
| \V1 | Connect messages are displayed in the single line format |

MODULATION COMMANDS

| | |
|-----------|--|
| +MS | Select modulation |
| +MCR=n | Carrier protocol n reporting |
| +MR=n | Select extended Modulation Reporting of +MCR and +MRR to DTE |
| +MRR=m, n | Report Transmit m and Receive n DCE rates to DTE |

Table 5. AT Command Summary (Continuation).

| Command | Function |
|----------------------|---|
| V.92 COMMANDS | |
| +PCW | Enable/Disable Call Waiting Detection |
| +PCM | Enable/Disable PCM Upstream |
| +PIG | PCM Upstream Ignore |
| +PMH | Enable/Disable MOH |
| +PMHF | MOH Hook Flash |
| +PMHT | MOH Timer |
| +PMHR | Initiate MOH |
| +PQC | Enable/Disable Quick Connect |
| +PSS | Use Short Startup Sequence |
| +QCPC | Force Full Startup Sequence |
| +QCPS | Enable/Disable Quick Connect Profile Save |

CALLER ID COMMANDS

| | |
|-------|---|
| +VCID | Select data presentation format n (0-2) for incoming calls. |
| +VRID | Select data presentation format n (0-1) for most recently received incoming call. |

ERROR CORRECTING COMMANDS

| | |
|-----|---|
| %C0 | Disable data compression. |
| %C1 | Enable MNP5 data compression. |
| %C2 | Enable V.42bis data compression |
| %C3 | Enable both V.42bis and MNP 5 compression |

STORED PROFILE COMMANDS

| | |
|-------|---|
| &V | Display current configuration |
| &W0 | Store the active profile in NVRAM profile 0 |
| &W1 | Store the active profile in NVRAM profile 1 |
| &Y0 | Recall stored profile 0 upon power up |
| &Y1 | Recall stored profile 1 upon power up |
| &Zn=x | Store dial string x (31 digits max) to location n (0-3) |

MNP10 COMMANDS

| | |
|-----|----------------------------------|
| -K0 | Disable MNP 10 extended services |
| -K1 | Disable MNP 10 extended services |
| -K2 | Disable MNP 10 extended services |

FAX COMMANDS

| | |
|--------------|---|
| +FCLASS=n | Service Class |
| +F<cmd>? | Report active configuration for specified command cmd |
| +F<cmd>=? | Report capabilities for specified command cmd |
| +FAA=n | Data/Fax Auto Answer |
| +FAE=<value> | Auto Answer |

Table 5. AT Command Summary (Continuation).

| Command | Function |
|-----------------------|---|
| +FLO | Flow Control |
| +FAR=<off/on> | Adaptive reception control |
| +FCL=<time> | Carrier loss timeout |
| +FDD=<value> | Double escape character replacement control |
| +FIT=<time>, <action> | DTE inactivity timeout |
| +FPR=<rate> | Fixed DTE Rate |
| +FMI? | Report Manufacturer ID |
| +FMM? | Report Model ID |
| +FMR? | Report Revisions ID |
| +FRM=n | Receive Data with n protocol |
| +FRS=<time> | Wait for silence |
| +FTM=n | Transmit Data with n protocol |

Table 5. AT Command Summary (Continuation).

| Command | Function |
|-------------|---|
| +FRH=n | Receive Data with HDLC Framing with n protocol |
| +FTH=n | Transmit Data with HDLC Framing with n protocol |
| +FTS=<time> | Wait for silence |
| +FTS=n | Stop Transmission and Wait |

FAST CONNECT COMMANDS

| | |
|----------|-----------------------------|
| \$F0 | Normal connection (Default) |
| \$F1,3,4 | Not Supported |
| \$F2 | V.22 Fast Connect |

IDENTIFICATION COMMANDS

| | |
|----|--------------------------------------|
| I0 | Reports product code |
| I3 | Reports firmware Identification code |

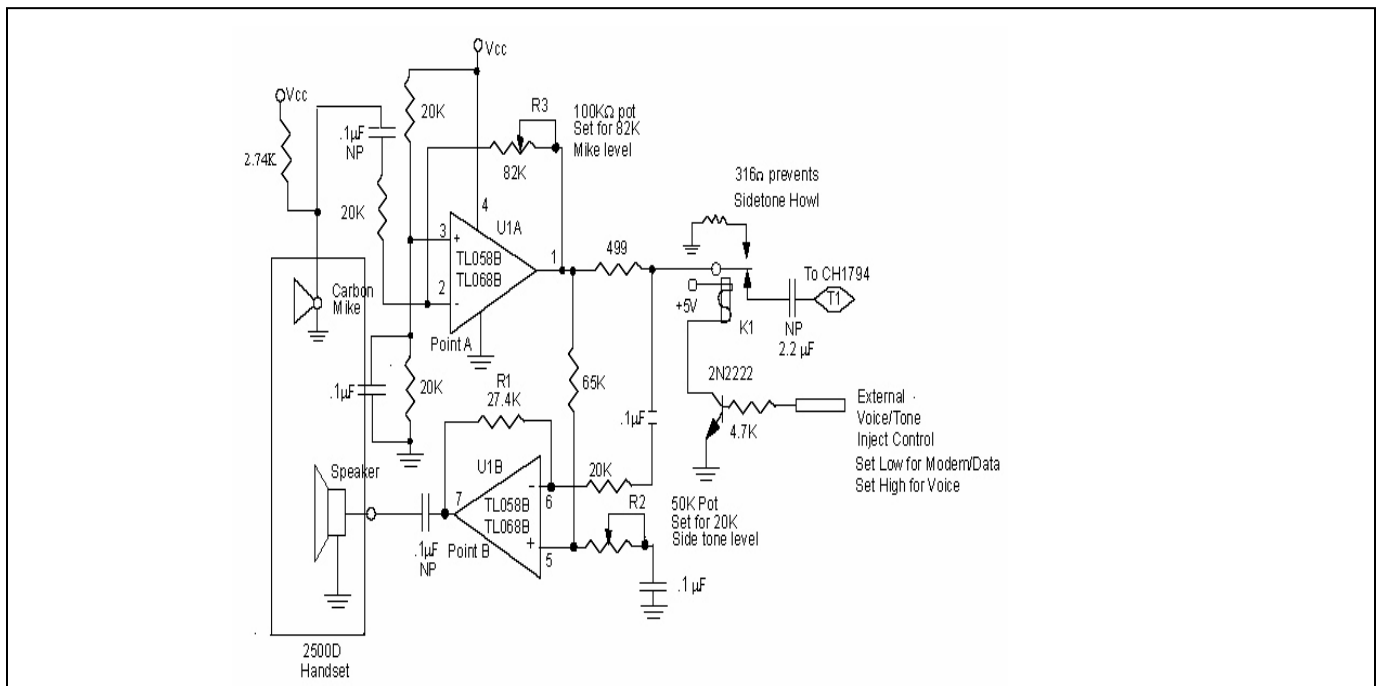

Figure 5. Schematic Illustrating Implementation of Voice Injection Feature.

Table 6. S-Register Summary.

| Register | Function | Range | Units | Saved | Firmware Defaults | Factory Defaults |
|----------|---|--------|------------|-------|-------------------|------------------|
| S0 | Rings to Auto-Answer | 0-255 | rings | * | 000 | 001 |
| S1 | Ring Counter | 0-255 | rings | | 000 | 000 |
| S2 | Escape Character | 0-255 | ASCII | * | 043 | 043 |
| S3 | Carriage Return Character | 0-127 | ASCII | | 013 | 013 |
| S4 | Line Feed Character | 0-127 | ASCII | | 010 | 010 |
| S5 | Backspace Character | 0-255 | ASCII | | 008 | 008 |
| S6 | Wait Time before Dial Tone or Blind Dialing | 2-255 | s | * | 002 | 002 |
| S7 | Wait Time for Carrier, Silence or Dial Tone | 1-255 | s | * | 050 | 050 |
| S8 | Pause Time for Dial Delay Modifier | 0-255 | s | * | 002 | 002 |
| S9 | Carrier Detect Response Time | 1-255 | 0.1s | * | 006 | 006 |
| S10 | Carrier Loss Disconnect Delay | 1-255 | 0.1s | * | 014 | 014 |
| S11 | DTMF Tone Duration | 50-255 | 0.001s | * | 095 | 095 |
| S12 | Escape Prompt Delay | 0-255 | 0.02s | * | 050 | 050 |
| S13 | Reserved | - | - | | 000 | 000 |
| S14 | General Bit Mapped Options Status | - | - | * | 146 (92H) | 146 (92H) |
| S15 | Reserved | - | - | | 000 | 000 |
| S16 | Test Mode Bit Mapped Options Status (&T) | - | - | | 000 | 000 |
| S17 | POS Option | - | - | | 000 | 000 |
| S19 | Reserved | - | - | | 000 | 000 |
| S20 | Reserved | - | - | | 000 | 000 |
| S21 | V.24/General Bit Mapped Options Status | - | - | | 052 (34H) | 100 (74H) |
| S22 | Speaker/Results Bit Mapped Options Status | - | - | | 117 (75H) | 117 (75H) |
| S23 | General Bit Mapped Options Status | - | - | | 000 | 000 |
| S24 | Sleep Inactivity Timer | 0-255 | s | | 000 | 000 |
| S25 | Delay to DTR off | 0-255 | s or 0.01s | | 005 | 005 |
| S26 | RTS-to-CTS Delay | 0-255 | 0.01s | | 001 | 001 |
| S27 | General Bit Mapped Options Status | - | - | | 073 (49H) | 073 (49H) |
| S28 | General Bit Mapped Options Status | - | - | | 000 | 000 |
| S29 | Flash Dial Modifier | 0-255 | 0.01s | | 070 | 070 |
| S30 | Disconnect Inactivity Timer | 0-255 | 10s | | 000 | 000 |
| S31 | General Bit Mapped Options Status | - | - | | 192 (C0H) | 192 (C0H) |
| S36 | LAPM Failure Control | - | - | * | 007 | 007 |
| S37 | Line Connection Speed | - | - | | 000 | 000 |
| S38 | Delay Before Forced Hang-up | 0-255 | s | | 020 | 020 |
| S39 | Flow Control Bit Mapped Options Status | - | - | | 003 | 003 |
| S40 | General Bit Mapped Options Status | - | - | * | 104 (68H) | 104 (68H) |
| S41 | General Bit Mapped Options Status | - | - | * | 195 (C3H) | 195 (C3H) |
| S43-S45 | Reserved | - | - | | - | - |
| S46 | Data Compression Control | - | - | * | 138 | 138 |
| S48 | V.42 Negotiation Control | - | - | | 007 | 007 |
| S82 | LAPM Break Control | - | - | | 000 | 000 |
| S86 | Call Failure Reason Code | 0-26 | - | | 021 | 021 |
| S91 | PSTN Transmit Attenuation Level | 8-15 | dBm | | 11 | 11 |
| S92 | FAX Transmit Attenuation Level | 0-15 | dBm | | 10 | 10 |
| S95 | Result Code Messages Control | - | - | * | 000 | 000 |
| S210 | V.34 Symbol Rate | 0-255 | - | | 13 (0DH) | 13 (0DH) |

- NOTES:**
- Parameters indicated with a (*) in the Saved column may be stored in User Profile n=0, 1 by executing the appropriate &Wn command.
 - A stored Profile is a subset of allowed parameters and is comprised of those parameters displayed with the &V command.
 - Factory Default values that are different from the Firmware Default values are highlighted in **BOLD**.
 - Restore Factory Default values using Zn command.
 - Restore Firmware Default values using &Fn command.

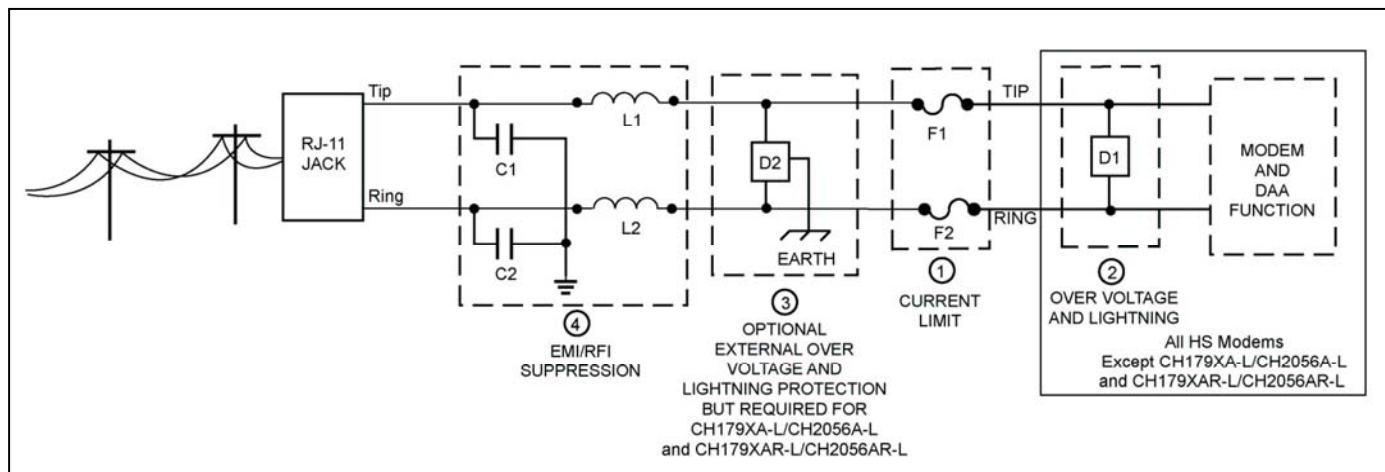

Figure 6. PSTN Line Interface for all HS Modems. CH179XA-L/CH2056A-L and CH179XAR-L/CH2056AR-L models do NOT contain internal Surge Protection (Dashed Box 2). The purchaser MUST provide external surge protection to maintain conveyed FCC Part 68 approval.

1. Current Limiting PSTN Protection Line Device.

Current limiting devices are mandatory to meet UL safety standards. To maintain conveyed FCC Part 68 approval, the current limiting components identified as F1 and F2 in dashed Box 1 must also survive FCC Part 68 surge testing. Refer to Cermetek Application Note #126, [Supplemental PSTN Line Protection](#), for more details. Refer to Application Note # 130, [Summary of Recommended Suppliers](#), for a list of suppliers and associated part numbers.

A resettable/repairable fuse (rated at 0.15 amps) is preferred because it resets automatically upon removal of the current flow. Non-resettable devices are also acceptable. Although CS-03 Part 1 (Canada) follows the requirements of FCC Part 68 (USA), Cermetek recommends contacting a certified independent lab to verify compliance in the specific application.

2. Over Voltage and Lightning Protection.

Surge Protection is provided by internal circuitry contained within all HS modems. No additional external components are required to maintain conveyed FCC Part 68 approval for all HS modems (excluding the CH179XA-L/CH2056A-L and CH179XAR-L/CH2056AR-L).

For CH179XA-L/CH2056A-L and CH179XAR-L/CH2056AR-L, the required surge protection (identified as D1 in dashed Box 2) must be supplied externally. The purchaser must include some form of surge protection as described herein to maintain conveyed FCC Part 68 approval. Refer to Application Note # 130 for a list of suppliers.

3. Optional External Over Voltage and Lightning Protection.

In most environments, the internal two terminal surge suppressor (see dashed Box 3) is adequate.

For severe environments, use an external three terminal device with an earth ground as is shown in dashed Box 3.

4. EMI/RFI Suppression.

Suppression of emitted EMI/RFI is recommended and is typically required to obtain FCC part 15 A and/or B approval. EMI/RFI suppression circuitry is also used to suppress reception of externally generated EMI/RFI signals, such as strong radio signals, should the CH1786A be located near a source of such signals. Although no external EMI/RFI noise suppression circuitry is required to maintain conveyed FCC Part 68 approval, additional suppression may be added as described below without adversely affecting FCC Part 68 approval.

A. To provide adequate EMI/RFI suppression, the capacitor/inductor network contained in dashed Box 5 should be located as close to the RJ-11C Jack as possible. Further, this network should be provided with an excellent ground path to the chassis.

B. Capacitors C1 and C2 should not exceed $0.005\mu\text{f}$. They must have a rating of 1.5KV and typically are $0.001\mu\text{f} \pm 20\%$. Inductors L1 and L2 may be either individual inductors or a dual inductor. Refer to Application Note #130 for a complete list of recommended vendors and associated part numbers. For UL applications, choose capacitors and inductors that are UL 60950 Edition 3 listed. The actual values of the components used may vary depending on the end product design and the nature of the EMI/RFI. Consult an FCC part 15 consultant if required.

Table 7A. HS Modem Electrical Specifications VCC = 5V ± 10%, Temp = 0°C to 70°F (unless otherwise stated).

| Symbol | Characteristic | Min. | Typ. | Max. | Units |
|--------------------------|---|------|------|---------|----------|
| V _{CC} | Positive Supply Voltage | 4.5 | 5.0 | 5.5 | V |
| I _{CC} Off Hook | Operating Current @ V _{CC} = 5.5V when modem is Off Hook | | 62 | | mA |
| I _{CC} On Hook | Operating Current @ V _{CC} = 5.5V when modem is On Hook | | 60 | | mA |
| I _{CCSL} | Power Current @ V _{CC} = 5.5V when modem is in Sleep Mode | | 22 | | mA |
| I _{CCZP} | Zero Power Current @ V _{CC} = 5.5V when modem is in Zero Power Mode ² | | 0.0 | | mA |
| I _{RIZP} | Current Supplied into RI pin when in Zero Power Mode @ V _{CC} = 5.5V ² | | 0.16 | | mA |
| V _{IH} | High Level Input Voltage ¹ | 2.0 | | | V |
| V _{IL} | Low Level Input Voltage ¹ | | | 0.8 | V |
| VT+ | Positive Hysteresis Threshold for RESET Pin | | 2.5 | | V |
| VT- | Negative Hysteresis Threshold for RESET Pin | | 0.5 | | V |
| V _{OH} | High Level Output (I _{OH} = 0.5 mA) ¹ | 2.4 | | | V |
| V _{OL} | Low Level Output (I _{OL} = 1.6 mA) ¹ | | | 0.6 | V |
| I _{IN} | Input Leakage Current ($\overline{\text{TXD}}$, $\overline{\text{DTR}}$, RTS) | | | 100 | μA |
| I _{OH} | Input Current ($\overline{\text{RST}}$) | | | 500 | μA |
| C _p | Capacitive Load ($\overline{\text{TXD}}$, $\overline{\text{DTR}}$, RTS) Capacitive Load (RST) | | | 10 8 | pF pF |

Table 7B. HS Modem Electrical Specifications VCC = 3.3V ± 10%, Temp = 0°C to 70°F (unless otherwise stated).

| Symbol | Characteristic | Min. | Typ. | Max. | Units |
|--------------------------|---|------|------|---------|----------|
| V _{CC} | Positive Supply Voltage | 3.0 | 3.3 | 3.6 | V |
| I _{CC} Off Hook | Operating Current @ V _{CC} = 3.6V when modem is Off Hook | | 52 | | mA |
| I _{CC} On Hook | Operating Current @ V _{CC} = 3.6V when modem is On Hook | | 50 | | mA |
| I _{CCSL} | Power Current @ V _{CC} = 3.6V when modem is in Sleep Mode | | 12 | | mA |
| I _{CCZP} | Zero Power Current @ V _{CC} = 3.6V when modem is in Zero Power Mode ² | | 0.0 | | mA |
| I _{RIZP} | Current Supplied into RI pin when in Zero Power Mode @ V _{CC} = 5.5V ² | | 0.16 | | mA |
| V _{IH} | High Level Input Voltage ¹ | 2.0 | | | V |
| V _{IL} | Low Level Input Voltage ¹ | | | 0.8 | V |
| VT+ | Positive Hysteresis Threshold for RESET Pin | | 2.5 | | V |
| VT- | Negative Hysteresis Threshold for RESET Pin | | 0.5 | | V |
| V _{OH} | High Level Output (I _{OH} = 0.5 mA) ¹ | 2.4 | | | V |
| V _{OL} | Low Level Output (I _{OL} = 1.6 mA) ¹ | | | 0.6 | V |
| I _{IN} | Input Leakage Current ($\overline{\text{TXD}}$, $\overline{\text{DTR}}$, RTS) | | | 100 | μA |
| I _{OH} | Input Current ($\overline{\text{RST}}$) | | | 500 | μA |
| C _p | Capacitive Load ($\overline{\text{TXD}}$, $\overline{\text{DTR}}$, RTS) Capacitive Load (RST) | | | 10 8 | pF pF |

NOTES for Table 7A & 7B

1. Output Load = 50 pF ± one TTL.
2. With recommended 30k ohm external resistor. Maximum resistor range: 10k to 100k ohm.

Table 8. HS Modem Electrical Specifications.

| Parameter | Min. | Typ. | Max. | Units | Comments |
|--------------------------------|------|------|------|-----------------|---|
| Off Hook Impedance | 20 | | | Ohm | |
| Trans Hybrid Loss | | 25 | | dB | 600 Ohm, RXA, TXA |
| Ring Voltage Loop | 110V | | 250V | V _{PP} | On 48VDC line voltage for sustained periods |
| Line Loop Current – (Off Hook) | | 20 | 100 | mA | Does not apply to CH1799A-L |
| Return loss @ 1000 Hz | | 15 | | dB | 600 Ohm |
| Ring Frequencies | | 40 | | Hz | |
| Receiver Insertion Gain | -0.5 | 0.0 | +0.5 | dB | |
| Transmit Power | | -9.5 | | dBm | 600 Ohm – Data Mode |
| First Character After Reset | 3.0 | | | sec | Delay |
| Inter Character Delay | 20 | 50 | | msec | Between all command characters |
| Command Delay | 100 | 200 | | msec | Between all AT command characters* |
| Minimum Reset Pulse Duration | 10 | | | msec | If user supplied |

Note: Must wait for modem response before issuing a new command.

Table 9. Analog Characteristics.

| Name | Type | Characteristic | Value |
|------|-------|-------------------------|----------------|
| SPK | O(DF) | Minimum Load | 300 Ohms |
| | | Maximum Capacitive Load | 0.01 μ f |
| | | Output Impedance | 10 Ohms |
| | | Output Voltage | 2.5 \pm 1.6V |
| | | D.C. Offset | <20mV |

Table 10. HS Modem Family Pin Functions.

| PACKAGE CONNECTION TABLE | | | |
|--------------------------|----------|---------|-------------------------|
| PIN NO. | FUNCTION | PIN NO. | FUNCTION |
| 1 | RING | 12 | NC |
| 2 | TIP | 13 | $\overline{\text{DTR}}$ |
| 3 | T1 | 14 | $\overline{\text{DSR}}$ |
| 4 | NC | 15 | $\overline{\text{RI}}$ |
| 5 | SPK | 16 | $\overline{\text{CTS}}$ |
| 6 | NC | 17 | $\overline{\text{DCD}}$ |
| 7 | NC | 18 | NC |
| 8 | NC | 19 | VCC |
| 9 | NC | 20 | GND |
| 10 | TXD | 21 | RST |
| 11 | RXD | 22 | $\overline{\text{RTS}}$ |

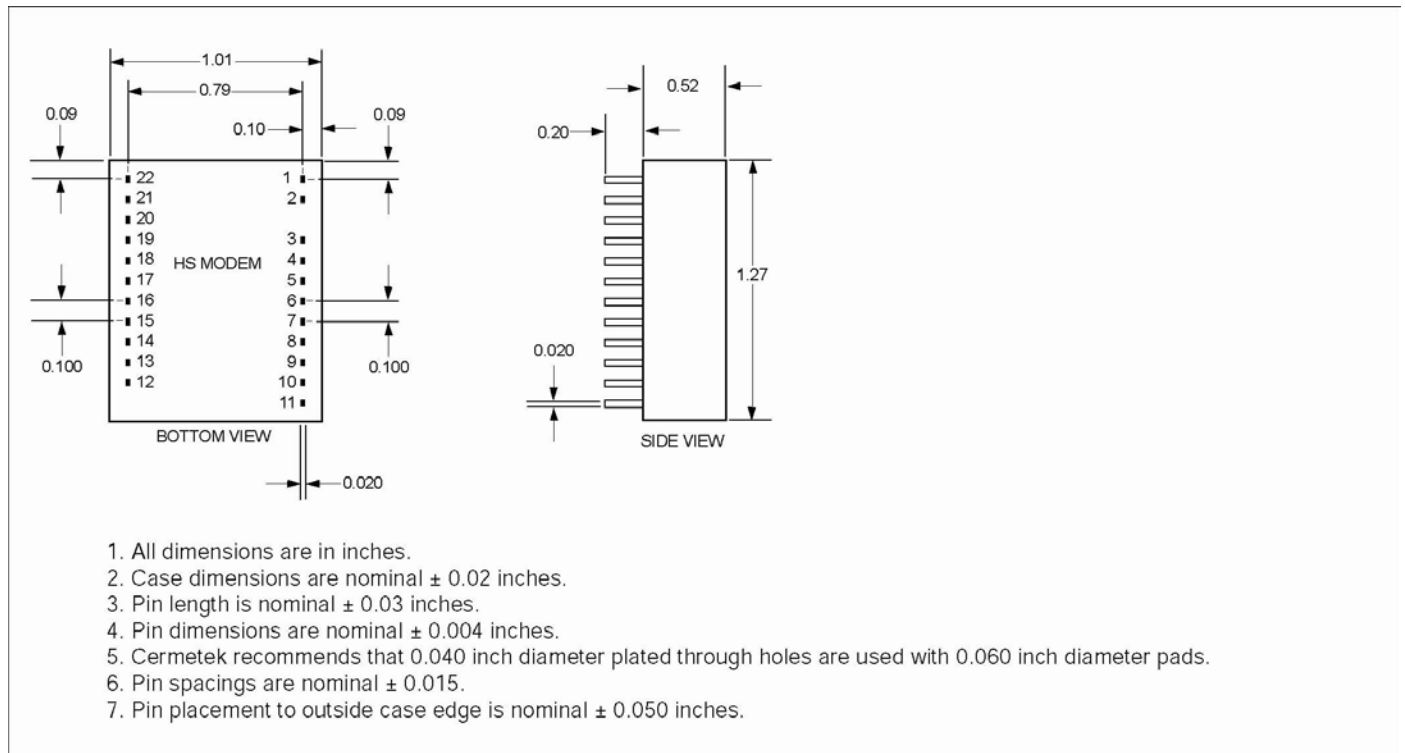

Figure 7A. HS Modem Family Physical Dimensions excluding those products described in Figure 7B.

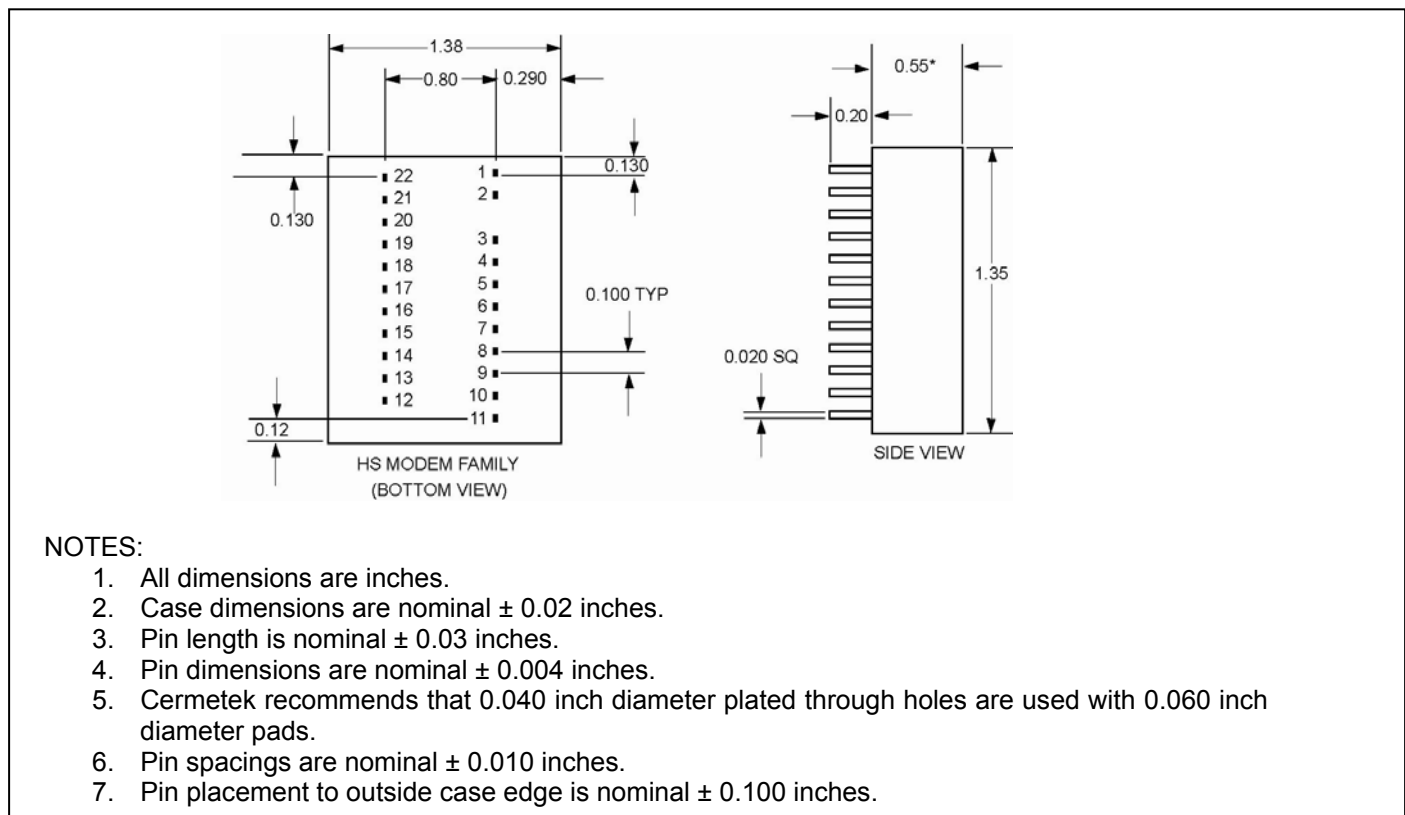

Figure 7B. Physical Dimensions ONLY for the CH179XA-B, CH2056A-B, CH179XA-L, CH2056A-L and CH179XAR-B, CH2056AR-B, CH179XAR-L, CH2056AR-L and extended temperature variations of listed products.

Table 11A. Summary of HS Family Non-RoHS Compliant Modem Products.

| Model | Summary of Features | Operating Temperature |
|---------------|--|------------------------------|
| CH1794A | Full Function, 14.4kbps, FCC Part 68 Approved, UL 60950 Listed | 0°C to + 70°C |
| CH1794A-B | Full Function, 14.4kbps, FCC Part 68 Approved, UL 60950 Listed, TBR21 Compliant | 0°C to + 70°C |
| CH1794A-C | Full Function with Caller ID (CID), 14.4kbps, FCC Part 68 Approved, UL 60950 Listed | 0°C to + 70°C |
| CH1794A-H | Full Function with Off-Hook Indication (OHI), 14.4kbps, FCC Part 68 Approved, UL 60950 Listed, Industry Canada Registered CS-03 Part I | 0°C to + 70°C |
| CH1794A-L | Full Function, 14.4kbps, FCC Part 68 Approved, UL 60950 Listed, No EEPROM, No Internal Surge Protection | 0°C to + 70°C |
| CH1794A-P | Full Function with Zero Power Down, 14.4kbps, FCC Part 68 Approved, UL 60950 Listed | 0°C to + 70°C |
| CH1794A-CP | Full Function with Caller ID (CID) and Zero Power Down, 14.4kbps, FCC Part 68 Approved, UL 60950 Listed | 0°C to + 70°C |
| CH1794A ET | Full Function, 14.4kbps, FCC Part 68 Approved, UL 60950 Listed | -40°C to +85°C |
| CH1794A ET-B | Full Function, 14.4kbps, FCC Part 68 Approved, UL 60950 Listed, TBR21 Compliant | -40°C to +85°C |
| CH1794A ET-C | Full Function with Caller ID (CID), 14.4kbps, FCC Part 68 Approved, UL 60950 Listed | -40°C to +85°C |
| CH1794A ET-H | Full Function with Off-Hook Indication (OHI), 14.4kbps, FCC Part 68 Approved, UL 60950 Listed, Industry Canada Registered CS-03 Part I | -40°C to + 85°C |
| CH1794A ET-P | Full Function with Zero Power Down, 14.4kbps, FCC Part 68 Approved, UL 60950 Listed | -40°C to +85°C |
| CH1794A ET-CP | Full Function with Caller ID (CID) and Zero Power Down, 14.4kbps, FCC Part 68 Approved, UL 60950 Listed | -40°C to +85°C |
| CH1799A | Full Function, 33.6kbps, FCC Part 68 Approved, UL 60950 Listed, Industry Canada Registered CS-03 Part I | 0°C to + 70°C |
| CH1799A-B | Full Function, 33.6kbps, FCC Part 68 Approved, UL 60950 Listed, TBR21 Compliant | 0°C to + 70°C |
| CH1799A-C | Full Function with Caller ID (CID), 33.6kbps, FCC Part 68 Approved, UL 60950 Listed, Industry Canada Registered CS-03 Part I | 0°C to + 70°C |
| CH1799A-H | Full Function with Off-Hook Indication (OHI), 33.6kbps, FCC Part 68 Approved, UL 60950 Listed, Industry Canada Registered CS-03 Part I | 0°C to + 70°C |
| CH1799A-L | Full Function, 33.6kbps, FCC Part 68 Approved, UL 60950 Listed, No EEPROM, No Internal Surge Protection | 0°C to + 70°C |
| CH1799A-P | Full Function with Zero Power Down, 33.6kbps, FCC Part 68 Approved, UL 60950 Listed, Industry Canada Registered CS-03 Part I | 0°C to + 70°C |
| CH1799A-CP | Full Function with Caller ID (CID) and Zero Power Down, 33.6kbps, FCC Part 68 Approved, UL 60950 Listed, Industry Canada Registered CS-03 Part I | 0°C to + 70°C |

Table 11A. Summary of HS Family Non-RoHS Compliant Modem Products (Continuation).

| Model | Summary of Features | Operating Temperature |
|---------------|--|------------------------------|
| CH1799A ET | Full Function, 33.6kbps, FCC Part 68 Approved, UL 60950 Listed | -40°C to +85°C |
| CH1799A ET-B | Full Function, 33.6kbps, FCC Part 68 Approved, UL 60950 Listed, TBR21 Compliant | -40°C to +85°C |
| CH1799A ET-C | Full Function with Caller ID (CID), 33.6kbps, FCC Part 68 Approved, UL 60950 Listed | -40°C to +85°C |
| CH1799A ET-H | Full Function with Off-Hook Indication (OHI), 33.6kbps, FCC Part 68 Approved, UL 60950 Listed, Industry Canada Registered CS-03 Part I | -40°C to + 85°C |
| CH1799A ET-P | Full Function with Zero Power Down, 33.6kbps, FCC Part 68 Approved, UL 60950 Listed | -40°C to +85°C |
| CH1799A ET-CP | Full Function with Caller ID (CID) and Zero Power Down, 33.6kbps, FCC Part 68 Approved, UL 60950 Listed | -40°C to +85°C |
| CH2056A | Full Function, 56.0kbps, FCC Part 68 Approved, UL 60950 Listed | 0°C to + 70°C |
| CH2056A-B | Full Function, 56.0kbps, FCC Part 68 Approved, UL 60950 Listed, TBR21 Compliant | 0°C to + 70°C |
| CH2056A-C | Full Function with Caller ID (CID), 56.0kbps, FCC Part 68 Approved, UL 60950 Listed | 0°C to + 70°C |
| CH2056A-H | Full Function with Off-Hook Indication (OHI), 56.0kbps, FCC Part 68 Approved, UL 60950 Listed, Industry Canada Registered CS-03 Part I | 0°C to + 70°C |
| CH2056A-L | Full Function, 56.0kbps, FCC Part 68 Approved, UL 60950 Listed, No EEPROM, No Internal Surge Protection | 0°C to + 70°C |
| CH2056A-P | Full Function with Zero Power Down, 56.0kbps, FCC Part 68 Approved, UL 60950 Listed | 0°C to + 70°C |
| CH2056A-CP | Full Function with Caller ID (CID) and Zero Power Down, 56.0kbps, FCC Part 68 Approved, UL 60950 Listed | 0°C to + 70°C |
| CH2056A ET | Full Function, 56.0kbps, FCC Part 68 Approved, UL 60950 Listed | -40°C to +85°C |
| CH2056A ET-B | Full Function, 56.0kbps, FCC Part 68 Approved, UL 60950 Listed, TBR21 Compliant | -40°C to +85°C |
| CH2056A ET-C | Full Function with Caller ID (CID), 56.0kbps, FCC Part 68 Approved, UL 60950 Listed | -40°C to +85°C |
| CH2056A ET-H | Full Function with Off-Hook Indication (OHI), 56.0kbps, FCC Part 68 Approved, UL 60950 Listed, Industry Canada Registered CS-03 Part I | -40°C to +85°C |
| CH2056A ET-P | Full Function with Zero Power Down, 56.0kbps, FCC Part 68 Approved, UL 60950 Listed | -40°C to +85°C |
| CH2056A ET-CP | Full Function with Caller ID (CID) and Zero Power Down, 56.0kbps, FCC Part 68 Approved, UL 60950 Listed | -40°C to +85°C |

Table 11B. Summary of HS Family RoHS Compliant Modem Products.

| Model | Summary of Features | Operating Temperature |
|----------------|--|------------------------------|
| CH1794AR | Full Function, 14.4kbps, FCC Part 68 Approved, UL 60950 Listed | 0°C to + 70°C |
| CH1794AR-B | Full Function, 14.4kbps, FCC Part 68 Approved, UL 60950 Listed, TBR21 Compliant | 0°C to + 70°C |
| CH1794AR-C | Full Function with Caller ID (CID), 14.4kbps, FCC Part 68 Approved, UL 60950 Listed | 0°C to + 70°C |
| CH1794AR-H | Full Function with Off-Hook Indication (OHI), 14.4kbps, FCC Part 68 Approved, UL 60950 Listed, Industry Canada Registered CS-03 Part I | 0°C to + 70°C |
| CH1794AR-L | Full Function, 14.4kbps, FCC Part 68 Approved, UL 60950 Listed, No EEPROM, No Internal Surge Protection | 0°C to + 70°C |
| CH1794AR-P | Full Function with Zero Power Down, 14.4kbps, FCC Part 68 Approved, UL 60950 Listed | 0°C to + 70°C |
| CH1794AR-CP | Full Function with Caller ID (CID) and Zero 0 Power Down, 14.4kbps, FCC Part 68 Approved, UL 60950 Listed | 0°C to + 70°C |
| CH1794AR ET | Full Function, 14.4kbps, FCC Part 68 Approved, UL 60950 Listed | -40°C to +85°C |
| CH1794AR ET-B | Full Function, 14.4kbps, FCC Part 68 Approved, UL 60950 Listed, TBR21 Compliant | -40°C to +85°C |
| CH1794AR ET-C | Full Function with Caller ID (CID), 14.4kbps, FCC Part 68 Approved, UL 60950 Listed | -40°C to +85°C |
| CH1794AR ET-H | Full Function with Off-Hook Indication (OHI), 14.4kbps, FCC Part 68 Approved, UL 60950 Listed, Industry Canada Registered CS-03 Part I | -40°C to +85°C |
| CH1794AR ET-P | Full Function with Zero Power Down, 14.4kbps, FCC Part 68 Approved, UL 60950 Listed | -40°C to +85°C |
| CH1794AR ET-CP | Full Function with Caller ID (CID) and Zero Power Down, 14.4kbps, FCC Part 68 Approved, UL 60950 Listed | -40°C to +85°C |
| CH1799AR | Full Function, 33.6kbps, FCC Part 68 Approved, UL 60950 Listed, Industry Canada Registered CS-03 Part I | 0°C to + 70°C |
| CH1799AR-B | Full Function, 33.6kbps, FCC Part 68 Approved, UL 60950 Listed, TBR21 Compliant | 0°C to + 70°C |
| CH1799AR-C | Full Function with Caller ID (CID), 33.6kbps, FCC Part 68 Approved, UL 60950 Listed, Industry Canada Registered CS-03 Part I | 0°C to + 70°C |
| CH1799AR-H | Full Function with Off-Hook Indication (OHI), 33.6kbps, FCC Part 68 Approved, UL 60950 Listed, Industry Canada Registered CS-03 Part I | 0°C to + 70°C |
| CH1799AR-L | Full Function, 33.6kbps, FCC Part 68 Approved, UL 60950 Listed, No EEPROM, No Internal Surge Protection | 0°C to + 70°C |
| CH1799AR-P | Full Function with Zero Power Down, 33.6kbps, FCC Part 68 Approved, UL 60950 Listed, Industry Canada Registered CS-03 Part I | 0°C to + 70°C |
| CH1799AR-CP | Full Function with Caller ID (CID) and Zero Power Down, 33.6kbps, FCC Part 68 Approved, UL 60950 Listed, Industry Canada Registered CS-03 Part I | 0°C to + 70°C |

Table 11B. Summary of HS Family RoHS Compliant Modem Products (Continuation).

| Model | Summary of Features | Operating Temperature |
|----------------|--|------------------------------|
| CH1799AR ET | Full Function, 33.6kbps, FCC Part 68 Approved, UL 60950 Listed | -40°C to +85°C |
| CH1799AR ET-B | Full Function, 33.6kbps, FCC Part 68 Approved, UL 60950 Listed, TBR21 Compliant | -40°C to +85°C |
| CH1799AR ET-C | Full Function with Caller ID (CID), 33.6kbps, FCC Part 68 Approved, UL 60950 Listed | -40°C to +85°C |
| CH1799AR ET-H | Full Function with Off-Hook Indication (OHI), 33.6kbps, FCC Part 68 Approved, UL 60950 Listed, Industry Canada Registered CS-03 Part I | -40°C to +85°C |
| CH1799AR ET-P | Full Function with Zero Power Down, 33.6kbps, FCC Part 68 Approved, UL 60950 Listed | -40°C to +85°C |
| CH1799AR ET-CP | Full Function with Caller ID (CID) and Zero Power Down, 33.6kbps, FCC Part 68 Approved, UL 60950 Listed | -40°C to +85°C |
| CH2056AR | Full Function, 56.0kbps, FCC Part 68 Approved, UL 60950 Listed | 0°C to + 70°C |
| CH2056AR-B | Full Function, 56.0kbps, FCC Part 68 Approved, UL 60950 Listed, TBR21 Compliant | 0°C to + 70°C |
| CH2056AR-C | Full Function with Caller ID (CID), 56.0kbps, FCC Part 68 Approved, UL 60950 Listed | 0°C to + 70°C |
| CH2056AR-H | Full Function with Off-Hook Indication (OHI), 56.0kbps, FCC Part 68 Approved, UL 60950 Listed, Industry Canada Registered CS-03 Part I | 0°C to + 70°C |
| CH2056AR-L | Full Function, 56.0kbps, FCC Part 68 Approved, UL 60950 Listed, No EEPROM, No Internal Surge Protection | 0°C to + 70°C |
| CH2056AR-P | Full Function with 0 Power Down, 56.0kbps, FCC Part 68 Approved, UL 60950 Listed | 0°C to + 70°C |
| CH2056AR-CP | Full Function with Caller ID (CID) and Zero Power Down, 56.0kbps, FCC Part 68 Approved, UL 60950 Listed | 0°C to + 70°C |
| CH2056AR ET | Full Function, 56.0kbps, FCC Part 68 Approved, UL 60950 Listed | -40°C to +85°C |
| CH2056AR ET-B | Full Function, 56.0kbps, FCC Part 68 Approved, UL 60950 Listed, TBR21 Compliant | -40°C to +85°C |
| CH2056AR ET-C | Full Function with Caller ID (CID), 56.0kbps, FCC Part 68 Approved, UL 60950 Listed | -40°C to +85°C |
| CH2056AR ET-H | Full Function with Off-Hook Indication (OHI), 56.0kbps, FCC Part 68 Approved, UL 60950 Listed, Industry Canada Registered CS-03 Part I | -40°C to +85°C |
| CH2056AR ET-P | Full Function with Zero Power Down, 56.0kbps, FCC Part 68 Approved, UL 60950 Listed | -40°C to +85°C |
| CH2056AR ET-CP | Full Function with Caller ID (CID) and Zero Power Down, 56.0kbps, FCC Part 68 Approved, UL 60950 Listed | -40°C to +85°C |

Table 11A and 11B Notes:

- 1. All products are available in VCC=3.3V versions. Specify 3.3V operation when ordering.**
- 2. All features listed can be provided in virtually any combination required to meet a specific application. If a particular combination of features does not explicitly appear in Table 11a or 11B, contact the factory for ordering instructions and delivery.**

Cermetek reserves the right to make changes in specifications at any time and without notice. The information furnished by Cermetek in this publication is believed to be accurate and reliable. However, Cermetek assumes no responsibility for its use, or for any infringements of patents or other rights of third parties resulting from its use. No license is granted under any patents or patent rights of Cermetek.

Cermetek provides the user with a FCC (USA) and IC (Canada) Approved or Approvable device. However, Cermetek does not have influence over nor knowledge of the specific user application environment. Therefore, for FCC and IC Approved or Approvable devices, the user assumes all risk for maintaining compliance to registration.

Printed in U.S.A