

# RoHS Compliant XFP Optical Transceiver

## —850 nm for up to 300m Reach

### PLRXXL Series



#### Key Features

- 850 nm optical signals for up to 300 m reach over enhanced multimode fiber
- Low power consumption (< 1.5 W max)
- 0°C to 70°C case temperature operating range
- 9.95 Gb/s to 10.75 Gb/s serial optical and electrical interface
- Durable plastic bail delatch mechanism
- LC receptacle optical connector
- Bit error rate <  $1 \times 10^{-12}$
- Excellent EMI performance
- High reliability
- Requires only 3.3 V and 1.8 V power supplies
- Digital Diagnostic Monitoring support
- XFI AC-coupled electrical interface
- Support both line and XFI system loopback

#### Applications

- Local Area Network (LAN)
- Storage Area Network (SAN)
- 10 Gigabit Ethernet 10GBASE-SR and 10GBASE-SW applications
- 10G Fibre Channel optical interconnects
- Ethernet switches and applications
- Fibre Channel switches and applications

#### Compliance

- Compliant with XFP MSA INF8077i Rev. 4.5
- RoHS6/6 compliant
- IEEE802.3 2005 Clause 52 standard
- 10 GFC 1200-MX-SN-I standard
- Class 1 Laser Safety
- Tested in accordance with Telcordia GR-468 standard

The JDSU 10 Gb/s 850 nm XFP optical transceiver is a cost-effective, fully duplex, high-reliability optoelectronic (O/E) transceiver that transmits and receives standard compliant high-speed serial 10 Gb/s optical and electrical signals. The JDSU 10 Gb/s XFP optical transceiver provides a single product solution for the IEEE802.3 2005 Clause 52 10GBASE-SR, 10GBASE-SW, and 10GFC optical interconnects that are used in Telecommunication, Data Communication, and Storage Area Network applications. The module complies with the 10 Gigabit Small Form Factor Pluggable (XFP) Multi-Source Agreement (MSA).

The RoHS6/6 compliant XFP optical transceiver features a JDSU 850 nm Vertical Cavity Surface Emitting Laser (VCSEL) and a PIN photodiode. The XFI electrical interface uses 10 Gb/s differential data channels for communications to the module as specified in the 10 Gigabit Small Form Factor Pluggable (XFP) Multi-Source Agreement (MSA). The transceiver's MSA compliant "hot-z-pluggable" mechanical design provides the system designer a small footprint 10 Gb/s solution and enables high density front-panel designs with up to 16 10G ports per line card. The JDSU 10 Gb/s XFP optical transceiver is a 850 nm wavelength optical transceiver targeted at short reach applications. Link lengths greater than 300 m can be achieved on 2000 MHz·km multimode fiber.

## Section 1 Functional Description

The JDSU 10 Gb/s 850 nm XFP optical transceiver is a fully duplex serial electric, serial optical device with both transmit and receive functions contained in a single module. It is designed to be compliant with IEEE802.3 2005 Clause 52 10GBASE-SR, 10GBASE-SW, and 10 G Fibre Channel specifications. The transceiver is also fully compliant with the 10 Gigabit Small Form Factor XFP Pluggable Module Multi-Source Agreement INF8077i Rev. 4.5. This device is the ideal solution for high density, cost effective 10 Gb/s 850 nm multimode-mode fiber (MMF) interconnects. A block diagram of the JDSU 10 Gb/s 850 nm XFP optical transceiver is shown in Figure 1 below.

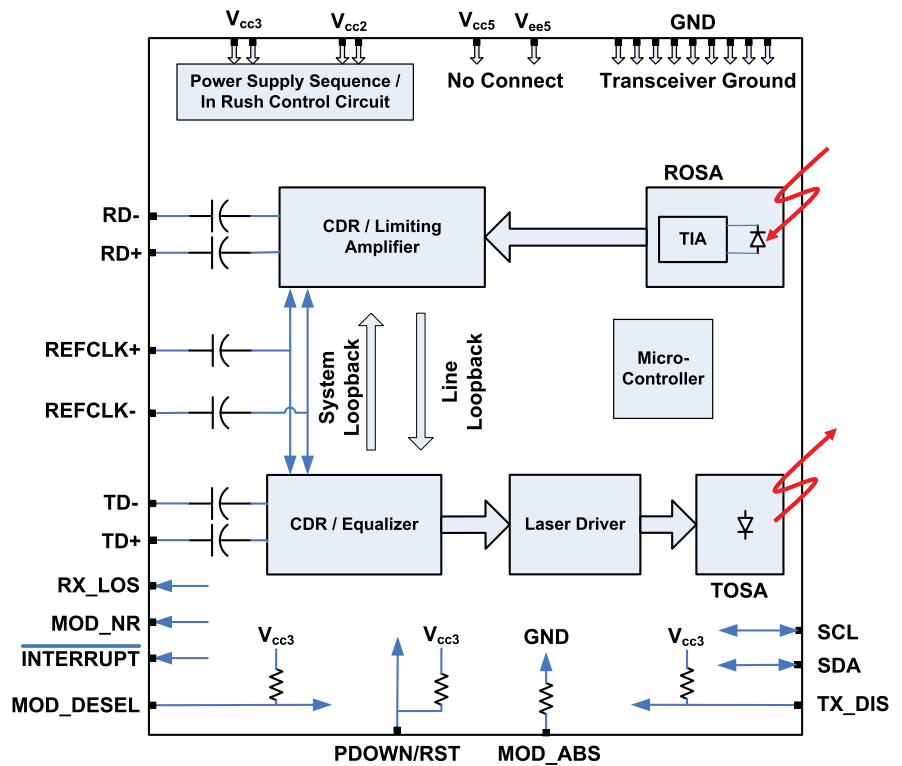

Figure 1 JDSU 10 Gb/s 850 nm XFP optical transceiver functional block diagram

The JDSU 10 Gb/s 850 nm XFP optical transceiver has several low-speed interface connections including a 2-wire serial interface. These connections include; module not ready (Mod\_NR), module deselect (Mod\_DeSel), Interrupt, transmitter disable (TX\_DIS), module absent (Mod\_ABS), Receive Loss Of Signal (RX\_LOS), and power down/reset (P\_Down/RST).

Two loopback modes are available through the two-wire serial interface. The loopback modes are useful to facilitate stand-alone testing. In system loopback mode, data recovered from the system side transmit interface is re-directed to the system side receive interface. This facilitates system side test and debug. In network loopback mode, data recovered from the line side receive interface (optics) is looped to the line side transmitter output back to the fiber.

### Transmitter

The transmitter path converts 9.95 Gb/s, 10.3 Gb/s, 10.5 Gb/s, or 10.75 Gb/s NRZ electrical data to a standard compliant optical signal. The transmitter accepts a 100  $\Omega$  differential 120 mV peak-to-peak to 1000 mV peak-to-peak 10 Gb/s CML electrical signal on TD- and TD+ pins. This performance exceeds the XFI “Ziffy” specification in the XFP MSA INF8077i revision 4.5 and provides over 300 mm (12 inches) reach on improved FR4 material (loss tangent of 0.016) and offers greater flexibility to system integrators for host board layout.

Inside the module, the differential signals pass through a signal conditioner with equalization that compensates for losses and deterministic jitter present on the input data stream. A reference clock input (RefCLK+, RefCLK-) is used by the internal PLL to determine line rate and signal lock condition. The Tx clock circuit provides a lock alarm output, failure to lock results in Mod\_NR asserted. The output of the Tx signal conditioner is input to the laser driver circuit which transforms the small swing digital voltage to an output modulation and bias current that drives a directly modulated 850 nm VCSEL. The optical signal is engineered to meet the IEEE802.3 2005 Clause 52 10GBASE-SR, 10GBASE-SW, and 10 GFC specifications. Closed-loop control of the transmitted laser power over temperature and voltage variations is provided. An LC connectorized receptacle provides the mechanical interface to the multi-mode fiber plant.

### Receiver

The receiver converts incoming DC balanced serial 9.95 Gb/s, 10.3 Gb/s, 10.5 Gb/s, or 10.75 Gb/s NRZ optical data into serial XFI electrical data. An LC connectorized receptacle provides the mechanical interface to the multi-mode fiber plant. A high speed PIN photodiode converts the optical signal into a current which is converted to a voltage in a high-gain transimpedance amplifier. The amplified signal is passed to a signal conditioning IC that provides clock and data recovery. Loss of signal, and signal lock detection is included in the receive circuitry that is reflected in the Mod\_NR status pin. The recovered data is output on the RD+ and RD- pins as a 100  $\Omega$  250 mV peak-to-peak CML signal. The output signal meets the XFP MSA requirements.

## Low Speed Signaling

Low speed signaling is based on low voltage TTL (LVTTL) operating at a nominal voltage of 3.3 V.

SCL/SDA: Two wire Serial interface clock and data line. Hosts should use a pull-up resistor connected to Vcc 3.3 V on the two-wire interface SCL (clock), SDA (data), and all low speed outputs.

Mod\_NR: Output pin. When asserted high indicates that the module has detected a condition that renders Tx and or Rx data invalid.

Mod\_DeSel: Input pin. When held low by the host the module responds to 2-wire serial communication commands. When high the module does not respond to or acknowledge any 2-wire interface communication from the host.

$\overline{\text{Interrupt}}$ : Output pin. When low indicates possible module operational fault or a status critical to the host system.

TX\_DIS: Input pin. When asserted high the transmitter output is turned off.

Mod\_ABS: Output pin. Asserted high when the XFP module is absent and is pulled low when the XFP module is inserted.

RX\_LOS: Output pin. Asserted high when insufficient optical power for reliable signal reception is received.

P\_Down/RST: Multifunction input pin. The module uses less than 1.5W and therefore is always compliant to the power down specification. The module is fully functional when P\_Down is asserted high. Reset can be initiated by pulling this pin high and then low. The reset pulse is generated on the falling edge of the P-Down signal. Following reset, the internal PLL's must reacquire lock and will temporarily indicate a Mod\_NR failure until the PLL's reacquire lock.

## Section 2 Application Schematics

Recommended MSA connections to the JDSU 10 Gb/s 850 nm XFP optical transceiver are shown in Figure 2 below.

Power supply filtering is recommended for the JDSU 10 Gb/s 850 nm XFP optical transceiver. To limit wide band noise power, the host system and module shall each meet a maximum of 2% peak-to-peak noise when measured with a 1 MHz low pass filter. In addition, the host system and the module shall each meet a maximum of 3% peak-to-peak noise when measured with a filter from 1 MHz - 10 MHz.

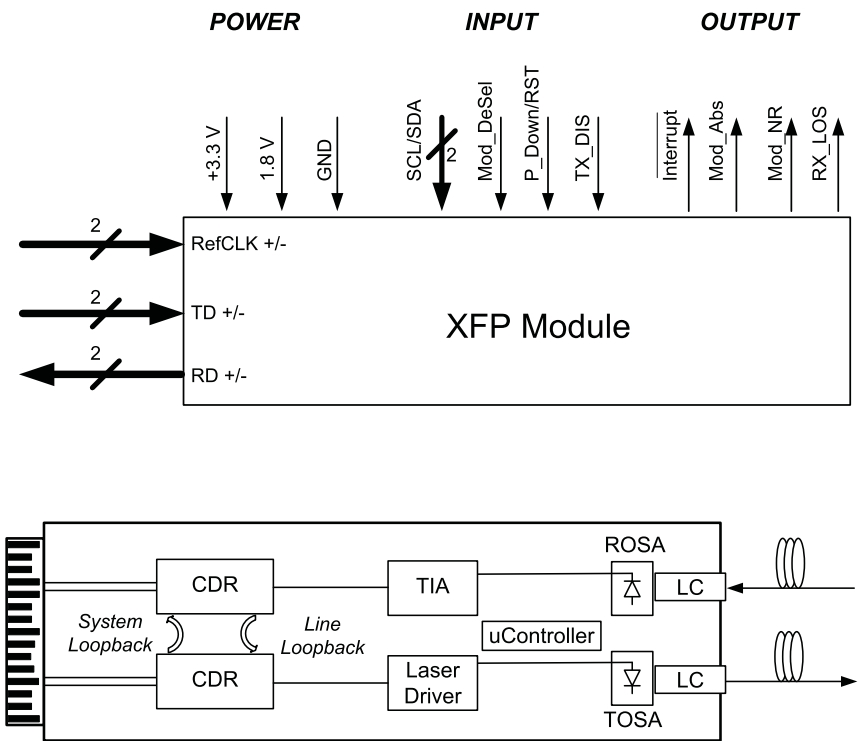

Figure 2 Application schematics for the JDSU 10 Gb/s 850 nm XFP optical transceiver

## Section 3 Specifications

Technical specifications related to the JDSU 10 Gb/s 850 nm XFP optical transceiver includes:

- Section 3.1 Pin Function Definitions
- Section 3.2 XFP/XFI Reference Model Compliance Points
- Section 3.3 Absolute Maximum Ratings
- Section 3.4 Electrical Characteristics
- Section 3.5 Jitter Specifications
- Section 3.6 Input Reference Clock Specifications
- Section 3.7 Timing Requirement of Control and Status I/O
- Section 3.8 XFP 2-wire Interface Protocol and Management Interface
- Section 3.9 Optical Characteristics
- Section 3.10 Optical Link Distances
- Section 3.11 Regulatory Compliance
- Section 3.12 PCB Layout
- Section 3.13 Module Outline
- Section 3.14 Connectors

### 3.1 Pin Function Definitions

The transceiver pin descriptions as defined in SFF-8431 are shown in Figure 3 below.

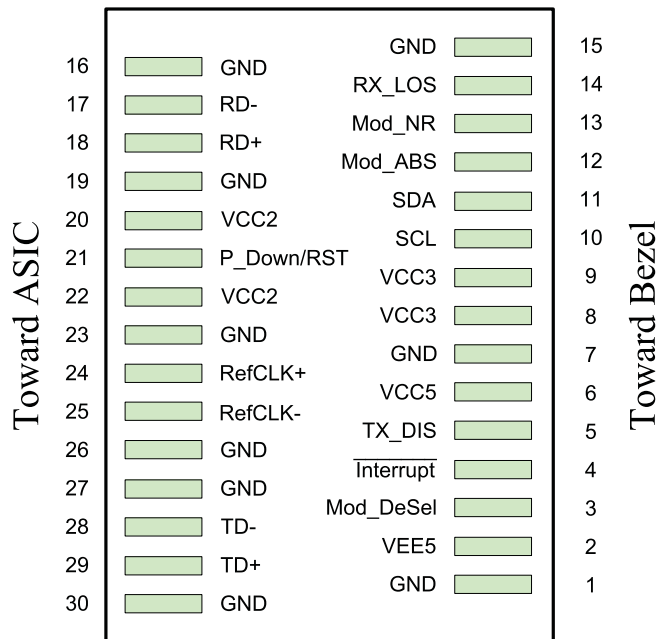

Figure 3 XFP optical transceiver pin-out on host board

7

Table 1 XFP optical transceiver pin descriptions

Pin Number	Symbol	Name	Description
1		GND <sup>1</sup>	Module Ground
2		VEE5	Not Used; may be left unconnected (Optional -5.2 V Power Supply)
3	LVTTTL-I	Mod_Desel	Module De-select; When held low allows the module to respond to 2-wire serial interface commands
4	LVTTTL-O	Interrupt <sup>2</sup>	Interrupt; Indicates presence of an important condition which can be read over the serial 2-wire interface
5	LVTTTL-I	TX_DIS	Transmitter Disable; Transmitter Laser Source Turned Off
6		VCC5	+5 V Power Supply (not used)
7		GND <sup>1</sup>	Module Ground
8		VCC3	+3.3 V Power Supply
9		VCC3	+3.3 V Power Supply
10	LVTTTL-I	SCL <sup>2</sup>	Two Wire Interface Clock
11	LVTTTL-I/O	SDA <sup>2</sup>	Two Wire Interface Data Line
12	LVTTTL-O	Mod_Abs <sup>2</sup>	Indicates Module is not present. Grounded in the Module
13	LVTTTL-O	Mod_NR <sup>2</sup>	Module Not Ready; Indicating Module Operational Fault
14	LVTTTL-O	RX_LOS <sup>2</sup>	Receiver Loss Of Signal Indicator
15		GND <sup>1</sup>	Module Ground
16		GND <sup>1</sup>	Module Ground
17	CML-O	RD-	Receiver Inverted Data Output
18	CML-O	RD+	Receiver Non-Inverted Data Output
19		GND <sup>1</sup>	Module Ground
20		VCC2	+1.8 V Power Supply.
21	LVTTTL-I	P_Down/RST	Power down; When high, the module limits power consumption to 1.5 W or below. Serial interface is functional in the low power mode. Reset; The falling edge initiates a complete reset of the module including the serial interface, equivalent to a power cycle.
22		VCC2	+1.8 V Power Supply
23		GND <sup>1</sup>	Module Ground
24	PECL-I	RefCLK+	Reference Clock Non-Inverted Input, AC coupled on the host board
25	PECL-I	RefCLK-	Reference Clock Inverted Input, AC coupled on the host board
26		GND <sup>1</sup>	Module Ground
27		GND <sup>1</sup>	Module Ground
28	CML-I	TD-	Transmitter Inverted Data Input
29	CML-I	TD+	Transmitter Non-Inverted Data Input
30		GND <sup>1</sup>	Module Ground

1. Module ground pins (GND) are isolated from the module case and chassis ground within the module

2. Shall be pulled up with 4.7 kΩ – 10 kΩ to a voltage between 3.15 V and 3.45 V on the host board

# 8

## 3.2 XFP/XFI Reference Model Compliance Points

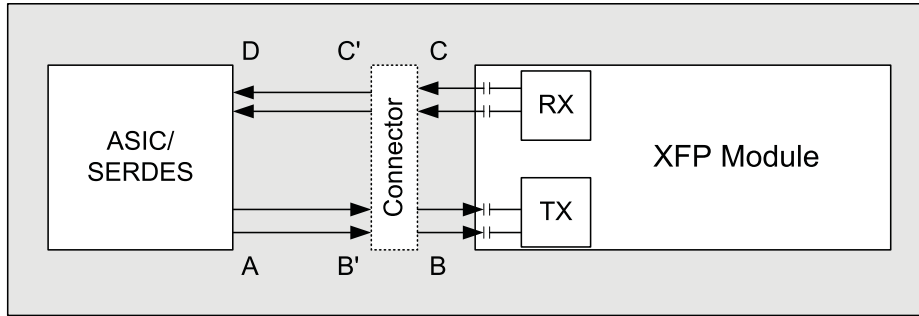

Figure 4 XFP optical transceiver model compliance points

## 3.3 Absolute Maximum Ratings

Parameter	Symbol	Ratings	Unit
Storage temperature	$T_{ST}$	-40 to +100	°C
Operating case temperature	$T_{OP}$	-40 to 80 (temporary excursions)	°C
Relative humidity	RH	5 to 95 (non-condensing)	%
Power supply voltage	$V_{CC2, max}$	-0.5 to 2.3	V
	$V_{CC3, max}$	-0.5 to 3.8	V

Note: Absolute maximum ratings represent the damage threshold of the device. Damage may occur if the device is operated above the limits stated here except for brief excursions. Performance is not guaranteed and reliability is not implied for operation at any condition outside the recommended operating limits.



## 9

### 3.4 Electrical Characteristics

(Top = 0°C - 70°C case, unless otherwise stated)

Parameter	Symbol	Min.	Typ.	Max.	Unit	Notes
<b>Supply Currents and Voltages</b>						
Voltage3	V <sub>cc3</sub>	3.13	3.3	3.47	V	With respect to GND
Voltage5	V <sub>cc5</sub>		5		V	Not used, no internal connection
Voltage2	V <sub>cc2</sub>	1.71	1.8	1.89		VPS
Supply current3	I <sub>cc3</sub>		350	420	mA	
Supply current5	I <sub>cc5</sub>		0		mA	
Supply current2	I <sub>cc2</sub>		10	15	mA	VPS
Power dissipation	P <sub>wr</sub>		1.2	1.5	W	
<b>Low speed control and sense signals (detailed specification in XFP MSA INF8077i Rev. 4.5)</b>						
Outputs (Interrupt, Mod_NR, RX_LOS)	V <sub>OL</sub>	0		0.4	V	R <sub>pullup</sub> pulled to host_Vcc, Mod_NR, measured at host side of connector. I <sub>OL</sub> (max)=3mA
	V <sub>OH</sub>	host_Vcc-0.5		host_Vcc+ 0.3	V	R <sub>pullup</sub> pulled to host_Vcc, measured at host side of connector
Inputs (TX_DIS, P_Down/RST, M_DSEL)	V <sub>IL</sub>	-0.3		0.8	V	Pulled up in module to Vcc3
	V <sub>IH</sub>	2		Vcc3+ 0.3	V	Pulled up in module to Vcc3
Loss of signal voltage level	V <sub>OH</sub>	V <sub>cc</sub> -0.5		V <sub>cc</sub>	V	LOS output level V <sub>OL</sub> T <sub>LOSD</sub> after light input > LOSD <sup>2</sup>
	V <sub>OL</sub>	0		0.5	V	LOS output level V <sub>OH</sub> T <sub>LOSA</sub> after light input < LOSA <sup>2</sup>
SCL and SDA inputs	V <sub>IL</sub>	-0.3		Vcc3*0.3		R <sub>pullup</sub> pulled to host_Vcc, measured at XFP side of connector
	V <sub>IH</sub>	Vcc3*0.7		Vcc3+0.5		R <sub>pullup</sub> pulled to host_Vcc, measured at XFP side of connector
<b>Transmitter Input (detailed specification in XFP MSA INF8077i Rev. 4.5)</b>						
Data input Baud rate nominal		9.95	10.3125	10.75	GBd	
Data input bit rate tolerance		-100		+100	ppm	
Data input compliance			B			Internally AC coupled signals
Data input differential impedance	R <sub>i</sub>	80	100	120	Ω	
<b>Receiver Output (detailed specification in XFP MSA INF8077i Rev. 4.5)</b>						
Data output Baud rate nominal		9.95	10.3125	10.75	GBd	
Data output compliance			C			Internally AC coupled signals
Data output bit rate stability		-100		+100	ppm	

# 10

## 3.5 Jitter Specifications

Parameter	Symbol	Min	Max	Unit	Notes
<b>Transmitter electrical input jitter from host at B (detailed specification in XFP MSA INF8077i Rev. 4.5)</b>					
Total non-EQJ jitter			0.41	UI(p-p)	Total jitter less ISI
Total jitter	TJ		0.61	UI(p-p)	
Eye mask	X1		0.305	UI	Mask coordinate X1=0.205 if total non-DDJ is measured
Eye mask	Y1	60		mV	
Eye mask	Y2		410	mV	50 mV is allocated for multiple reflections
<b>Receiver electrical output jitter to host at C (detailed specification in XFP MSA INF8077i Rev. 4.5)</b>					
Deterministic jitter	DJ		0.18	UI(p-p)	Includes jitter transferred from the optical receiver during any valid operational input condition.
Total jitter	TJ		0.34	UI(p-p)	Includes jitter transferred from the optical receiver during any valid operational input condition.
Eye mask	X1		0.17	UI	
Eye mask	X2		0.42	UI	
Eye mask	Y1	170		mV	
Eye mask	Y2		425	mV	
<b>Datcom module transmitter and receiver (detailed specification in XFP MSA INF8077i Rev. 4.5)</b>					
Meets the requirements of IEEE802.3 2005 Clause 52 and 10GFC					
Jitter transfer bandwidth	BW		8	MHz	PRBS 2 <sup>31</sup> -1, Data or scrambled 64B/66B as detailed in IEEE802.3 2005 Clause 52
Jitter peaking			1	dB	Frequency >120 KHz

## 3.6 Input Reference Clock Specifications

Parameter	Symbol	Min.	Typ.	Max.	Unit	Notes
Clock differential input impedance	Zd	80	100	120	Ω	
Differential input clock amplitude		640		1600	mV	AC coupled PECL
Reference clock duty cycle		40		60	%	
Reference clock rise/fall time	Tr/Tf	200		1250	ps	20%-80%
Reference clock frequency	f <sub>0</sub>		Baud/64		MHz	
RMS random jitter	σ			10	ps	up to 100 MHz
Reference clock frequency tolerance	Δf	-100		100	ppm	

### 3.7 Timing Requirement of Control and Status I/O

Parameter	Symbol	Min	Max	Unit	Notes
TX_DIS assert time	t_off		10	μsec	Rising edge of TX_DIS to fall of output signal below 10% of nominal
TX_DIS negate time	t_on		2	msec	Falling edge of TX_DIS to rise of output signal above 90% of nominal
Time to initialize	t_init		300	msec	From power on or from falling edge of P_Down/RST
Interrupt assert delay	Interrupt_on		200	msec	From occurrence of the condition triggering interrupt
Interrupt negate delay	Interrupt_off		500	μsec	From clear on read Interrupt flags
P_Down/RST assert delay	P_Down/RST_on		100	μsec	From power down initiation
Mod_NR assert delay	Mod_NR_on		1	msec	From occurrence of fault to assertion of Mod_NR
Mod_NR negate delay	Mod_NR_off		1	msec	From clearance of signal to negation of Mod_NR
P-Down reset time		10		μsec	Minimum time of P-Down assert to initiate reset
RX_LOS assert delay	t_loss_on		100	μsec	From occurrence of loss of signal to assertion of RX_LOS
RX_LOS negate delay	t_loss_off		100	μsec	From occurrence of return of signal to negation of RX_LOS

Note: 2-wire serial bus timing is described in Chapter 4 of XFP MSA INF8077i Rev. 4.5

### 3.8 XFP 2-wire interface protocol and Management Interface

The JDSU 10 Gb/s 850 nm XFP optical transceiver incorporates a XFP compliant 2-wire management interface which is used for serial ID, digital diagnostics, and certain control functions. It is modeled on the SFF-8472 Rev 9.3 specification modified to accommodate a single 2-wire interface address. In addition to the basic I2C read/write functionality the modules support packet error checking that, when enabled, allows the host system to confirm the validity of any read data. Details of the protocol and interface are explicitly described in the MSA. Please refer to the MSA for design reference.

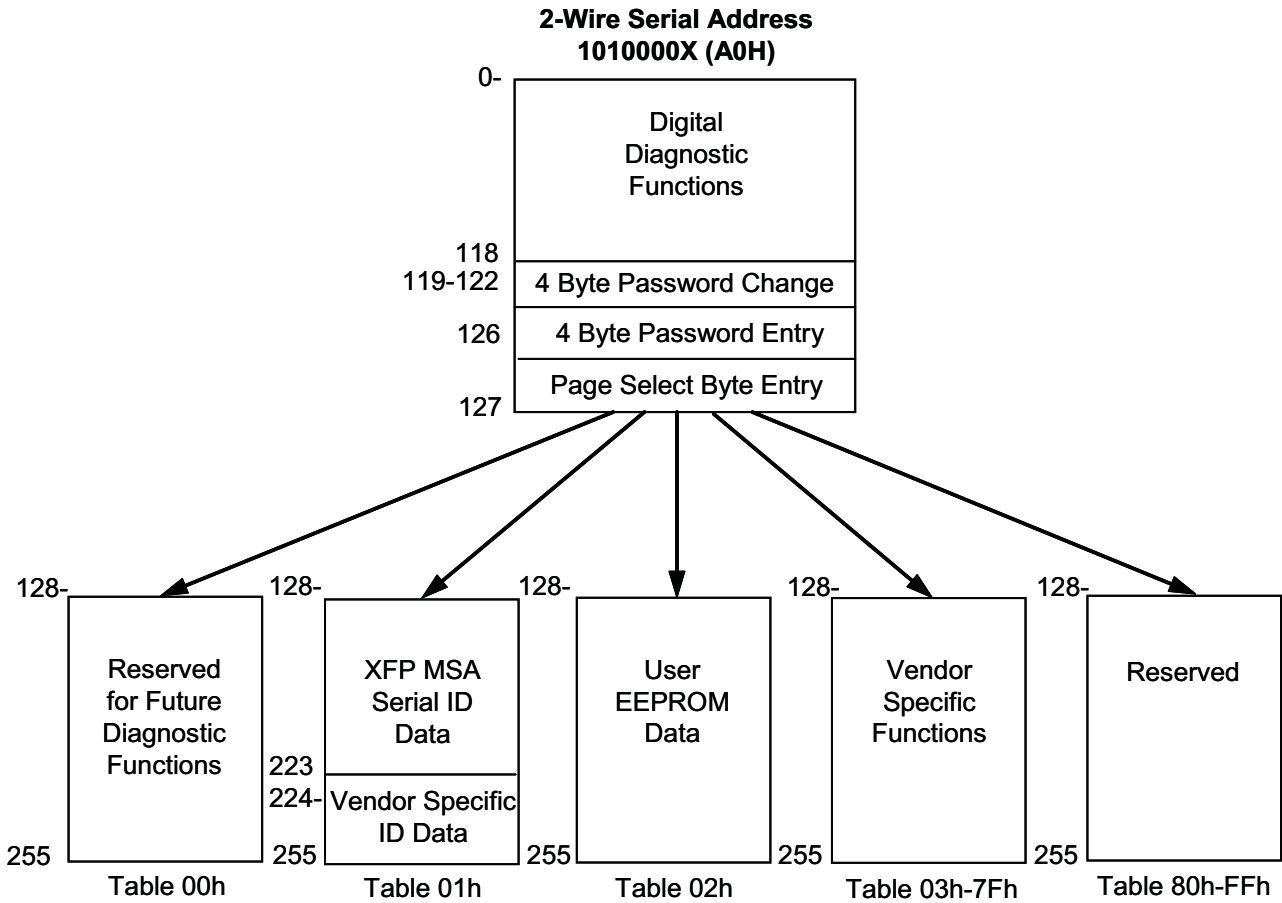

Figure 5 XFP 2-wire serial digital diagnostic memory map

# 13

## 3.9 Optical Characteristics

(Top = 0°C - 70°C case, unless otherwise stated)

Parameter <sup>1</sup>	Symbol	Min.	Typ.	Max.	Unit
<b>Transmitter</b>					
Signal speed		9.95	10.3125	10.75	Gb/s
Signal tolerance				±100	ppm
Average optical power	P <sub>Avg</sub>	-6.5	-2.8	-1.0	dBm
Extinction ratio	ER	3	6		dB
Triple trade off curve compliance					
OMA (Optical modulation amplitude) <sup>2</sup>	OMA	380	600	1200	μW
RMS spectral width <sup>2</sup>	Δλ		0.25	0.45	nm
Center wavelength <sup>2</sup>	λ <sub>p</sub>	840	850	860	nm
Relative intensity noise	RIN <sub>12</sub> OMA			-128	dB/Hz
Transmitter and dispersion penalty	TDP			3.9	dB
Return loss tolerance				12	dB
<b>Receiver</b>					
Signal speed		9.95	10.3125	10.75	GBd
Wavelength	λ <sub>p</sub>	840		860	nm
Return reflectance				-12	dB
Average receive power				-1	dBm
Stressed Rx sensitivity OMA	SRS			-7.5	dBm
Bit error ratio <sup>3</sup>	BER			10 <sup>-12</sup>	

1. See IEEE802.3 2005 Clause 52 Media Access Control (MAC) Parameters, Physical Layer, and Management Parameters for 10 Gb/s Operation for complete specification
2. Triple trade off curves define OMA, Spectral Width and Center Wavelength (any two parameters fix the third)
3. Without FEC
4. System level performance is dependent on system design, airflow, inlet conditions, and power consumptions to achieve 70°C case temperature.

## 3.10 Optical Link Distances

Data Rate	Fiber Type	Modal Bandwidth @ 850nm (MHz-km)	Worst Case Distance Range Specified (m)	Typical Range (m)
9.95-10.3125 Gb/s	62.5/125 μm MMF	160	2 - 26	
	62.5/125 μm MMF	200	2 - 33	
	50/125 μm MMF	400	2 - 66	
	50/125 μm MMF	500	2 - 82	
	50/125 μm MMF	2000	2 - 300	> 400

### 3.11 Regulatory compliance

The JDSU 10 Gb/s 850 nm XFP optical transceiver is lead-free and RoHS 6/6 compliant per Directive 2002/95/EC of the European Parliament and of the Council of 27 January 2003 on the restriction of the use of certain hazardous substances in electrical and electronic equipment.

The JDSU 10 Gb/s 850 nm XFP optical transceiver complies with international Electromagnetic Compatibility (EMC) and international safety requirements and standards. EMC performance is dependent on the overall system design. Information included herein is intended as a figure of merit for designers to use as a basis for design decisions.

**Table 2 Regulatory compliance**

Feature	Test Method	Performance
Component safety	UL 60950 UL94-V0 IEC 60950	UL File E209897  TUV Report/Certificate (CB scheme)
RoHS compliance	Directive 2002/95/EC	Compliant per the Directive 2002/95/EC of the European Parliament and of the Council of 27 January 2003 on the restriction of the use of certain hazardous substances in electrical and electronic equipment
Laser eye safety	EN 60825 U.S. 21CFR 1040.10	TUV Certificate CDRH compliant and Class 1 laser eye safe
<b>Electromagnetic Compatibility</b>		
Electromagnetic emissions	EMC Directive 89/336/EEC FCC CFR47 Part 15 IEC/CISPR 22 AS/NZS CISPR22 EN 55022 ICES-003, Issue 4 VCCI-03	Noise frequency range: 30 MHz to 40 GHz. Good system EMI design practice required to achieve Class B margins.
Electromagnetic immunity	EMC Directive 89/336/EEC IEC /CISPR/24 EN 55024	
ESD immunity	EN 61000-4-2	Exceeds requirements. Withstand discharges of; 8kV contact, 25kV air
Radiated immunity	EN 61000-4-3	Exceeds requirements. Field strength of 10 V/m RMS, from 10 MHz to 1 GHz. No effect on transmitter / receiver performance is detectable between these limits.

### 3.12 PCB Layout

Recommended PCB layout and host board power supply noise filtering are given in XFP MSA INF8077i Rev. 4.5

# 15

## 3.13 Module Outline

(Specifications are in mm unless otherwise noted)

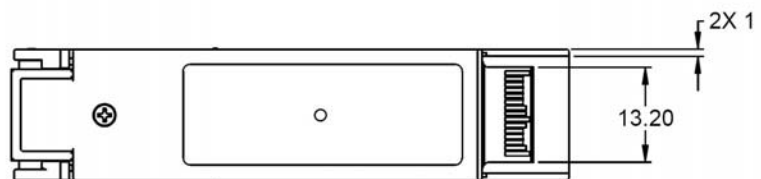
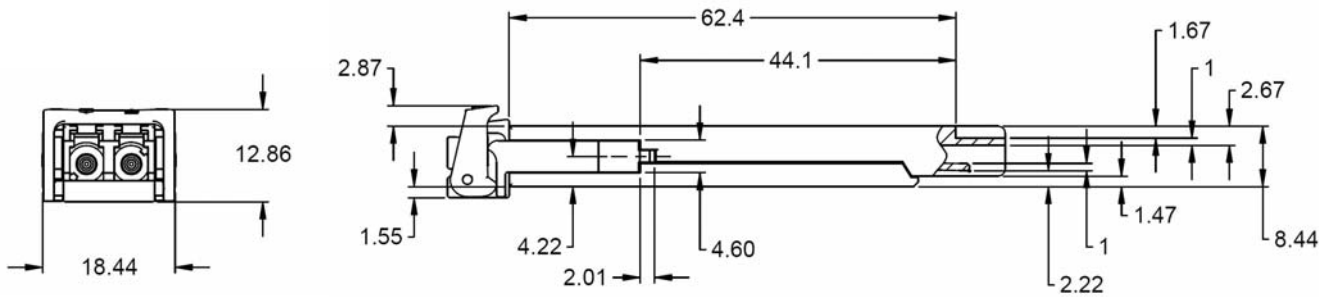
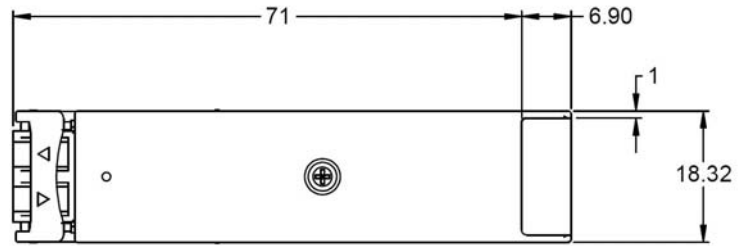
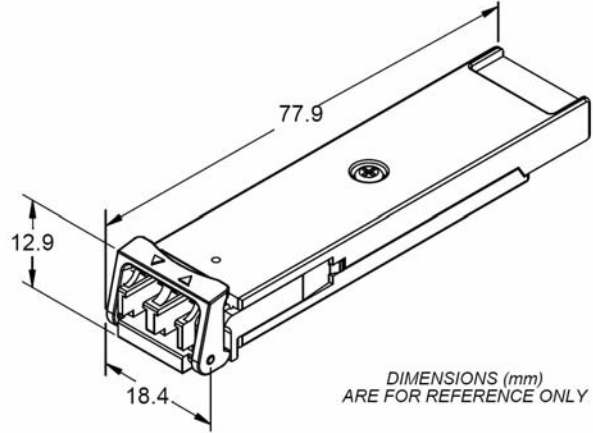

### 3.14 Connectors

#### Fiber

The XFP module has a duplex LC receptacle connector.

#### Electrical

The electrical connector is the 30-way, two row PCB edge connector. Customer connector is Tyco / AMP Part No. 788862C or equivalent.

## Section 4 Related Information

Other information related to the JDSU 10 Gb/s 850 nm XFP optical transceiver includes:

- Section 4.1 Packing and handling instructions
- Section 4.2 ESD discharge (ESD)
- Section 4.3 Eye safety

### 4.1 Package and Handling Instructions

#### Connector covers

The JDSU 10 Gb/s 850 nm XFP optical transceiver is supplied with an LC duplex receptacle. The connector plug supplied protects the connector during standard manufacturing processes and handling by preventing contamination from dust, aqueous solutions, body oils, or airborne particles.

Note: It is recommended that the connector plug remain on whenever the transceiver optical fiber connector is not inserted.

#### Recommended cleaning and de-greasing chemicals

JDSU recommends the use of methyl, isopropyl and isobutyl alcohols for cleaning.

Do not use halogenated hydrocarbons (e.g. trichloroethane, ketones such as acetone, chloroform, ethyl acetate, MEK, methylene chloride, methylene dichloride, phenol, N-methylpyrrolidone).

This product is not designed for aqueous wash.

#### Housing

The JDSU 10 Gb/s 850 nm XFP optical transceiver housing is made from zinc.



## 4.2 ESD Discharge (ESD)

### Handling

Normal ESD precautions are required during the handling of this module. This transceiver is shipped in ESD protective packaging. It should be removed from the packaging and otherwise handled in an ESD protected environment utilizing standard grounded benches, floor mats, and wrist straps.

### Test and operation

In most applications, the optical connector will protrude through the system chassis and be subjected to the same ESD environment as the system. Once properly installed in the system, this transceiver should meet and exceed common ESD testing practices and fulfill system ESD requirements.

Typical of optical transceivers, this module's receiver contains a highly sensitive optical detector and amplifier which may become temporarily saturated during an ESD strike. This could result in a short burst of bit errors. Such an event might require that the application re-acquire synchronization at the higher layers (e.g. Serializer / Deserializer chip).

## 4.3 Eye Safety

The JDSU 10 Gb/s 850 nm XFP optical transceiver is an international Class 1 laser product IEC60825-1 second edition 2007. The JDSU 10 Gb/s 850 nm XFP optical transceiver is an eye safe device when operated within the limits of this specification.

Operating this product in a manner inconsistent with intended usage and specification may result in hazardous radiation exposure.

### Caution

Tampering with this laser based product or operating this product outside the limits of this specification may be considered an act of "manufacturing," and will require, under law, recertification of the modified product with the U.S. Food and Drug Administration (21 CFR 1040).



**Order Information**

For more information on this or other products and their availability, please contact your local JDSU account manager or JDSU directly at 1-800-498-JDSU (5378) in North America and +800-5378-JDSU worldwide or via e-mail at [customer.service@jdsu.com](mailto:customer.service@jdsu.com).

**Sample: PLRXXL-SC-S43-C1**

Part Number	Description
PLRXXL-SC-S43-C1	RoHS6/6 compliant, 10GbE / FC SR / SW, 850 nm, commercial temperature range, 10 Gb/s XFP optical transceiver

**NORTH AMERICA: 800 498-JDSU (5378)**

**WORLDWIDE: +800 5378-JDSU**

**WEBSITE: [www.jdsu.com](http://www.jdsu.com)**