

MARKETING SALES DRAWING
DIMENSIONS IN INCHES - DO NOT SCALE THIS DRAWING
DIMENSIONS IN METRIC - []

Electrical Testing
per Tusonix standard
test plans and Mil-Std-202
Test Methods.

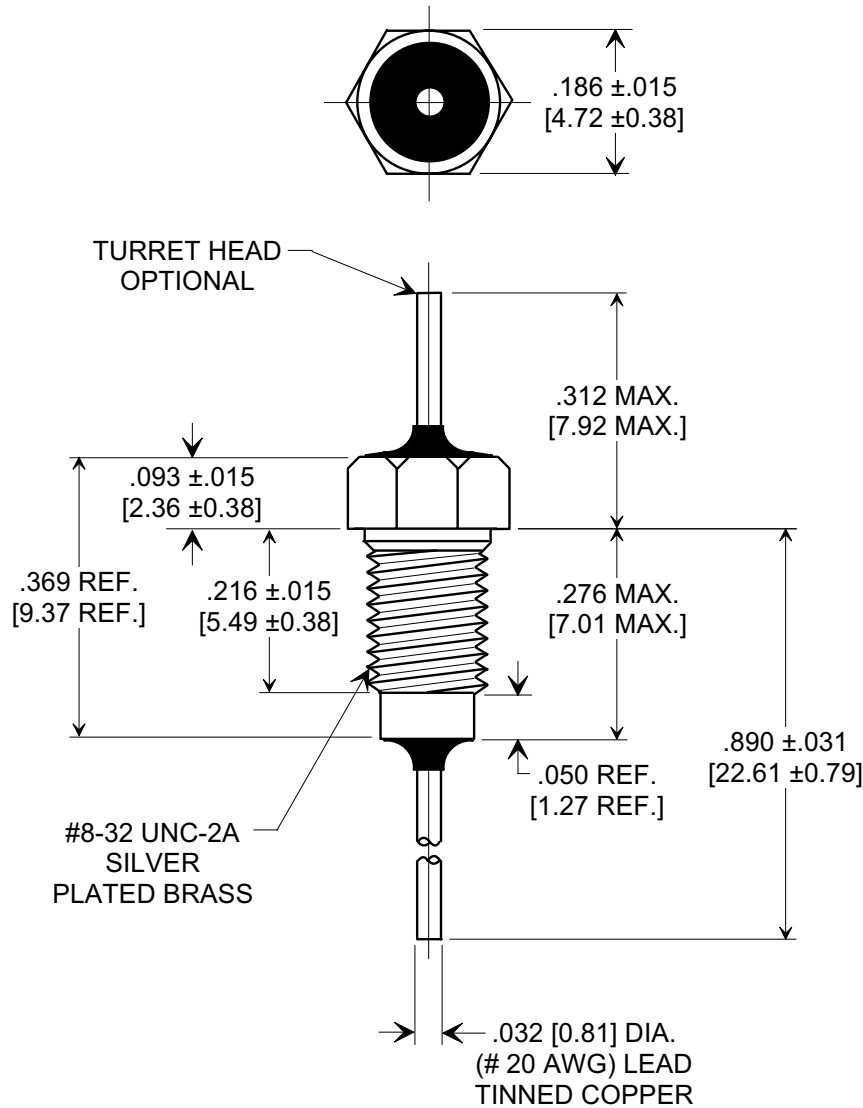
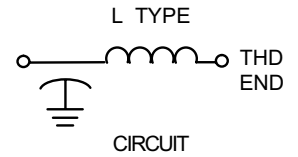
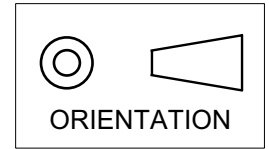

MIN. CAP.	125°C WORKING VOLTAGE	CURRENT I _{dc}	MINIMUM NO LOAD INSERTION LOSS (dB) @ 25°C PER MIL-STD-220					
			1 MHz	10 MHz	100 MHz	200 MHz	1 GHz	10 GHz
22,000 pF	100 VDC	10 A	10	30	42	45	60	60

X-2015 Rev-0	REVISION RECORD				--TOLERANCES-- Unless Otherwise Specified	Title EMI FILTER MIL 15733/61-0013	
	Original Release C.O.	WAS SK7096-004-S E.C.06-14-93	0				
	930528-2	DWG. REVISED E.C. 05-12-94	1		DECIMAL ±	Drawn S.M. 05-04-99	Scale 4 X
	940217-3	RDN TO COMP FMT & DIM .312 REVISED. DIM .890 ADDED & REVISED TITLE. S.M. 0-04-99	2		ANGLES ±	Approved J.Mc. 05-04-99	
19990430-3-01	REVISED TITLE & ADDED ORIENTATION. S.M. 12-18-01	3		TUSONIX TUCSON, ARIZONA	A	4251-502	
20011210-2-05	REVISED THREAD NOTE. S.M. 11-21-05	4					
20051116-3-03							