

Infinion's PLB2224 is a highly integrated Layer 2+ switch-on-a-chip with twenty-four 10/100 Mbps and two 10/100/1000 Mbps Ethernet ports. The PLB2224 provides wire-speed, full-duplex switching capability on all ports. On-chip memory for packet buffers and address tables eliminate the need for external memory resulting in smaller PCB real estate and lower power consumption.

The PLB2224 features support unmanaged, minimally managed (Smart), and fully managed Layer-2 switch configurations. The Gigabit ports can be used to daisy chain multiple devices in a system providing even higher port counts for medium to large office buildings and multi-tenant, multi-dwelling units where power and space are at a premium. The high level of integration in PLB2224 allows for design of systems with fewer components and a low bill of material.



**Features**

- 24 + 2G Single Chip Switch
- On-chip Memory for Packet Buffer and Address Tables. No External Memory Required.
  - 12 Mb of embedded DRAM for Packets, for up to 1,000 Packets
  - Up to 8K MAC Address Entries with Auto Learning and Aging
- Supported Switch Configurations
  - Fixed – Either 24 + 2G, 48 or 48 + 2G
  - Stack – Up to 7 devices per stack (168 + 2G). Stack controlled using I<sup>2</sup>C Interface
- L2 Switching with L2+ Packet Processing
  - Generic Pattern Recognition Engine with 16 User Programmable Patterns. Search for Pattern Match within first 64B of packet data.
  - Can be used to detect Control Packets such as IGMP (IP Multicast) and GVRP (VLAN Membership).
  - Lookup Results Used to Filter and/or Monitor Packets, Change Forwarding Scope, Modify Queue Assignment, and Collect Statistics.

- Wire-Speed Performance on All Ports
  - Fast Ethernet Ports Support 10/100 Mbps
  - Gigabit Ethernet Ports Support 10/100/1000 Mbps
  - Half/Full Duplex Support on All Ports at 10/100 Mbps, Full Duplex at 1000 Mbps
  - Auto-negotiation Support for All Ports
  - 802.3x compliant Flow Control on Full Duplex Ports, Congestion-based Flow Control on Half Duplex Ports
- Statistics Counters for SNMP MIB II & RMON1 MIB
- Port Monitoring

**Supported Standards**

- Bridging - IEEE 802.1D Compliant with Support for Spanning Tree
- VLAN - IEEE 802.1Q Compliant
  - Up to 1K Active VLANs
  - Port or Tag based
- Link Aggregation - IEEE 802.3ad Compliant
  - 2/4/8 FE Ports or 2 GE Ports per Trunk. Multiple Trunks per Device. Support for Resiliency

- Advanced Queuing and Scheduling for QoS - IEEE 802.1p Compliant
  - 2 Queues per Port Supporting Strict Priority and Weighted Fair Queue (WFQ) Scheduling

**Interfaces**

- SMI1 for Fast Ethernet Ports
- MII/GMII/TBI for Gigabit Ethernet Ports
- 32-Bit, 33 MHz PCI or Generic Interface for External CPU
- I<sup>2</sup>C Interface for Configuration EEPROM and Optional CPU Connection.
- Simple Interface for Status LEDs.

**Other**

- Power Consumption less than 3 W.
- 1.8 V, 0.18 μ Logic Process with Embedded DRAM, 3.3 V Tolerant I/Os.

Type	Package
PLB2224	Plastic BGA-272

PLB 2 2 2 4  
24 + 2G Switch on a Chip  
with Embedded Memory



Never stop thinking.

## Typical Switch Configurations

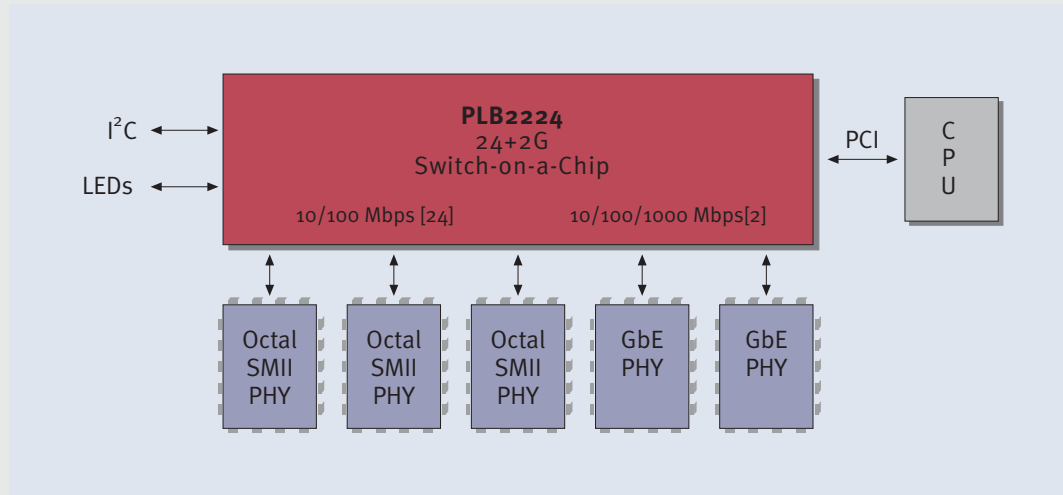

Small Form Factor 24 + 2G Layer-2 Switch

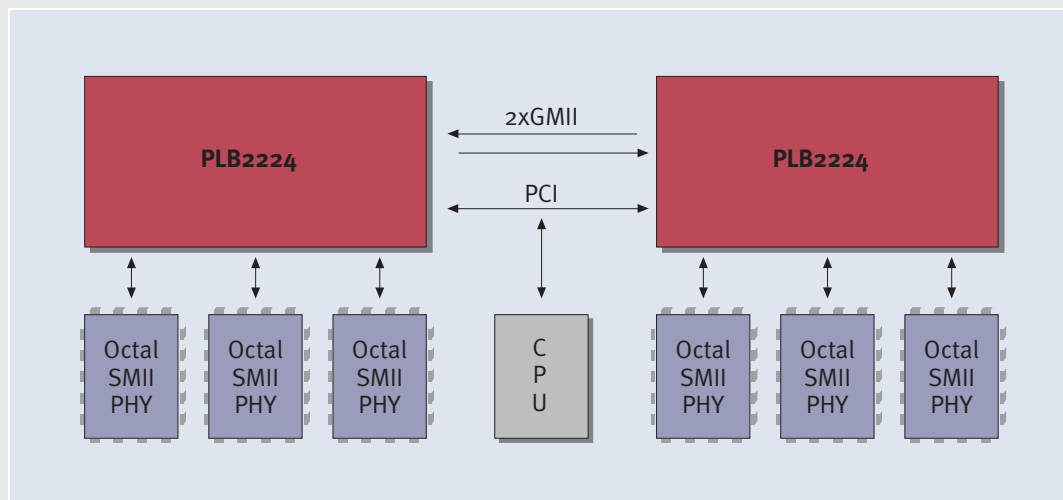

48-Port Managed Layer-2 Switch

### Applications

- Unmanaged, minimally managed (Smart), or fully managed Layer-2 switches with small form factors.
- 10BaseS™ switches for the MDU/MTU markets.
- Ethernet port concentrators for data centers.
- Ethernet back-planes for server clusters.

#### How to reach us:

<http://www.infineon.com>

Infineon Technologies Ardent, Inc.  
510 Logue Avenue  
Mountain View, CA 94043 USA

Published by  
Infineon Technologies AG,  
Bereich Kommunikation,  
St.-Martin-Strasse 53,  
D-81541 München

© Infineon Technologies AG 2001. All Rights Reserved.

#### Attention please!

The information herein is given to describe certain components and shall not be considered as warranted characteristics.

Terms of delivery and rights to technical change reserved.

We hereby disclaim any and all warranties, including but not limited to warranties of non-infringement, regarding circuits, descriptions and charts stated herein.

Infineon Technologies is an approved CECC manufacturer.

#### Information

For further information on technology, delivery terms and conditions and prices please contact your nearest Infineon Technologies Office in Germany or our Infineon Technologies Representatives worldwide.

#### Warnings

Due to technical requirements components may contain dangerous substances. For information on the types in question please contact your nearest Infineon Technologies Office.

Infineon Technologies Components may only be used in life-support devices or systems with the express written approval of Infineon Technologies, if a failure of such components can reasonably be expected to cause the failure of that life-support device or system, or to affect the safety or effectiveness of that device or system. Life support devices or systems are intended to be implanted in the human body, or to support and/or maintain and sustain and/or protect human life. If they fail, it is reasonable to assume that the health of the user or other persons may be endangered.