

# SCAN90CP02

## 1.5 Gbps 2x2 LVDS Crosspoint Switch with Pre-Emphasis and IEEE 1149.6

### General Description

The SCAN90CP02 is a 1.5 Gbps 2 x 2 LVDS crosspoint switch. High speed data paths and flow-through pinout minimize internal device jitter, while configurable 0/25/50/100% pre-emphasis overcomes external ISI jitter effects of lossy backplanes and cables. The differential inputs interface to LVDS and Bus LVDS signals such as those on National's 10-, 16-, and 18-bit Bus LVDS SerDes, as well as CML and LVPECL. The SCAN90CP02 can also be used with ASICs and FPGAs. The non-blocking crosspoint architecture is pin-configurable as a 1:2 clock or data splitter, 2:1 redundancy mux, crossover function, or dual buffer for signal booster and stub hider applications.

Integrated IEEE 1149.1 (JTAG) and 1149.6 circuitry supports testability of both single-ended LVTTTL/CMOS and differential LVDS PCB interconnect. The 3.3V supply, CMOS process, and LVDS I/O ensure high performance at low power over the entire industrial -40 to +85°C temperature range.

### Features

- 1.5 Gbps per channel
- Low power: 70 mA in dual repeater mode @ 1.5 Gbps
- Low output jitter
- Configurable 0/25/50/100% pre-emphasis drives lossy backplanes and cables
- Non-blocking architecture allows 1:2 splitter, 2:1 mux, crossover, and dual buffer configurations
- Flow-through pinout
- LVDS/BLVDS/CML/LVPECL inputs, LVDS Outputs
- IEEE 1149.1 and 1149.6 compliant
- Single 3.3V supply
- Separate control of inputs and outputs allows for power savings
- Industrial -40 to +85°C temperature range
- 28-lead LLP package, or 32-lead LQFP package

### Block Diagram

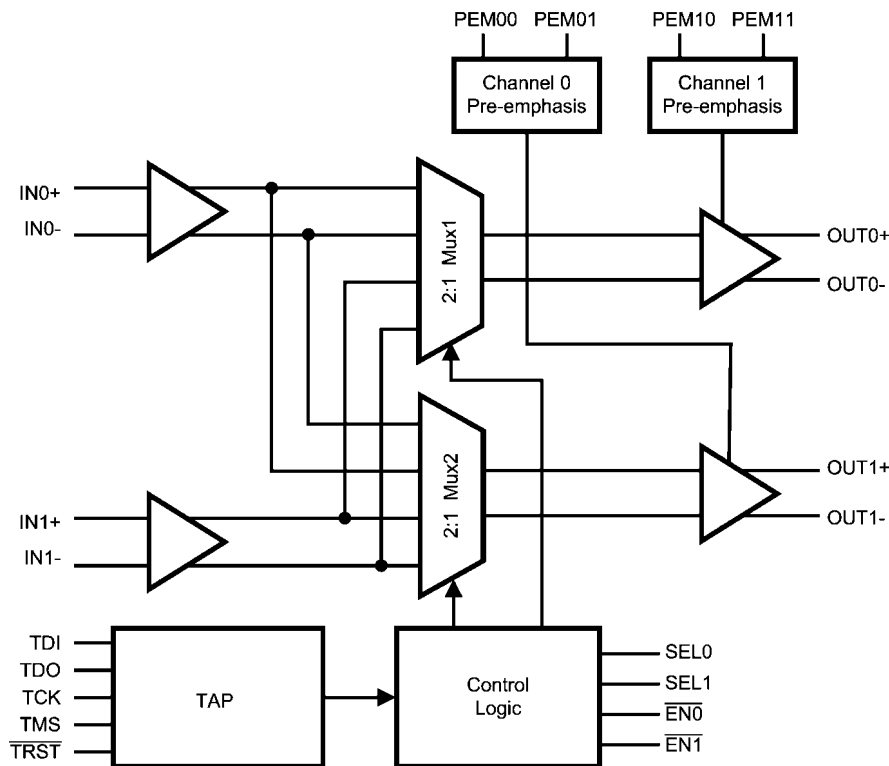

FIGURE 1. SCAN90CP02 Block Diagram

20071401

TRI-STATE® is a registered trademark of National Semiconductor Corporation.

## Pin Descriptions

Pin Name	LLP Pin Number	LQFP Pin Number	I/O, Type	Description
<b>DIFFERENTIAL INPUTS COMMON TO ALL MUXES</b>				
IN0+	9	9	I, LVDS	Inverting and non-inverting differential inputs. LVDS, Bus LVDS, CML, or LVPECL compatible.
IN0-	10	10		
IN1+	12	13	I, LVDS	Inverting and non-inverting differential inputs. LVDS, Bus LVDS, CML, or LVPECL compatible.
IN1-	13	14		
<b>SWITCHED DIFFERENTIAL OUTPUTS</b>				
OUT0+	27	32	O, LVDS	Inverting and non-inverting differential outputs. OUT0± can be connected to any one pair IN0±, or IN1±. LVDS compatible (Note 2).
OUT0-	26	31		
OUT1+	24	28	O, LVDS	Inverting and non-inverting differential outputs. OUT1± can be connected to any one pair IN0±, or IN1±. LVDS compatible (Note 2).
OUT1-	23	27		
<b>DIGITAL CONTROL INTERFACE</b>				
SEL0, SEL1	6 5	7 6	I, LVTTTL	Select Control Inputs
EN0, EN1	7 15	8 17	I, LVTTTL	Output Enable Inputs
PEM00, PEM01	4 3	4 3	I, LVTTTL	Channel 0 Output Pre-emphasis Control Inputs
PEM10, PEM11	2 1	2 1	I, LVTTTL	Channel 1 Output Pre-emphasis Control Inputs
TDI	19	22	I, LVTTTL	Test Data Input to support IEEE 1149.1 features
TDO	20	23	O, LVTTTL	Test Data Output to support IEEE 1149.1 features
TMS	18	21	I, LVTTTL	Test Mode Select to support IEEE 1149.1 features
TCK	17	19	I, LVTTTL	Test Clock to support IEEE 1149.1 features
TRST	21	24	I, LVTTTL	Test Reset to support IEEE 1149.1 features
N/C	8, 28			Not Connected
<b>POWER</b>				
V <sub>DD</sub>	11, 14, 16, 22, 25	12, 16, 18, 25, 29	I, Power	V <sub>DD</sub> = 3.3V ±0.3V. At least 4 low ESR 0.01 μF bypass capacitors should be connected from V <sub>DD</sub> to GND plane.
GND	(Note 1)	5, 11, 15, 20, 26, 30		Ground reference to LVDS and CMOS circuitry. For the LLP package, the DAP is used as the primary GND connection to the device. The DAP is the exposed metal contact at the bottom of the LLP-28 package. It should be connected to the ground plane with at least 4 vias for optimal AC and thermal performance.

**Note 1:** Note that for the LLP package GND is not an actual pin on the package, the GND is connected thru the DAP on the back side of the LLP package.

**Note 2:** The LVDS outputs do not support a multidrop (BLVDS) environment. The LVDS output characteristics of the SCAN90CP02 device have been optimized for point-to-point backplane and cable applications.

## Connection Diagrams

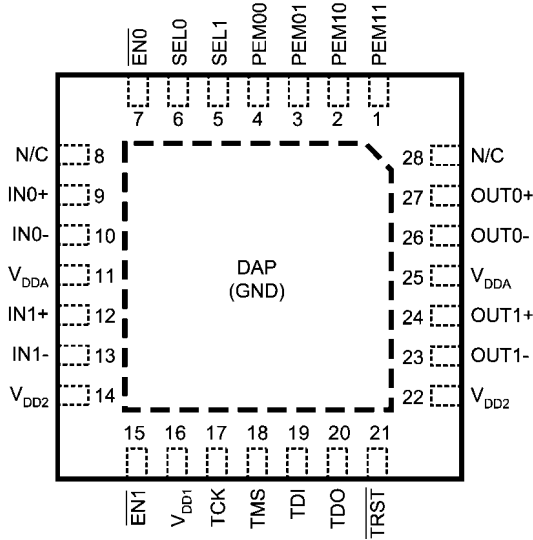

LLP Top View  
DAP = GND

20071403

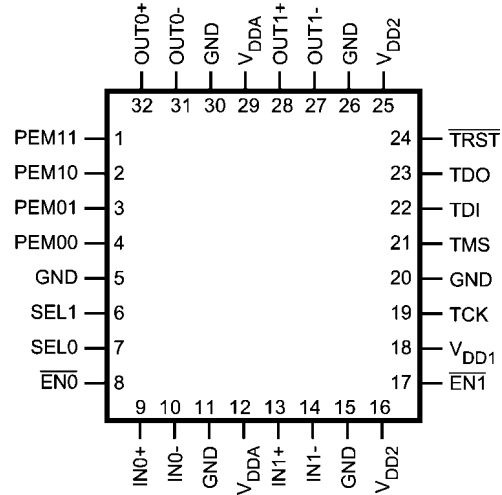

LQFP Top View

20071404

## Configuration Select Truth Table

SEL0	SEL1	EN0	EN1	OUT0	OUT1	Mode
0	0	0	0	IN0	IN0	1:2 Splitter (IN1 powered down)
0	1	0	0	IN0	IN1	Dual Channel Repeater
1	0	0	0	IN1	IN0	Dual Channel Switch
1	1	0	0	IN1	IN1	1:2 Splitter (IN0 powered down)
0	1	0	1	IN0	PD	Single Channel Repeater (Channel 1 powered down)
1	1	0	1	IN1	PD	Single Channel Switch (IN0 and OUT1 powered down)
0	0	1	0	PD	IN0	Single Channel Switch (IN1 and OUT0 powered down)
0	1	1	0	PD	IN1	Single Channel Repeater (Channel 0 powered down)
X	X	1	1	PD	PD	Both Channels in Power Down Mode
0	0	0	1			Invalid State*
1	0	0	1			Invalid State*
1	0	1	0			Invalid State*
1	1	1	0			Invalid State*

PD = Power Down mode to minimize power consumption  
X = Don't Care

\* Entering these states is not forbidden, however device operation is not defined in these states.

## Pre-Emphasis

The pre-emphasis is used to compensate for long or lossy transmission media. Separate pins are provided for each output to minimize power consumption. Pre-emphasis is programmable to be off or to preset values per the Pre-emphasis Control Selection Table.

## Output Characteristics

The output characteristics of the SCAN90CP02 device have been optimized for point-to-point backplane and cable applications.

Pre-emphasis Control Selection Table

Channel 0		Channel 1		Pre-emphasis
PEM01	PEM00	PEM11	PEM10	
0	0	0	0	0%
0	1	0	1	25%
1	0	1	0	50%
1	1	1	1	100%

## Applications Information

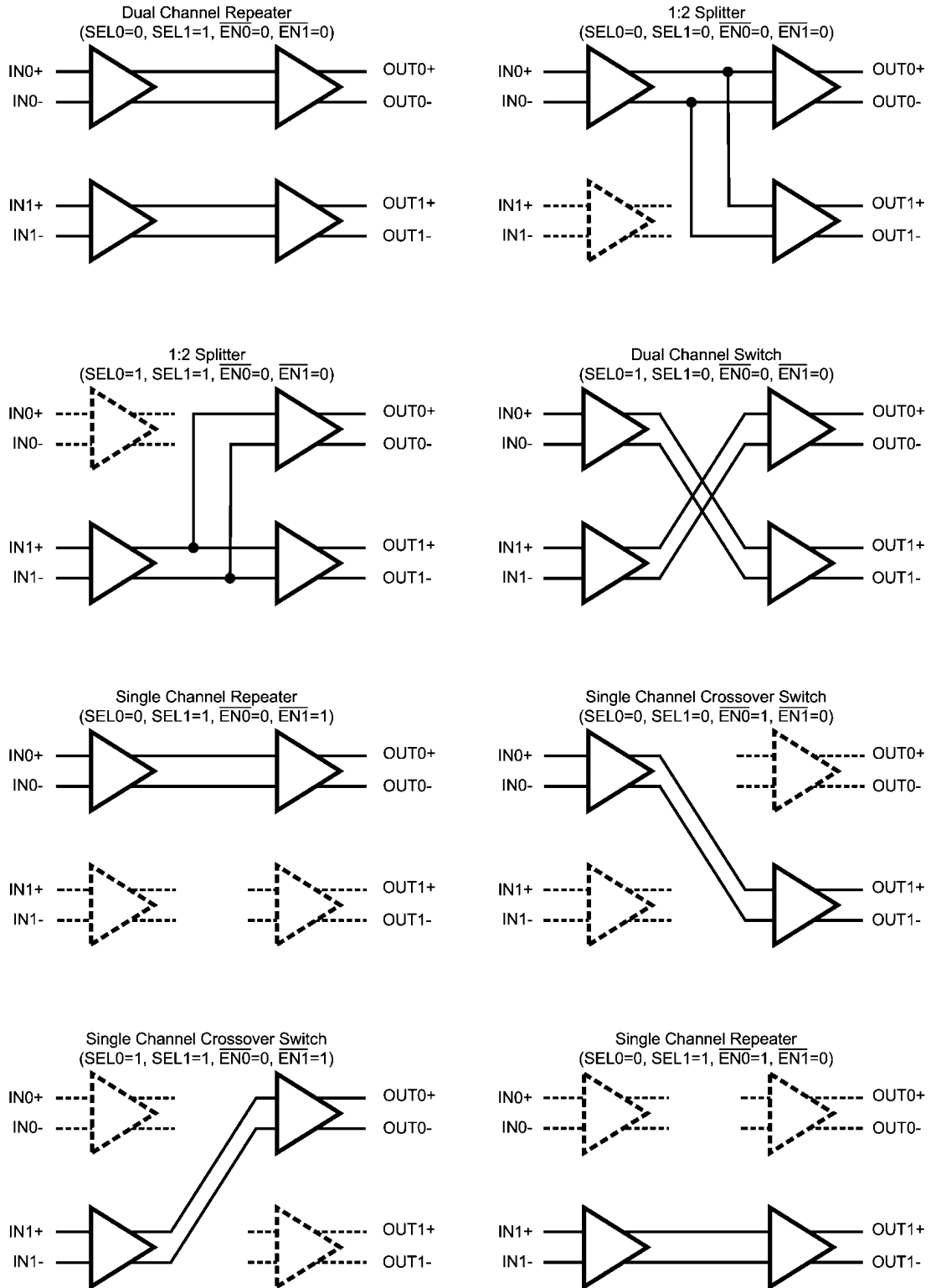

20071402

FIGURE 2. SCAN90CP02 Configuration Select Decode

## Absolute Maximum Ratings (Note 3)

If Military/Aerospace specified devices are required, please contact the National Semiconductor Sales Office/ Distributors for availability and specifications.

Supply Voltage ( $V_{DD}$ )	-0.3V to +4.0V
CMOS Input Voltage	-0.3V to ( $V_{DD} + 0.3V$ )
LVDS Receiver Input Voltage	-0.3V to +3.6V
LVDS Driver Output Voltage	-0.3V to +3.6V
LVDS Output Short Circuit Current	40mA
Junction Temperature	+150°C
Storage Temperature	-65°C to +150°C
Lead Temperature (Soldering, 4sec.)	+260°C
Maximum Package Power Dissipation at 25°C	
LLP-28	4.31 W
LQFP-32	1.47 W
Derating above 25°C	
LLP-28	34.5 mW/°C

LQFP-32	11.8 mW/°C
Thermal Resistance, $\theta_{JA}$	
LLP-28	29°C/W
LQFP-32	85°C/W
ESD Rating	
HBM, 1.5 k $\Omega$ , 100 pF	6.5 kV
EIAJ, 0 $\Omega$ , 200 pF	>250V

## Recommended Operating Conditions

	Min	Typ	Max	Unit
Supply Voltage ( $V_{DD-GND}$ )	3.0	3.3	3.6	V
Receiver Input Voltage	0		3.6	V
Operating Free Air Temperature	-40	25	85	°C
Junction Temperature			150	°C

## Electrical Characteristics

Over recommended operating supply and temperature ranges unless other specified.

Symbol	Parameter	Conditions	Min	Typ (Note 4)	Max	Units
<b>LVTTTL DC SPECIFICATIONS (SEL0, SEL1, EN1, EN2, PEM00, PEM01, PEM10, PEM11, TDI, TCK, TMS, TRST)</b>						
$V_{IH}$	High Level Input Voltage		2.0		$V_{DD}$	V
$V_{IL}$	Low Level Input Voltage		GND		0.8	V
$I_{IH}$	High Level Input Current	$V_{IN} = V_{DD} = V_{DDMAX}$	-10		+10	$\mu$ A
$I_{IL}$	Low Level Input Current	$V_{IN} = V_{SS}, V_{DD} = V_{DDMAX}$	-10		+10	$\mu$ A
$I_{ILR}$	Low Level Input Current	TDI, TMS, TRST	-40		-200	$\mu$ A
$C_{IN1}$	Input Capacitance	Any Digital Input Pin to $V_{SS}$		3.5		pF
$C_{OUT1}$	Output Capacitance	Any Digital Output Pin to $V_{SS}$		5.5		pF
$V_{CL}$	Input Clamp Voltage	$I_{CL} = -18$ mA	-1.5	-0.8		V
$V_{OH}$	High Level Output Voltage (TDO)	$I_{OH} = -12$ mA, $V_{DD} = 3.0$ V	2.4			V
		$I_{OH} = -100$ $\mu$ A, $V_{DD} = 3.0$ V	$V_{DD}-0.2$			V
$V_{OL}$	Low Level Output Voltage (TDO)	$I_{OL} = 12$ mA, $V_{DD} = 3.0$ V			0.5	V
		$I_{OL} = 100$ $\mu$ A, $V_{DD} = 3.0$ V			0.2	V
$I_{OS}$	Output Short Circuit Current	TDO	-15		-125	mA
<b>LVDS INPUT DC SPECIFICATIONS (IN0<math>\pm</math>, IN1<math>\pm</math>)</b>						
$V_{TH}$	Differential Input High Threshold (Note 5)	$V_{CM} = 0.8V$ or 1.2V or 3.55V, $V_{DD} = 3.6V$		0	100	mV
$V_{TL}$	Differential Input Low Threshold	$V_{CM} = 0.8V$ or 1.2V or 3.55V, $V_{DD} = 3.6V$	-100	0		mV
$V_{ID}$	Differential Input Voltage	$V_{CM} = 0.8V$ to 3.55V, $V_{DD} = 3.6V$	100			mV
$V_{CMR}$	Common Mode Voltage Range	$V_{ID} = 150$ mV, $V_{DD} = 3.6V$	0.05		3.55	V
$C_{IN2}$	Input Capacitance	IN+ or IN- to $V_{SS}$		3.5		pF
$I_{IN}$	Input Current	$V_{IN} = 3.6V$ , $V_{DD} = V_{DDMAX}$ or 0V	-10		+10	$\mu$ A
		$V_{IN} = 0V$ , $V_{DD} = V_{DDMAX}$ or 0V	-10		+10	$\mu$ A

Symbol	Parameter	Conditions	Min	Typ (Note 4)	Max	Units	
<b>LVDS OUTPUT DC SPECIFICATIONS (OUT0±, OUT1±)</b>							
V <sub>OD</sub>	Differential Output Voltage, 0% Pre-emphasis (Note 5)	R <sub>L</sub> = 100Ω between OUT+ and OUT-	250	400	575	mV	
ΔV <sub>OD</sub>	Change in V <sub>OD</sub> between Complementary States		-35		35	mV	
V <sub>OS</sub>	Offset Voltage (Note 6)		1.09	1.25	1.475	V	
ΔV <sub>OS</sub>	Change in V <sub>OS</sub> between Complementary States		-35		35	mV	
I <sub>OS</sub>	Output Short Circuit Current, One Complementary Output	OUT+ or OUT- Short to GND		-60	-90	mA	
C <sub>OUT2</sub>	Output Capacitance	OUT+ or OUT- to GND when TRI-STATE®		5.5		pF	
<b>SUPPLY CURRENT (Static)</b>							
I <sub>CC0</sub>	Supply Current	All inputs and outputs enabled and active, terminated with differential load of 100Ω between OUT+ and OUT-.		42	60	mA	
I <sub>CC1</sub>	Supply Current - one channel powered down	Single channel crossover switch or single channel repeater modes (1 channel active, one channel in power down mode)		22	30	mA	
I <sub>CC2</sub>	Supply Current - one input powered down	Splitter mode (One input powered down, both outputs active)		30	40	mA	
I <sub>CCZ</sub>	TRI-STATE Supply Current	Both input/output Channels in Power Down Mode		1.4	2.5	mA	
<b>SWITCHING CHARACTERISTICS—LVDS OUTPUTS (Figures 3, 4)</b>							
t <sub>LHT</sub>	Differential Low to High Transition Time	Use an alternating 1 and 0 pattern at 200 Mb/s, measure between 20% and 80% of V <sub>OD</sub> .	70	150	215	ps	
t <sub>HLT</sub>	Differential High to Low Transition Time		50	135	180	ps	
t <sub>PLHD</sub>	Differential Low to High Propagation Delay	Use an alternating 1 and 0 pattern at 200 Mb/s, measure at 50% V <sub>OD</sub> between input to output.	0.5	2.4	3.5	ns	
t <sub>PHLD</sub>	Differential High to Low Propagation Delay		0.5	2.4	3.5	ns	
t <sub>SKD1</sub>	Pulse Skew	t <sub>PLHD</sub> - t <sub>PHLD</sub>		55	120	ps	
t <sub>SKCC</sub>	Output Channel to Channel Skew	Difference in propagation delay (t <sub>PLHD</sub> or t <sub>PHLD</sub> ) among all output channels in Splitter mode (any one input to all outputs).	0	130	315	ps	
t <sub>JIT</sub>	Jitter (0% Pre-emphasis) (Note 7)	RJ - Alternating 1/0 @ 750 MHz (Note 8)		1.4	2.5	psrms	
		DJ - K28.5 Pattern 1.5 Gbps (Note 9)	LQFP		110	140	psp-p
			LLP		42	75	psp-p
		TJ - PRBS 2 <sup>23</sup> -1 Pattern 1.5 Gbps (Note 10)	LQFP		113	148	psp-p
LLP			93	126	psp-p		
t <sub>ON</sub>	LVDS Output Enable Time	Time from $\overline{ENx}$ to OUT± change from TRI-STATE to active.	50	110	150	ns	
t <sub>OFF</sub>	LVDS Output Disable Time	Time from $\overline{ENx}$ to OUT± change from active to TRI-STATE.		5	12	ns	
t <sub>SW</sub>	LVDS Switching Time SELx to OUT±	Time from configuration select (SELx) to new switch configuration effective for OUT±.		110	150	ns	

## SCAN Circuitry Timing Requirements

Symbol	Parameter	Conditions	Min	Typ	Max	Units
$f_{MAX}$	Maximum TCK Clock Frequency	$R_L = 500\Omega$ , $C_L = 35\text{ pF}$	25.0			MHz
$t_S$	TDI to TCK, H or L		1.0			ns
$t_H$	TDI to TCK, H or L		2.0			ns
$t_S$	TMS to TCK, H or L		2.0			ns
$t_H$	TMS to TCK, H or L		1.5			ns
$t_W$	TCK Pulse Width, H or L		10.0			ns
$t_W$	$\overline{TRST}$ Pulse Width, L		2.5			ns
$t_{REC}$	Recovery Time, $\overline{TRST}$ to TCK		2.0			ns

**Note 3:** "Absolute Maximum Ratings" are the ratings beyond which the safety of the device cannot be guaranteed. They are not meant to imply that the device should be operated at these limits.

**Note 4:** Typical parameters are measured at  $V_{DD} = 3.3V$ ,  $T_A = 25^\circ C$ . They are for reference purposes, and are not production-tested.

**Note 5:** Differential output voltage  $V_{OD}$  is defined as  $ABS(OUT+ - OUT-)$ . Differential input voltage  $V_{ID}$  is defined as  $ABS(IN+ - IN-)$ .

**Note 6:** Output offset voltage  $V_{OS}$  is defined as the average of the LVDS single-ended output voltages at logic high and logic low states.

**Note 7:** Jitter is not production tested, but guaranteed through characterization on a sample basis.

**Note 8:** Random Jitter, or RJ, is measured RMS with a histogram including 1500 histogram window hits. The input voltage =  $V_{ID} = 500mV$ , 50% duty cycle at 750MHz,  $t_r = t_f = 50ps$  (20% to 80%).

**Note 9:** Deterministic Jitter, or DJ, is measured to a histogram mean with a sample size of 350 hits. The input voltage =  $V_{ID} = 500mV$ , K28.5 pattern at 1.5 Gbps,  $t_r = t_f = 50ps$  (20% to 80%). The K28.5 pattern is repeating bit streams of (0011111010 1100000101).

**Note 10:** Total Jitter, or TJ, is measured peak to peak with a histogram including 3500 window hits. Stimulus and fixture jitter has been subtracted. The input voltage =  $V_{ID} = 500mV$ , 2<sup>23</sup>-1 PRBS pattern at 1.5 Gbps,  $t_r = t_f = 50ps$  (20% to 80%).

## Timing Diagrams

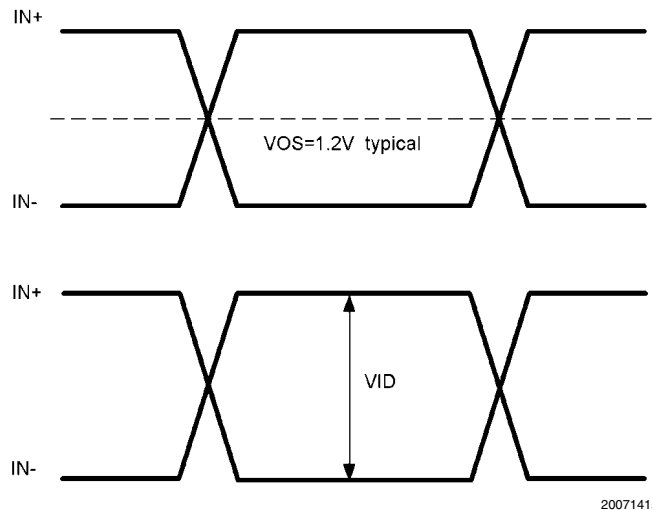

FIGURE 3. LVDS Signals

20071415

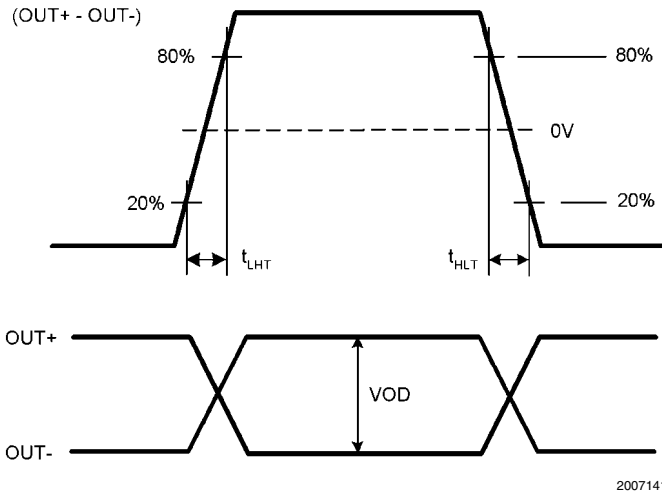

FIGURE 4. LVDS Output Transition Time

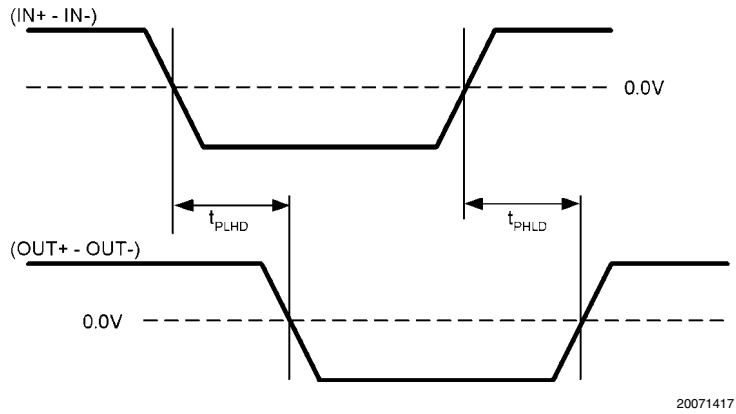

FIGURE 5. LVDS Output Propagation Delay

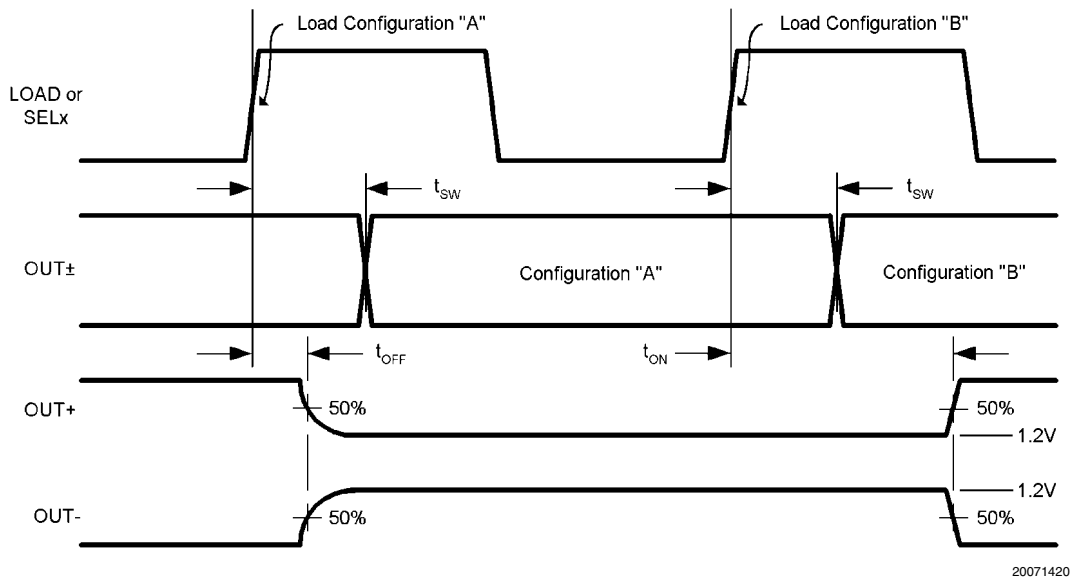

FIGURE 6. Configuration and Output Enable/Disable Timing



## Input Interfacing

The SCAN90CP02 accepts differential signals and allow simple AC or DC coupling. With a wide common mode range, the

SCAN90CP02 can be DC-coupled with all common differential drivers (i.e. LVPECL, LVDS, CML). The following three figures illustrate typical DC-coupled interface to common differential drivers.

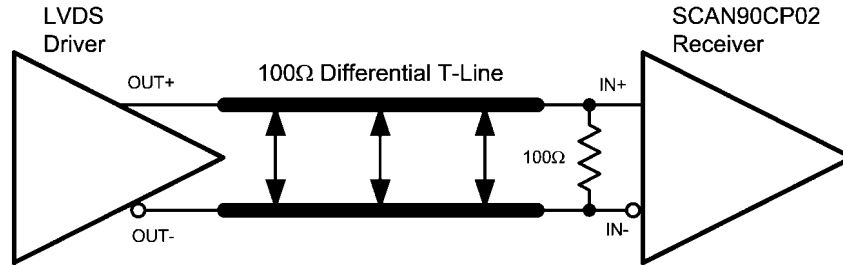

Typical LVDS Driver DC-Coupled Interface to SCAN90CP02 Input

20071421

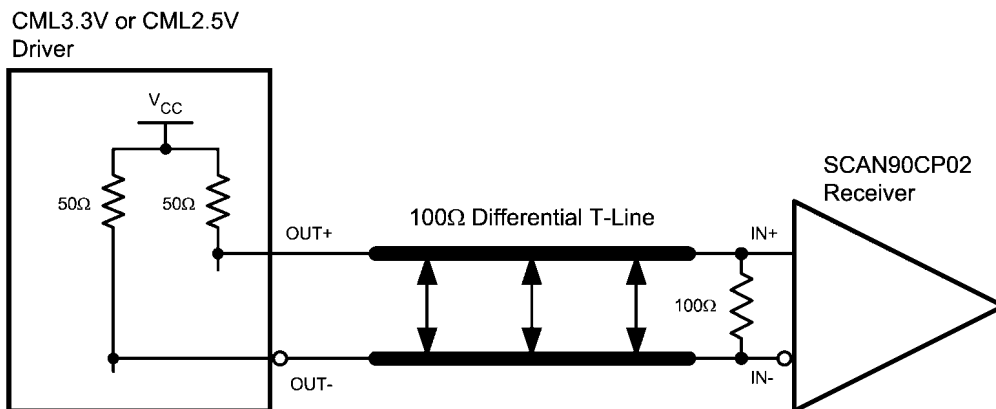

Typical CML Driver DC-Coupled Interface to SCAN90CP02 Input

20071422

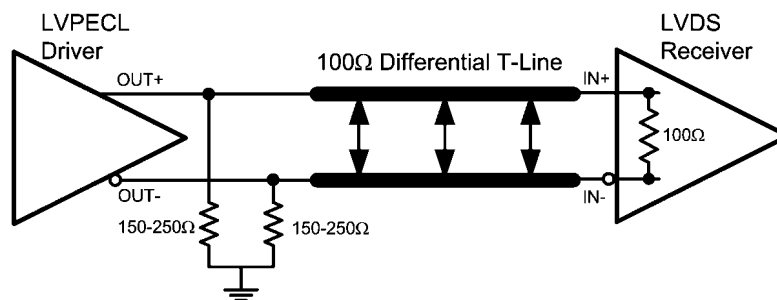

Typical LVPECL Driver DC-Coupled Interface to SCAN90CP02 Input

20071423

## Output Interfacing

The SCAN90CP02 outputs signals that are compliant to the LVDS standard. Their outputs can be DC-coupled to most common differential receivers. The following figure illustrates typical DC-coupled interface to common differential receivers

and assumes that the receivers have high impedance inputs. While most differential receivers have a common mode input range that can accommodate LVDS compliant signals, it is recommended to check respective receiver's data sheet prior to implementing the suggested interface implementation.

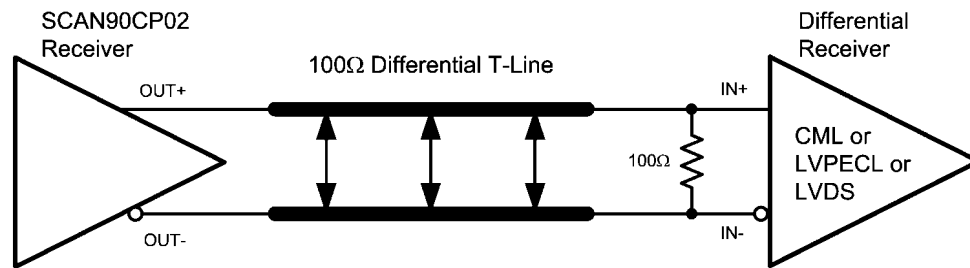

20071424

**Typical SCAN90CP02 Output DC-Coupled Interface to an LVDS, CML or LVPECL Receiver**

# Typical Performance Characteristics for LLP Package

**Power Supply Current vs. Bit Data Rate**

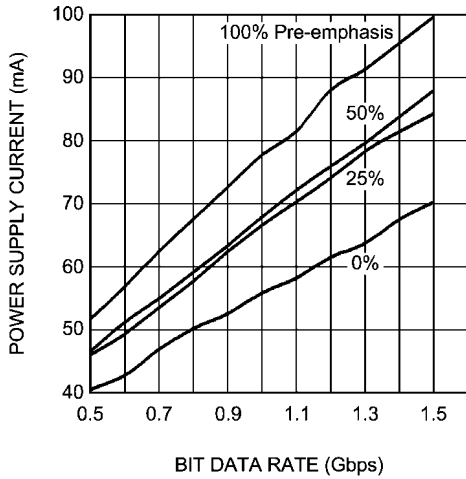

20071441

Dynamic power supply current was measured while running a PRBS 2<sup>23</sup>-1 pattern in dual channel repeater mode.  $V_{CC} = 3.3V$ ,  $T_A = +25^\circ C$ ,  $V_{ID} = 0.5V$ ,  $V_{CM} = 1.2V$ , 0% Pre-emphasis

**Total Jitter (T<sub>J</sub>) vs. Bit Data Rate**

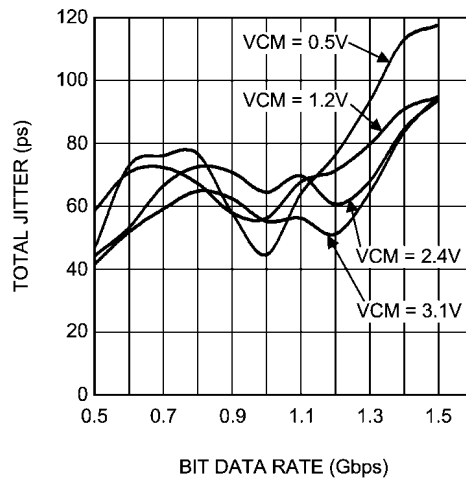

20071442

Total Jitter measured at 0V differential while running a PRBS 2<sup>23</sup>-1 pattern in single channel repeater mode.  $V_{CC} = 3.3V$ ,  $T_A = +25^\circ C$ ,  $V_{ID} = 0.5V$ , 0% Pre-emphasis

**Total Jitter (T<sub>J</sub>) vs. Temperature**

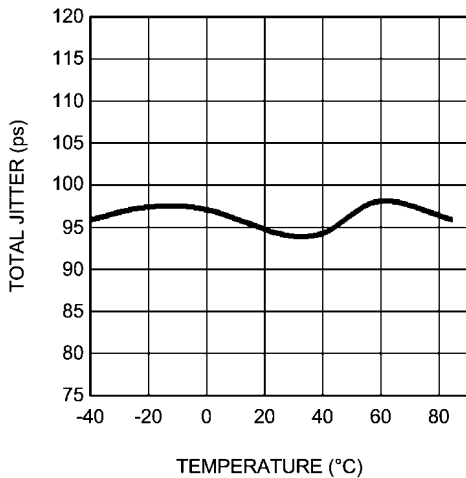

20071443

Total Jitter measured at 0V differential while running a PRBS 2<sup>23</sup>-1 pattern in dual channel repeater mode.  $V_{CC} = 3.3V$ ,  $V_{ID} = 0.5V$ ,  $V_{CM} = 1.2V$ , 1.5 Gbps data rate, 0% Pre-emphasis

**Positive Edge Transition vs. Pre-emphasis Level**

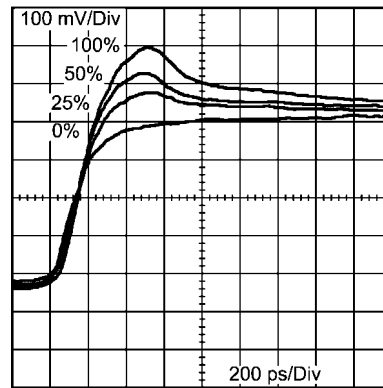

20071455

**FIGURE 7. Typical Performance Characteristics**

## Design-For-Test (DfT) Features

### IEEE 1149.1 SUPPORT

The SCAN90CP02 supports a fully compliant IEEE 1149.1 interface. The Test Access Port (TAP) provides access to boundary scan cells at each LVTTTL I/O on the device for interconnect testing. Differential pins are included in the same boundary scan chain but instead contain IEEE1149.6 cells. IEEE1149.6 is the improved IEEE standard for testing high-speed differential signals.

Refer to the BSDL file located on National's website for the details of the SCAN90CP02 IEEE 1149.1 implementation.

### IEEE 1149.6 SUPPORT

AC-coupled differential interconnections on very high speed (1+ Gbps) data paths are not testable using traditional IEEE 1149.1 techniques. The IEEE 1149.1 structures and methods are intended to test static (DC-coupled), single ended networks. IEEE1149.6 is specifically designed for testing high-speed differential, including AC coupled networks.

The SCAN90CP02 is intended for high-speed signalling up to 1.5 Gbps and includes IEEE1149.6 on all differential inputs and outputs.

### FAULT INSERTION

Fault Insertion is a technique used to assist in the verification and debug of diagnostic software. During system testing faults are "injected" to simulate hardware failure and thus help verify the monitoring software can detect and diagnose these faults. In the SCAN90004 an IEEE1149.1 "stuck-at" instruction can create a stuck-at condition, either high or low, on any pin or combination of pins.

A more detailed description of the stuck-at feature can be found in NSC Applications note AN-1313.

**Physical Dimensions** inches (millimeters) unless otherwise noted

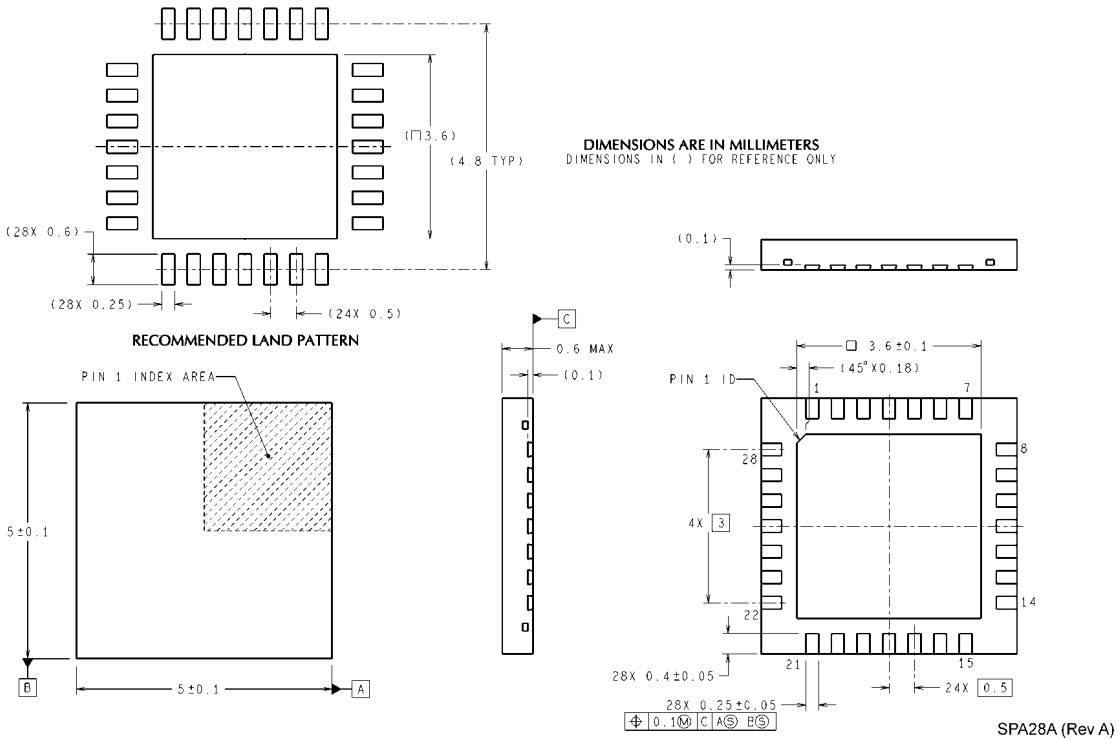

**LLP, Plastic, QUAD,**  
**Order Number SCAN90CP02SP (1000 piece Tape and Reel),**  
**SCAN90CP02SPX (4500 piece Tape and Reel)**  
**NS Package Number SPA28A**

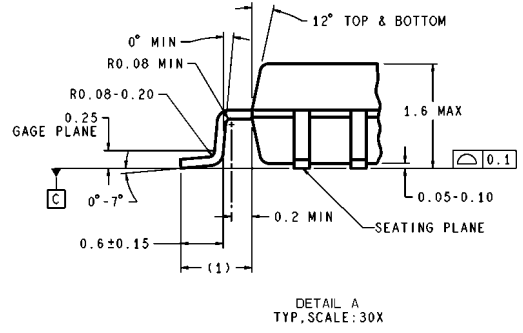
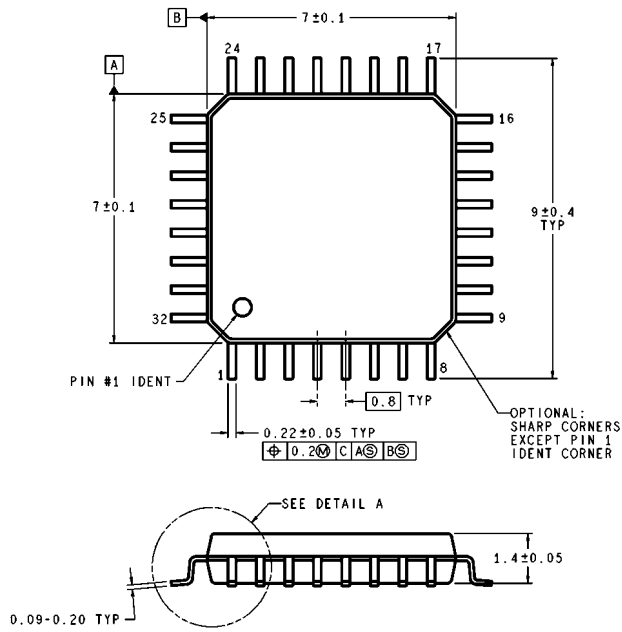

DIMENSIONS ARE IN MILLIMETERS

VBE32A (Rev E)

**LQFP, Plastic, Quad**  
**Order Number SCAN90CP02VY (250 piece Tray)**  
**SCAN90CP02VYX (1000 piece Tape and Reel)**  
**NS Package Number VBE32A**

# Notes

SCAN90CP02

## Notes

For more National Semiconductor product information and proven design tools, visit the following Web sites at:

Products		Design Support	
Amplifiers	<a href="http://www.national.com/amplifiers">www.national.com/amplifiers</a>	WEBENCH® Tools	<a href="http://www.national.com/webench">www.national.com/webench</a>
Audio	<a href="http://www.national.com/audio">www.national.com/audio</a>	App Notes	<a href="http://www.national.com/appnotes">www.national.com/appnotes</a>
Clock and Timing	<a href="http://www.national.com/timing">www.national.com/timing</a>	Reference Designs	<a href="http://www.national.com/refdesigns">www.national.com/refdesigns</a>
Data Converters	<a href="http://www.national.com/adc">www.national.com/adc</a>	Samples	<a href="http://www.national.com/samples">www.national.com/samples</a>
Interface	<a href="http://www.national.com/interface">www.national.com/interface</a>	Eval Boards	<a href="http://www.national.com/evalboards">www.national.com/evalboards</a>
LVDS	<a href="http://www.national.com/lvds">www.national.com/lvds</a>	Packaging	<a href="http://www.national.com/packaging">www.national.com/packaging</a>
Power Management	<a href="http://www.national.com/power">www.national.com/power</a>	Green Compliance	<a href="http://www.national.com/quality/green">www.national.com/quality/green</a>
Switching Regulators	<a href="http://www.national.com/switchers">www.national.com/switchers</a>	Distributors	<a href="http://www.national.com/contacts">www.national.com/contacts</a>
LDOs	<a href="http://www.national.com/ldo">www.national.com/ldo</a>	Quality and Reliability	<a href="http://www.national.com/quality">www.national.com/quality</a>
LED Lighting	<a href="http://www.national.com/led">www.national.com/led</a>	Feedback/Support	<a href="http://www.national.com/feedback">www.national.com/feedback</a>
Voltage Reference	<a href="http://www.national.com/vref">www.national.com/vref</a>	Design Made Easy	<a href="http://www.national.com/easy">www.national.com/easy</a>
PowerWise® Solutions	<a href="http://www.national.com/powerwise">www.national.com/powerwise</a>	Solutions	<a href="http://www.national.com/solutions">www.national.com/solutions</a>
Serial Digital Interface (SDI)	<a href="http://www.national.com/sdi">www.national.com/sdi</a>	Mil/Aero	<a href="http://www.national.com/milaero">www.national.com/milaero</a>
Temperature Sensors	<a href="http://www.national.com/tempsensors">www.national.com/tempsensors</a>	SolarMagic™	<a href="http://www.national.com/solarmagic">www.national.com/solarmagic</a>
Wireless (PLL/VCO)	<a href="http://www.national.com/wireless">www.national.com/wireless</a>	Analog University®	<a href="http://www.national.com/AU">www.national.com/AU</a>

THE CONTENTS OF THIS DOCUMENT ARE PROVIDED IN CONNECTION WITH NATIONAL SEMICONDUCTOR CORPORATION ("NATIONAL") PRODUCTS. NATIONAL MAKES NO REPRESENTATIONS OR WARRANTIES WITH RESPECT TO THE ACCURACY OR COMPLETENESS OF THE CONTENTS OF THIS PUBLICATION AND RESERVES THE RIGHT TO MAKE CHANGES TO SPECIFICATIONS AND PRODUCT DESCRIPTIONS AT ANY TIME WITHOUT NOTICE. NO LICENSE, WHETHER EXPRESS, IMPLIED, ARISING BY ESTOPPEL OR OTHERWISE, TO ANY INTELLECTUAL PROPERTY RIGHTS IS GRANTED BY THIS DOCUMENT.

TESTING AND OTHER QUALITY CONTROLS ARE USED TO THE EXTENT NATIONAL DEEMS NECESSARY TO SUPPORT NATIONAL'S PRODUCT WARRANTY. EXCEPT WHERE MANDATED BY GOVERNMENT REQUIREMENTS, TESTING OF ALL PARAMETERS OF EACH PRODUCT IS NOT NECESSARILY PERFORMED. NATIONAL ASSUMES NO LIABILITY FOR APPLICATIONS ASSISTANCE OR BUYER PRODUCT DESIGN. BUYERS ARE RESPONSIBLE FOR THEIR PRODUCTS AND APPLICATIONS USING NATIONAL COMPONENTS. PRIOR TO USING OR DISTRIBUTING ANY PRODUCTS THAT INCLUDE NATIONAL COMPONENTS, BUYERS SHOULD PROVIDE ADEQUATE DESIGN, TESTING AND OPERATING SAFEGUARDS.

EXCEPT AS PROVIDED IN NATIONAL'S TERMS AND CONDITIONS OF SALE FOR SUCH PRODUCTS, NATIONAL ASSUMES NO LIABILITY WHATSOEVER, AND NATIONAL DISCLAIMS ANY EXPRESS OR IMPLIED WARRANTY RELATING TO THE SALE AND/OR USE OF NATIONAL PRODUCTS INCLUDING LIABILITY OR WARRANTIES RELATING TO FITNESS FOR A PARTICULAR PURPOSE, MERCHANTABILITY, OR INFRINGEMENT OF ANY PATENT, COPYRIGHT OR OTHER INTELLECTUAL PROPERTY RIGHT.

### LIFE SUPPORT POLICY

**NATIONAL'S PRODUCTS ARE NOT AUTHORIZED FOR USE AS CRITICAL COMPONENTS IN LIFE SUPPORT DEVICES OR SYSTEMS WITHOUT THE EXPRESS PRIOR WRITTEN APPROVAL OF THE CHIEF EXECUTIVE OFFICER AND GENERAL COUNSEL OF NATIONAL SEMICONDUCTOR CORPORATION.** As used herein:

Life support devices or systems are devices which (a) are intended for surgical implant into the body, or (b) support or sustain life and whose failure to perform when properly used in accordance with instructions for use provided in the labeling can be reasonably expected to result in a significant injury to the user. A critical component is any component in a life support device or system whose failure to perform can be reasonably expected to cause the failure of the life support device or system or to affect its safety or effectiveness.

National Semiconductor and the National Semiconductor logo are registered trademarks of National Semiconductor Corporation. All other brand or product names may be trademarks or registered trademarks of their respective holders.

Copyright© 2009 National Semiconductor Corporation

For the most current product information visit us at [www.national.com](http://www.national.com)



**National Semiconductor Americas Technical Support Center**  
 Email: [support@nsc.com](mailto:support@nsc.com)  
 Tel: 1-800-272-9959

**National Semiconductor Europe Technical Support Center**  
 Email: [europe.support@nsc.com](mailto:europe.support@nsc.com)

**National Semiconductor Asia Pacific Technical Support Center**  
 Email: [ap.support@nsc.com](mailto:ap.support@nsc.com)

**National Semiconductor Japan Technical Support Center**  
 Email: [jpn.feedback@nsc.com](mailto:jpn.feedback@nsc.com)