

DS25CP104A

3.125 Gbps 4x4 LVDS Crosspoint Switch with Transmit Pre-Emphasis and Receive Equalization

General Description

The DS25CP104A is a 3.125 Gbps 4x4 LVDS crosspoint switch optimized for high-speed signal routing and switching over lossy FR-4 printed circuit board backplanes and balanced cables. Fully differential signal paths ensure exceptional signal integrity and noise immunity. The non-blocking architecture allows connections of any input to any output or outputs. The switch configuration can be accomplished via external pins or the System Management Bus (SMBus) interface.

The DS25CP104A features four levels (Off, Low, Medium, High) of transmit pre-emphasis (PE) and four levels (Off, Low, Medium, High) of receive equalization (EQ) settable via the SMBus interface. Off and Medium PE levels and Off and Low EQ levels are settable with the external pins. In addition, the SMBus circuitry enables the loss of signal (LOS) monitors that can inform a system of the presence of an open inputs condition (e.g. disconnected cable).

Wide input common mode range allows the switch to accept signals with LVDS, CML and LVPECL levels; the output levels are LVDS. A very small package footprint requires a minimal space on the board while the flow-through pinout allows easy board layout. Each differential input and output is internally terminated with a 100Ω resistor to lower return losses, reduce component count and further minimize board space.

Features

- DC - 3.125 Gbps low jitter, low skew, low power operation
- Pin and SMBus configurable, fully differential, non-blocking architecture
- Pin (two levels) and SMBus (four levels) selectable pre-emphasis and equalization eliminate ISI jitter
- Wide Input Common Mode Range enables easy interface to CML and LVPECL drivers
- $\overline{\text{LOS}}$ circuitry detects open inputs fault condition
- On-chip 100Ω input and output termination minimizes insertion and return losses, reduces component count and minimizes board space
- 8 kV ESD on LVDS I/O pins protects adjoining components
- Small 6 mm x 6 mm LLP-40 space saving package

Applications

- SD/HD/3G HD SDI Routers
- OC-48 / STM-16
- InfiniBand and FireWire

Typical Application

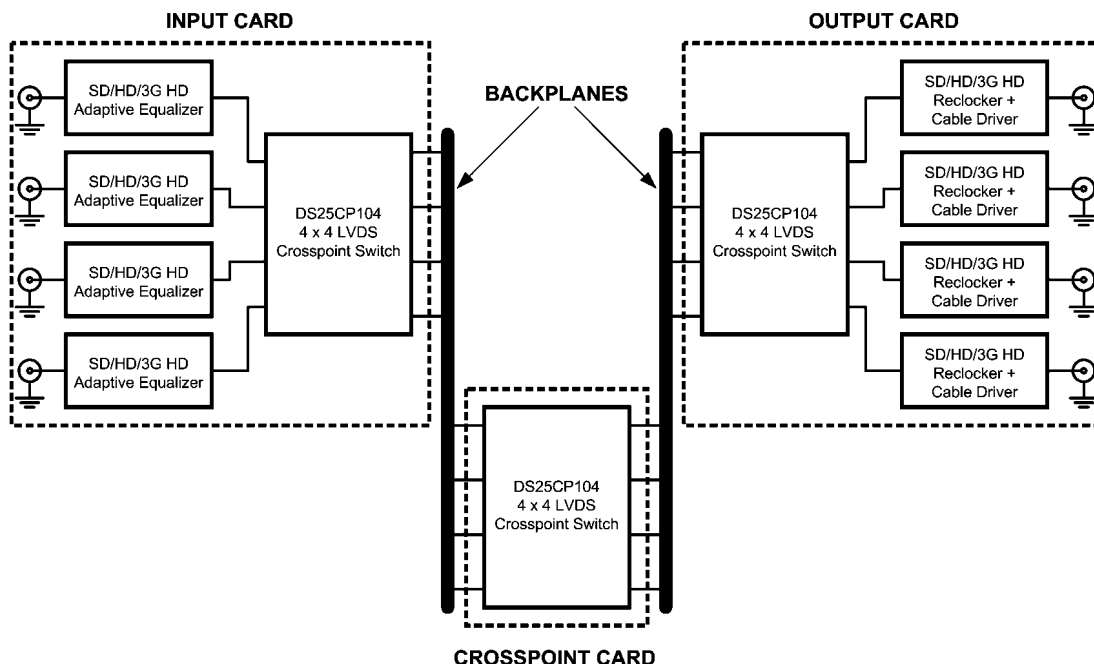

30073603

Ordering Code

NSID	Function	Available Equalization Levels	Available Pre-Emphasis Levels
DS25CP104ATSQ	Crosspoint Switch	Off / Low / Medium / High	Off / Low / Medium / High

Block Diagram

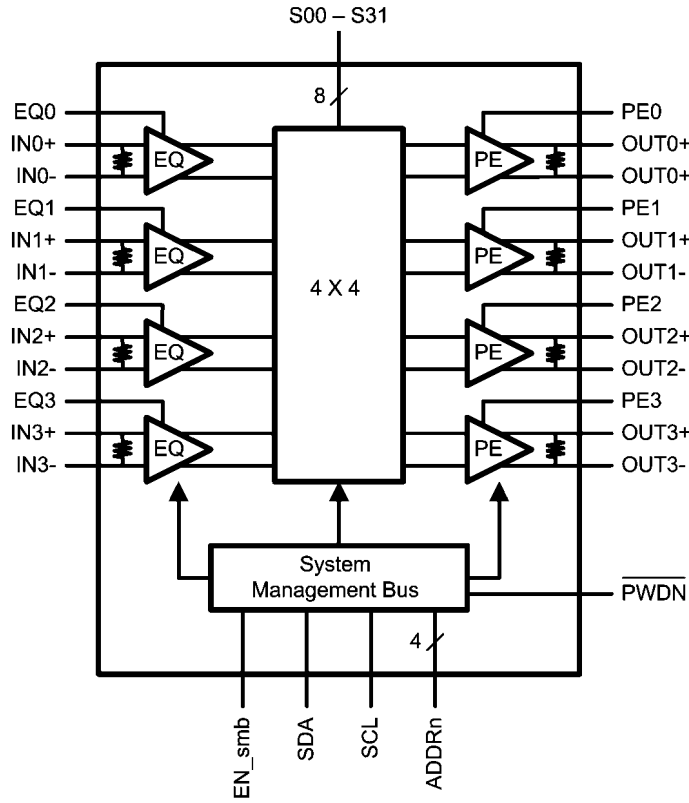

30073601

Connection Diagram

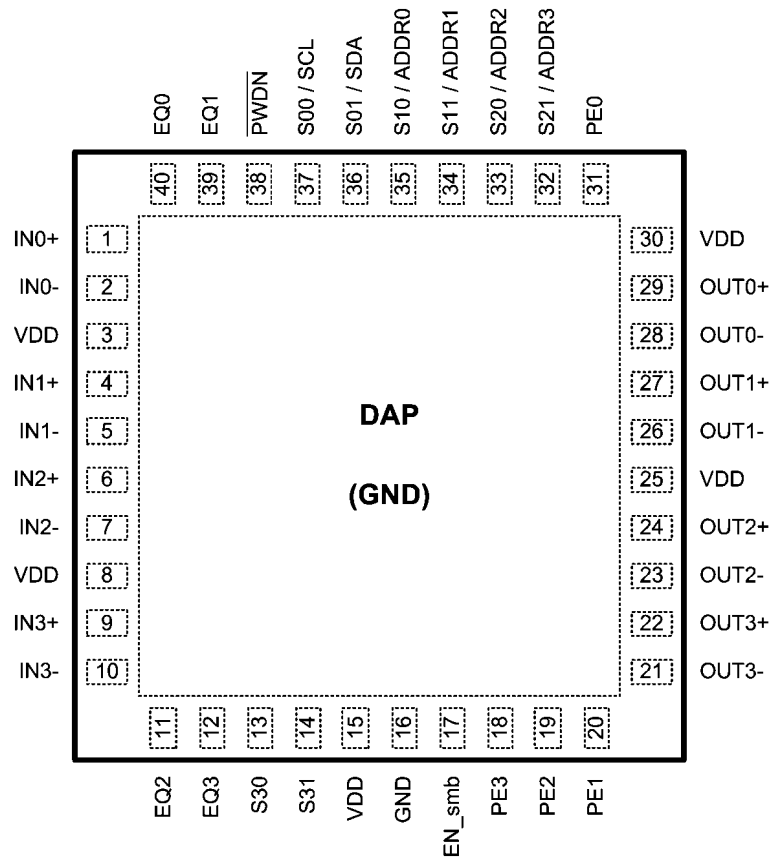

DS25CP104A Pin Diagram

30073602

Pin Descriptions

Pin Name	Pin Number	I/O, Type	Pin Description
IN0+, IN0-, IN1+, IN1-, IN2+, IN2-, IN3+, IN3-	1, 2, 4, 5, 6, 7, 9, 10	I, LVDS	Inverting and non-inverting high speed LVDS input pins.
OUT0+, OUT0-, OUT1+, OUT1-, OUT2+, OUT2-, OUT3+, OUT3-	29, 28, 27, 26, 24, 23, 22, 21	O, LVDS	Inverting and non-inverting high speed LVDS output pins.
EQ0, EQ1, EQ2, EQ3	40, 39, 11, 12	I, LVCMOS	Receive equalization level select pins. These pins are functional regardless of the EN_smb pin state.
PE0, PE1, PE2, PE3	31, 20, 19, 18	I, LVCMOS	Transmit pre-emphasis level select pins. These pins are functional regardless of the EN_smb pin state.
EN_smb	17	I, LVCMOS	System Management Bus (SMBus) enable pin. The pin has an internal pull down. When the pin is set to a [1], the device is in the SMBus mode. All SMBus registers are reset when this pin is toggled. There is a 20k pulldown device on this pin.
S00/SCL	37	I, LVCMOS	For EN_smb = [0], these pins select which LVDS input is routed to the OUT0.
S01/SDA	36	I/O, LVCMOS	In the SMBus mode, when the EN_smb = [1], these pins are SMBus clock input and data input pins respectively.
S10/ADDR0, S11/ADDR1	35, 34	I, LVCMOS	For EN_smb = [0], these pins select which LVDS input is routed to the OUT1. In the SMBus mode, when the EN_smb = [1], these pins are the User-Set SMBus Slave Address inputs.
S20/ADDR2, S21/ADDR3	33, 32	I, LVCMOS	For EN_smb = [0], these pins select which LVDS input is routed to the OUT2. In the SMBus mode, when the EN_smb = H, these pins are the User-Set SMBus Slave Address inputs.
S30, S31	13, 14	I, LVCMOS	For EN_smb = [0], these pins select which LVDS input is routed to the OUT3. In the SMBus mode, when the EN_smb = [1], these pins are non-functional and should be tied to either logic H or L.
PWDN	38	I, LVCMOS	For EN_smb = [0], this is the power down pin. When the $\overline{\text{PWDN}}$ is set to a [0], the device is in the power down mode. The SMBus circuitry can still be accessed provided the EN_smb pin is set to a [1]. In the SMBus mode, the device is powered up by either setting the $\overline{\text{PWDN}}$ pin to [1] OR by writing a [1] to the Control Register D[7] bit ($\overline{\text{SoftPWDN}}$). The device will be powered down by setting the $\overline{\text{PWDN}}$ pin to [0] AND by writing a [0] to the Control Register D[7] bit ($\overline{\text{SoftPWDN}}$).
VDD	3, 8, 15, 25, 30	Power	Power supply pins.
GND	16, DAP	Power	Ground pin and a pad (DAP - die attach pad).

Absolute Maximum Ratings (Note 4)

If Military/Aerospace specified devices are required, please contact the National Semiconductor Sales Office/Distributors for availability and specifications.

Supply Voltage	-0.3V to +4V
LVC MOS Input Voltage	-0.3V to ($V_{CC} + 0.3V$)
LVC MOS Output Voltage	-0.3V to ($V_{CC} + 0.3V$)
LVDS Input Voltage	-0.3V to +4V
LVDS Differential Input Voltage	0V to 1.0V
LVDS Output Voltage	-0.3V to ($V_{CC} + 0.3V$)
LVDS Differential Output Voltage	0V to 1.0V
LVDS Output Short Circuit Current Duration	5 ms
Junction Temperature	+150°C
Storage Temperature Range	-65°C to +150°C
Lead Temperature Range	
Soldering (4 sec.)	+260°C
Maximum Package Power Dissipation at 25°C	
SQA Package	4.65W
Derate SQA Package	37.2 mW/°C above +25°C

Package Thermal Resistance

 θ_{JA} +26.9°C/W θ_{JC} +3.8°C/W

ESD Susceptibility

HBM (Note 1) ≥8 kV

MM (Note 2) ≥250V

CDM (Note 3) ≥1250V

Note 1: Human Body Model, applicable std. JESD22-A114C**Note 2:** Machine Model, applicable std. JESD22-A115-A**Note 3:** Field Induced Charge Device Model, applicable std. JESD22-C101-C**Recommended Operating Conditions**

	Min	Typ	Max	Units
Supply Voltage (V_{CC})	3.0	3.3	3.6	V
Receiver Differential Input Voltage (V_{ID})	0		1	V
Operating Free Air Temperature (T_A)	-40	+25	+85	°C
SMBus (SDA, SCL)			3.6	V

DC Electrical Characteristics

Over recommended operating supply and temperature ranges unless otherwise specified. (Notes 5, 6, 7)

Symbol	Parameter	Conditions	Min	Typ	Max	Units
LVC MOS DC SPECIFICATIONS						
V_{IH}	High Level Input Voltage		2.0		V_{CC}	V
V_{IL}	Low Level Input Voltage		GND		0.8	V
I_{IH}	High Level Input Current	$V_{IN} = 3.6V$ $V_{CC} = 3.6V$		0	±10	µA
			EN_smb pin	40	175	250
I_{IL}	Low Level Input Current	$V_{IN} = GND$ $V_{CC} = 3.6V$		0	±10	µA
V_{CL}	Input Clamp Voltage	$I_{CL} = -18 mA$, $V_{CC} = 0V$		-0.9	-1.5	V
V_{OL}	Low Level Output Voltage	$I_{OL} = 4 mA$ SDA pin			0.4	V
LVDS INPUT DC SPECIFICATIONS						
V_{ID}	Input Differential Voltage		0		1	V
V_{TH}	Differential Input High Threshold	$V_{CM} = +0.05V$ or $V_{CC} - 0.05V$		0	+100	mV
V_{TL}	Differential Input Low Threshold		-100	0		mV
V_{CMR}	Input Common Mode Voltage Range	$V_{ID} = 100 mV$	0.05		$V_{CC} - 0.05$	V
I_{IN}	Input Current	$V_{IN} = +3.6V$ or $0V$ $V_{CC} = 3.6V$ or $0V$		±1	±10	µA
C_{IN}	Input Capacitance	Any LVDS Input Pin to GND		1.7		pF
R_{IN}	Input Termination Resistor	Between IN+ and IN-		100		Ω

Symbol	Parameter	Conditions	Min	Typ	Max	Units
LVDS OUTPUT DC SPECIFICATIONS						
V_{OD}	Differential Output Voltage	$R_L = 100\Omega$	250	350	450	mV
ΔV_{OD}	Change in Magnitude of V_{OD} for Complimentary Output States		-35		35	mV
V_{OS}	Offset Voltage	$R_L = 100\Omega$	1.05	1.2	1.375	V
ΔV_{OS}	Change in Magnitude of V_{OS} for Complimentary Output States		-35		35	mV
I_{OS}	Output Short Circuit Current (Note 8)	OUT to GND		-35	-55	mA
		OUT to V_{CC}		7	55	mA
C_{OUT}	Output Capacitance	Any LVDS Output Pin to GND		1.2		pF
R_{OUT}	Output Termination Resistor	Between OUT+ and OUT-		100		Ω
SUPPLY CURRENT						
I_{CC1}	Supply Current	$\overline{PWDN} = 0$		40	50	mA
I_{CC2}	Supply Current	$\overline{PWDN} = 1$ PE = Off, EQ = Off Broadcast (1:4) Mode		145	175	mA
I_{CC3}	Supply Current	$\overline{PWDN} = 1$ PE = Off, EQ = Off Quad Buffer (4:4) Mode		157	190	mA

Note 4: "Absolute Maximum Ratings" indicate limits beyond which damage to the device may occur, including inoperability and degradation of device reliability and/or performance. Functional operation of the device and/or non-degradation at the Absolute Maximum Ratings or other conditions beyond those indicated in the Recommended Operating Conditions is not implied. The Recommended Operating Conditions indicate conditions at which the device is functional and the device should not be operated beyond such conditions.

Note 5: The Electrical Characteristics tables list guaranteed specifications under the listed Recommended Operating Conditions except as otherwise modified or specified by the Electrical Characteristics Conditions and/or Notes. Typical specifications are estimations only and are not guaranteed.

Note 6: Current into device pins is defined as positive. Current out of device pins is defined as negative. All voltages are referenced to ground except V_{OD} and ΔV_{OD} .

Note 7: Typical values represent most likely parametric norms for $V_{CC} = +3.3V$ and $T_A = +25^\circ C$, and at the Recommended Operation Conditions at the time of product characterization and are not guaranteed.

Note 8: Output short circuit current (I_{OS}) is specified as magnitude only, minus sign indicates direction only.

AC Electrical Characteristics

Over recommended operating supply and temperature ranges unless otherwise specified. (Notes 9, 10)

Symbol	Parameter	Conditions	Min	Typ	Max	Units	
LVDS OUTPUT AC SPECIFICATIONS (Note 11)							
t_{PLHD}	Differential Propagation Delay Low to High	$R_L = 100\Omega$		480	650	ps	
t_{PHLD}	Differential Propagation Delay High to Low			460	650	ps	
t_{SKD1}	Pulse Skew $ t_{PLHD} - t_{PHLD} $, (Note 12)			20	100	ps	
t_{SKD2}	Channel to Channel Skew, (Note 13)			40	125	ps	
t_{SKD3}	Part to Part Skew, (Note 14)			50	200	ps	
t_{LHT}	Rise Time	$R_L = 100\Omega$		80	150	ps	
t_{HLT}	Fall Time			80	150	ps	
t_{ON}	Power Up Time	Time from $\overline{PWDN} = LH$ to $OUTn$ active		6	20	μs	
t_{OFF}	Power Down Time	Time from $\overline{PWDN} = HL$ to $OUTn$ inactive		8	25	ns	
t_{SEL}	Select Time	Time from $S_n = LH$ or HL to new signal at $OUTn$		8	12	ns	
JITTER PERFORMANCE WITH EQ = Off, PE = Off (Note 11)(Figure 5)							
t_{RJ1}	Random Jitter (RMS Value)	$V_{ID} = 350\text{ mV}$ $V_{CM} = 1.2\text{V}$ Clock (RZ)	1.25 GHz		0.5	1.1	ps
t_{RJ2}	No Test Channels (Note 15)		1.5625 GHz		0.5	1.1	ps
t_{DJ1}	Deterministic Jitter (Peak to Peak)	$V_{ID} = 350\text{ mV}$ $V_{CM} = 1.2\text{V}$ K28.5 (NRZ)	2.5 Gbps		10	22	ps
t_{DJ2}	No Test Channels (Note 16)		3.125 Gbps		10	27	ps
t_{TJ1}	Total Jitter (Peak to Peak)	$V_{ID} = 350\text{ mV}$ $V_{CM} = 1.2\text{V}$ PRBS-23 (NRZ)	2.5 Gbps		0.07	0.11	UI_{P-P}
t_{TJ2}	No Test Channels (Note 17)		3.125 Gbps		0.13	0.16	UI_{P-P}

Symbol	Parameter	Conditions	Min	Typ	Max	Units	
JITTER PERFORMANCE WITH EQ = Off, PE = Low (Note 11) (<i>Figure 6 Figure 9</i>)							
t_{RJ1A}	Random Jitter (RMS Value)	$V_{ID} = 350\text{ mV}$	1.25 GHz		0.5	1.1	ps
t_{RJ2A}	Test Channels A (Note 15)	$V_{CM} = 1.2\text{V}$ Clock (RZ)	1.5625 GHz		0.5	1.1	ps
t_{DJ1A}	Deterministic Jitter (Peak to Peak)	$V_{ID} = 350\text{ mV}$	2.5 Gbps		10	22	ps
t_{DJ2A}	Test Channels A (Note 16)	$V_{CM} = 1.2\text{V}$ K28.5 (NRZ)	3.125 Gbps		10	27	ps
JITTER PERFORMANCE WITH EQ = Off, PE = Medium (Note 11) (<i>Figure 6 Figure 9</i>)							
t_{RJ1B}	Random Jitter (RMS Value)	$V_{ID} = 350\text{ mV}$	1.25 GHz		0.5	1.1	ps
t_{RJ2B}	Test Channels B (Note 15)	$V_{CM} = 1.2\text{V}$ Clock (RZ)	1.5625 GHz		0.5	1.1	ps
t_{DJ1B}	Deterministic Jitter (Peak to Peak)	$V_{ID} = 350\text{ mV}$	2.5 Gbps		12	30	ps
t_{DJ2B}	Test Channels B (Note 16)	$V_{CM} = 1.2\text{V}$ K28.5 (NRZ)	3.125 Gbps		12	30	ps
t_{TJ1B}	Total Jitter (Peak to Peak)	$V_{ID} = 350\text{ mV}$	2.5 Gbps		0.08	0.10	UI_{P-P}
t_{TJ2B}	Test Channels B (Note 17)	$V_{CM} = 1.2\text{V}$ PRBS-23 (NRZ)	3.125 Gbps		0.10	0.15	UI_{P-P}
JITTER PERFORMANCE WITH EQ = Off, PE = High (Note 11) (<i>Figures 6, 9</i>)							
t_{RJ1C}	Random Jitter (RMS Value)	$V_{ID} = 350\text{ mV}$	1.25 GHz		0.5	1.1	ps
t_{RJ2C}	Test Channels C (Note 15)	$V_{CM} = 1.2\text{V}$ Clock (RZ)	1.5625 GHz		0.5	1.1	ps
t_{DJ1C}	Deterministic Jitter (Peak to Peak)	$V_{ID} = 350\text{ mV}$	2.5 Gbps		30	60	ps
t_{DJ2C}	Test Channels C (Note 16)	$V_{CM} = 1.2\text{V}$ K28.5 (NRZ)	3.125 Gbps		30	65	ps

Symbol	Parameter	Conditions	Min	Typ	Max	Units
JITTER PERFORMANCE WITH PE = Off, EQ = Low (Note 11) (Figure 7 Figure 9)						
t_{RJ1D}	Random Jitter (RMS Value)	$V_{ID} = 350\text{ mV}$	1.25 GHz		0.5	1.1 ps
t_{RJ2D}	Test Channels D (Note 15)	$V_{CM} = 1.2\text{V}$ Clock (RZ)	1.5625 GHz		0.5	1.1 ps
t_{DJ1D}	Deterministic Jitter (Peak to Peak)	$V_{ID} = 350\text{ mV}$	2.5 Gbps		20	40 ps
t_{DJ2D}	Test Channels D (Note 16)	$V_{CM} = 1.2\text{V}$ K28.5 (NRZ)	3.125 Gbps		20	40 ps
t_{TJ1D}	Total Jitter (Peak to Peak)	$V_{ID} = 350\text{ mV}$	2.5 Gbps		0.08	0.15 $U_{I_{P-P}}$
t_{TJ2D}	Test Channels D (Note 17)	$V_{CM} = 1.2\text{V}$ PRBS-23 (NRZ)	3.125 Gbps		0.09	0.20 $U_{I_{P-P}}$
JITTER PERFORMANCE WITH PE = Off, EQ = Medium (Note 11) (Figures 7, 9)						
t_{RJ1E}	Random Jitter (RMS Value)	$V_{ID} = 350\text{ mV}$	1.25 GHz		0.5	1.1 ps
t_{RJ2E}	Test Channels E (Note 15)	$V_{CM} = 1.2\text{V}$ Clock (RZ)	1.5625 GHz		0.5	1.1 ps
t_{DJ1E}	Residual Deterministic Jitter (Peak to Peak)	$V_{ID} = 350\text{ mV}$	2.5 Gbps		35	60 ps
t_{DJ2E}	Test Channels E (Note 16)	$V_{CM} = 1.2\text{V}$ K28.5 (NRZ)	3.125 Gbps		28	55 ps
JITTER PERFORMANCE WITH PE = Off, EQ = High (Note 11) (Figures 7, 9)						
t_{RJ1F}	Random Jitter (RMS Value)	$V_{ID} = 350\text{ mV}$	1.25 GHz		1.3	1.8 ps
t_{RJ2F}	Test Channels F (Note 15)	$V_{CM} = 1.2\text{V}$ Clock (RZ)	1.5625 GHz		1.4	2.4 ps
t_{DJ1F}	Residual Deterministic Jitter (Peak to Peak)	$V_{ID} = 350\text{ mV}$	2.5 Gbps		30	75 ps
t_{DJ2F}	Test Channels F (Note 16)	$V_{CM} = 1.2\text{V}$ K28.5 (NRZ)	3.125 Gbps		35	90 ps
JITTER PERFORMANCE WITH PE = Medium, EQ = Low (Note 11) (Figures 7, 9)						
t_{RJ1G}	Random Jitter (RMS Value)	$V_{ID} = 350\text{ mV}$	1.25 GHz		0.5	1.1 ps
t_{RJ2G}	Input Test Channels D Output Test Channels B (Note 15)	$V_{CM} = 1.2\text{V}$ Clock (RZ)	1.5625 GHz		0.5	1.1 ps
t_{DJ1G}	Deterministic Jitter (Peak to Peak)	$V_{ID} = 350\text{ mV}$	2.5 Gbps		25	ps
t_{DJ2G}	Input Test Channels D Output Test Channels B (Note 16)	$V_{CM} = 1.2\text{V}$ K28.5 (NRZ)	3.125 Gbps		20	ps

Symbol	Parameter	Conditions	Min	Typ	Max	Units
SMBus AC SPECIFICATIONS						
f_{SMB}	SMBus Operating Frequency		10		100	kHz
t_{BUF}	Bus free time between Stop and Start Conditions		4.7			μ s
$t_{HD:SDA}$	Hold time after (Repeated) Start Condition. After this period, the first clock is generated.		4.0			μ s
$t_{SU:SDA}$	Repeated Start Condition setup time.		4.7			μ s
$t_{SU:SDO}$	Stop Condition setup time		4.0			μ s
$t_{HD:DAT}$	Data hold time		300			ns
$t_{SU:DAT}$	Data setup time		250			ns
$t_{TIMEOUT}$	Detect clock low timeout		25		35	ms
t_{LOW}	Clock low period		4.7			μ s
t_{HIGH}	Clock high period		4.0		50	μ s
t_{POR}	Time in which a device must be operational after power-on reset				500	ms

Note 9: The Electrical Characteristics tables list guaranteed specifications under the listed Recommended Operating Conditions except as otherwise modified or specified by the Electrical Characteristics Conditions and/or Notes. Typical specifications are estimations only and are not guaranteed.

Note 10: Typical values represent most likely parametric norms for $V_{CC} = +3.3V$ and $T_A = +25^{\circ}C$, and at the Recommended Operation Conditions at the time of product characterization and are not guaranteed.

Note 11: Specification is guaranteed by characterization and is not tested in production.

Note 12: t_{SKD1} , $|t_{PLHD} - t_{PHLD}|$, Pulse Skew, is the magnitude difference in differential propagation delay time between the positive going edge and the negative going edge of the same channel.

Note 13: t_{SKD2} , Channel to Channel Skew, is the difference in propagation delay (t_{PLHD} or t_{PHLD}) among all output channels in Broadcast mode (any one input to all outputs).

Note 14: t_{SKD3} , Part to Part Skew, is defined as the difference between the same signal path of any two devices running at the same V_{CC} and within $5^{\circ}C$ of each other within the operating temperature range.

Note 15: Measured on a clock edge with a histogram and an accumulation of 1500 histogram hits. Input stimulus jitter is subtracted geometrically.

Note 16: Tested with a combination of the 110000101 (K28.5+ character) and 0011111010 (K28.5- character) patterns. Input stimulus jitter is subtracted algebraically.

Note 17: Measured on an eye diagram with a histogram and an accumulation of 3500 histogram hits. Input stimulus jitter is subtracted.

DC Test Circuits

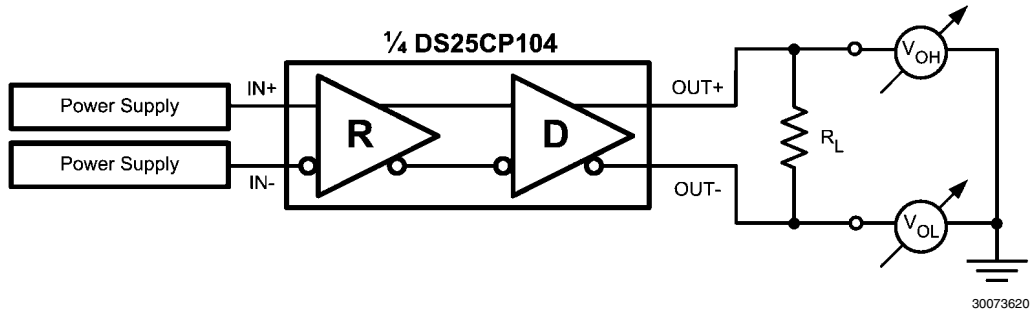

FIGURE 1. Differential Driver DC Test Circuit

AC Test Circuits and Timing Diagrams

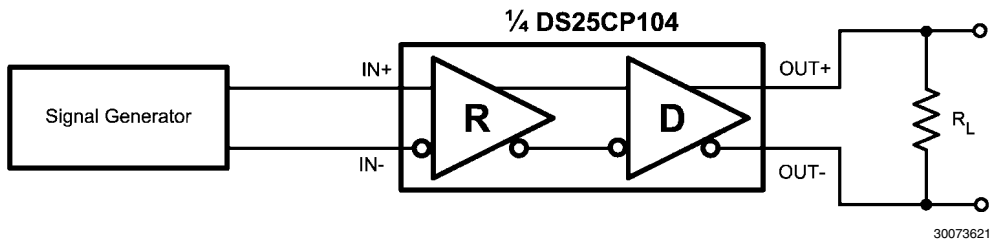

FIGURE 2. Differential Driver AC Test Circuit

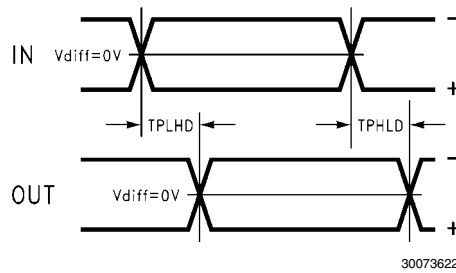

FIGURE 3. Propagation Delay Timing Diagram

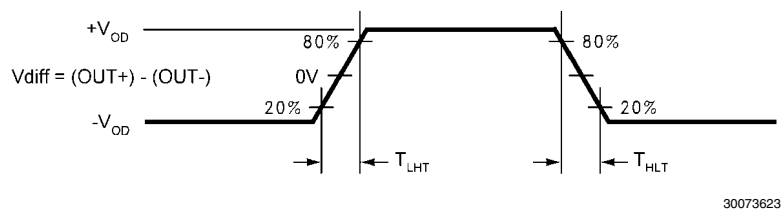
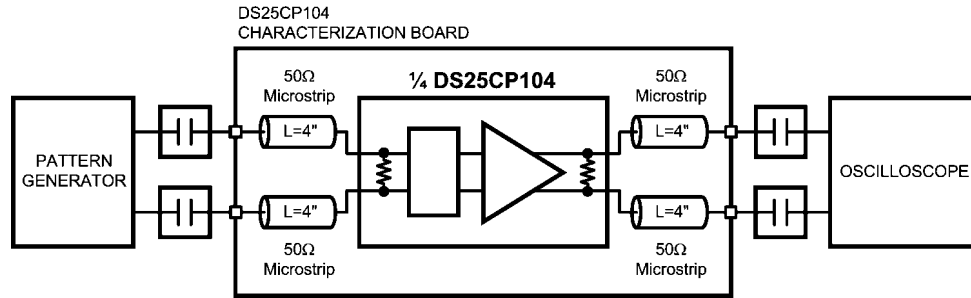

FIGURE 4. LVDS Output Transition Times

Pre-Emphasis and Equalization Test Circuits



30073629

FIGURE 5. Jitter Performance Test Circuit

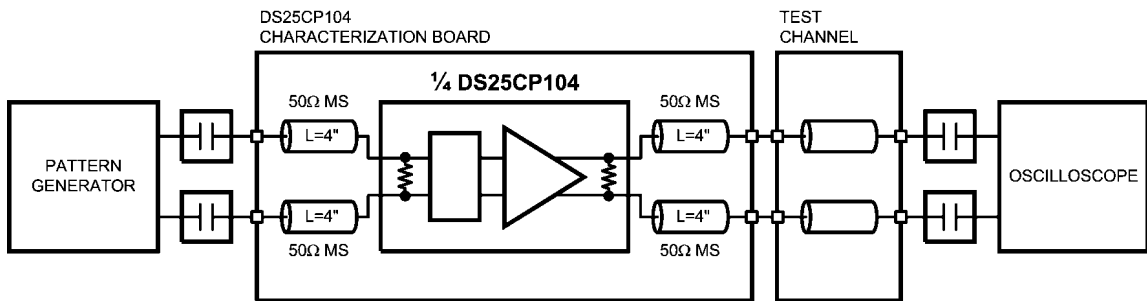

30073627

FIGURE 6. Pre-Emphasis Performance Test Circuit

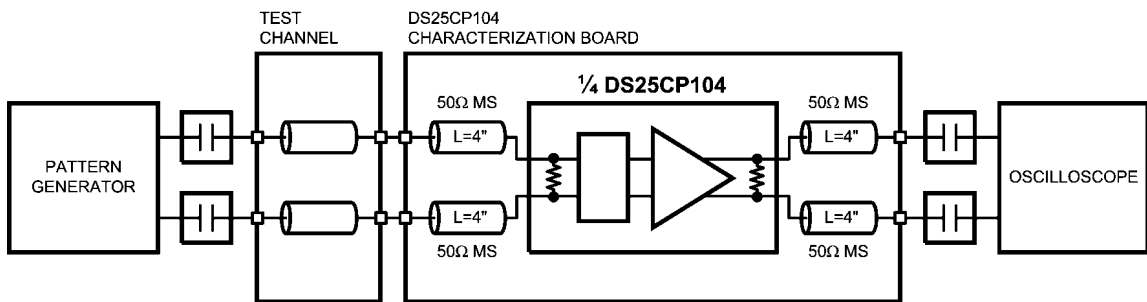

30073626

FIGURE 7. Equalization Performance Test Circuit

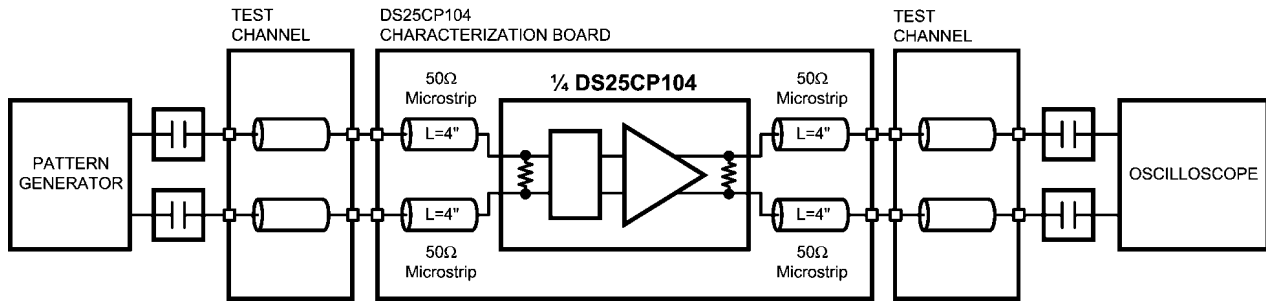

30073630

FIGURE 8. Pre-Emphasis and Equalization Performance Test Circuit

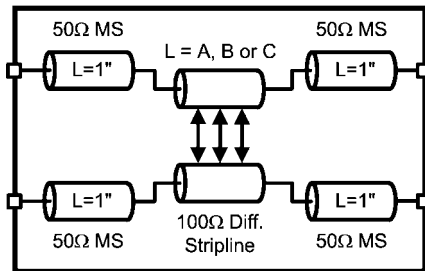

30073628

FIGURE 9. Test Channel Block Diagram

Test Channel Loss Characteristics

The test channel was fabricated with Polyclad PCL-FR-370-Laminate/PCL-FRP-370 Prepreg materials (Dielectric constant of 3.7 and Loss Tangent of 0.02). The edge coupled differential striplines have the following geometries: Trace Width (W) = 5 mils, Gap (S) = 5 mils, Height (B) = 16 mils.

Test Channel	Length (inches)	Insertion Loss (dB)					
		500 MHz	750 MHz	1000 MHz	1250 MHz	1500 MHz	1560 MHz
A	10	-1.2	-1.7	-2.0	-2.4	-2.7	-2.8
B	20	-2.6	-3.5	-4.1	-4.8	-5.5	-5.6
C	30	-4.3	-5.7	-7.0	-8.2	-9.4	-9.7
D	15	-1.6	-2.2	-2.7	-3.2	-3.7	-3.8
E	30	-3.4	-4.5	-5.6	-6.6	-7.7	-7.9
F	60	-7.8	-10.3	-12.4	-14.5	-16.6	-17.0

Functional Description

The DS25CP104A is a 3.125 Gbps 4x4 LVDS digital crosspoint switch optimized for high-speed signal routing and switching over lossy FR-4 printed circuit board backplanes and balanced cables. The DS25CP104A operates in two modes: Pin Mode (EN_smb = 0) and SMBus Mode (EN_smb = 1).

When in the Pin Mode, the switch is fully configurable with external pins. This is possible with two input select pins per output (e.g. S00 and S01 pins for OUT0). There is also one transmit pre-emphasis (PE) level select pin per output for switching the PE levels between Medium and Off settings and one receive equalization (EQ) level select pin per input for switching the EQ levels between Low and Off settings.

In the Pin Mode, feedback from the $\overline{\text{LOS}}$ (Loss Of Signal) monitor circuitry is not available (there is not an $\overline{\text{LOS}}$ output pin).

When in the SMBus Mode, the full switch configuration, four levels of transmit pre-emphasis (Off, Low, Medium and High), four levels of receive equalization (Off, Low, Medium and High) and $\text{SoftP\overline{W}DN}$ can be programmed via the SMBus interface. In addition, by using the SMBus interface, a user can obtain the feedback from the built-in $\overline{\text{LOS}}$ circuitry which detects an open inputs fault condition.

Switch Configuration Truth Tables

TABLE 1. Input Select Pins Configuration for the Output OUT0

S01	S00	INPUT SELECTED
0	0	IN0
0	1	IN1
1	0	IN2
1	1	IN3

TABLE 2. Input Select Pins Configuration for the Output OUT1

S11	S10	INPUT SELECTED
0	0	IN0
0	1	IN1
1	0	IN2
1	1	IN3

In the SMBus Mode, the S00 and S01 pins become SMBus clock (SCL) input and data (SDA) input pins respectively; the S10, S11, S21 and S21 pins become the User-Set SMBus Slave Address input pins (ADDR0, 1, 2 and 3) while the S30 and S31 pins become non-functional (tying these two pins to either H or L is recommended if the device will function only in the SMBus mode).

In the SMBus Mode, the PE and EQ select pins as well as the $\overline{\text{P\overline{W}DN}}$ pin remain functional. How these pins function in each mode is explained in the following sections.

DS25CP104A OPERATION IN THE PIN MODE

Power Up

In the Pin Mode, when the power is applied to the device power supply pins, the DS25CP104A enters the Power Up mode when the $\overline{\text{P\overline{W}DN}}$ pin is set to logic H. When in the Power Down mode ($\overline{\text{P\overline{W}DN}}$ pin is set to logic L), all circuitry is shut down except the minimum required circuitry for the $\overline{\text{LOS}}$ and SMBus Slave operation.

Switch Configuration

In the Pin Mode, the DS25CP104A operates as a fully pin-configurable crosspoint switch. The following truth tables illustrate how the switch can be configured with external pins.

TABLE 3. Input Select Pins Configuration for the Output OUT2

S21	S20	INPUT SELECTED
0	0	IN0
0	1	IN1
1	0	IN2
1	1	IN3

TABLE 4. Input Select Pins Configuration for the Output OUT3

S31	S30	INPUT SELECTED
0	0	IN0
0	1	IN1
1	0	IN2
1	1	IN3

Setting Pre-Emphasis Levels

The DS25CP104A has one PE level select pin per output for setting the transmit pre-emphasis to either Medium or Off level. The following is the transmit pre-emphasis truth table.

TABLE 5. Transmit Pre-Emphasis Truth Table

OUTPUT OUT _n , n = {0, 1, 2, 3}	
Pre-Emphasis Control Pin (PE _n) State	Pre-Emphasis Level
0	Off
1	Medium

Transmit Pre-emphasis Level Selection for an Output OUT_n

Setting Equalization Levels

The DS25CP104A has one EQ level select pin per input for setting the receive equalization to either Low or Off level. The following is the receive equalization truth table.

TABLE 6. Receive Equalization Truth Table

INPUT IN _n , n = {0, 1, 2, 3}	
Equalization Control Pin (EQ _n) State	Equalization Level
0	Off
1	Low

Receive Equalization Level Selection for an Input IN_n

DS25CP104A OPERATION IN THE SMBUS MODE

The DS25CP104A operates as a slave on the System Management Bus (SMBus) when the EN_smb pin is set to a high (1). Under these conditions, the SCL pin is a clock input while the SDA pin is a serial data input pin.

Device Address

Based on the SMBus 2.0 specification, the DS25CP104A has a 7-bit slave address. The three most significant bits of the

slave address are hard wired inside the DS25CP104A and are "101". The four least significant bits of the address are assigned to pins ADDR3-ADDR0 and are set by connecting these pins to GND for a low (0) or to VCC for a high (1). The complete slave address is shown in the following table:

TABLE 7. DS25CP104A Slave Address

1	0	1	ADDR3	ADDR2	ADDR1	ADDR0
MSB						LSB

This slave address configuration allows up to sixteen DS25CP104A devices on a single SMBus bus.

Transfer of Data via the SMBus

During normal operation the data on SDA must be stable during the time when SCK is high.

There are three unique states for the SMBus:

START: A HIGH to LOW transition on SDA while SCK is high indicates a message START condition.

STOP: A LOW to HIGH transition on SDA while SCK is high indicates a message STOP condition.

IDLE: If SCK and SDA are both high for a time exceeding tBUF from the last detected STOP condition or if they are high for a total exceeding the maximum specification for tHIGH then the bus will transfer to the IDLE state.

SMBus Transactions

A transaction begins with the host placing the DS25CP104A SMBus into the START condition, then a byte (8 bits) is transferred, MSB first, followed by a ninth ACK bit. ACK bits are '0' to signify an ACK, or '1' to signify NACK, after this the host holds the SCL line low, and waits for the receiver to raise the SDA line as an ACKnowledge that the byte has been received.

Writing to a Register

To write a register, the following protocol is used (see SMBus 2.0 specification):

1) The Host drives a START condition, the 7-bit SMBus address, and a "0" indicating a WRITE.

2) The Device (Slave) drives an ACK bit ("0").

3) The Host drives the 8-bit Register Address.

4) The Device drives an ACK bit ("0").

5) The Host drives the 8-bit data byte.

6) The Device drives an ACK bit "0".

7) The Host drives a STOP condition.

The WRITE transaction is completed, the bus goes Idle and communication with other SMBus devices may now occur.

Reading From a Register

To read a register, the following protocol is used (see SMBus 2.0 specification):

1) The Host drives a START condition, the 7-bit SMBus address, and a "0" indicating a WRITE.

2) The Device (Slave) drives an ACK bit ("0").

3) The Host drives the 8-bit Register Address.

4) The Device drives an ACK bit ("0").

5) The Host drives a START condition.

6) The Host drives the 7-bit SMBus Address, and a "1" indicating a READ.

7) The Device drives an ACK bit "0".

8) The Device drives the 8-bit data value (register contents).

9) The Host drives a NACK bit "1" indicating end of READ transfer.

10) The Host drives a STOP condition.

The READ transaction is completed, the bus goes Idle and communication with other SMBus devices may now occur.

Register Descriptions

There are five data registers in the DS25CP104A accessible via the SMBus interface.

TABLE 8. DS25CP104A SMBus Data Registers

Address (hex)	Name	Access	Description
0	Switch Configuration	R/W	Switch Configuration Register
1	PE Level Select	R/W	Transmit Pre-emphasis Level Select Register
2	EQ Level Select	R/W	Receive Equalization Level Select Register
3	Control	R/W	Powerdown, $\overline{\text{LOS}}$ Enable and Pin Control Register
4	$\overline{\text{LOS}}$	RO	Loss Of Signal ($\overline{\text{LOS}}$) Reporting Register

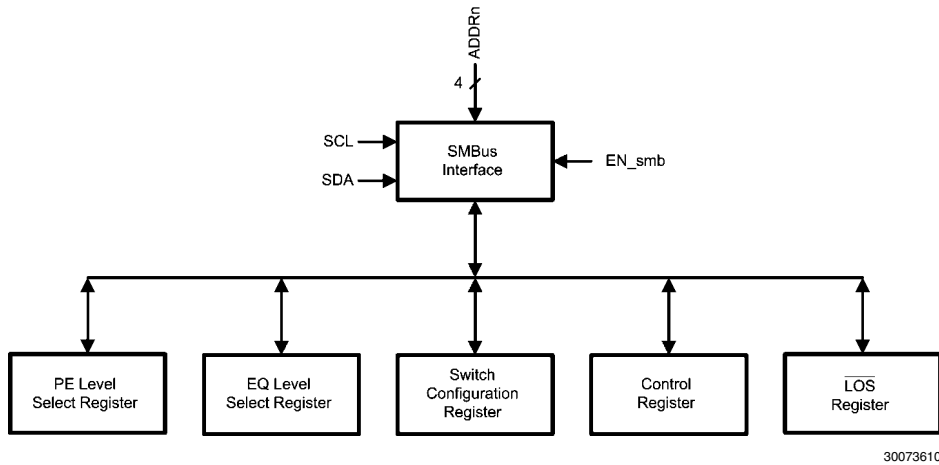

FIGURE 10. DS25CP104A Registers Block Diagram

SWITCH CONFIGURATION REGISTER

The Switch Configuration register is utilized to configure the switch. The following two tables show the Switch Configuration Register mapping and associated truth table.

Bit	Default	Bit Name	Access	Description
D[1:0]	00	Input Select 0	R/W	Selects which input is routed to the OUT0.
D[3:2]	00	Input Select 1	R/W	Selects which input is routed to the OUT1.
D[5:4]	00	Input Select 2	R/W	Selects which input is routed to the OUT2.
D[7:6]	00	Input Select 3	R/W	Selects which input is routed to the OUT3.

TABLE 9. Switch Configuration Register Truth Table

D1	D0	Input Routed to the OUT0
0	0	IN0
0	1	IN1
1	0	IN2
1	1	IN3

The truth tables for the OUT1, OUT2, and OUT3 outputs are identical to this table.

The switch configuration logic has a SmartPWDN circuitry which automatically optimizes the device's power consumption based on the switch configuration (i.e. It places unused I/O blocks and other unused circuitry in the power down state).

PE LEVEL SELECT REGISTER

The PE Level Select register selects the pre-emphasis level for each of the outputs. The following two tables show the register mapping and associated truth table.

Bit	Default	Bit Name	Access	Description
D[1:0]	00	PE Level Select 0	R/W	Sets pre-emphasis level on the OUT0.
D[3:2]	00	PE Level Select 1	R/W	Sets pre-emphasis level on the OUT1.
D[5:4]	00	PE Level Select 2	R/W	Sets pre-emphasis level on the OUT2.
D[7:6]	00	PE Level Select 3	R/W	Sets pre-emphasis level on the OUT3.

TABLE 10. PE Level Select Register Truth Table

D1	D0	Pre-Emphasis Level for the OUT0
0	0	Off
0	1	Low
1	0	Medium
1	1	High

NOTE: The truth tables for the OUT1, OUT2, and OUT3 outputs are identical to this table.

EQ LEVEL SELECT REGISTER

The EQ Level Select register selects the equalization level for each of the inputs. The following two tables show the register mapping and associated truth table.

Bit	Default	Bit Name	Access	Description
D[1:0]	00	EQ Level Select 0	R/W	Sets equalization level on the IN0.
D[3:2]	00	EQ Level Select 1	R/W	Sets equalization level on the IN1.
D[5:4]	00	EQ Level Select 2	R/W	Sets equalization level on the IN2.
D[7:6]	00	EQ Level Select 3	R/W	Sets equalization level on the IN3.

TABLE 11. EQ Level Select Register Truth Table

D1	D0	Equalization Level for the IN0
0	0	Off
0	1	Low
1	0	Medium
1	1	High

NOTE: The truth tables for the IN1, IN2, and IN3 outputs are identical to this table.

CONTROL REGISTER

The Control register enables $\overline{\text{SoftPWN}}$ control, individual output power down ($\overline{\text{PWNn}}$) control, $\overline{\text{LOS}}$ Circuitry Enable control, PE Level Select Enable control and EQ Level Select Enable control via the SMBus. The following table shows the register mapping.

Bit	Default	Bit Name	Access	Description
D[3:0]	1111	$\overline{\text{PWNn}}$	R/W	Writing a [0] to the bit D[n] will power down the output OUTn when either the $\overline{\text{PWN}}$ pin OR the Control Register bit D[7] ($\overline{\text{SoftPWN}}$) is set to a high [1].
D[4]	0	Ignore_External_EQ	R/W	Writing a [1] to the bit D[4] will ignore the state of the external EQ pins and will allow setting the EQ levels via the SMBus interface.
D[5]	0	Ignore_External_PE	R/W	Writing a [1] to the bit D[5] will ignore the state of the external PE pins and will allow setting the PE levels via the SMBus interface.
D[6]	0	EN_ $\overline{\text{LOS}}$	R/W	Writing a [1] to the bit D[6] will enable the $\overline{\text{LOS}}$ circuitry and receivers on all four inputs. The SmartPWN circuitry will not disable any of the inputs nor any supporting $\overline{\text{LOS}}$ circuitry depending on the switch configuration.
D[7]	0	$\overline{\text{SoftPWN}}$	R/W	Writing a [0] to the bit D[7] will place the device into the power down mode. This pin is ORed together with the $\overline{\text{PWN}}$ pin.

TABLE 12. DS25CP104A Power Modes Truth Table

$\overline{\text{PWN}}$	$\overline{\text{SoftPWN}}$	$\overline{\text{PWNn}}$	DS25CP104A Power Mode
0	0	x	Power Down Mode. In this mode, all circuitry is shut down except the minimum required circuitry for the $\overline{\text{LOS}}$ and SMBus Slave operation. The SMBus circuitry allows enabling the $\overline{\text{LOS}}$ circuitry and receivers on all inputs in this mode by setting the EN_ $\overline{\text{LOS}}$ bit to a [1].
0	1	x	Power Up Mode. In this mode, the SmartPWN circuitry will automatically power down any unused I/O and logic blocks and other supporting circuitry depending on the switch configuration. An output will be enabled only when the SmartPWN circuitry indicates that that particular output is needed for the particular switch configuration and the respective $\overline{\text{PWNn}}$ bit has logic high [1]. An input will be enabled when the SmartPWN circuitry indicates that that particular input is needed for the particular switch configuration or the EN_ $\overline{\text{LOS}}$ bit is set to a [1].
1	0	x	
1	1	x	

 $\overline{\text{LOS}}$ REGISTER

The $\overline{\text{LOS}}$ register reports an open inputs fault condition for each of the inputs. The following table shows the register mapping.

Bit	Default	Bit Name	Access	Description
D[0]	0	$\overline{\text{LOS0}}$	RO	Reading a [0] from the bit D[0] indicates an open inputs fault condition on the IN0. A [1] indicates presence of a valid signal.
D[1]	0	$\overline{\text{LOS1}}$	RO	Reading a [0] from the bit D[1] indicates an open inputs fault condition on the IN1. A [1] indicates presence of a valid signal.
D[2]	0	$\overline{\text{LOS2}}$	RO	Reading a [0] from the bit D[2] indicates an open inputs fault condition on the IN2. A [1] indicates presence of a valid signal.
D[3]	0	$\overline{\text{LOS3}}$	RO	Reading a [0] from the bit D[3] indicates an open inputs fault condition on the IN3. A [1] indicates presence of a valid signal.
D[7:4]	0000	Reserved	RO	Reserved for future use. Returns undefined value when read.

INPUT INTERFACING

The DS25CP104A accepts differential signals and allows simple AC or DC coupling. With a wide common mode range, the DS25CP104A can be DC-coupled with all common dif-

ferential drivers (i.e. LVPECL, LVDS, CML). The following three figures illustrate typical DC-coupled interface to common differential drivers. Note that the DS25CP104A inputs are internally terminated with a 100Ω resistor.

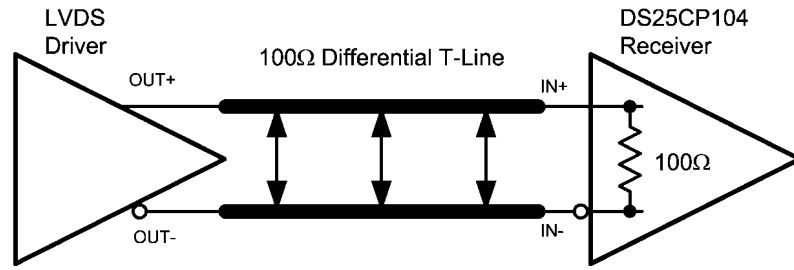

Typical LVDS Driver DC-Coupled Interface to DS25CP104A Input

30073631

CML3.3V or CML2.5V Driver

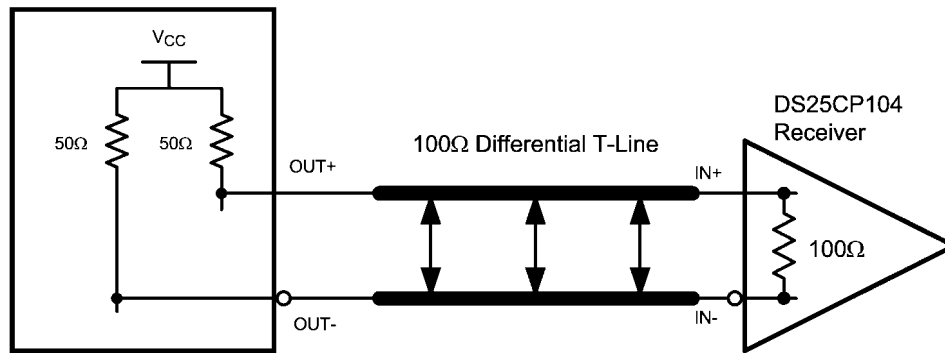

Typical CML Driver DC-Coupled Interface to DS25CP104A Input

30073632

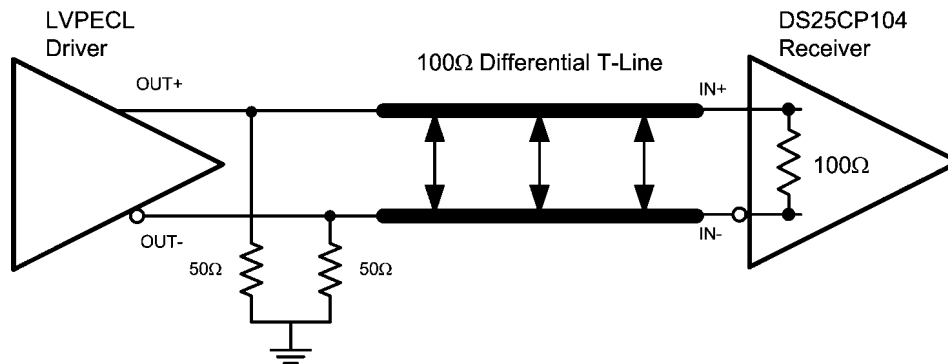

Typical LVPECL Driver DC-Coupled Interface to DS25CP104A Input

30073633

OUTPUT INTERFACING

The DS25CP104A outputs signals that are compliant to the LVDS standard. Its outputs can be DC-coupled to most common differential receivers. The following figure illustrates typical DC-coupled interface to common differential receivers

and assumes that the receivers have high impedance inputs. While most differential receivers have a common mode input range that can accommodate LVDS compliant signals, it is recommended to check respective receiver's data sheet prior to implementing the suggested interface implementation.

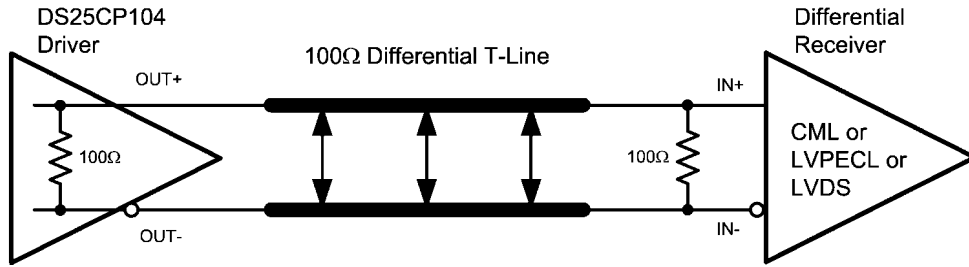

Typical DS25CP104A Output DC-Coupled Interface to an LVDS, CML or LVPECL Receiver 30073634

Typical Performance Characteristics

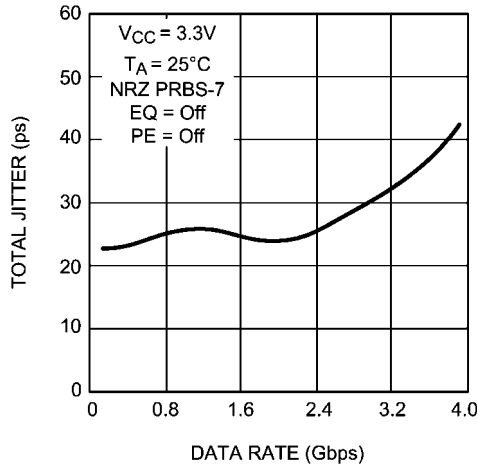

Total Jitter as a Function of Data Rate

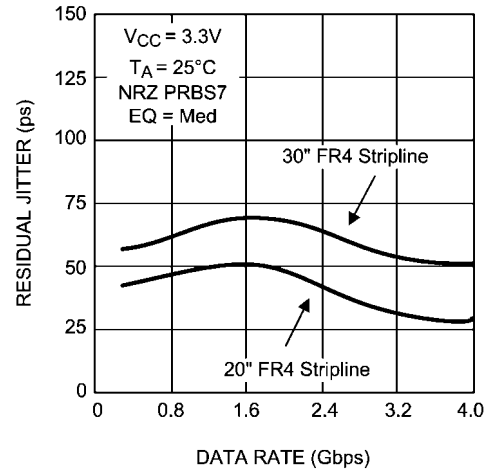

Residual Jitter as a Function of Data Rate, FR4 Stripline Length and EQ Level

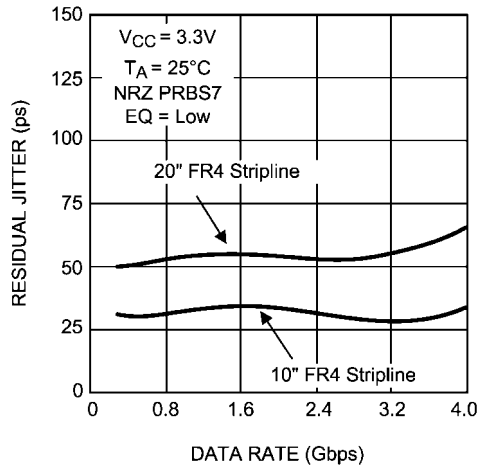

Residual Jitter as a Function of Data Rate, FR4 Stripline Length and EQ Level

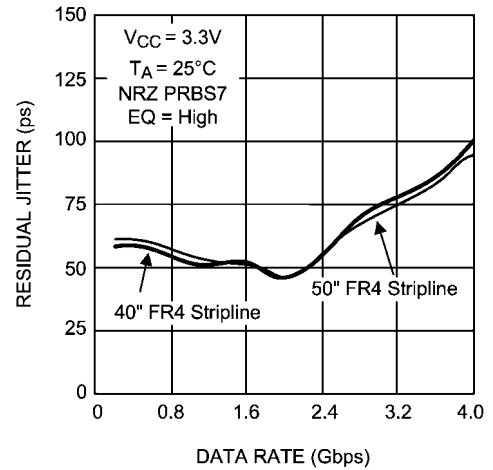

Residual Jitter as a Function of Data Rate, FR4 Stripline Length and EQ Level

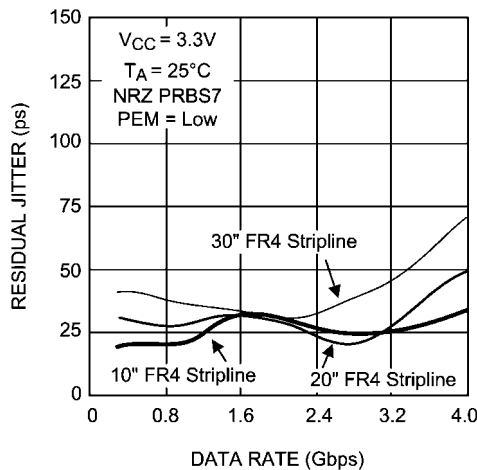

Residual Jitter as a Function of Data Rate, FR4 Stripline Length and PE Level

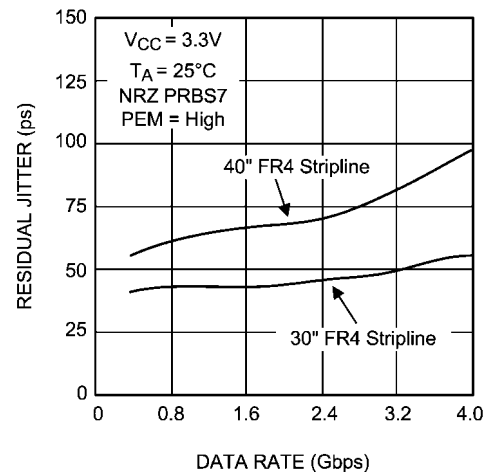

Residual Jitter as a Function of Data Rate, FR4 Stripline Length and PE Level

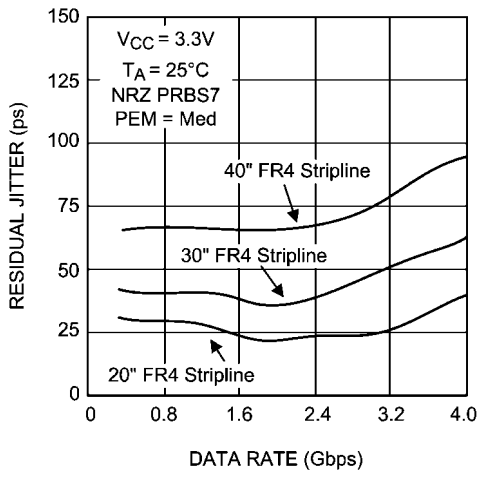

Residual Jitter as a Function of Data Rate, FR4 Stripline Length and PE Level

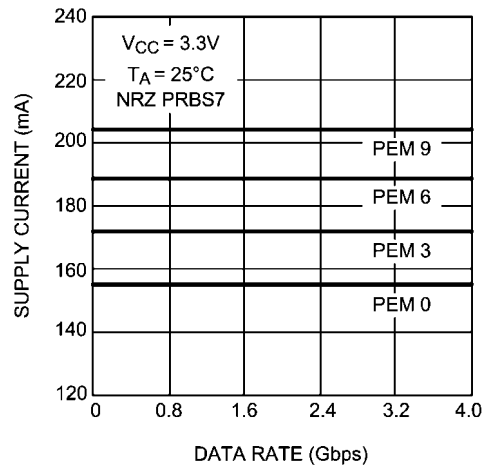

Supply Current as a Function of Data Rate and PE Level

Typical Performance

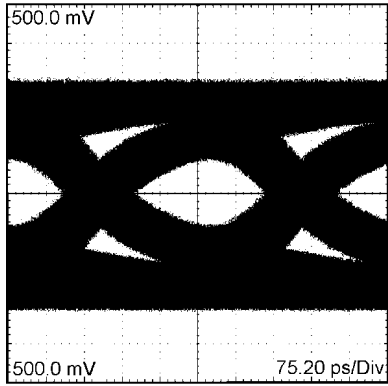

30073662
A 2.5 Gbps NRZ PRBS-23 without PE
After 30" Differential FR-4 Stripline
H: 75 ps / DIV, V: 100 mV / DIV

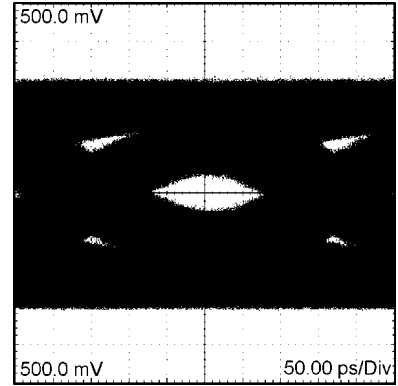

30073663
A 3.125 Gbps NRZ PRBS-23 without PE
After 30" Differential FR-4 Stripline
H: 50 ps / DIV, V: 100 mV / DIV

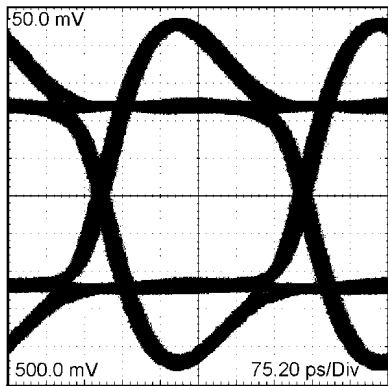

30073660
A 2.5 Gbps NRZ PRBS-23 with High PE
After 2" Differential FR-4 Microstrip
H: 75 ps / DIV, V: 100 mV / DIV

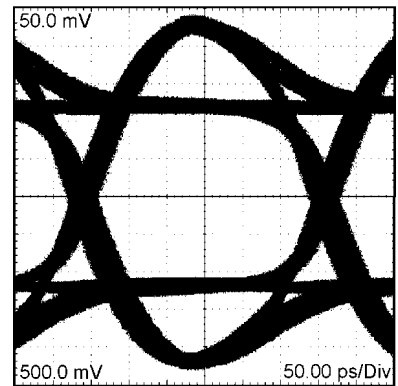

30073661
A 3.125 Gbps NRZ PRBS-23 with High PE
After 2" Differential FR-4 Microstrip
H: 50 ps / DIV, V: 100 mV / DIV

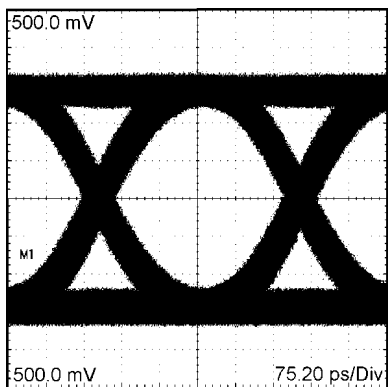

30073664
A 2.5 Gbps NRZ PRBS-23 with High PE
After 30" Differential FR-4 Stripline
H: 75 ps / DIV, V: 100 mV / DIV

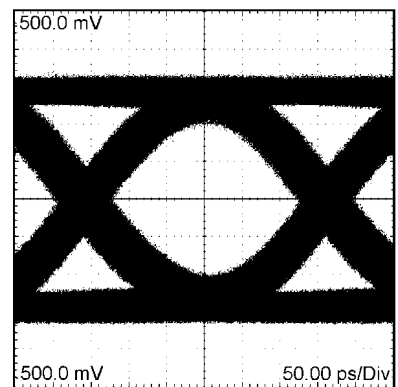

30073665
A 3.125 Gbps NRZ PRBS-23 with High PE
After 30" Differential FR-4 Stripline
H: 50 ps / DIV, V: 100 mV / DIV

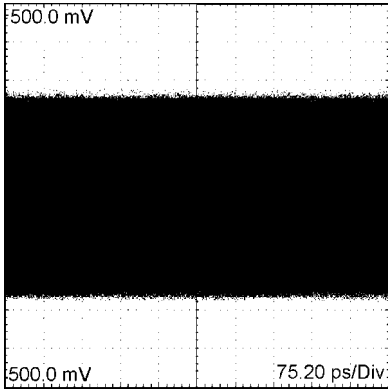

30073666
A 2.5 Gbps NRZ PRBS-23 without EQ
After 60" Differential FR-4 Stripline
H: 75 ps / DIV, V: 100 mV / DIV

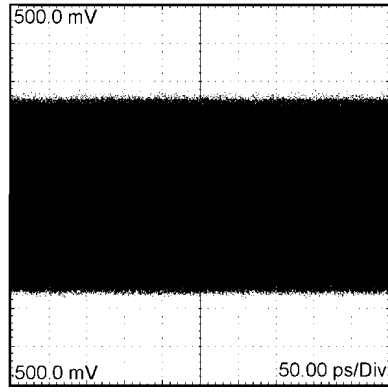

30073667
A 3.125 Gbps NRZ PRBS-23 without EQ
After 60" Differential FR-4 Stripline
H: 50 ps / DIV, V: 100 mV / DIV

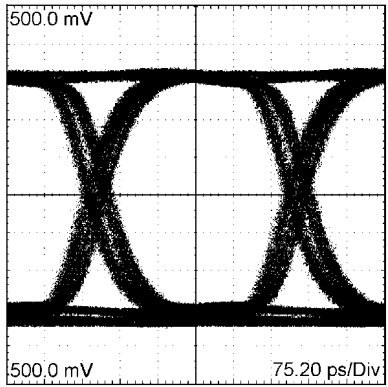

30073668
A 2.5 Gbps NRZ PRBS-23 with High EQ
After 60" Differential FR-4 Stripline
H: 75 ps / DIV, V: 100 mV / DIV

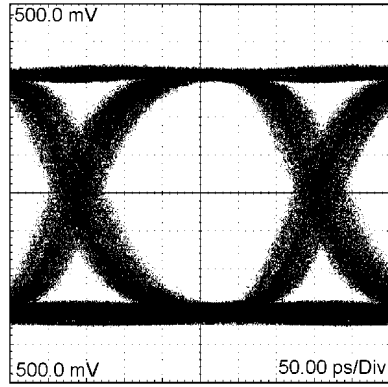

30073669
A 3.125 Gbps NRZ PRBS-23 with High EQ
After 60" Differential FR-4 Stripline
H: 50 ps / DIV, V: 100 mV / DIV

Physical Dimensions inches (millimeters) unless otherwise noted

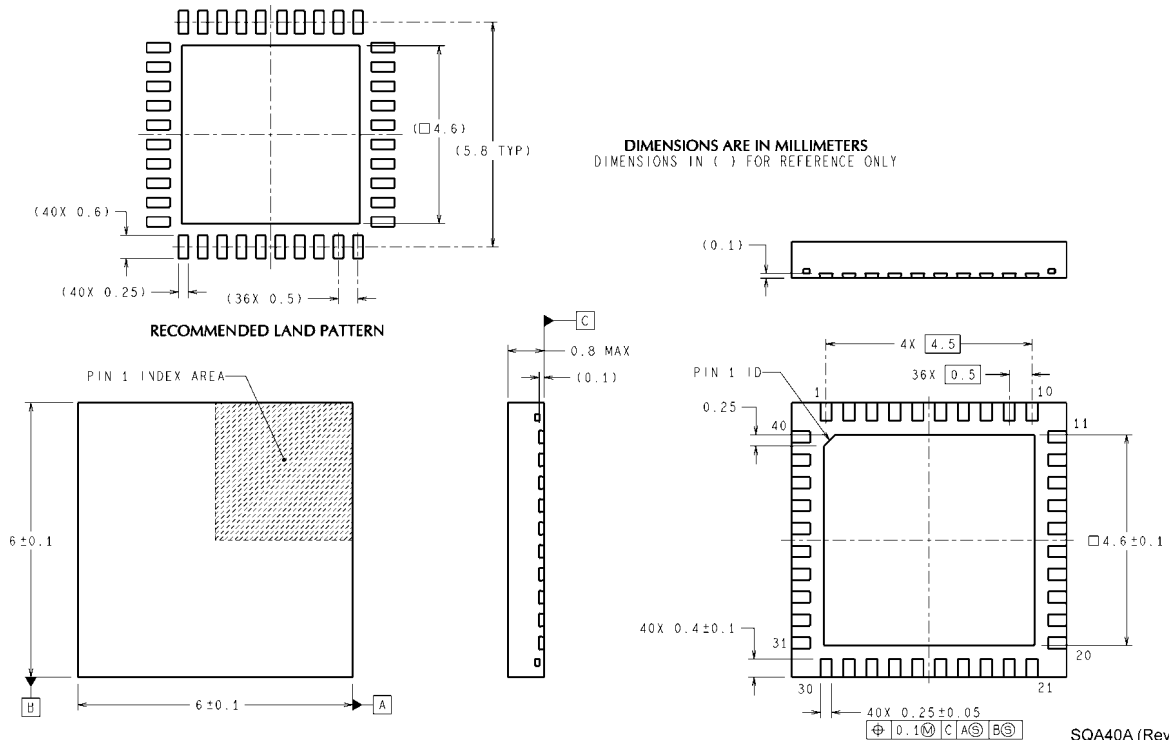

Order Number DS25CP104ATSQ
NS Package Number SQA40A
(See AN-1187 for PCB Design and Assembly Recommendations)

Notes

DS25CP104A

Notes

For more National Semiconductor product information and proven design tools, visit the following Web sites at:

Products		Design Support	
Amplifiers	www.national.com/amplifiers	WEBENCH	www.national.com/webench
Audio	www.national.com/audio	Analog University	www.national.com/AU
Clock Conditioners	www.national.com/timing	App Notes	www.national.com/appnotes
Data Converters	www.national.com/adc	Distributors	www.national.com/contacts
Displays	www.national.com/displays	Green Compliance	www.national.com/quality/green
Ethernet	www.national.com/ethernet	Packaging	www.national.com/packaging
Interface	www.national.com/interface	Quality and Reliability	www.national.com/quality
LVDS	www.national.com/lvds	Reference Designs	www.national.com/refdesigns
Power Management	www.national.com/power	Feedback	www.national.com/feedback
Switching Regulators	www.national.com/switchers		
LDOs	www.national.com/lido		
LED Lighting	www.national.com/led		
PowerWise	www.national.com/powerwise		
Serial Digital Interface (SDI)	www.national.com/sdi		
Temperature Sensors	www.national.com/tempsensors		
Wireless (PLL/VCO)	www.national.com/wireless		

THE CONTENTS OF THIS DOCUMENT ARE PROVIDED IN CONNECTION WITH NATIONAL SEMICONDUCTOR CORPORATION ("NATIONAL") PRODUCTS. NATIONAL MAKES NO REPRESENTATIONS OR WARRANTIES WITH RESPECT TO THE ACCURACY OR COMPLETENESS OF THE CONTENTS OF THIS PUBLICATION AND RESERVES THE RIGHT TO MAKE CHANGES TO SPECIFICATIONS AND PRODUCT DESCRIPTIONS AT ANY TIME WITHOUT NOTICE. NO LICENSE, WHETHER EXPRESS, IMPLIED, ARISING BY ESTOPPEL OR OTHERWISE, TO ANY INTELLECTUAL PROPERTY RIGHTS IS GRANTED BY THIS DOCUMENT.

TESTING AND OTHER QUALITY CONTROLS ARE USED TO THE EXTENT NATIONAL DEEMS NECESSARY TO SUPPORT NATIONAL'S PRODUCT WARRANTY. EXCEPT WHERE MANDATED BY GOVERNMENT REQUIREMENTS, TESTING OF ALL PARAMETERS OF EACH PRODUCT IS NOT NECESSARILY PERFORMED. NATIONAL ASSUMES NO LIABILITY FOR APPLICATIONS ASSISTANCE OR BUYER PRODUCT DESIGN. BUYERS ARE RESPONSIBLE FOR THEIR PRODUCTS AND APPLICATIONS USING NATIONAL COMPONENTS. PRIOR TO USING OR DISTRIBUTING ANY PRODUCTS THAT INCLUDE NATIONAL COMPONENTS, BUYERS SHOULD PROVIDE ADEQUATE DESIGN, TESTING AND OPERATING SAFEGUARDS.

EXCEPT AS PROVIDED IN NATIONAL'S TERMS AND CONDITIONS OF SALE FOR SUCH PRODUCTS, NATIONAL ASSUMES NO LIABILITY WHATSOEVER, AND NATIONAL DISCLAIMS ANY EXPRESS OR IMPLIED WARRANTY RELATING TO THE SALE AND/OR USE OF NATIONAL PRODUCTS INCLUDING LIABILITY OR WARRANTIES RELATING TO FITNESS FOR A PARTICULAR PURPOSE, MERCHANTABILITY, OR INFRINGEMENT OF ANY PATENT, COPYRIGHT OR OTHER INTELLECTUAL PROPERTY RIGHT.

LIFE SUPPORT POLICY

NATIONAL'S PRODUCTS ARE NOT AUTHORIZED FOR USE AS CRITICAL COMPONENTS IN LIFE SUPPORT DEVICES OR SYSTEMS WITHOUT THE EXPRESS PRIOR WRITTEN APPROVAL OF THE CHIEF EXECUTIVE OFFICER AND GENERAL COUNSEL OF NATIONAL SEMICONDUCTOR CORPORATION. As used herein:

Life support devices or systems are devices which (a) are intended for surgical implant into the body, or (b) support or sustain life and whose failure to perform when properly used in accordance with instructions for use provided in the labeling can be reasonably expected to result in a significant injury to the user. A critical component is any component in a life support device or system whose failure to perform can be reasonably expected to cause the failure of the life support device or system or to affect its safety or effectiveness.

National Semiconductor and the National Semiconductor logo are registered trademarks of National Semiconductor Corporation. All other brand or product names may be trademarks or registered trademarks of their respective holders.

Copyright© 2008 National Semiconductor Corporation

For the most current product information visit us at www.national.com



National Semiconductor Americas Technical Support Center
 Email: support@nsc.com
 Tel: 1-800-272-9959

National Semiconductor Europe Technical Support Center
 Email: europe.support@nsc.com
 German Tel: +49 (0) 180 5010 771
 English Tel: +44 (0) 870 850 4288

National Semiconductor Asia Pacific Technical Support Center
 Email: ap.support@nsc.com

National Semiconductor Japan Technical Support Center
 Email: jpn.feedback@nsc.com