

# AMIS-42671

## High Speed Autobaud CAN Transceiver

### General Description

The AMIS-42671 CAN transceiver with autobaud is the interface between a controller area network (CAN) protocol controller and the physical bus. It may be used in both 12 V and 24 V systems. The transceiver provides differential transmit capability to the bus and differential receive capability to the CAN controller. Due to the wide common-mode voltage range of the receiver inputs, the AMIS-42671 is able to reach outstanding levels of electromagnetic susceptibility (EMS). Similarly, extremely low electromagnetic emission (EME) is achieved by the excellent matching of the output signals.

The AMIS-42671 is primarily intended for industrial network applications where long network lengths are mandatory. Examples are elevators, in-building networks, process control and trains. To cope with the long bus delay the communication speed needs to be low. AMIS-42671 allows low transmit data rates down 10 kbit/s or lower. The autobaud function allows the CAN controller to determine the incoming baud rate without influencing the CAN communication on the bus.

### Features

- Fully compatible with the ISO 11898-2 standard
- Autobaud function
- Wide range of bus communication speed (0 up to 1 Mbit/s)
- Allows low transmit data rate in networks exceeding 1 km
- Ideally suited for 12 V and 24 V industrial and automotive applications
- Low electromagnetic emission (EME), common-mode choke is no longer required
- Differential receiver with wide common-mode range ( $\pm 35$  V) for high EMS
- No disturbance of the bus lines with an un-powered node
- Thermal protection
- Bus pins protected against transients
- Silent mode in which the transmitter is disabled
- Short circuit proof to supply voltage and ground
- Logic level inputs compatible with 3.3 V devices
- ESD protection for CAN bus at  $\pm 8$  kV
- These are Pb-Free Devices\*

\*For additional information on our Pb-Free strategy and soldering details, please download the ON Semiconductor Soldering and Mounting Techniques Reference Manual, SOLDERRM/D.



ON Semiconductor®

<http://onsemi.com>

### PIN ASSIGNMENT

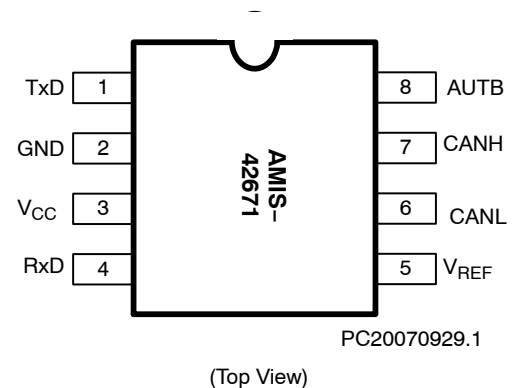

### ORDERING INFORMATION

See detailed ordering and shipping information in the package dimensions section on page 12 of this data sheet.

**Table 1. TECHNICAL CHARACTERISTICS**

Symbol	Parameter	Condition	Max	Max	Unit
V <sub>CANH</sub>	DC Voltage at Pin CANH	0 < V <sub>CC</sub> < 5.25V; no time limit	-45	+45	V
V <sub>CANL</sub>	DC Voltage at Pin CANL	0 < V <sub>CC</sub> < 5.25V; no time limit	-45	+45	V
V <sub>o(dif)(bus_dom)</sub>	Differential Bus Output Voltage in Dominant State	42.5Ω < R <sub>LT</sub> < 60Ω	1.5	3	V
t <sub>pd(rec-dom)</sub>	Propagation Delay TxD to RxD	See Figure 7	70	245	ns
t <sub>pd(dom-rec)</sub>	Propagation Delay TxD to RxD	See Figure 7	100	245	ns
C <sub>M-range</sub>	Input Common-Mode Range for Comparator	Guaranteed differential receiver threshold and leakage current	-35	+35	V
V <sub>CM-peak</sub>	Common-Mode Peak	See Figures 8 and 9 (Note 1)	-500	500	mV
V <sub>CM-step</sub>	Common-Mode Step	See Figures 8 and 9 (Note 1)	-150	150	mV

1. The parameters V<sub>CM-peak</sub> and V<sub>CM-step</sub> guarantee low electromagnetic emission.

# AMIS-42671

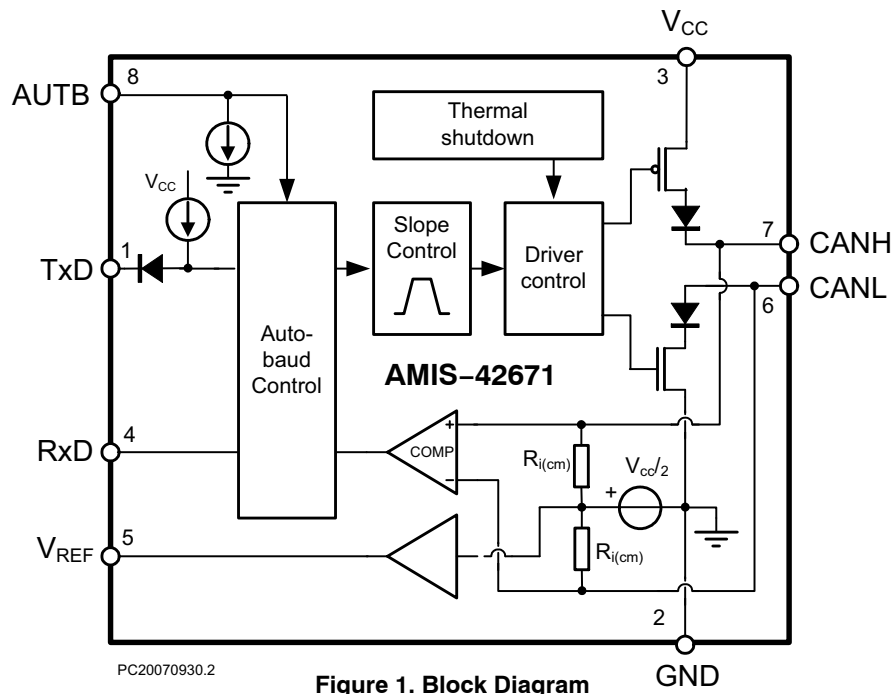

Figure 1. Block Diagram

Table 2. PIN DESCRIPTION

Pin	Name	Description
1	TxD	Transmit Data Input; Low Input → Dominant Driver; Internal Pullup Current
2	GND	Ground
3	V <sub>CC</sub>	Supply Voltage
4	RxD	Receive Data Output; Dominant Transmitter → Low Output
5	V <sub>REF</sub>	Reference Voltage Output
6	CANL	Low-Level CAN Bus Line (Low in Dominant Mode)
7	CANH	High-Level CAN Bus Line (High in Dominant Mode)
8	AUTB	Autobaud Mode Control Input; Internal Pulldown Current

**Table 3. ABSOLUTE MAXIMUM RATINGS**

Symbol	Parameter	Conditions	Min	Max	Unit
V <sub>CC</sub>	Supply Voltage		-0.3	+7	V
V <sub>CANH</sub>	DC Voltage at Pin CANH	0 < V <sub>CC</sub> < 5.25 V; No Time limit	-45	+45	V
V <sub>CANL</sub>	DC Voltage at Pin CANL	0 < V <sub>CC</sub> < 5.25 V; No Time Limit	-45	+45	V
V <sub>TxD</sub>	DC Voltage at Pin TxD		-0.3	V <sub>CC</sub> + 0.3	V
V <sub>RxD</sub>	DC Voltage at Pin RxD		-0.3	V <sub>CC</sub> + 0.3	V
V <sub>AUTB</sub>	DC Voltage at Pin AUTB		-0.3	V <sub>CC</sub> + 0.3	V
V <sub>REF</sub>	DC Voltage at Pin V <sub>REF</sub>		-0.3	V <sub>CC</sub> + 0.3	V
V <sub>tran(CANH)</sub>	Transient Voltage at Pin CANH	Note 2	-150	+150	V
V <sub>tran(CANL)</sub>	Transient Voltage at Pin CANL	Note 2	-150	+150	V
V <sub>esd</sub>	Electrostatic Discharge Voltage at All Pins	Note 3 Note 4	-4 -500	+4 +500	kV V
Latch-up	Static Latch-up at all Pins	Note 5		100	mA
T <sub>stg</sub>	Storage Temperature		-55	+155	°C
T <sub>A</sub>	Ambient Temperature		-40	+125	°C
T <sub>J</sub>	Maximum Junction Temperature		-40	+150	°C

Stresses exceeding Maximum Ratings may damage the device. Maximum Ratings are stress ratings only. Functional operation above the Recommended Operating Conditions is not implied. Extended exposure to stresses above the Recommended Operating Conditions may affect device reliability.

2. Applied transient waveforms in accordance with ISO 7637 part 3, test pulses 1, 2, 3a, and 3b (see Figure 3).
3. Standardized human body model ESD pulses in accordance to MIL883 method 3015.7.
4. Static latch-up immunity: static latch-up protection level when tested according to EIA/JESD78.
5. Standardized charged device model ESD pulses when tested according to EOS/ESD DS5.3-1993.

**Table 4. THERMAL CHARACTERISTICS**

Symbol	Parameter	Conditions	Value	Unit
R <sub>th(vj-a)</sub>	Thermal Resistance from Junction-to-Ambient in SO-8 package	In Free Air	150	k/W
R <sub>th(vj-s)</sub>	Thermal Resistance from Junction-to-Substrate of Bare Die	In Free Air	45	k/W

# AMIS-42671

## APPLICATION INFORMATION

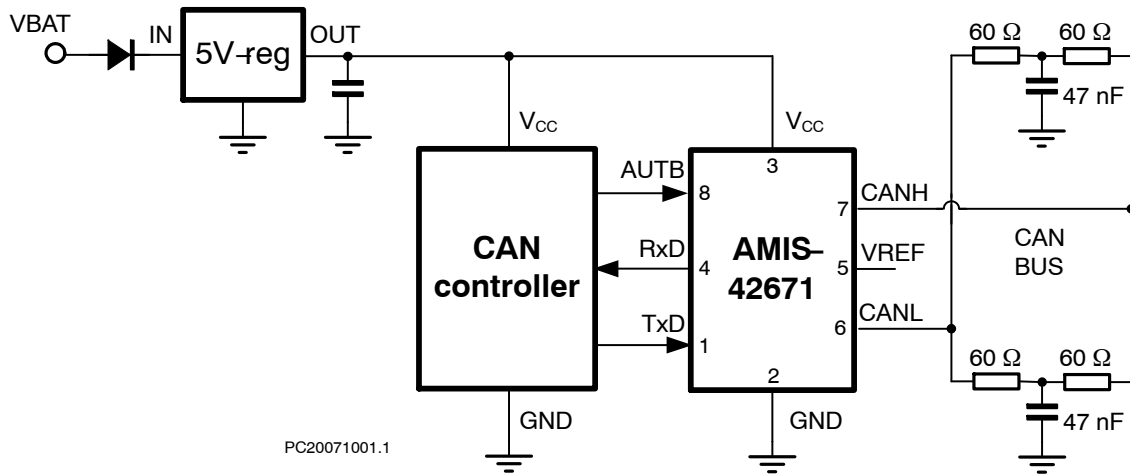

Figure 2. Application Diagram

FUNCTIONAL DESCRIPTION

Operating Modes

The behavior of AMIS-42671 under various conditions is illustrated in Table 5 below. In case the device is powered, one of two operating modes can be selected through Pin AUTB.

Table 5. FUNCTIONAL TABLE OF AMIS-42671 WHEN NOT CONNECTED TO THE BUS; x = don't care

VCC	Pin TxD	Pin AUTB	Pin CANH	Pin CANL	Bus State	Pin RxD
4.75 to 5.25 V	0	0 (or floating)	High	Low	Dominant	0
4.75 to 5.25 V	1 (or floating)	1	$V_{CC}/2$	$V_{CC}/2$	Recessive	1
4.75 to 5.25 V	1 (or floating)	x	$V_{CC}/2$	$V_{CC}/2$	Recessive	1
$V_{CC} < PORL$ (unpowered)	x	x	$0V < CANH < V_{CC}$	$0V < CANL < V_{CC}$	Recessive	1
$PORL < V_{CC} < 4.75V$	$>2V$	x	$0V < CANH < V_{CC}$	$0V < CANL < V_{CC}$	Recessive	1

High-Speed Mode

If pin AUTB is pulled low (or left floating), the transceiver is in its high-speed mode and is able to communicate via the bus lines. The signals are transmitted and received to the CAN controller via the pins TxD and RxD. The slopes on the bus line outputs are optimized to give extremely low electromagnetic emissions.

Autobaud Mode

If Pin AUTB is pulled high, AMIS-42671 is in Autobaud mode. The transmitter is disabled while the receiver remains active. All other IC functions also continue to operate. Normal bus activity can be monitored at the RxD pin and transmit data on TxD is looped back to RxD without influencing the CAN communication.

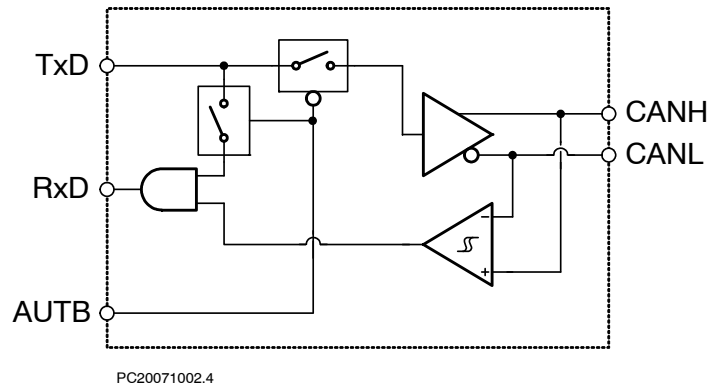

Figure 3. Simplified Schematic Diagram of Autobaud Function

In Autobaud mode the local CAN controller is able to detect the used communication speed of other transmitting network nodes. Bus communication is received and via the RxD pin sent to the CAN controller. If the CAN controller operates at the wrong baud rate, it will transmit an error frame. This message will be looped back to the CAN controller which will increment its error counter. The CAN controller will be reset with another baud rate. When an error-free message is received, the correct baud rate is detected. A logic low may now be applied to Pin AUTB, returning to the high-speed mode.

Overtemperature Detection

A thermal protection circuit protects the IC from damage by switching off the transmitter if the junction temperature exceeds a value of approximately 160°C. Because the transmitter dissipates most of the power, the power dissipation and temperature of the IC is reduced. All other IC functions continue to operate. The transmitter off-state resets when pin TxD goes high. The thermal protection circuit is particularly necessary when a bus line short-circuits.

### High Communication Speed Range

The transceiver is primarily intended for industrial applications. It allows very low baud rates needed for long bus length applications. But also high speed communication is possible up to 1 Mbit/s.

### Fail-safe Features

A current-limiting circuit protects the transmitter output stage from damage caused by an accidental short-circuit to

either positive or negative supply voltage, although power dissipation increases during this fault condition.

The Pins CANH and CANL are protected from automotive electrical transients (according to “ISO 7637”; see Figure 4). Pin TxD is pulled high internally should the input become disconnected.

ELECTRICAL CHARACTERISTICS

Definitions

All voltages are referenced to GND (Pin 2). Positive currents flow into the IC. Sinking current means the current is flowing into the pin; sourcing current means the current is flowing out of the pin.

**Table 6. DC CHARACTERISTICS**  $V_{CC} = 4.75\text{ V to }5.25\text{ V}$ ,  $T_A = -40^\circ\text{C to }+150^\circ\text{C}$ ;  $R_{LT} = 60\ \Omega$  unless specified otherwise.

Symbol	Parameter	Conditions	Min	Typ	Max	Unit
<b>SUPPLY (Pin <math>V_{CC}</math>)</b>						
$I_{CC}$	Supply current	Dominant; $V_{TXD} = 0\text{V}$ Recessive; $V_{TXD} = V_{CC}$	25 2	45 4	65 8	mA
<b>TRANSMITTER DATA INPUT (Pin <math>TxD</math>)</b>						
$V_{IH}$	High-Level Input Voltage	Output Recessive	2.0	–	$V_{CC} + 0.3$	V
$V_{IL}$	Low-Level Input Voltage	Output Dominant	–0.3	–	+0.8	V
$I_{IH}$	High-Level Input Current	$V_{TXD} = V_{CC}$	–1	0	+1	$\mu\text{A}$
$I_{IL}$	Low-Level Input Current	$V_{TXD} = 0\text{V}$	–75	–200	–350	$\mu\text{A}$
$C_i$	Input Capacitance	Not Tested	–	5	10	pF
<b>MODE SELECT (Pin <math>AUTB</math>)</b>						
$V_{IH}$	High-Level Input Voltage	Autobaud Mode	2.0	–	$V_{CC} + 0.3$	V
$V_{IL}$	Low-Level Input Voltage	High-Speed Mode	–0.3	–	+0.8	V
$I_{IH}$	High-Level Input Current	$V_S = 2\text{ V}$	20	30	50	$\mu\text{A}$
$I_{IL}$	Low-Level Input Current	$V_S = 0.8\text{ V}$	15	30	45	$\mu\text{A}$
<b>Receiver Data Output (Pin <math>RxD</math>)</b>						
$V_{OH}$	High-Level Output Voltage	$I_{RXD} = -10\text{ mA}$	$0.6 \times V_{CC}$	$0.75 \times V_{CC}$		V
$V_{OL}$	Low-Level Output Voltage	$I_{RXD} = 6\text{ mA}$		0.25	0.45	V
<b>REFERENCE VOLTAGE OUTPUT (Pin <math>V_{REF}</math>)</b>						
$V_{REF}$	Reference Output Voltage	$-50\ \mu\text{A} < I_{VREF} < +50\ \mu\text{A}$	$0.45 \times V_{CC}$	$0.50 \times V_{CC}$	$0.55 \times V_{CC}$	V
$V_{REF\_CM}$	Reference Output Voltage for Full Common Mode Range	$-35\text{ V} < V_{CANH} < +35\text{ V}$ ; $-35\text{ V} < V_{CANL} < +35\text{ V}$	$0.40 \times V_{CC}$	$0.50 \times V_{CC}$	$0.60 \times V_{CC}$	V
<b>BUS LINES (Pins <math>CANH</math> and <math>CANL</math>)</b>						
$V_{o(reces)}(CANH)$	Recessive Bus Voltage at Pin $CANH$	$V_{TXD} = V_{CC}$ ; no load	2.0	2.5	3.0	V
$V_{o(reces)}(CANL)$	Recessive Bus Voltage at Pin $CANL$	$V_{TXD} = V_{CC}$ ; no load	2.0	2.5	3.0	V
$I_{o(reces)}(CANH)$	Recessive Output Current at Pin $CANH$	$-35\text{ V} < V_{CANH} < +35\text{ V}$ ; $0\text{ V} < V_{CC} < 5.25\text{ V}$	–2.5	–	+2.5	mA
$I_{o(reces)}(CANL)$	Recessive Output Current at Pin $CANL$	$-35\text{ V} < V_{CANL} < +35\text{ V}$ ; $0\text{ V} < V_{CC} < 5.25\text{ V}$	–2.5	–	+2.5	mA
$V_{o(dom)}(CANH)$	Dominant Output Voltage at Pin $CANH$	$V_{TXD} = 0\text{ V}$	3.0	3.6	4.25	V
$V_{o(dom)}(CANL)$	Dominant Output Voltage at Pin $CANL$	$V_{TXD} = 0\text{ V}$	0.5	1.4	1.75	V
$V_{o(diff)}(bus)$	Differential Bus Output Voltage ( $V_{CANH} - V_{CANL}$ )	$V_{TXD} = 0\text{ V}$ ; Dominant; $42.5\ \Omega < R_{LT} < 60\ \Omega$	1.5	2.25	3.0	V
		$V_{TXD} = V_{CC}$ ; Recessive; No load	–120	0	+50	mV
$I_{o(sc)}(CANH)$	Short Circuit Output Current at Pin $CANH$	$V_{CANH} = 0\text{ V}$ ; $V_{TXD} = 0\text{ V}$	–45	–70	–95	mA
$I_{o(sc)}(CANL)$	Short Circuit Output Current at Pin $CANL$	$V_{CANL} = 36\text{ V}$ ; $V_{TXD} = 0\text{ V}$	45	70	120	mA



# AMIS-42671

**Table 6. DC CHARACTERISTICS**  $V_{CC} = 4.75\text{ V to }5.25\text{ V}$ ,  $T_A = -40^\circ\text{C to }+150^\circ\text{C}$ ;  $R_{LT} = 60\ \Omega$  unless specified otherwise.

Symbol	Parameter	Conditions	Min	Typ	Max	Unit
<b>BUS LINES (Pins CANH and CANL)</b>						
$V_{i(dif)(th)}$	Differential Receiver Threshold voltage	$-5\text{ V} < V_{CANL} < +10\text{ V}$ ; $-5\text{ V} < V_{CANH} < +10\text{ V}$ ; See	0.5	0.7	0.9	V
$V_{ihcm(dif)(th)}$	Differential Receiver Threshold Voltage for High Common-Mode	$-35\text{ V} < V_{CANL} < +35\text{ V}$ ; $-35\text{ V} < V_{CANH} < +35\text{ V}$ ; See	0.25	0.7	1.05	V
$V_{i(dif)(hys)}$	Differential Receiver Input Voltage Hysteresis	$-5\text{ V} < V_{CANL} < +10\text{ V}$ ; $-5\text{ V} < V_{CANH} < +10\text{ V}$ ; See	50	70	100	mV
$R_{i(cm)(CANH)}$	Common-Mode Input Resistance at Pin CANH		15	25	37	k $\Omega$
$R_{i(cm)(CANL)}$	Common-Mode Input Resistance at Pin CANL		15	25	37	k $\Omega$
$R_{i(cm)(m)}$	Matching Between Pin CANH and Pin CANL Common-Mode Input Resistance	$V_{CANH} = V_{CANL}$	-3	0	+3	%
$R_{i(dif)}$	Differential Input Resistance		25	50	75	k $\Omega$
$R_{i(cm)(m)}$	Matching Between Pin CANH and Pin CANL Common-Mode Input Resistance	$V_{CANH} = V_{CANL}$	-3	0	+3	%
$R_{i(dif)}$	Differential Input Resistance		25	50	75	k $\Omega$
$C_{i(CANH)}$	Input Capacitance at Pin CANH	$V_{TxD} = V_{CC}$ ; Not Tested		7.5	20	pF
$C_{i(CANL)}$	Input Capacitance at Pin CANL	$V_{TxD} = V_{CC}$ ; Not Tested		7.5	20	pF
$C_{i(dif)}$	Differential Input Capacitance	$V_{TxD} = V_{CC}$ ; Not Tested		3.75	10	pF
$I_{LI(CANH)}$	Input Leakage Current at Pin CANH	$V_{CC} = 0\text{ V}$ ; $V_{CANH} = 5\text{ V}$	10	170	250	$\mu\text{A}$
$I_{LI(CANL)}$	Input Leakage Current at Pin CANL	$V_{CC} = 0\text{ V}$ ; $V_{CANL} = 5\text{ V}$	10	170	250	$\mu\text{A}$
$V_{CM-peak}$	Common-Mode Peak During Transition from Dom $\rightarrow$ Rec or Rec $\rightarrow$ Dom	See Figures 8 and 9	-500		500	mV
$V_{CM-step}$	Difference in Common-Mode Between Dominant and Recessive State	See Figures 8 and 9	-150		150	mV
<b>POWER-ON-RESET (POR)</b>						
PORL	POR Level	CANH, CANL, $V_{ref}$ in Tri-State Below POR Level	2.2	3.5	4.7	V
<b>THERMAL SHUTDOWN</b>						
$T_{J(sd)}$	Shutdown Junction Temperature		150	160	180	$^\circ\text{C}$
<b>TIMING CHARACTERISTICS (see Figures 6 and 7)</b>						
$t_{d(TxD-BUSon)}$	Delay TxD to Bus Active	$V_s = 0\text{ V}$	40	85	130	ns
$t_{d(TxD-BUSoff)}$	Delay TxD to Bus Inactive	$V_s = 0\text{ V}$	30	60	105	ns
$t_{d(BUSon-RxD)}$	Delay Bus Active to RxD	$V_s = 0\text{ V}$	25	55	105	ns
$t_{d(BUSoff-RxD)}$	Delay Bus Inactive to RxD	$V_s = 0\text{ V}$	65	100	135	ns
$t_{pd(rec-dom)}$	Propagation Delay TxD to RxD from Recessive to Dominant	$V_s = 0\text{ V}$	70		245	ns
$t_{d(dom-rec)}$	Propagation Delay TxD to RxD from Dominant to Recessive	$V_s = 0\text{ V}$	100		245	ns

# AMIS-42671

## MEASUREMENT SETUPS AND DEFINITIONS

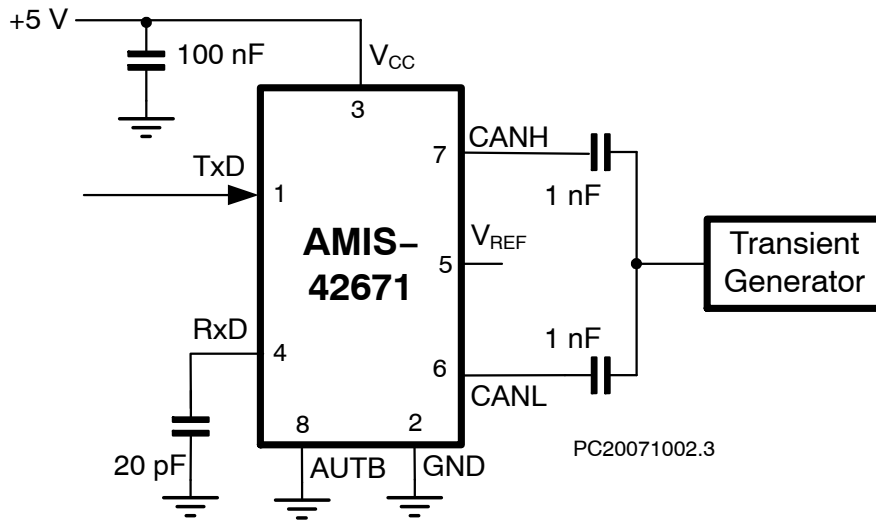

Figure 4. Test Circuit for Transients

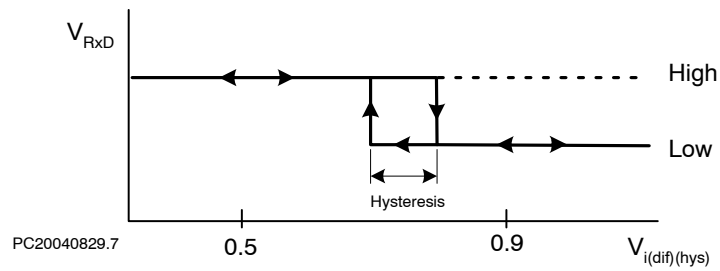

Figure 5. Hysteresis of the Receiver

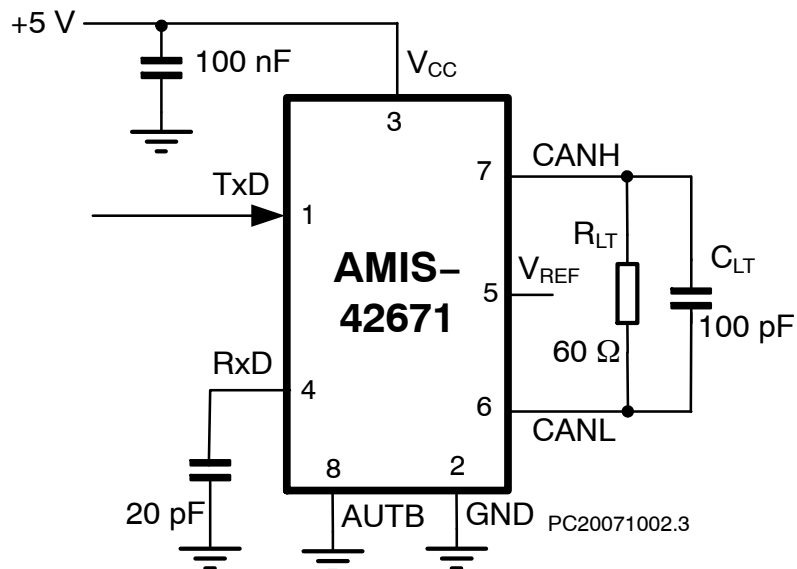

Figure 6. Test Circuit for Timing Characteristics

# AMIS-42671

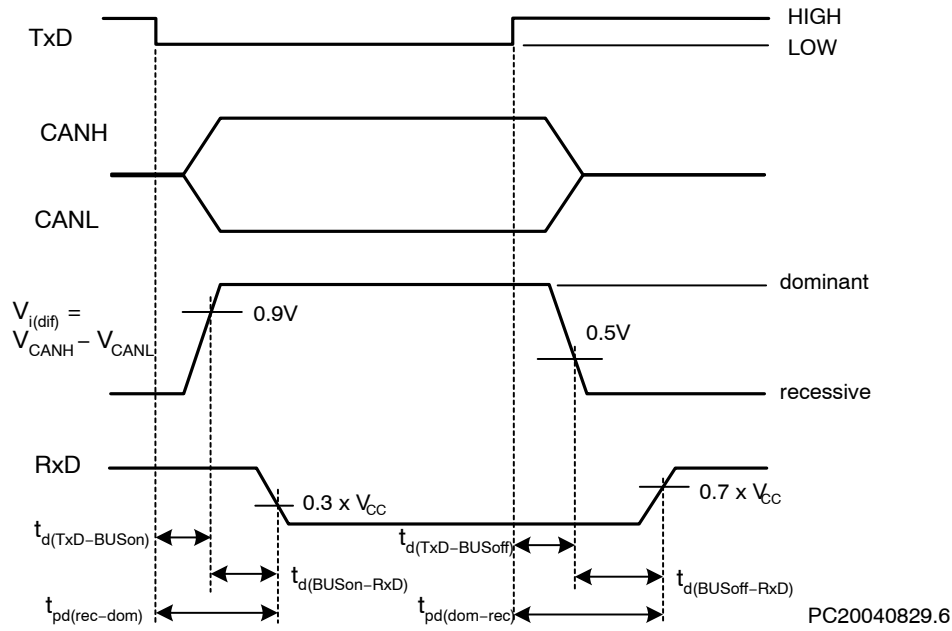

Figure 7. Timing Diagram for AC Characteristics

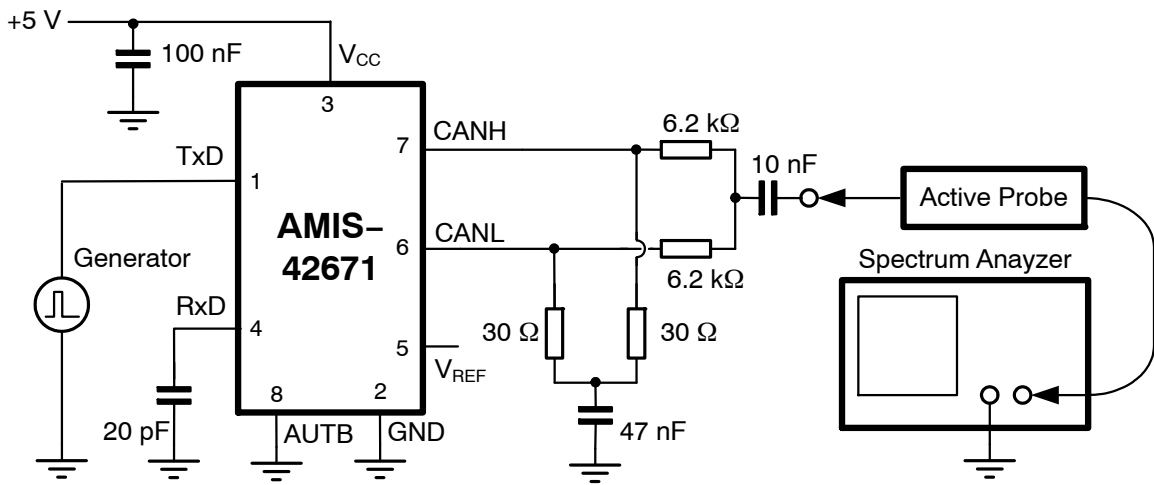

Figure 8. Basic Test Setup for Electromagnetic Measurement

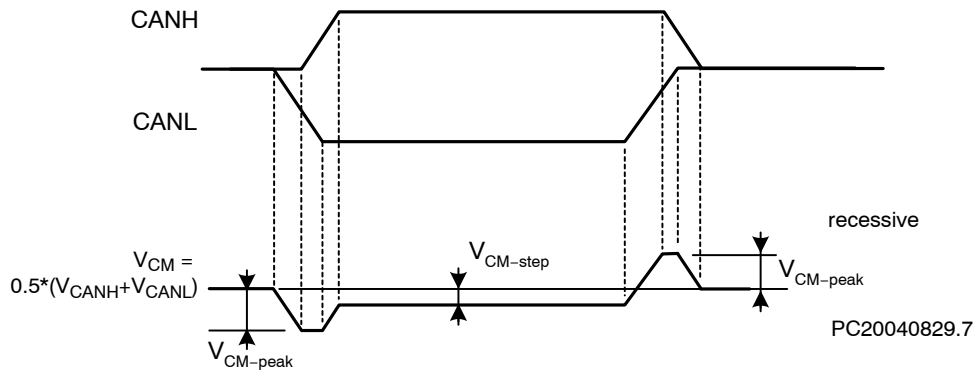

Figure 9. Common-Mode Voltage Peaks (see Measurement Setup Figure 8)

# AMIS-42671

## DEVICE ORDERING INFORMATION

Part Number	Temperature Range	Package Type	Shipping <sup>†</sup>
AMIS42671ICAB1G	-40°C - 125°C	SOIC-8 (Pb-Free)	96 Tube / Tray
AMIS42671ICAB1RG	-40°C - 125°C	SOIC-8 (Pb-Free)	3000 / Tape & Reel

<sup>†</sup>For information on tape and reel specifications, including part orientation and tape sizes, please refer to our Tape and Reel Packaging Specifications Brochure, BRD8011/D.

# AMIS-42671

## PACKAGE DIMENSIONS

SOIC 8  
CASE 751AZ-01  
ISSUE O

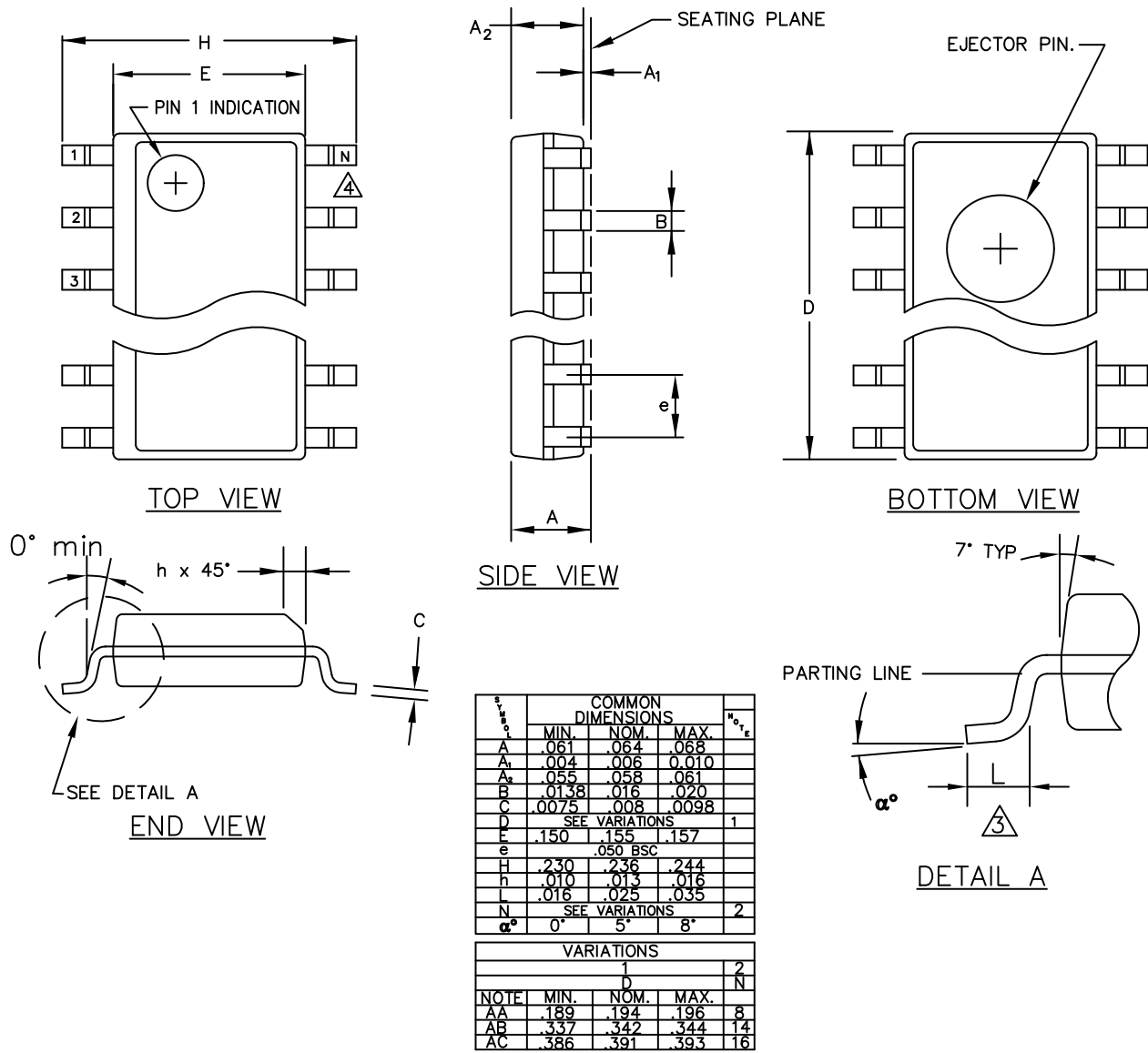

1. ALL DIMENSIONS ARE IN MILLIMETERS.

ON Semiconductor and are registered trademarks of Semiconductor Components Industries, LLC (SCILLC). SCILLC reserves the right to make changes without further notice to any products herein. SCILLC makes no warranty, representation or guarantee regarding the suitability of its products for any particular purpose, nor does SCILLC assume any liability arising out of the application or use of any product or circuit, and specifically disclaims any and all liability, including without limitation special, consequential or incidental damages. "Typical" parameters which may be provided in SCILLC data sheets and/or specifications can and do vary in different applications and actual performance may vary over time. All operating parameters, including "Typicals" must be validated for each customer application by customer's technical experts. SCILLC does not convey any license under its patent rights nor the rights of others. SCILLC products are not designed, intended, or authorized for use as components in systems intended for surgical implant into the body, or other applications intended to support or sustain life, or for any other application in which the failure of the SCILLC product could create a situation where personal injury or death may occur. Should Buyer purchase or use SCILLC products for any such unintended or unauthorized application, Buyer shall indemnify and hold SCILLC and its officers, employees, subsidiaries, affiliates, and distributors harmless against all claims, costs, damages, and expenses, and reasonable attorney fees arising out of, directly or indirectly, any claim of personal injury or death associated with such unintended or unauthorized use, even if such claim alleges that SCILLC was negligent regarding the design or manufacture of the part. SCILLC is an Equal Opportunity/Affirmative Action Employer. This literature is subject to all applicable copyright laws and is not for resale in any manner.

### PUBLICATION ORDERING INFORMATION

**LITERATURE FULFILLMENT:**  
Literature Distribution Center for ON Semiconductor  
P.O. Box 5163, Denver, Colorado 80217 USA  
**Phone:** 303-675-2175 or 800-344-3860 Toll Free USA/Canada  
**Fax:** 303-675-2176 or 800-344-3867 Toll Free USA/Canada  
**Email:** orderlit@onsemi.com

**N. American Technical Support:** 800-282-9855 Toll Free  
USA/Canada  
**Europe, Middle East and Africa Technical Support:**  
Phone: 421 33 790 2910  
**Japan Customer Focus Center**  
Phone: 81-3-5773-3850

**ON Semiconductor Website:** [www.onsemi.com](http://www.onsemi.com)  
**Order Literature:** <http://www.onsemi.com/orderlit>  
For additional information, please contact your local Sales Representative

AMIS-42671/D