

### GENERAL DESCRIPTION

The ICS8521 is a low skew, 1-to-9 Differential-to-HSTL Fanout Buffer. The ICS8521 has two selectable clock inputs. The CLK, nCLK pair can accept most standard differential input levels. The PCLK, nPCLK pair can accept LVPECL, CML, or SSTL input levels. The clock enable is internally synchronized to eliminate runt pulses on the outputs during asynchronous assertion/deassertion of the clock enable pin.

Guaranteed output skew, part-to-part skew and crossover voltage characteristics make the ICS8521 ideal for today's most advanced applications, such as IA64 and static RAMs.

### FEATURES

- 9 HSTL outputs
- Selectable differential CLK, nCLK or LVPECL clock inputs
- CLK, nCLK pair can accept the following differential input levels: LVPECL, LVDS, HSTL, SSTL, HCSL
- PCLK, nPCLK supports the following input types: LVPECL, CML, SSTL
- Maximum output frequency: 500MHz
- Output skew: 50ps (maximum)
- Part-to-part skew: 250ps (maximum)
- Propagation delay: 1.8ns (maximum)
- $V_{OH} = 1.4V$  (maximum)
- 3.3V core, 1.8V output operating supply voltages
- 0°C to 70°C ambient operating temperature
- Industrial temperature information available upon request

### BLOCK DIAGRAM

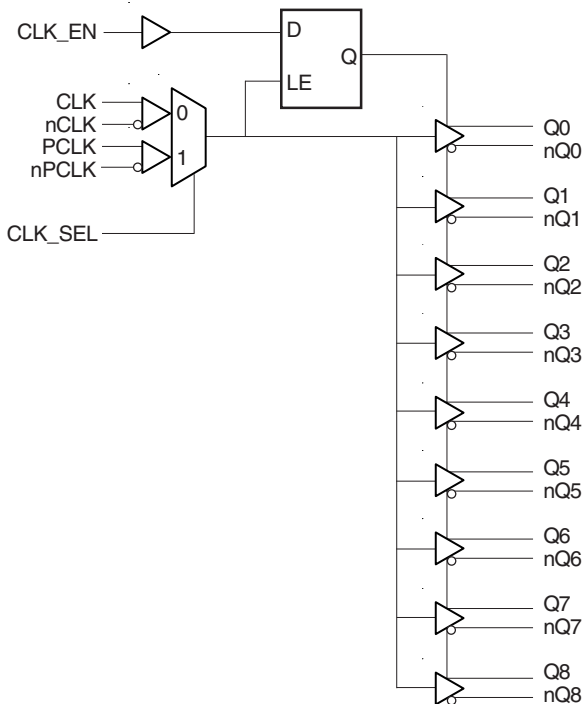

### PIN ASSIGNMENT

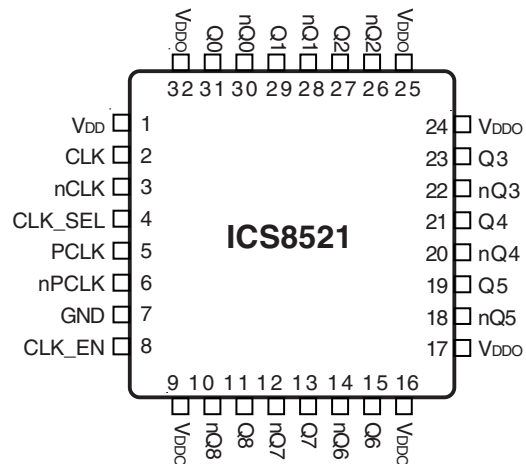

**32-Lead LQFP**  
7mm x 7mm x 1.4mm Package Body  
**Y Package**  
Top View



**TABLE 1. PIN DESCRIPTIONS**

Number	Name	Type		Description
1	V <sub>DD</sub>	Power		Core supply pin.
2	CLK	Input	Pulldown	Non-inverting differential clock input.
3	nCLK	Input	Pullup	Inverting differential clock input.
4	CLK_SEL	Input	Pulldown	Clock select input. When HIGH, selects PCLK, nPCLK inputs. When LOW, selects CLK, nCLK. LVTTTL / LVCMOS interface levels.
5	PCLK	Input	Pulldown	Non-inverting differential LVPECL clock input.
6	nPCLK	Input	Pullup	Inverting differential LVPECL clock input.
7	GND	Power		Power supply ground.
8	CLK_EN	Input	Pullup	Synchronizing clock enable. When HIGH, clock outputs follow clock input. When LOW, Q outputs are forced low, nQ outputs are forced high. LVCMOS /LVTTTL interface levels.
9, 16, 17, 24, 25, 32	V <sub>DDO</sub>	Power		Output supply pins.
10, 11	nQ8, Q8	Output		Differential output pair. HSTL interface level.
12, 13	nQ7, Q7	Output		Differential output pair. HSTL interface level.
14, 15	nQ6, Q6	Output		Differential output pair. HSTL interface level.
18, 19	nQ5, Q5	Output		Differential output pair. HSTL interface level.
20, 21	nQ4, Q4	Output		Differential output pair. HSTL interface level.
22, 23	nQ3, Q3	Output		Differential output pair. HSTL interface level.
26, 27	nQ2, Q2	Output		Differential output pair. HSTL interface level.
28, 29	nQ1, Q1	Output		Differential output pair. HSTL interface level.
30, 31	nQ0, Q0	Output		Differential output pair. HSTL interface level.

NOTE: *Pullup* and *Pulldown* refer to internal input resistors. See Table 2, Pin Characteristics, for typical values.

**TABLE 2. PIN CHARACTERISTICS**

Symbol	Parameter	Test Conditions	Minimum	Typical	Maximum	Units
C <sub>IN</sub>	Input Capacitance			4		pF
R <sub>PULLUP</sub>	Input Pullup Resistor			51		KΩ
R <sub>PULLDOWN</sub>	Input Pulldown Resistor			51		KΩ

**TABLE 3A. CONTROL INPUT FUNCTION TABLE**

Inputs			Outputs	
CLK_EN	CLK_SEL	Selected Sourced	Q0:Q8	nQ0:nQ8
0	0	CLK, nCLK	Disabled; LOW	Disabled; HIGH
0	1	PCLK, nPCLK	Disabled; LOW	Disabled; HIGH
1	0	CLK, nCLK	Enabled	Enabled
1	1	PCLK, nPCLK	Enabled	Enabled

After CLK\_EN switches, the clock outputs are disabled or enabled following a rising and falling input clock edge as shown in Figure 1.

In the active mode, the state of the outputs are a function of the CLK, nCLK and PCLK, nPCLK inputs as described in Table 3B.

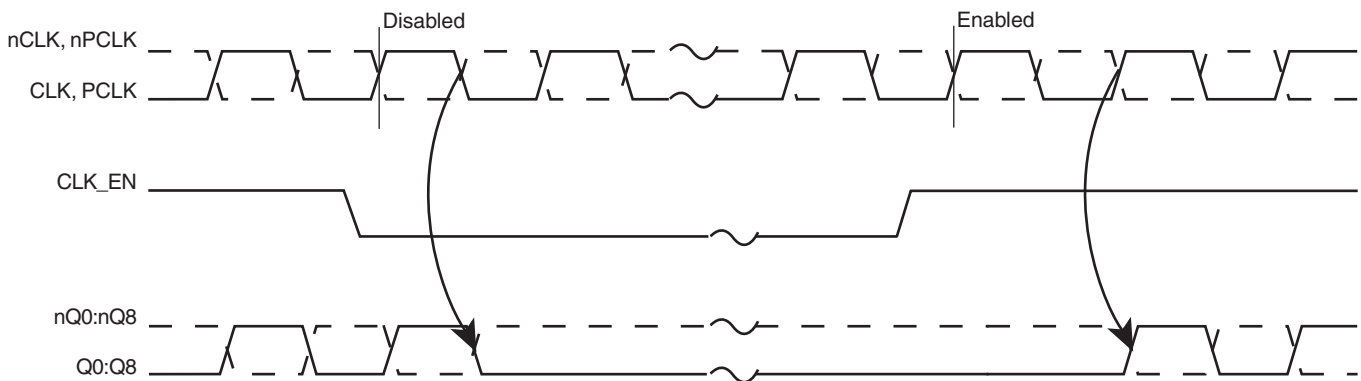

**FIGURE 1. CLK\_EN TIMING DIAGRAM**

**TABLE 3B. CLOCK INPUT FUNCTION TABLE**

Inputs		Outputs		Input to Output Mode	Polarity
CLK or PCLK	nCLK or nPCLK	Q0:Q8	nQ0:nQ8		
0	1	LOW	HIGH	Differential to Differential	Non Inverting
1	0	HIGH	LOW	Differential to Differential	Non Inverting
0	Biased; NOTE 1	LOW	HIGH	Single Ended to Differential	Non Inverting
1	Biased; NOTE 1	HIGH	LOW	Single Ended to Differential	Non Inverting
Biased; NOTE 1	0	HIGH	LOW	Single Ended to Differential	Inverting
Biased; NOTE 1	1	LOW	HIGH	Single Ended to Differential	Inverting

NOTE 1: Please refer to the Application Information "Wiring the Differential Input to Accept Single Ended Levels".



# ICS8521

## LOW SKEW, 1-TO-9 DIFFERENTIAL-TO-HSTL FANOUT BUFFER

### ABSOLUTE MAXIMUM RATINGS

Supply Voltage, $V_{DD}$	4.6V
Inputs, $V_i$	-0.5V to $V_{DD} + 0.5V$
Outputs, $I_o$	
Continuous Current	50mA
Surge Current	100mA
Package Thermal Impedance, $\theta_{JA}$	47.9°C/W (0 lfpm)
Storage Temperature, $T_{STG}$	-65°C to 150°C

NOTE: Stresses beyond those listed under Absolute Maximum Ratings may cause permanent damage to the device. These ratings are stress specifications only. Functional operation of product at these conditions or any conditions beyond those listed in the *DC Characteristics* or *AC Characteristics* is not implied. Exposure to absolute maximum rating conditions for extended periods may affect product reliability.

**TABLE 4A. POWER SUPPLY DC CHARACTERISTICS,  $V_{DD} = 3.3V \pm 5\%$ ,  $V_{DDO} = 1.8V \pm 0.2V$ ,  $T_A = 0^\circ C$  TO  $70^\circ C$**

Symbol	Parameter	Test Conditions	Minimum	Typical	Maximum	Units
$V_{DD}$	Core Supply Voltage		3.135	3.3	3.465	V
$V_{DDO}$	Output Supply Voltage		1.6	1.8	2.0	V
$I_{DD}$	Power Supply Current			60	80	mA

**TABLE 4B. LVCMOS/LVTTL DC CHARACTERISTICS,  $V_{DD} = 3.3V \pm 5\%$ ,  $V_{DDO} = 1.8V \pm 0.2V$ ,  $T_A = 0^\circ C$  TO  $70^\circ C$**

Symbol	Parameter	Test Conditions	Minimum	Typical	Maximum	Units
$V_{IH}$	CLK_EN, CLK_SEL		2		$V_{DD} + 0.3$	V
$V_{IL}$	CLK_EN, CLK_SEL		-0.3		0.8	V
$I_{IH}$	Input High Current	CLK_EN	$V_{IN} = V_{DD} = 3.465V$		5	$\mu A$
		CLK_SEL	$V_{IN} = V_{DD} = 3.465V$		150	$\mu A$
$I_{IL}$	Input Low Current	CLK_EN	$V_{IN} = 0V, V_{DD} = 3.465V$	-150		$\mu A$
		CLK_SEL	$V_{IN} = 0V, V_{DD} = 3.465V$	-5		$\mu A$

**TABLE 4C. DIFFERENTIAL DC CHARACTERISTICS,  $V_{DD} = 3.3V \pm 5\%$ ,  $V_{DDO} = 1.8V \pm 0.2V$ ,  $T_A = 0^\circ C$  TO  $70^\circ C$**

Symbol	Parameter	Test Conditions	Minimum	Typical	Maximum	Units
$I_{IH}$	Input High Current	CLK	$V_{IN} = V_{DD} = 3.465V$		150	$\mu A$
		nCLK	$V_{IN} = V_{DD} = 3.465V$		5	$\mu A$
$I_{IL}$	Input Low Current	CLK	$V_{IN} = 0V, V_{DD} = 3.465V$	-5		$\mu A$
		nCLK	$V_{IN} = 0V, V_{DD} = 3.465V$	-150		$\mu A$
$V_{PP}$	Peak-to-Peak Input Voltage		0.15		1.3	V
$V_{CMR}$	Common Mode Input Voltage; NOTE 1, 2		0.5		$V_{DD} - 0.85$	V

NOTE 1: For single ended applications, the maximum input voltage for CLK and nCLK is  $V_{DD} + 0.3V$ .

NOTE 2: Common mode voltage is defined as  $V_{IH}$ .



**TABLE 4D. LVPECL DC CHARACTERISTICS,  $V_{DD} = 3.3V \pm 5\%$ ,  $V_{DDO} = 1.8V \pm 0.2V$ ,  $T_A = 0^\circ C$  TO  $70^\circ C$**

Symbol	Parameter	Test Conditions	Minimum	Typical	Maximum	Units
$I_{IH}$	Input High Current	PCLK	$V_{DD} = V_{IN} = 3.465V$		150	$\mu A$
		nPCLK	$V_{DD} = V_{IN} = 3.465V$		5	$\mu A$
$I_{IL}$	Input Low Current	PCLK	$V_{DD} = 3.465V, V_{IN} = 0V$	-5		$\mu A$
		nPCLK	$V_{DD} = 3.465V, V_{IN} = 0V$	-150		$\mu A$
$V_{PP}$	Peak-to-Peak Input Voltage		0.3		1	V
$V_{CMR}$	Common Mode Input Voltage; NOTE 1, 2		1.5		$V_{DD}$	V

NOTE 1: Common mode voltage is defined as  $V_{IH}$ .

NOTE 2: For single ended applications, the maximum input voltage for PCLK and nPCLK is  $V_{DD} + 0.3V$ .

**TABLE 4E. HSTL DC CHARACTERISTICS,  $V_{DD} = 3.3V \pm 5\%$ ,  $V_{DDO} = 1.8V \pm 0.2V$ ,  $T_A = 0^\circ C$  TO  $70^\circ C$**

Symbol	Parameter	Test Conditions	Minimum	Typical	Maximum	Units
$V_{OH}$	Output High Voltage; NOTE 1		1.0		1.4	V
$V_{OL}$	Output Low Voltage; NOTE 1		0		0.4	V
$V_{OX}$	Output Crossover Voltage		$40\% \times (V_{OH} - V_{OL}) + V_{OL}$		$60\% \times (V_{OH} - V_{OL}) + V_{OL}$	V
$V_{SWING}$	Peak-to-Peak Output Voltage Swing		0.6		1.1	V

NOTE 1: Outputs terminated with  $50\Omega$  to ground.

**TABLE 5. AC CHARACTERISTICS,  $V_{DD} = 3.3V \pm 5\%$ ,  $V_{DDO} = 1.8V \pm 0.2V$ ,  $T_A = 0^\circ C$  TO  $70^\circ C$**

Symbol	Parameter	Test Conditions	Minimum	Typical	Maximum	Units
$f_{MAX}$	Output Frequency				500	MHz
$t_{PD}$	Propagation Delay; NOTE 1	$f \leq 250MHz$	1		1.8	ns
$t_{sk(o)}$	Output Skew; NOTE 2, 4				50	ps
$t_{sk(pp)}$	Part-to-Part Skew; NOTE 3, 4				250	ps
$t_R$	Output Rise Time	20% to 80% @ 50MHz	300		700	ps
$t_F$	Output Fall Time	20% to 80% @ 50MHz	300		700	ps
odc	Output Duty Cycle		48		52	%

All parameters measured at 250MHz unless noted otherwise.

NOTE 1: Measured from the differential input crossing point to the differential output crossing point.

Measured from  $V_{DD}/2$  to the output differential crossing point for single ended input levels.

NOTE 2: Defined as skew between outputs at the same supply voltage and with equal load conditions.

Measured at the output differential cross points.

NOTE 3: Defined as skew between outputs on different devices operating at the same supply voltages and with equal load conditions. Using the same type of inputs on each device, the outputs are measured at the differential cross points.

NOTE 4: This parameter is defined in accordance with JEDEC Standard 65.

## PARAMETER MEASUREMENT INFORMATION

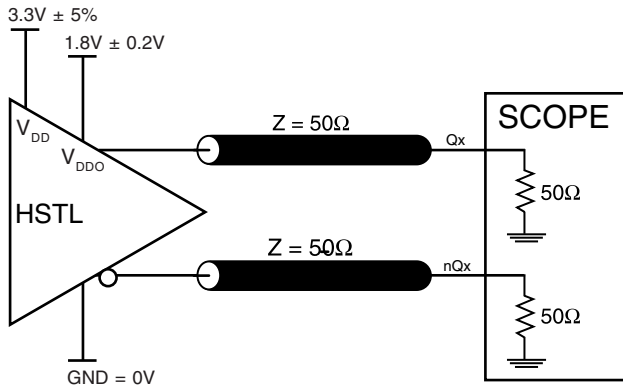

**3.3V CORE/1.8V OUTPUT LOAD AC TEST CIRCUIT**

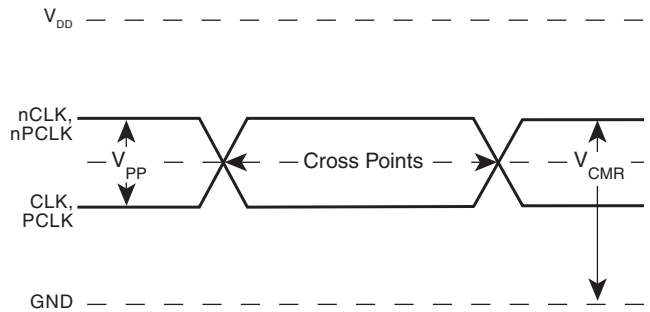

**DIFFERENTIAL INPUT LEVEL**

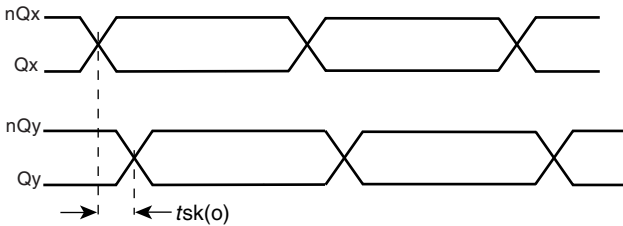

**OUTPUT SKEW**

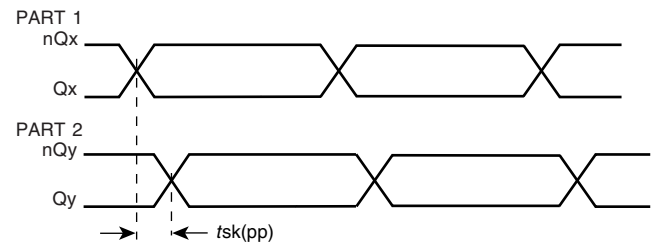

**PART-TO-PART SKEW**

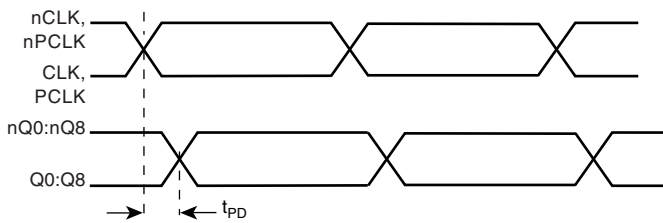

**PROPAGATION DELAY**

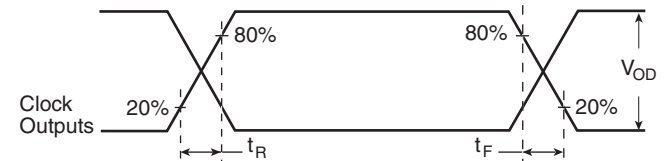

**OUTPUT RISE/FALL TIME**

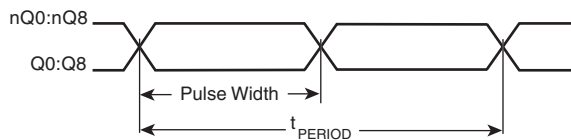

$$odc = \frac{t_{PW}}{t_{PERIOD}}$$

**odc & t<sub>PERIOD</sub>**

## APPLICATION INFORMATION

### WIRING THE DIFFERENTIAL INPUT TO ACCEPT SINGLE ENDED LEVELS

Figure 2 shows how the differential input can be wired to accept single ended levels. The reference voltage  $V_{REF} = V_{DD}/2$  is generated by the bias resistors R1, R2 and C1. This bias circuit should be located as close as possible to the input pin. The ratio

of R1 and R2 might need to be adjusted to position the  $V_{REF}$  in the center of the input voltage swing. For example, if the input clock swing is only 2.5V and  $V_{DD} = 3.3V$ ,  $V_{REF}$  should be 1.25V and  $R2/R1 = 0.609$ .

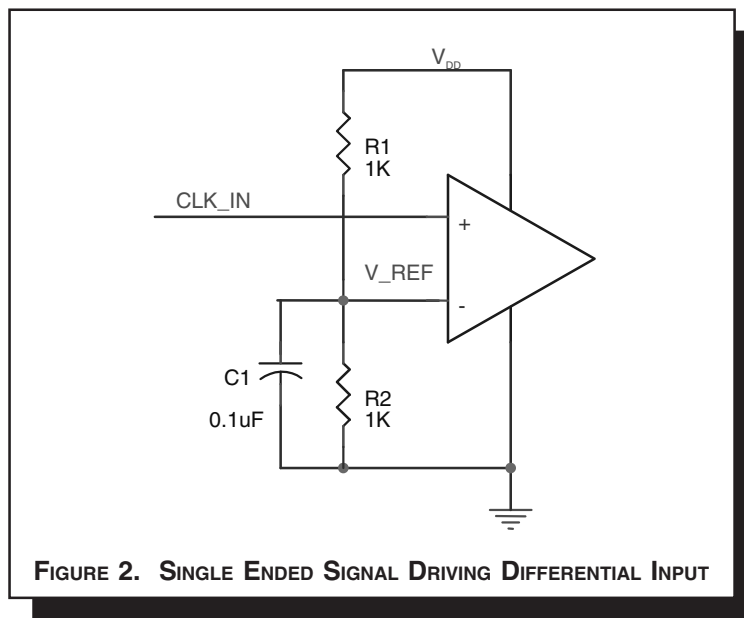

### DIFFERENTIAL CLOCK INPUT INTERFACE

The CLK /nCLK accepts LVDS, LVPECL, HSTL, SSTL, HCSTL and other differential signals. Both  $V_{SWING}$  and  $V_{OH}$  must meet the  $V_{PP}$  and  $V_{CMR}$  input requirements. Figures 3A to 3E show interface examples for the CLK/nCLK input driven by the most common driver types. The input interfaces suggested here

are examples only. Please consult with the vendor of the driver component to confirm the driver termination requirements. For example in *Figure 3A*, the input termination applies for HSTL drivers. If you are using an HSTL driver from another vendor, use their termination recommendation.

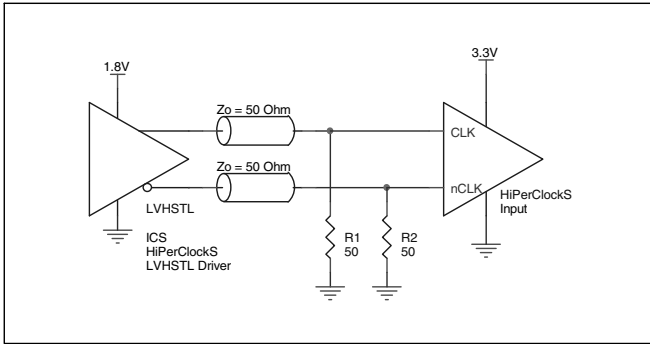

**FIGURE 3A. CLK/nCLK INPUT DRIVEN BY HSTL DRIVER**

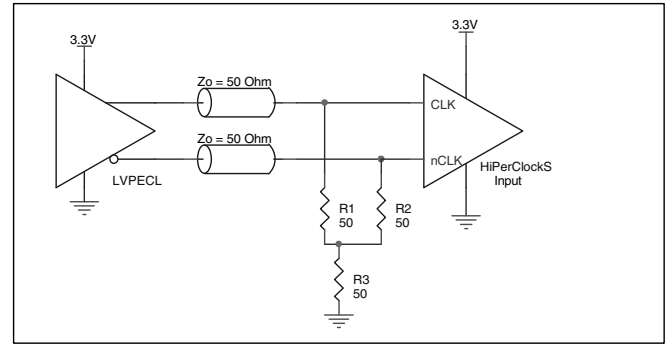

**FIGURE 3B. CLK/nCLK INPUT DRIVEN BY 3.3V LVPECL DRIVER**

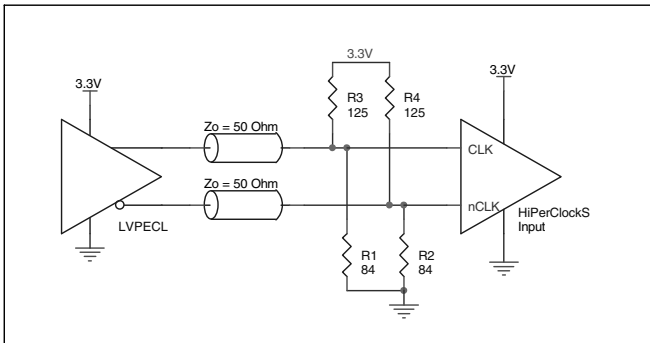

**FIGURE 3C. CLK/nCLK INPUT DRIVEN BY 3.3V LVPECL DRIVER**

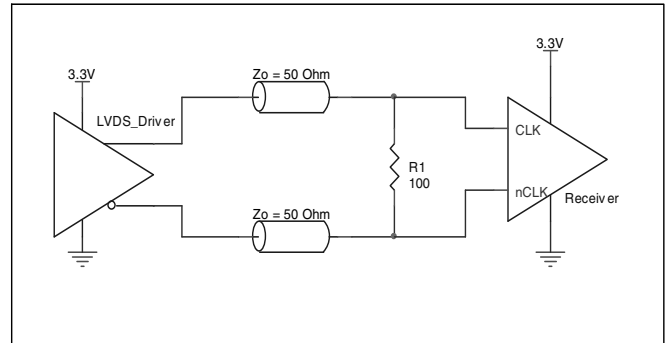

**FIGURE 3D. CLK/nCLK INPUT DRIVEN BY 3.3V LVDS DRIVER**

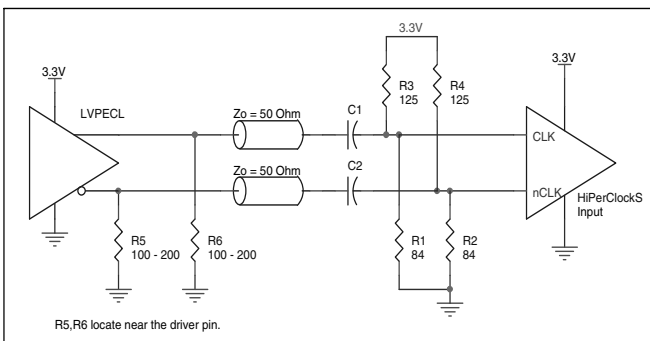

**FIGURE 3E. CLK/nCLK INPUT DRIVEN BY 3.3V LVPECL DRIVER WITH AC COUPLE**



### LVPECL CLOCK INPUT INTERFACE

The PCLK /nPCLK accepts LVPECL, CML, SSTL and other differential signals. Both  $V_{SWING}$  and  $V_{OH}$  must meet the  $V_{PP}$  and  $V_{CMR}$  input requirements. Figures 4A to 4F show interface examples for the PCLK/nPCLK input driven by the most common driver types. The input interfaces suggested here

are examples only. If the driver is from another vendor, use their termination recommendation. Please consult with the vendor of the driver component to confirm the driver termination requirements.

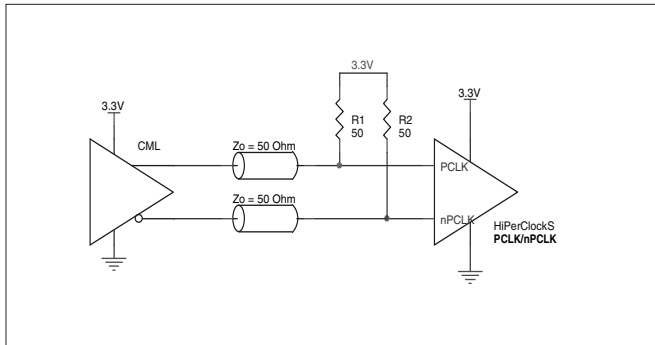

**FIGURE 4A. PCLK/nPCLK INPUT DRIVEN BY AN OPEN COLLECTOR CML DRIVER**

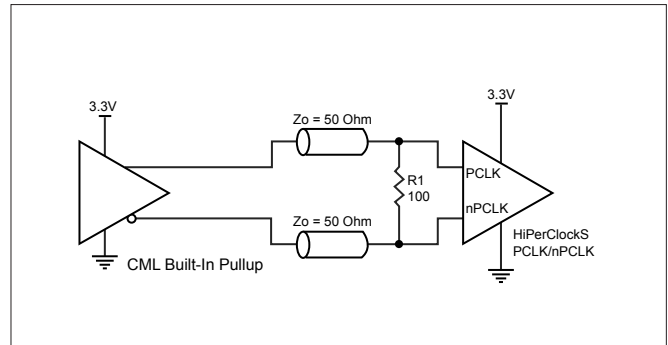

**FIGURE 4B. PCLK/nPCLK INPUT DRIVEN BY A BUILT-IN PULLUP CML DRIVER**

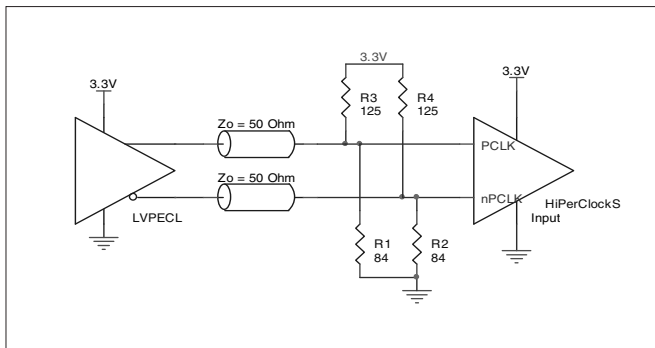

**FIGURE 4C. PCLK/nPCLK INPUT DRIVEN BY A 3.3V LVPECL DRIVER**

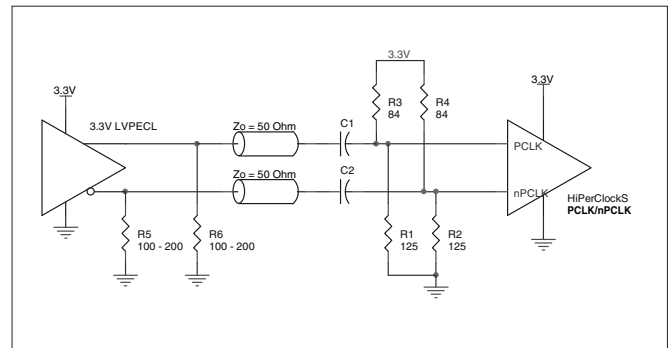

**FIGURE 4D. PCLK/nPCLK INPUT DRIVEN BY A 3.3V LVPECL DRIVER WITH AC COUPLE**

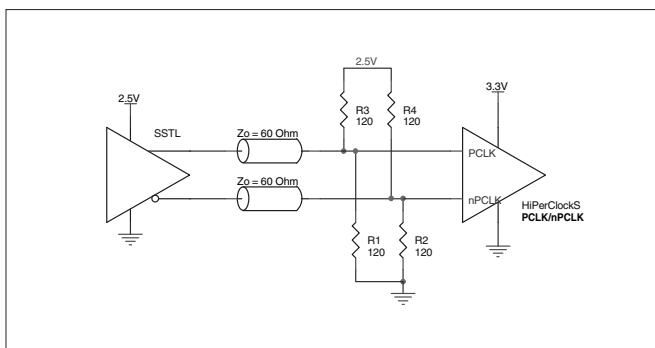

**FIGURE 4E. PCLK/nPCLK INPUT DRIVEN BY AN SSTL DRIVER**

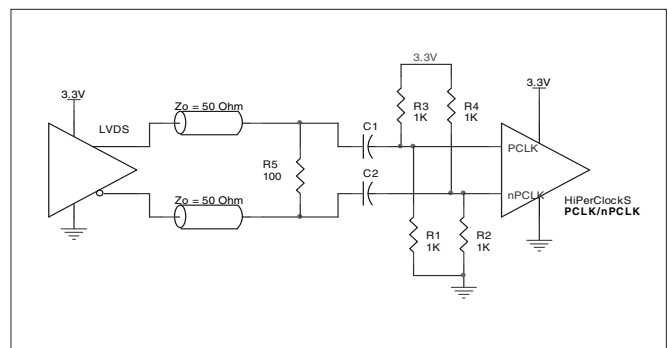

**FIGURE 4F. PCLK/nPCLK INPUT DRIVEN BY A 3.3V LVDS DRIVER**

## POWER CONSIDERATIONS

This section provides information on power dissipation and junction temperature for the ICS8521. Equations and example calculations are also provided.

### 1. Power Dissipation.

The total power dissipation for the ICS8521 is the sum of the core power plus the power dissipated in the load(s). The following is the power dissipation for  $V_{DD} = 3.3V + 5\% = 3.465V$ , which gives worst case results.

**NOTE:** Please refer to Section 3 for details on calculating power dissipated in the load.

- Power (core)<sub>MAX</sub> =  $V_{DD\_MAX} * I_{DD\_MAX} = 3.465V * 80mA = 277.2mW$
- Power (outputs)<sub>MAX</sub> = **32.8mW/Loaded Output pair**  
 If all outputs are loaded, the total power is  $9 * 32.8mW = 295.2mW$

**Total Power**<sub>MAX</sub> (3.465V, with all outputs switching) =  $277.2mW + 295.2mW = 572.4mW$

### 2. Junction Temperature.

Junction temperature,  $T_j$ , is the temperature at the junction of the bond wire and bond pad and directly affects the reliability of the device. The maximum recommended junction temperature for the devices is 125°C.

The equation for  $T_j$  is as follows:  $T_j = \theta_{JA} * Pd\_total + T_A$

$T_j$  = Junction Temperature

$\theta_{JA}$  = junction-to-ambient thermal resistance

$Pd\_total$  = Total device power dissipation (example calculation is in section 1 above)

$T_A$  = Ambient Temperature

In order to calculate junction temperature, the appropriate junction-to-ambient thermal resistance  $\theta_{JA}$  must be used. Assuming a moderate air flow of 200 linear feet per minute and a multi-layer board, the appropriate value is 42.1°C/W per Table 6 below. Therefore,  $T_j$  for an ambient temperature of 70°C with all outputs switching is:

$70^\circ C + 0.572W * 42.1^\circ C/W = 94.1^\circ C$ . This is well below the limit of 125°C.

This calculation is only an example.  $T_j$  will obviously vary depending on the number of loaded outputs, supply voltage, air flow, and the type of board (single layer or multi-layer).

**Table 6. Thermal Resistance  $\theta_{JA}$  for 32-pin LQFP, Forced Convection**

<b><math>\theta_{JA}</math> by Velocity (Linear Feet per Minute)</b>			
	<b>0</b>	<b>200</b>	<b>500</b>
Single-Layer PCB, JEDEC Standard Test Boards	67.8°C/W	55.9°C/W	50.1°C/W
Multi-Layer PCB, JEDEC Standard Test Boards	47.9°C/W	42.1°C/W	39.4°C/W

**NOTE:** Most modern PCB designs use multi-layered boards. The data in the second row pertains to most designs.

### 3. Calculations and Equations.

The purpose of this section is to derive the power dissipated into the load.

HSTL output driver circuit and termination are shown in *Figure 5*.

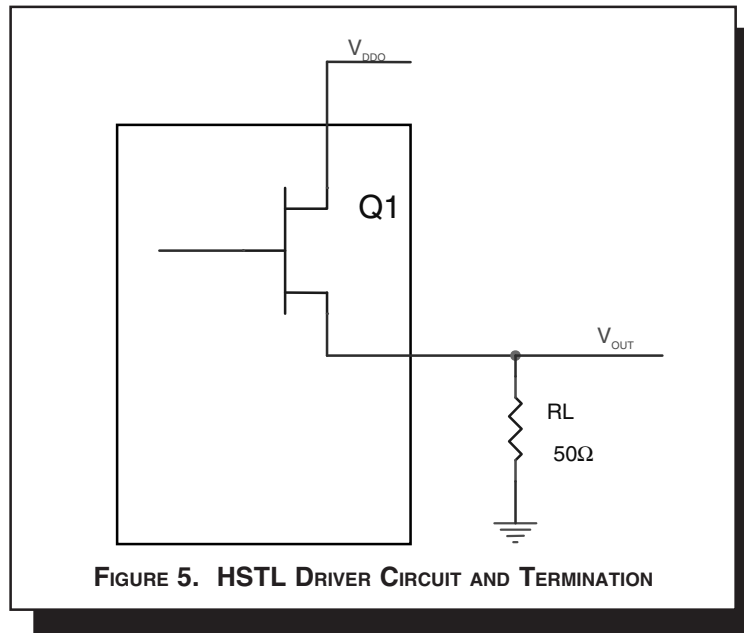

To calculate worst case power dissipation into the load, use the following equations which assume a 50Ω load.

Pd\_H is power dissipation when the output drives high.

Pd\_L is the power dissipation when the output drives low.

$$Pd_H = (V_{OH\_MAX} / R_L) * (V_{DDO\_MAX} - V_{OH\_MAX})$$

$$Pd_L = (V_{OL\_MAX} / R_L) * (V_{DDO\_MAX} - V_{OL\_MAX})$$

$$Pd_H = (1.0V/50\Omega) * (2V - 1.0V) = \mathbf{20mW}$$

$$Pd_L = (0.4V/50\Omega) * (2V - 0.4V) = \mathbf{12.8mW}$$

Total Power Dissipation per output pair = Pd\_H + Pd\_L = **32.8mW**

## RELIABILITY INFORMATION

TABLE 6.  $\theta_{JA}$  VS. AIR FLOW TABLE FOR 32 LEAD LQFP

$\theta_{JA}$ by Velocity (Linear Feet per Minute)			
	0	200	500
Single-Layer PCB, JEDEC Standard Test Boards	67.8°C/W	55.9°C/W	50.1°C/W
Multi-Layer PCB, JEDEC Standard Test Boards	47.9°C/W	42.1°C/W	39.4°C/W

**NOTE:** Most modern PCB designs use multi-layered boards. The data in the second row pertains to most designs.

### TRANSISTOR COUNT

The transistor count for ICS8521 is: 944

PACKAGE OUTLINE - Y SUFFIX FOR 32 LEAD LQFP

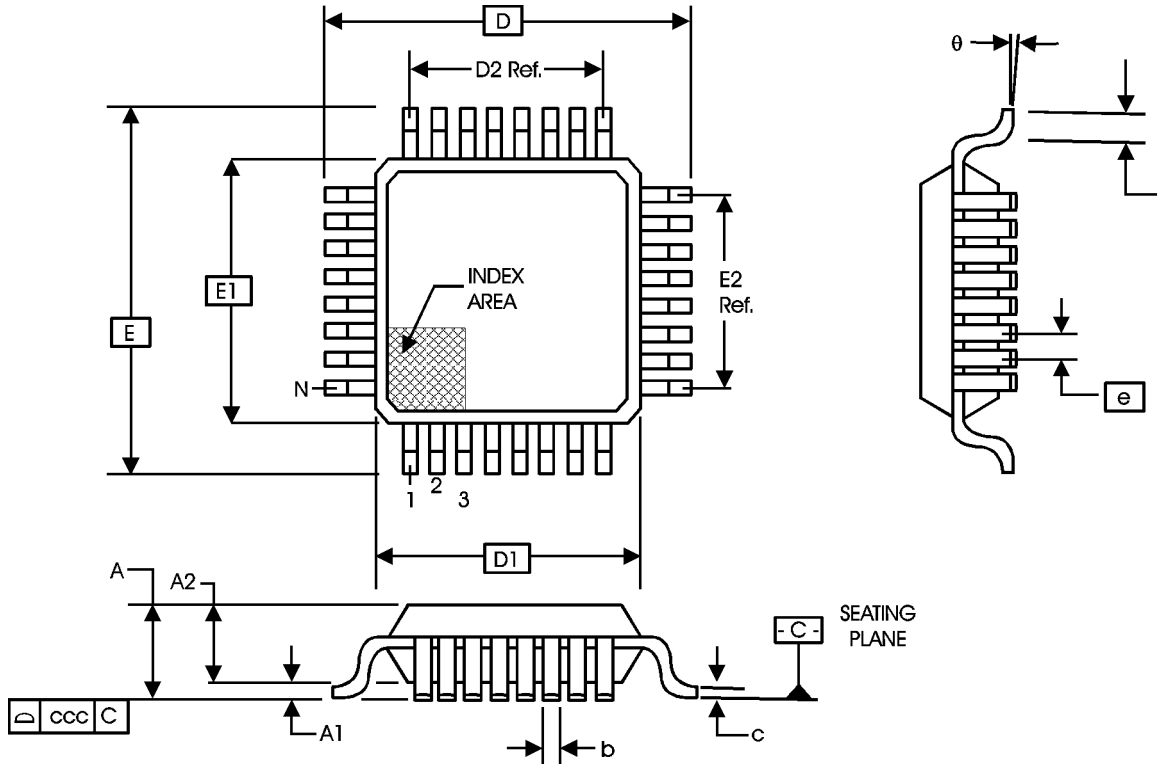

TABLE 6. PACKAGE DIMENSIONS

JEDEC VARIATION ALL DIMENSIONS IN MILLIMETERS			
SYMBOL	BBA		
	MINIMUM	NOMINAL	MAXIMUM
N	32		
A	--	--	1.60
A1	0.05	--	0.15
A2	1.35	1.40	1.45
b	0.30	0.37	0.45
c	0.09	--	0.20
D	9.00 BASIC		
D1	7.00 BASIC		
D2	5.60 Ref.		
E	9.00 BASIC		
E1	7.00 BASIC		
E2	5.60 Ref.		
e	0.80 BASIC		
L	0.45	0.60	0.75
θ	0°	--	7°
ccc	--	--	0.10

Reference Document: JEDEC Publication 95, MS-026



**ICS8521**  
LOW SKEW, 1-TO-9  
DIFFERENTIAL-TO-HSTL FANOUT BUFFER

**TABLE 7. ORDERING INFORMATION**

Part/Order Number	Marking	Package	Shipping Packaging	Temperature
8521BY	ICS8521BY	32 Lead LQFP	tray	0°C to 70°C
8521BYT	ICS8521BY	32 Lead LQFP on Tape and Reel	1000	0°C to 70°C
8521BYLN	ICS8521BYLN	32 Lead "Lead-Free/Annealed" LQFP	tray	0°C to 70°C
8521BYLNT	ICS8521BYLN	32 Lead "Lead-Free/Annealed" LQF on Tape and Reel	1000	0°C to 70°C

While the information presented herein has been checked for both accuracy and reliability, Integrated Device Technology, Inc. (IDT) assumes no responsibility for either its use or for infringement of any patents or other rights of third parties, which would result from its use. No other circuits, patents, or licenses are implied. This product is intended for use in normal commercial and industrial applications. Any other applications such as those requiring high reliability, or other extraordinary environmental requirements are not recommended without additional processing by IDT. IDT reserves the right to change any circuitry or specifications without notice. IDT does not authorize or warrant any IDT product for use in life support devices or critical medical instruments.



REVISION HISTORY SHEET				
Rev	Table	Page	Description of Change	Date
B		3	Updated Figure 1 - CLK_EN Timing Diagram.	10/16/01
B		3	Updated Figure 1 - CLK_EN Timing Diagram.	11/1/01
C	T4E	5	LVHSTL table - changed $V_{OH}$ maximum from 1.2V to 1.4V.	01/02/03
D	T2 T4B	2	Changed LVHSTL to HSTL throughout data sheet to conform with JEDEC terminology.	7/16/03
		2	Pin Characteristics table - changed CIN 4pF max. to 4pF typical.	
		4	LVC MOS table - changed VIH from 3.765V max. to VDD + 0.3V max.	
		8	Added Differential Input Interface section.	
9	Added LVPECL Input Interface section.			
D	T7	4	Absolute Maximum Ratings - updated Output rating.	7/7/04
		9	Updated LVPECL Clock Input Interface section.	
		14	Ordering Information - added "Lead-Free/Annealed" part number.	
E	T7	14	Updated datasheet's header/footer with IDT from ICS.	7/25/10
		16	Removed ICS prefix from Part/Order Number column. Added Contact Page.	



**ICS8521**  
LOW SKEW, 1-TO-9  
DIFFERENTIAL-TO-HSTL FANOUT BUFFER

---

**We've Got Your Timing Solution.**



6024 Silver Creek Valley Road  
San Jose, CA 95138

**Sales**  
800-345-7015 (inside USA)  
+408-284-8200 (outside USA)  
Fax: 408-284-2775

**Tech Support**  
netcom@idt.com

© 2010 Integrated Device Technology, Inc. All rights reserved. Product specifications subject to change without notice. IDT, the IDT logo, ICS and HiPerClockS are trademarks of Integrated Device Technology, Inc. Accelerated Thinking is a service mark of Integrated Device Technology, Inc. All other brands, product names and marks are or may be trademarks or registered trademarks used to identify products or services of their respective owners.  
Printed in USA