

2.5V or 3.3V, 200 MHz, 1:18 Clock Distribution Buffer

Features

- 200 MHz Clock Support
- 2.5V or 3.3V Operation
- LVC MOS/LVTTL Clock Input
- LVC MOS-/LVTTL-Compatible Inputs
- 18 Clock Outputs: Drive up to 36 Clock Lines
- 110 ps Typical Output-to-output Skew
- Output Enable Control
- Pin Compatible with MPC942C
- Available in Industrial and Commercial
- 32-pin LQFP package

Description

The CY29942 is a low voltage 200 MHz clock distribution buffer with an LVC MOS or LVTTL compatible input clock. All other control inputs are LVC MOS/LVTTL compatible. The eighteen outputs are 2.5V or 3.3V LVC MOS or LVTTL compatible and can drive 50Ω series or parallel terminated transmission lines. For series terminated transmission lines, each output can drive one or two traces giving the devices an effective fanout of 1:36. Low output-to-output skews make the CY29942 an ideal clock distribution buffer for nested clock trees in the most demanding of synchronous systems.

Logic Block Diagram

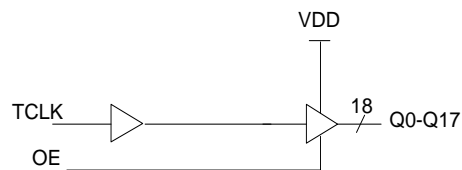

Pinouts

Figure 1. Pin Configuration

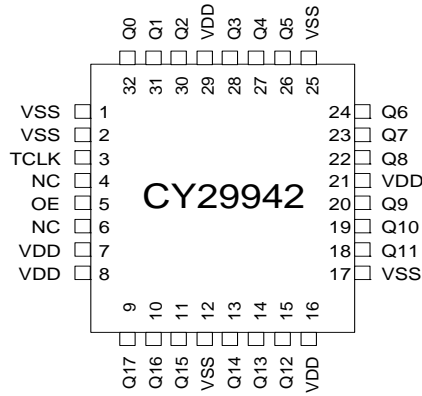

Table 1. Pin Description^[1]

Pin	Name	I/O	Description
3	TCLK	Input, PD	External Reference/Test Clock Input
5	OE	Input, PU	Output Enable. When HIGH, all outputs are enabled. When set LOW, the outputs are at high impedance.
9, 10, 11, 13, 14, 15, 18, 19, 20, 22, 23, 24, 26, 27, 28, 30, 31, 32	Q(17:0)	Output	Clock Outputs
7, 8, 16, 21, 29	VDD		3.3V or 2.5V Power Supply
1, 2, 12, 17, 25	VSS		Common Ground
4, 6	NC		No Connection

Note

1. PD = Internal Pull-Down, PU = Internal Pull-up.

Maximum Ratings^[2]

Maximum Input Voltage Relative to V_{SS} :..... $V_{SS} - 0.3V$
 Maximum Input Voltage Relative to V_{DD} :..... $V_{DD} + 0.3V$
 Storage Temperature:..... -65° to $150^{\circ}C$
 Operating Temperature:..... -40° to $85^{\circ}C$
 Maximum ESD protection..... 2 kV
 Maximum Power Supply:..... 5.5V
 Maximum Input Current:..... ± 20 mA

This device contains circuitry to protect the inputs against damage due to high static voltages or electric field; however, precautions should be taken to avoid application of any voltage higher than the maximum rated voltages to this circuit. For proper operation, V_{in} and V_{out} should be constrained to the range:

$$V_{SS} < (V_{in} \text{ or } V_{out}) < V_{DD}$$

Unused inputs must always be tied to an appropriate logic voltage level (either V_{SS} or V_{DD}).

DC Parameters

$V_{DD} = 3.3V \pm 5\%$ or $2.5V \pm 5\%$, $V_{DDC} = 3.3V \pm 5\%$ or $2.5V \pm 5\%$, Over the specified temperature range.

Parameter	Description	Conditions	Min	Typ	Max	Unit
V_{IL}	Input Low Voltage		V_{SS}		0.8	V
V_{IH}	Input High Voltage		2.0		V_{DD}	V
I_{IL}	Input Low Current ^[3]				-200	μA
I_{IH}	Input High Current ^[3]				200	μA
V_{OL}	Output Low Voltage ^[4]	$I_{OL} = 20$ mA			0.5	V
V_{OH}	Output High Voltage ^[4]	$I_{OH} = -20$ mA, $V_{DDC} = 3.3V$	2.4			V
		$I_{OH} = -16$ mA, $V_{DDC} = 2.5V$	2.0			
I_{DDQ}	Quiescent Supply Current			5	7	mA
I_{DD}	Dynamic Supply Current	$V_{DD} = 3.3V$, Outputs at 150 MHz, $CL = 15$ pF		285		mA
		$V_{DD} = 3.3V$, Outputs at 200 MHz, $CL = 15$ pF		335		
		$V_{DD} = 2.5V$, Outputs at 150 MHz, $CL = 15$ pF		200		
		$V_{DD} = 2.5V$, Outputs at 200 MHz, $CL = 15$ pF		240		
Z_{out}	Output Impedance	$V_{DD} = 3.3V$	8	12	16	Ω
		$V_{DD} = 2.5V$	10	15	20	
C_{in}	Input Capacitance			4		pF

Notes

- 2. **Multiple Supplies:** The Voltage on any input or I/O pin cannot exceed the power pin during power-up. Power supply sequencing is NOT required.
- 3. Inputs have pull-up/pull-down resistors that effect input current.
- 4. Driving series or parallel terminated 50 Ω (or 50 Ω to $V_{DD}/2$) transmission lines.

AC Parameters

$V_{DD} = 3.3V \pm 5\%$ or $2.5V \pm 5\%$, $V_{DDC} = 3.3V \pm 5\%$ or $2.5V \pm 5\%$, Over the specified temperature range^[5]

Parameter	Description	Conditions	Min	Typ	Max	Unit
Fmax	Input Frequency				200	MHz
Tpd	TTL_CLK to Q Delay ^[6, 7]	$V_{DD} = 3.3V$	1.8	3.3	3.8	ns
		$V_{DD} = 2.5V$	2.3	3.8	4.4	
FoutDC	Output Duty Cycle ^[6, 7, 8]	Measured at $V_{DD}/2$	45		55	%
Tskew	Output-to-Output Skew ^[6, 7]			110	200	ps
Tskew(pp)	Part-to-Part Skew ^[9]	$V_{DD} = 3.3V$			1.0	ns
		$V_{DD} = 2.5V$			1.3	
Tskew(pp)	Part-to-Part Skew ^[10]				600	ps
Tr/Tf	Output Clocks Rise/Fall Time ^[6, 7]	0.8V to 2.0V, $V_{DD} = 3.3V$	0.2		1.1	ns
		0.5V to 1.8V, $V_{DD} = 2.5V$				

Notes

- 5. Parameters are guaranteed by design and characterization. Not 100% tested in production. All parameters specified with loaded outputs.
- 6. Outputs driving 50Ω transmission lines.
- 7. See Figure 2.
- 8. 50% input duty cycle.
- 9. Across temperature and voltage ranges, includes output skew.
- 10. For a specific temperature and voltage, includes output skew.

Figure 2. LVCMOS_CLK CY29942 Test Reference for VCC = 3.3V and VCC = 2.5V

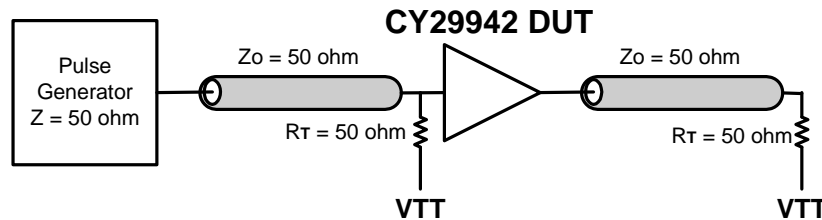

Figure 3. LVCMOS Propagation Delay (TPD) Test Reference

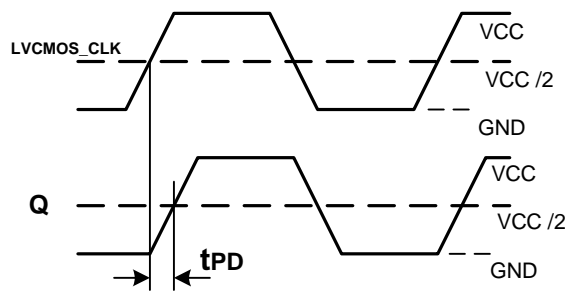

Figure 4. Output Duty Cycle (FoutDC)

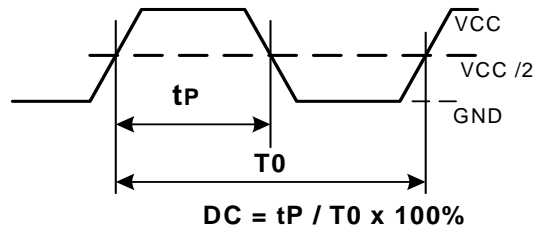

Figure 5.

Figure 6. Output-to-Output Skew tsk(0)

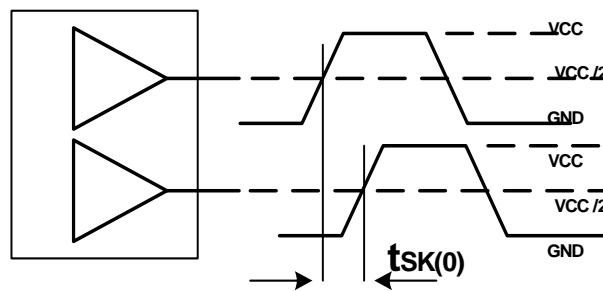

Figure 7.

Ordering Information

Part Number	Package Type	Production Flow
CY29942AI	32-Pin LQFP	Industrial, -40° to 85°C
CY29942AIT	32-Pin LQFP – Tape and Reel	Industrial, -40° to 85°C
CY29942AC	32-Pin LQFP	Commercial, 0° to 70°C
Pb-free		
CY29942AXI	32-Pin LQFP	Industrial, -40° to 85°C
CY29942AXIT	32-Pin LQFP – Tape and Reel	Industrial, -40° to 85°C
CY29942AXC	32-Pin LQFP	Commercial, 0° to 70°C
CY29942AXCT	32-Pin LQFP – Tape and Reel	Commercial, 0° to 70°C

Package Drawing and Dimensions

32-Pin Thin Plastic Quad Flatpack 7 x 7 x 1.4 mm A32.14

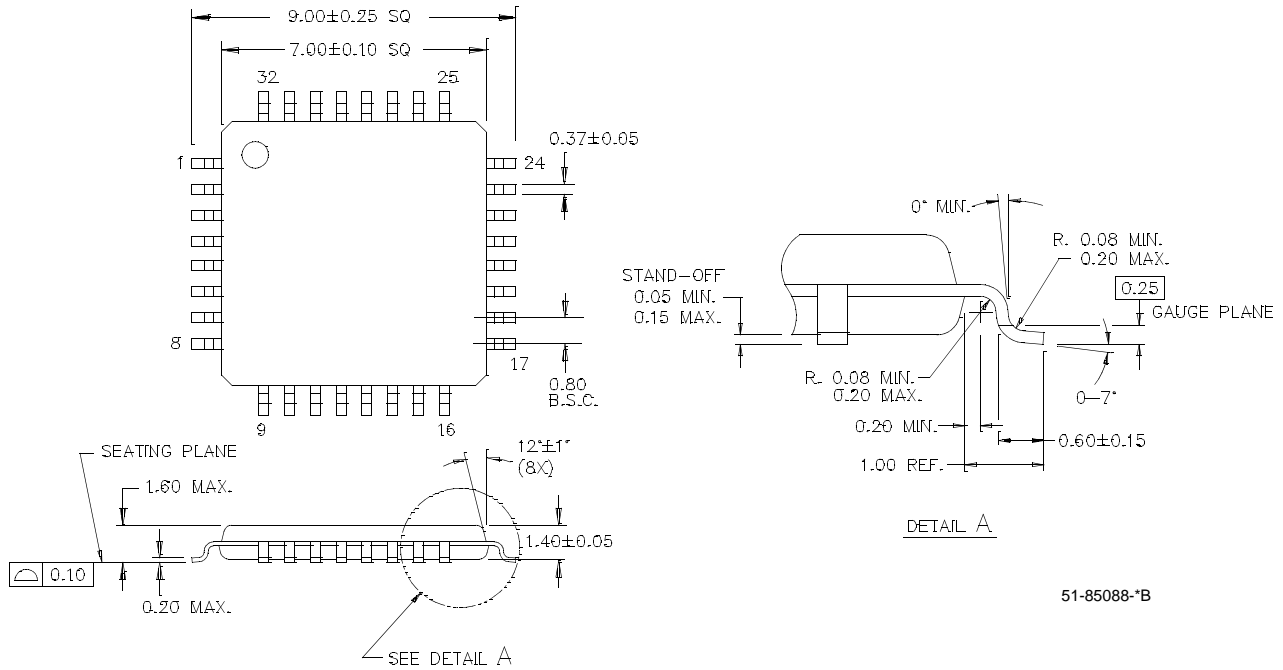

Document History Page

Document Title: CY29942 2.5V or 3.3V, 200 MHz, 1:18 Clock Distribution Buffer Document Number: 38-07284				
Revision	ECN	Orig. of Change	Submission Date	Description of Change
**	111095	BRK	02/07/02	New datasheet
*A	116777	HWT	08/14/02	Added a Commercial Temp. Range in the Ordering Information
*B	122876	RBI	12/21/02	Add power up requirements to maximum rating information.
*C	334117	RGL	See ECN	Added Lead-free devices Added typical value for output-output skew
*D	2761988	KVM	09/10/09	Ordering Information table: fixed typo and removed obsolete CY29942ACT. Changed Lead-free to Pb-free.

Sales, Solutions, and Legal Information

Worldwide Sales and Design Support

Cypress maintains a worldwide network of offices, solution centers, manufacturer's representatives, and distributors. To find the office closest to you, visit us at cypress.com/sales.

Products

PSoC	psoc.cypress.com
Clocks & Buffers	clocks.cypress.com
Wireless	wireless.cypress.com
Memories	memory.cypress.com
Image Sensors	image.cypress.com

© Cypress Semiconductor Corporation, 2002-2009. The information contained herein is subject to change without notice. Cypress Semiconductor Corporation assumes no responsibility for the use of any circuitry other than circuitry embodied in a Cypress product. Nor does it convey or imply any license under patent or other rights. Cypress products are not warranted nor intended to be used for medical, life support, life saving, critical control or safety applications, unless pursuant to an express written agreement with Cypress. Furthermore, Cypress does not authorize its products for use as critical components in life-support systems where a malfunction or failure may reasonably be expected to result in significant injury to the user. The inclusion of Cypress products in life-support systems application implies that the manufacturer assumes all risk of such use and in doing so indemnifies Cypress against all charges.

Any Source Code (software and/or firmware) is owned by Cypress Semiconductor Corporation (Cypress) and is protected by and subject to worldwide patent protection (United States and foreign), United States copyright laws and international treaty provisions. Cypress hereby grants to licensee a personal, non-exclusive, non-transferable license to copy, use, modify, create derivative works of, and compile the Cypress Source Code and derivative works for the sole purpose of creating custom software and or firmware in support of licensee product to be used only in conjunction with a Cypress integrated circuit as specified in the applicable agreement. Any reproduction, modification, translation, compilation, or representation of this Source Code except as specified above is prohibited without the express written permission of Cypress.

Disclaimer: CYPRESS MAKES NO WARRANTY OF ANY KIND, EXPRESS OR IMPLIED, WITH REGARD TO THIS MATERIAL, INCLUDING, BUT NOT LIMITED TO, THE IMPLIED WARRANTIES OF MERCHANTABILITY AND FITNESS FOR A PARTICULAR PURPOSE. Cypress reserves the right to make changes without further notice to the materials described herein. Cypress does not assume any liability arising out of the application or use of any product or circuit described herein. Cypress does not authorize its products for use as critical components in life-support systems where a malfunction or failure may reasonably be expected to result in significant injury to the user. The inclusion of Cypress' product in a life-support systems application implies that the manufacturer assumes all risk of such use and in doing so indemnifies Cypress against all charges.

Use may be limited by and subject to the applicable Cypress software license agreement.