

PKY 4000 PI series DC/DC converters, Input 36-75 V, Output up to 25 A/700 W	EN/LZT 146 380 R2A Oct 2008 © Ericsson Power Modules AB
--	--

Key Features

- Full-brick Industry Standard
116.8 x 61.0 x 12.7 mm (4.6 x 2.4 x 0.50 in.)
- High efficiency, typ. 95 % at 28 Vout within 30%-100% load range.
- 1500 Vdc input to output isolation
- Meets isolation requirements equivalent to basic insulation according to IEC/EN/UL 60950
- 1 million hours MTBF

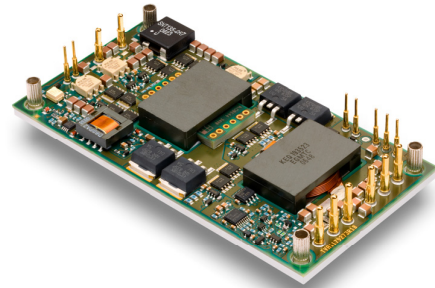

General Characteristics

- Excellent thermal performance
- Output over voltage protection
- Input over voltage protection
- Input under voltage shutdown
- Over temperature protection
- Monotonic startup
- Remote sense
- Remote control
- Over current protection
- Output voltage adjust function
- Power Good Function.
- AUX voltage 10V, 50mA
- Highly automated manufacturing ensures quality
- ISO 9001/14001 certified supplier

Safety Approvals



Design for Environment



Meets requirements in high-temperature lead-free soldering processes.

Contents

General Information	2
Safety Specification	3
Absolute Maximum Ratings	4
Product Program	Ordering No.
28 V, 21.5A / 600W Electrical Specification	PKY 4616 PI 5
28 V, 25A / 700W Electrical Specification	PKY 4716 PI 9
EMC Specification	13
Operating Information	14
Thermal Consideration	16
Connections	17
Mechanical Information	18
Soldering Information	19
Delivery Information	19
Product Qualification Specification	20

PKY 4000 PI series DC/DC converters, Input 36-75 V, Output up to 25 A/700 W	EN/LZT 146 380 R2A Oct 2008
	© Ericsson Power Modules AB

General Information

Ordering Information

See Contents for individual product ordering numbers.

Option	Suffix	Ordering No.
Standard		PKY 4716 PI
Non-threaded stand off	M	PKY 4716 PIM
Negative Remote Control logic	N	PKY 4716 PIN

Note: As an example a negative logic with non-threaded stand off product would be PKY 4716 PINM.

Reliability

The Mean Time Between Failure (MTBF) is calculated at full output power and an operating ambient temperature (T_A) of +40°C, which is a typical condition in Information and Communication Technology (ICT) equipment. Different methods could be used to calculate the predicted MTBF and failure rate which may give different results. Ericsson Power Modules currently uses Telcordia SR332.

Predicted MTBF for the series is:

- 1 million hours according to Telcordia SR332, issue 1, Black box technique.

Telcordia SR332 is a commonly used standard method intended for reliability calculations in ICT equipment. The parts count procedure used in this method was originally modelled on the methods from MIL-HDBK-217F, Reliability Predictions of Electronic Equipment. It assumes that no reliability data is available on the actual units and devices for which the predictions are to be made, i.e. all predictions are based on generic reliability parameters.

Compatibility with RoHS requirements

The products are compatible with the relevant clauses and requirements of the RoHS directive 2002/95/EC and have a maximum concentration value of 0.1% by weight in homogeneous materials for lead, mercury, hexavalent chromium, PBB and PBDE and of 0.01% by weight in homogeneous materials for cadmium.

Exemptions in the RoHS directive utilized in Ericsson Power Modules products include:

- Lead in high melting temperature type solder (used to solder the die in semiconductor packages)
- Lead in glass of electronics components and in electronic ceramic parts (e.g. fill material in chip resistors)
- Lead as an alloying element in copper alloy containing up to 4% lead by weight (used in connection pins made of Brass)

Quality Statement

The products are designed and manufactured in an industrial environment where quality systems and methods like ISO 9000, 6 σ (sigma), and SPC are intensively in use to boost the continuous improvements strategy. Infant mortality or early failures in the products are screened out and they are subjected to an ATE-based final test. Conservative design rules, design reviews and product qualifications, plus the high competence of an engaged work force, contribute to the high quality of our products.

Warranty

Warranty period and conditions are defined in Ericsson Power Modules General Terms and Conditions of Sale.

Limitation of Liability

Ericsson Power Modules does not make any other warranties, expressed or implied including any warranty of merchantability or fitness for a particular purpose (including, but not limited to, use in life support applications, where malfunctions of product can cause injury to a person's health or life).

PKY 4000 PI series	EN/LZT 146 380 R2A Oct 2008
DC/DC converters, Input 36-75 V, Output up to 25 A/700 W	© Ericsson Power Modules AB

Safety Specification

General information

Ericsson Power Modules DC/DC converters and DC/DC regulators are designed in accordance with safety standards IEC/EN/UL60950, *Safety of Information Technology Equipment*.

IEC/EN/UL60950 contains requirements to prevent injury or damage due to the following hazards:

- Electrical shock
- Energy hazards
- Fire
- Mechanical and heat hazards
- Radiation hazards
- Chemical hazards

On-board DC-DC converters and DC/DC regulators are defined as component power supplies. As components they cannot fully comply with the provisions of any Safety requirements without "Conditions of Acceptability". Clearance between conductors and between conductive parts of the component power supply and conductors on the board in the final product must meet the applicable Safety requirements. Certain conditions of acceptability apply for component power supplies with limited stand-off (see Mechanical Information for further information). It is the responsibility of the installer to ensure that the final product housing these components complies with the requirements of all applicable Safety standards and Directives for the final product.

Component power supplies for general use should comply with the requirements in IEC60950, EN60950 and UL60950 "*Safety of information technology equipment*". There are other more product related standards, e.g. IEEE802.3af "Ethernet LAN/MAN Data terminal equipment power", and ETS300132-2 "Power supply interface at the input to telecommunications equipment; part 2: DC", but all of these standards are based on IEC/EN/UL60950 with regards to safety.

Ericsson Power Modules DC/DC converters and DC/DC regulators are UL60950 recognized and certified in accordance with EN60950.

The flammability rating for all construction parts of the products meets requirements for V-0 class material according to IEC 60695-11-10.

The products should be installed in the end-use equipment, in accordance with the requirements of the ultimate application. Normally the output of the DC/DC converter is considered as SELV (Safety Extra Low Voltage) and the input source must be isolated by minimum Double or Reinforced Insulation from the primary circuit (AC mains) in accordance with IEC/EN/UL60950.

Isolated DC/DC converters

It is recommended that a slow blow fuse with a rating twice the maximum input current per selected product be used at the input of each DC/DC converter. If an input filter is used in the circuit the fuse should be placed in front of the input filter.

In the rare event of a component problem in the input filter or in the DC/DC converter that imposes a short circuit on the input source, this fuse will provide the following functions:

- Isolate the faulty DC/DC converter from the input power source so as not to affect the operation of other parts of the system.
- Protect the distribution wiring from excessive current and power loss thus preventing hazardous overheating.

The galvanic isolation is verified in an electric strength test. The test voltage (V_{iso}) between input and output is 1500 Vdc or 2250 Vdc for 60 seconds (refer to product specification).

Leakage current is less than 1 μ A at nominal input voltage.

24 V DC systems

The input voltage to the DC/DC converter is SELV (Safety Extra Low Voltage) and the output remains SELV under normal and abnormal operating conditions.

48 and 60 V DC systems

If the input voltage to the DC/DC converter is 75 Vdc or less, then the output remains SELV (Safety Extra Low Voltage) under normal and abnormal operating conditions.

Single fault testing in the input power supply circuit should be performed with the DC/DC converter connected to demonstrate that the input voltage does not exceed 75 Vdc.

If the input power source circuit is a DC power system, the source may be treated as a TNV2 circuit and testing has demonstrated compliance with SELV limits and isolation requirements equivalent to Basic Insulation in accordance with IEC/EN/UL60950.

Non-isolated DC/DC regulators

The input voltage to the DC/DC regulator is SELV (Safety Extra Low Voltage) and the output remains SELV under normal and abnormal operating conditions.

PKY 4000 PI series	EN/LZT 146 380 R2A Oct 2008
DC/DC converters, Input 36-75 V, Output up to 25 A/700 W	© Ericsson Power Modules AB

Absolute Maximum Ratings

Characteristics		min	typ	max	Unit
T_{P1}	Operating Temperature (see Thermal Consideration section)	-40		+100	°C
T_S	Storage temperature	-55		+125	°C
V_I	Input voltage	-0.5		+100	V
V_{iso}	Isolation voltage (input to output test voltage)	1500			Vdc
V_{tr}	Input voltage transient (t_p 100 ms)			100	V
V_{RC}	Remote Control pin voltage (see Operating Information section)	Positive logic option		+12	V
		Negative logic option	-100	+12	V
V_{adj}	Adjust pin voltage (see Operating Information section)	-0.5		+10	V

Stress in excess of Absolute Maximum Ratings may cause permanent damage. Absolute Maximum Ratings, sometimes referred to as no destruction limits, are normally tested with one parameter at a time exceeding the limits of Output data or Electrical Characteristics. If exposed to stress above these limits, function and performance may degrade in an unspecified manner.

Fundamental Circuit Diagram

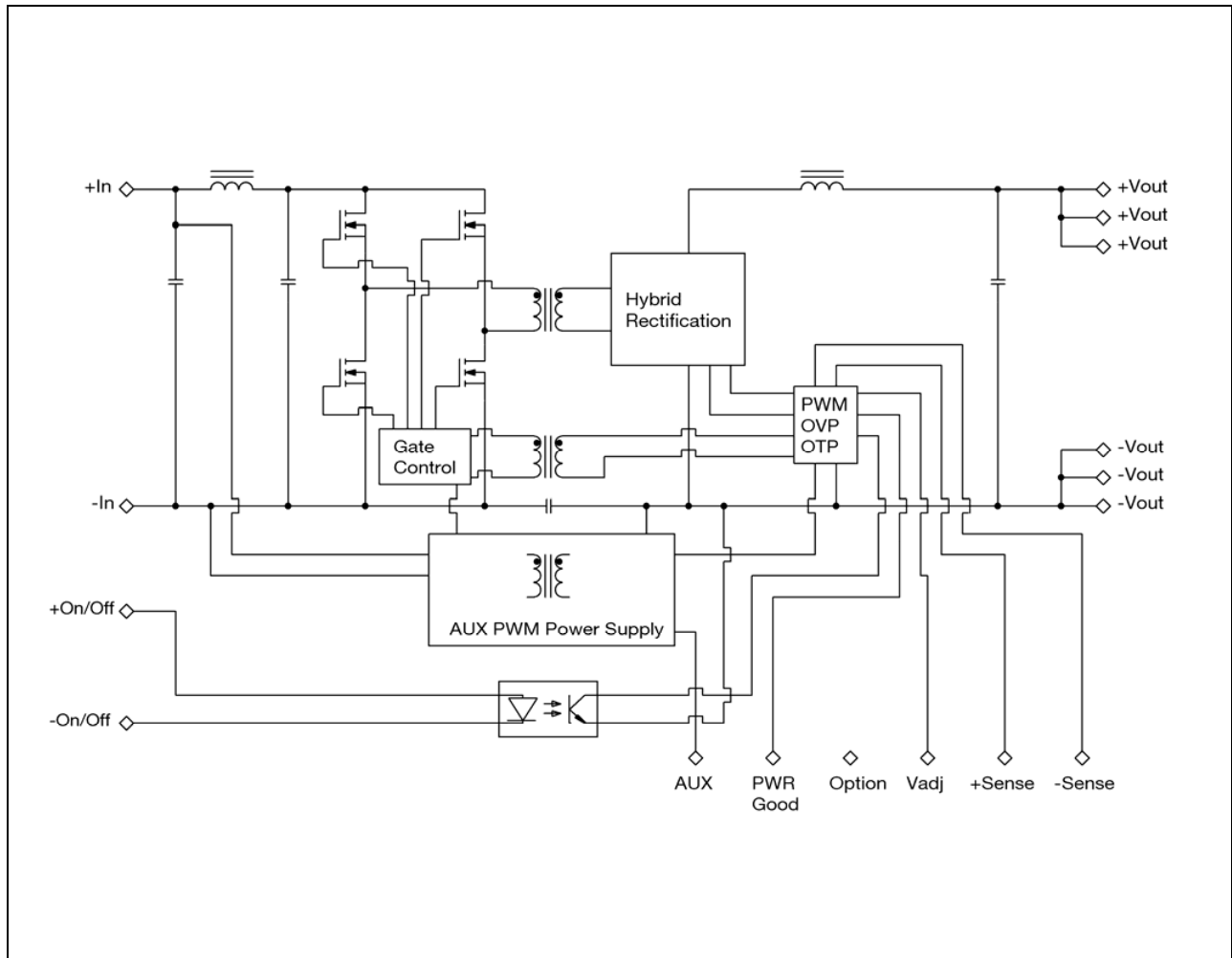

PKY 4000 PI series DC/DC converters, Input 36-75 V, Output up to 25 A/700 W	EN/LZT 146 380 R2A Oct 2008
	© Ericsson Power Modules AB

28V, 21.5A/600W Electrical Specification
PKY 4616 PI

$T_{P1} = -40$ to $+100^{\circ}\text{C}$, $V_I = 36$ to 75 V, sense pins connected to output pins unless otherwise specified under Conditions.
 Typical values given at: $T_{P1} = +25^{\circ}\text{C}$, $V_I = 53$ V, $I_O = \text{max } I_O$, unless otherwise specified under Conditions.
 Additional $C_{in} = 220$ μF . See Operating Information section for selection of capacitor types.

Characteristics		Conditions	min	typ	max	Unit
V_I	Input voltage range		36		75	V
V_{loff}	Turn-off input voltage	Decreasing input voltage	32.1	33	34.5	V
V_{lon}	Turn-on input voltage	Increasing input voltage	33.3	35	35.5	V
C_I	Internal input capacitance			35.2		μF
P_O	Output power		0		600	W
η	Efficiency	50 % of max I_O		95		%
		max I_O	93.5	94.5		
		50 % of max I_O , $V_I = 48$ V		95		
		max I_O , $V_I = 48$ V	93.5	94.5		
P_d	Power Dissipation	max I_O		34.9	41.7	W
P_{ii}	Input idling power	$I_O = 0$ A, $V_I = 53$ V		5.7	17	W
P_{RC}	Input standby power	$V_I = 53$ V (turned off with RC)		0.2	0.3	W
f_s	Switching frequency	0-100 % of max I_O	145	150	155	kHz
V_{IOVP}	Input over voltage protection	0-100 % of max I_O	80	83	86	V

V_{OI}	Output voltage initial setting and accuracy	$T_{P1} = +25^{\circ}\text{C}$, $V_I = 53$ V, $I_O = 21.5$ A	27.72	28.0	28.28	V
V_O	Output adjust range	See operating information	15.0		32.0	V
	Output voltage tolerance band	10-100 % of max I_O	27.58		28.42	V
	Idling voltage	$I_O = 0$ A	27.44		28.56	V
	Line regulation	max I_O		20	80	mV
	Load regulation	$V_I = 53$ V, 1-100 % of max I_O		20	80	mV
V_{tr}	Load transient voltage deviation	$V_I = 53$ V, Load step 25-75-25 % of max I_O , $di/dt = 1$ A/ μs		± 800		mV
t_{tr}	Load transient recovery time			40		μs
t_r	Ramp-up time (from 10-90 % of V_{OI})	10-100 % of max I_O		10	20	ms
t_s	Start-up time (from V_I connection to 90 % of V_{OI})			17	20	ms
t_f	V_I shut-down fall time (from V_I off to 10 % of V_O)	max I_O		0.06		ms
		$I_O = 0$ A		2.7		s
t_{RC}	RC start-up time	max I_O		15		ms
	RC shut-down fall time (from RC off to 10 % of V_O)	max I_O		0.06		ms
		$I_O = 0$ A		2.7		s
I_O	Output current		0		21.5	A
I_{lim}	Current limit threshold	$T_{P1} < \text{max } T_{P1}$	22	27	33.5	A
I_{sc}	Short circuit current	$T_{P1} = 25^{\circ}\text{C}$, see Note 1		27.5	34	A
C_{out}	Recommended Capacitive Load	$T_{P1} = 25^{\circ}\text{C}$	0		TBD	μF
V_{Oac}	Output ripple & noise	See ripple & noise section, max I_O , V_{OI}		180	250	mVp-p
OVP	Over voltage protection	$T_{P1} = +25^{\circ}\text{C}$, $V_I = 53$ V, 0-100 % of max I_O	36.6	39	41.4	V
V_{aux}	Auxiliary output voltage	$T_{P1} = +25^{\circ}\text{C}$, $V_I = 53$ V, 0-100 % of max I_O	8	10	12	V
I_{aux}	Auxiliary output current	max I_O , $V_I = 36-75$ V	0		0.05	A

Note 1: See Operating Information section.

PKY 4000 PI series
DC/DC converters, Input 36-75 V, Output up to 25 A/700 W

EN/LZT 146 380 R2A Oct 2008
© Ericsson Power Modules AB

28V, 21.5A/600W Typical Characteristics

PKY 4616 PI

Efficiency

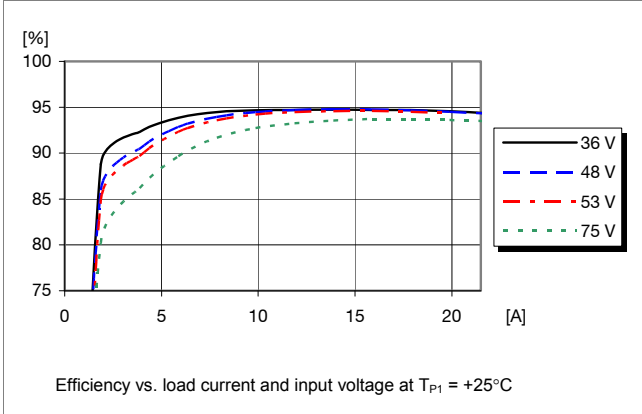

Power Dissipation

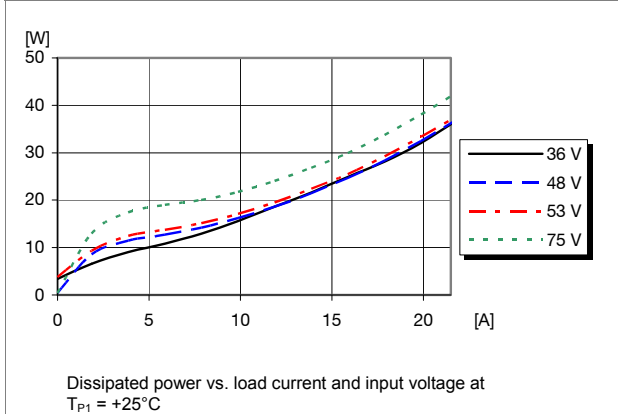

Output Characteristics

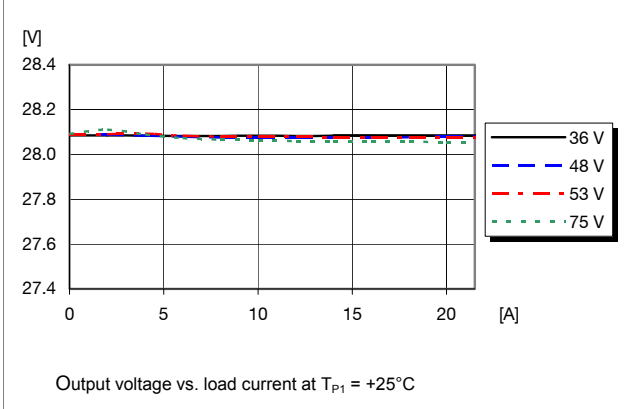

Current Limit Characteristics

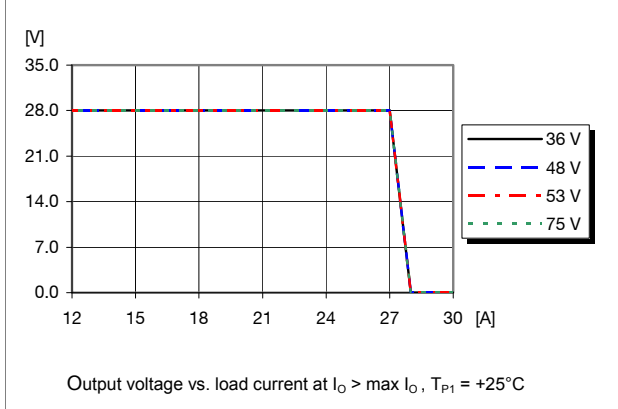

PKY 4000 PI series DC/DC converters, Input 36-75 V, Output up to 25 A/700 W	EN/LZT 146 380 R2A Oct 2008 © Ericsson Power Modules AB
--	--

28V, 21.5A/600W Typical Characteristics

PKY 4616 PI

Start-up

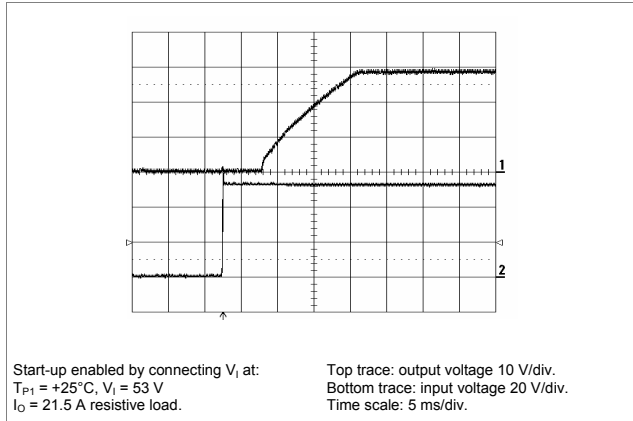

Shut-down

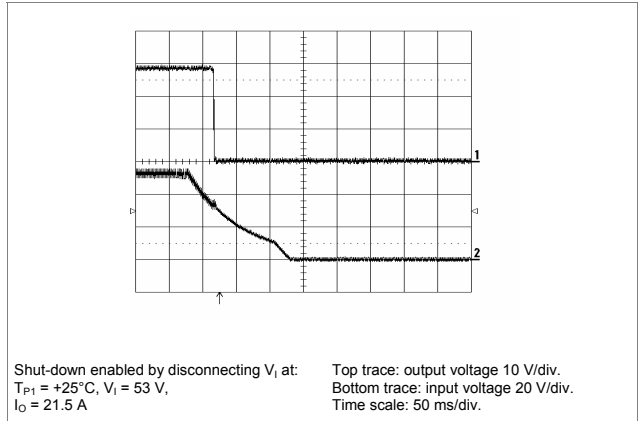

Output Ripple & Noise

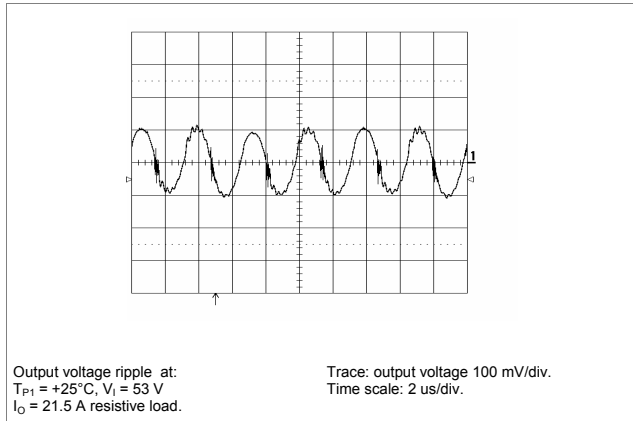

Output Load Transient Response

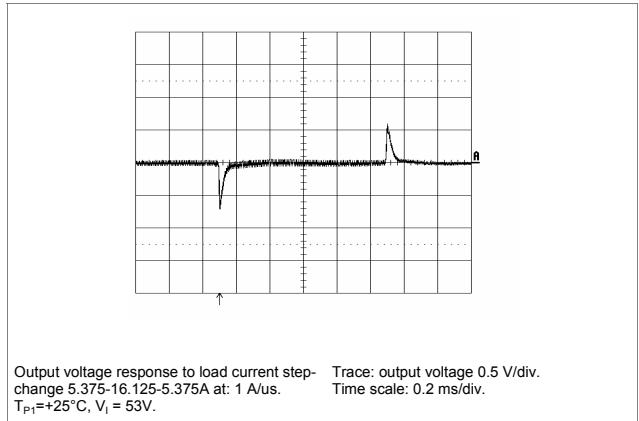

Output Voltage Adjust (see operating information)

Passive adjust

The resistor value for an adjusted output voltage is calculated by using the following equations:

Output Voltage Adjust Upwards, Increase:

$$R_{adj} = 10 \left[V_o \frac{(100 + \Delta\%) - 100 + 2 \times \Delta\%}{2.5 \times \Delta\%} \right] \text{ k}\Omega$$

Output Voltage Adjust Downwards, Decrease:

$$R_{adj} = 10 \left(\frac{100}{\Delta\%} - 2 \right) \text{ k}\Omega$$

Example: Increase 4% => $V_{out} = 29.33\text{ Vdc}$

$$10 \left[28.2 \frac{(100+4)}{2.5 \times 4} - \frac{100+2 \times 4}{4} \right] \text{ k}\Omega = 2663 \text{ k}\Omega$$

Active adjust

The output voltage may be adjusted using a current applied to the V_{adj} pin referred to -Sense. This current is calculated by using the following equations:

Output Voltage Adjust Upwards, Increase:

$$+1\% V_0 = 2,5 \times 10^{-6} \text{ A into adjust pin}$$

Output Voltage Adjust Downwards, decrease:

$$-1\% V_0 = 2,5 \times 10^{-6} \text{ A out of adjust pin}$$

PKY 4000 PI series
DC/DC converters, Input 36-75 V, Output up to 25 A/700 W

EN/LZT 146 380 R2A Oct 2008
© Ericsson Power Modules AB

28V, 21.5A/600W Typical Characteristics

PKY 4616 PI

Output Current Derating – Open frame

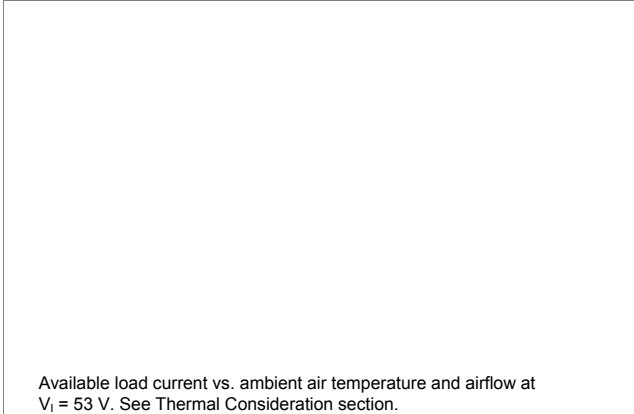

Output Current Derating – Base plate

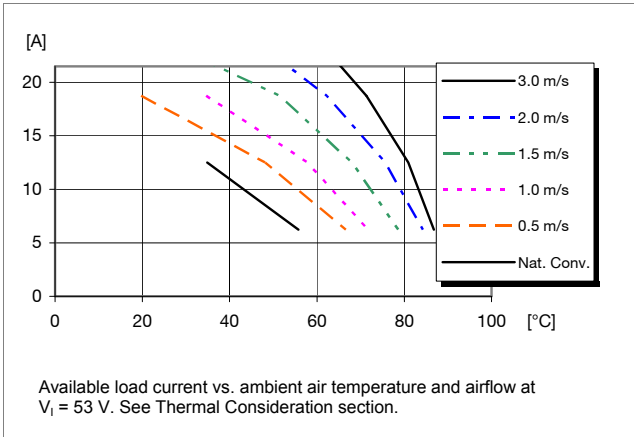

Thermal Resistance – Base plate

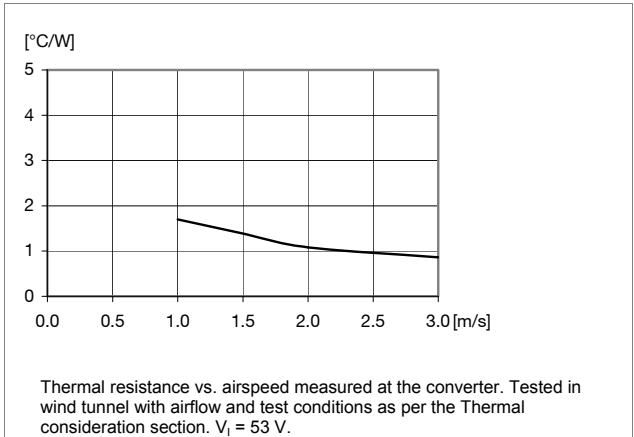

Output Current Derating – Cold wall sealed box

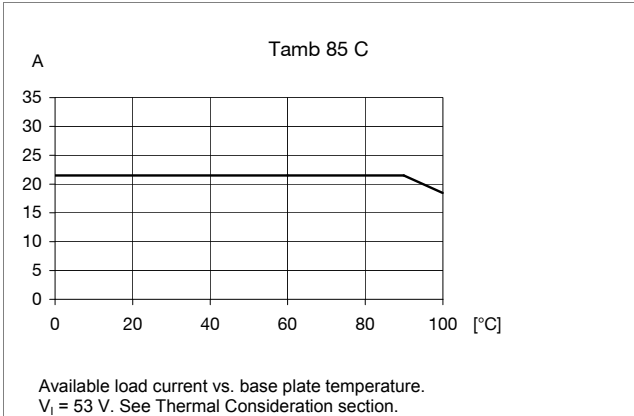

PKY 4000 PI series DC/DC converters, Input 36-75 V, Output up to 25 A/700 W	EN/LZT 146 380 R2A Oct 2008 © Ericsson Power Modules AB
--	--

28V, 25A/700W Electrical Specification

PKY 4716 PI

$T_{P1} = -40$ to $+100^{\circ}\text{C}$, $V_I = 36$ to 75 V, sense pins connected to output pins unless otherwise specified under Conditions.
 Typical values given at: $T_{P1} = +25^{\circ}\text{C}$, $V_I = 53$ V, max I_O , unless otherwise specified under Conditions.
 Additional $C_{in} = 220$ μF . See Operating Information section for selection of capacitor types.

Characteristics		Conditions	min	typ	max	Unit
V_I	Input voltage range		36		75	V
V_{loff}	Turn-off input voltage	Decreasing input voltage	32.1	33	34.5	V
V_{lon}	Turn-on input voltage	Increasing input voltage	33.3	35	35.5	V
C_I	Internal input capacitance			35.2		μF
P_O	Output power		0		700	W
η	Efficiency	50 % of max I_O		94.0		%
		max I_O	92.5	94.1		
		50 % of max I_O , $V_I = 48$ V		94.3		
		max I_O , $V_I = 48$ V	93	94.2		
P_d	Power Dissipation	max I_O		44.0	58.9	W
P_{ii}	Input idling power	$I_O = 0$ A, $V_I = 53$ V		5.7	17	W
P_{RC}	Input standby power	$V_I = 53$ V (turned off with RC)		0.2	0.3	W
f_s	Switching frequency	0-100 % of max I_O	145	150	155	kHz
V_{IOVP}	Input over voltage protection	0-100 % of max I_O	80	83	86	V

V_{OI}	Output voltage initial setting and accuracy	$T_{P1} = +25^{\circ}\text{C}$, $V_I = 53$ V, $I_O = 21.5$ A	27.72	28.0	28.28	V
V_O	Output adjust range	See operating information	15.0		32.0	V
	Output voltage tolerance band	10-100 % of max I_O	27.58		28.42	V
	Idling voltage	$I_O = 0$ A	27.44		28.56	V
	Line regulation	max I_O		20	80	mV
	Load regulation	$V_I = 53$ V, 1-100 % of max I_O		20	80	mV
V_{tr}	Load transient voltage deviation	$V_I = 53$ V, Load step 25-75-25 % of max I_O , $di/dt = 5$ A/ μs see Note 1		± 550		mV
t_{tr}	Load transient recovery time			20		μs
t_r	Ramp-up time (from 10-90 % of V_{OI})	10-100 % of max I_O		10	20	ms
t_s	Start-up time (from V_I connection to 90 % of V_{OI})			17	20	ms
t_f	V_I shut-down fall time (from $V_{I,off}$ to 10 % of V_O)	max I_O		0.06		ms
		$I_O = 0$ A		2.7		s
t_{RC}	RC start-up time	max I_O		15		ms
	RC shut-down fall time (from RC off to 10 % of V_O)	max I_O $I_O = 0$ A		0.06		ms
				2.7		s
I_O	Output current		0		25	A
I_{lim}	Current limit threshold	$T_{P1} < \text{max } T_{P1}$	26	32	37.5	A
I_{sc}	Short circuit current	$T_{P1} = 25^{\circ}\text{C}$, see Note 2		32.5	38	A
C_{out}	Recommended Capacitive Load	$T_{P1} = 25^{\circ}\text{C}$	0		TBD	μF
V_{Oac}	Output ripple & noise	See ripple & noise section, max I_O , V_{OI}		200	370	mVp-p
OVP	Over voltage protection	$T_{P1} = +25^{\circ}\text{C}$, $V_I = 53$ V, 0-100 % of max I_O	36.6	39	41.4	V
V_{aux}	Auxiliary output voltage	$T_{P1} = +25^{\circ}\text{C}$, $V_I = 53$ V, 0-100 % of max I_O	8	10	12	V
I_{aux}	Auxiliary output current	max I_O , $V_I = 36-75$ V	0		0.05	A

Note 1: C_{out} used at load transient test; 3300 μF (15 x 220 μF) electrolytic capacitors, estimated ESR < 12 m Ω

Note 2: See Operating Information section.

PKY 4000 PI series
DC/DC converters, Input 36-75 V, Output up to 25 A/700 W

EN/LZT 146 380 R2A Oct 2008
© Ericsson Power Modules AB

28V, 25A/700W Typical Characteristics

PKY 4716 PI

Efficiency

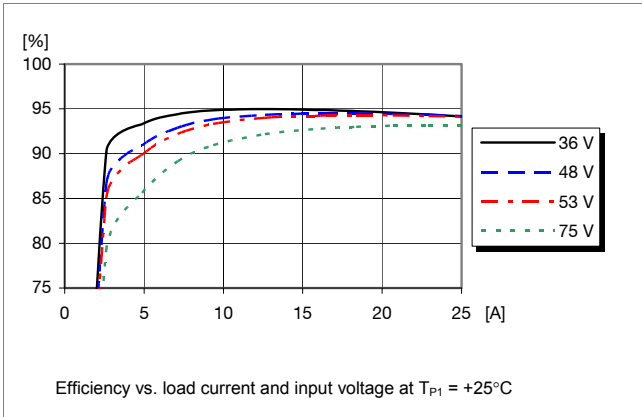

Power Dissipation

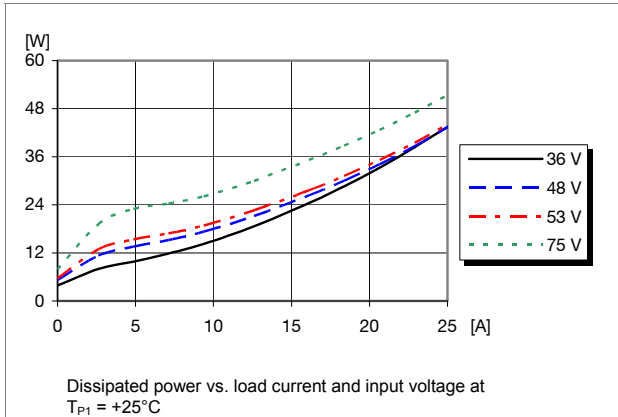

Output Characteristics

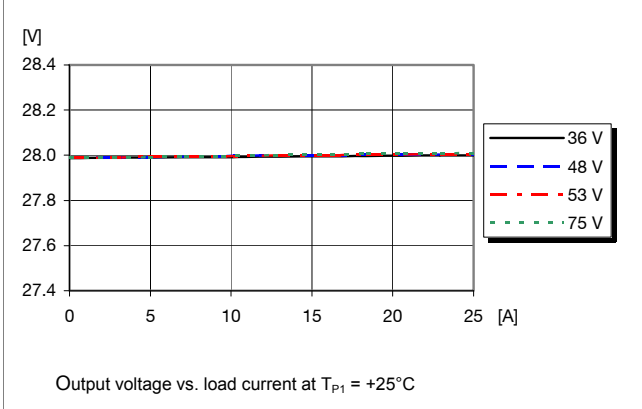

Current Limit Characteristics

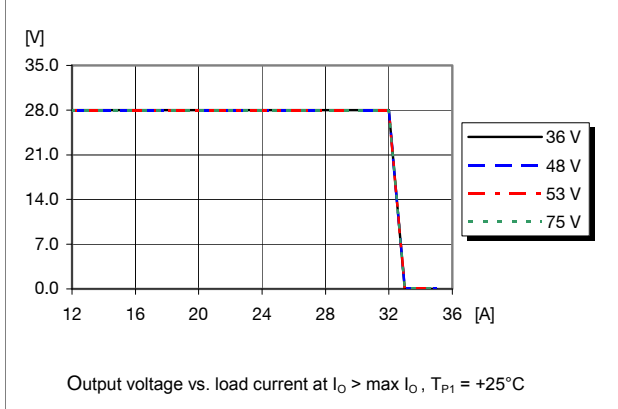

PKY 4000 PI series DC/DC converters, Input 36-75 V, Output up to 25 A/700 W	EN/LZT 146 380 R2A Oct 2008
	© Ericsson Power Modules AB

28V, 25A/700W Typical Characteristics

PKY 4716 PI

Start-up

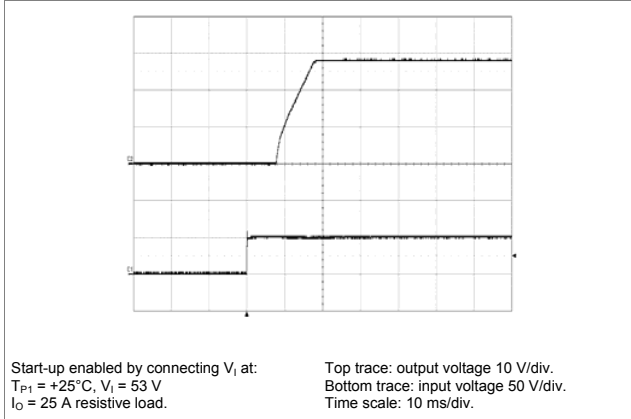

Shut-down

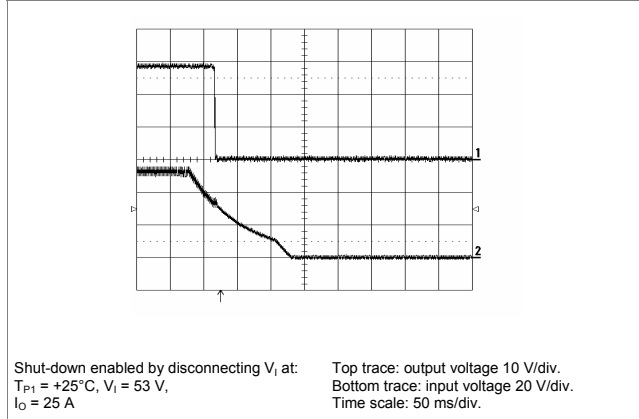

Output Ripple & Noise

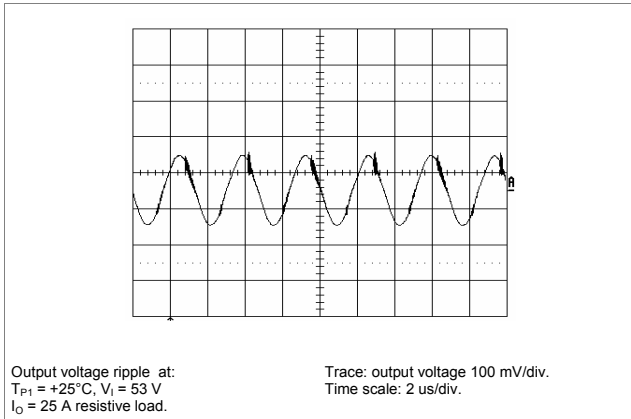

Output Load Transient Response

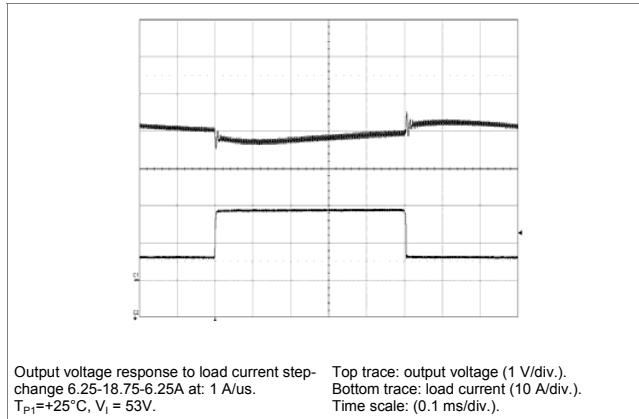

Output Voltage Adjust (see operating information)

Passive adjust

The resistor value for an adjusted output voltage is calculated by using the following equations:

Output Voltage Adjust Upwards, Increase:

$$R_{adj} = 10 \left[V_o \frac{(100 + \Delta\%) - 100 + 2 \times \Delta\%}{2.5 \times \Delta\%} - \frac{100 + 2 \times \Delta\%}{\Delta\%} \right] \text{ k}\Omega$$

Output Voltage Adjust Downwards, Decrease:

$$R_{adj} = 10 \left(\frac{100}{\Delta\%} - 2 \right) \text{ k}\Omega$$

Example: Increase 4% => $V_{out} = 29.33\text{ Vdc}$

$$10 \left[28.2 \frac{(100+4)}{2.5 \times 4} - \frac{100+2 \times 4}{4} \right] \text{ k}\Omega = 2663 \text{ k}\Omega$$

Active adjust

The output voltage may be adjusted using a current applied to the V_{adj} pin referred to -Sense. This current is calculated by using the following equations:

Output Voltage Adjust Upwards, Increase:

$$+1\% V_0 = 2,5 \times 10^{-6} \text{ A into adjust pin}$$

Output Voltage Adjust Downwards, decrease:

$$-1\% V_0 = 2,5 \times 10^{-6} \text{ A out of adjust pin}$$

PKY 4000 PI series
DC/DC converters, Input 36-75 V, Output up to 25 A/700 W

EN/LZT 146 380 R2A Oct 2008
© Ericsson Power Modules AB

28V, 25A/700W Typical Characteristics

PKY 4716 PI

Output Current Derating – Open frame

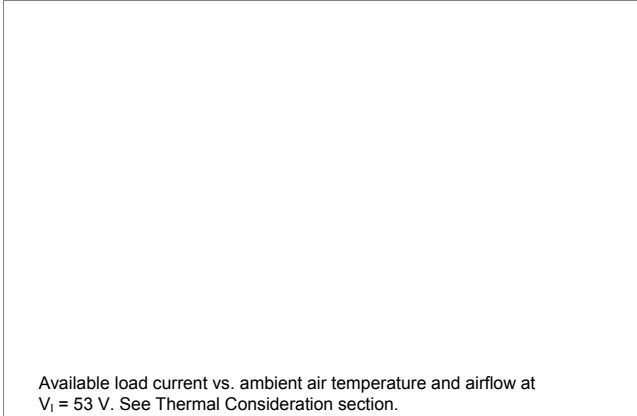

Output Current Derating – Base plate

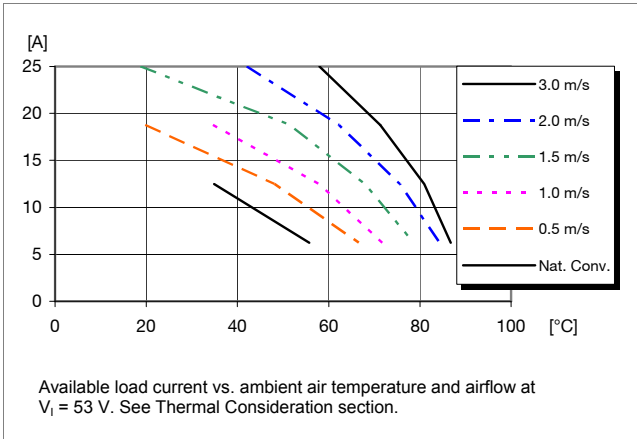

Thermal Resistance – Base plate

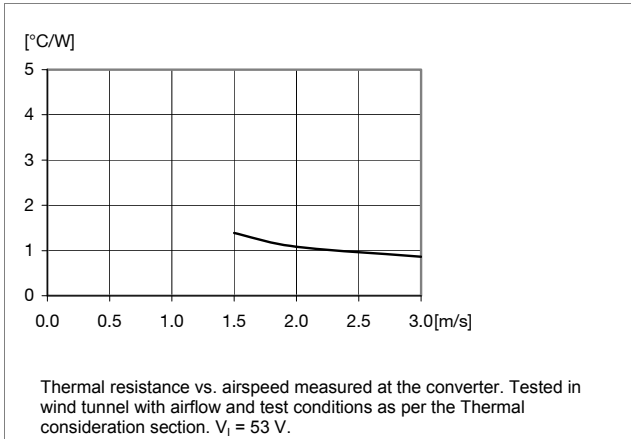

Output Current Derating – Cold wall sealed box

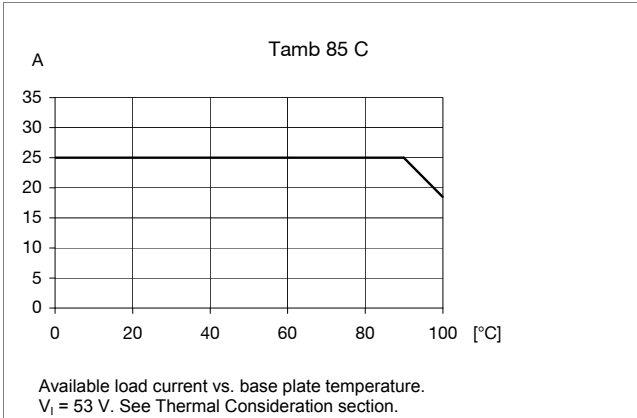

PKY 4000 PI series
DC/DC converters, Input 36-75 V, Output up to 25 A/700 W

EN/LZT 146 380 R2A Oct 2008
© Ericsson Power Modules AB

EMC Specification

Conducted EMI measured according to EN55022, CISPR 22 and FCC part 15J (see test set-up). See Design Note 009 for further information. The fundamental switching frequency is 150 kHz for PKY 4716 PI @ $V_1 = 53 V$, max I_o .

Conducted EMI Input terminal value (typ)

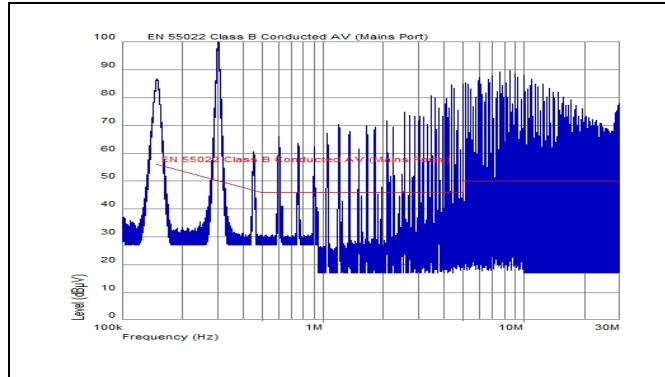

EMI without filter

External filter (class B)

Required external input filter in order to meet class B in EN 55022, CISPR 22 and FCC part 15J.

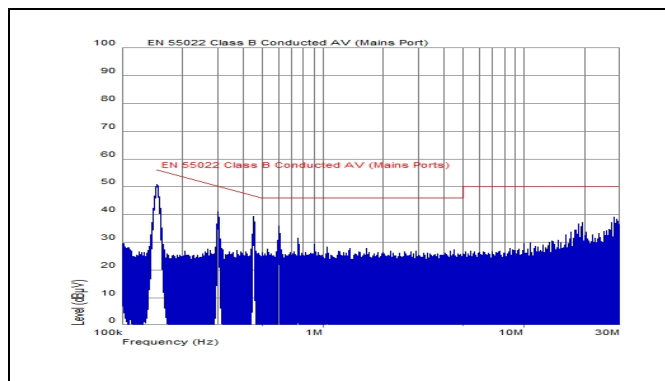
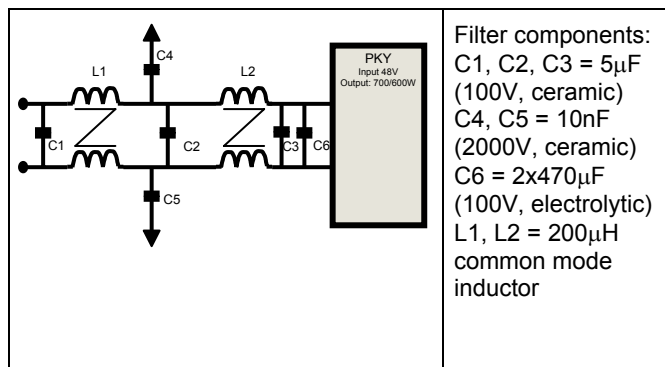

EMI with filter

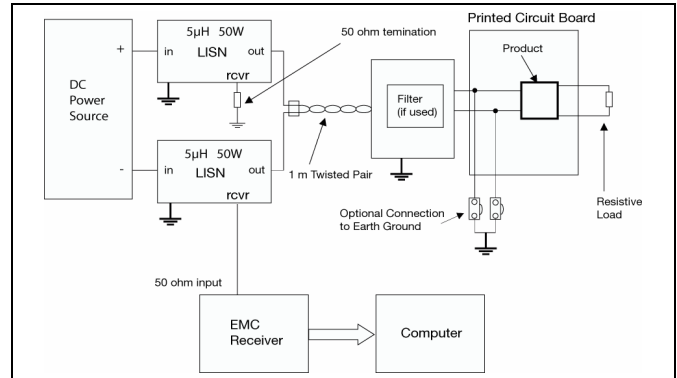

Test set-up

Layout recommendations

The radiated EMI performance of the Product will depend on the PCB layout and ground layer design. It is also important to consider the stand-off of the product. If a ground layer is used, it should be connected to the output of the product and the equipment ground or chassis.

A ground layer will increase the stray capacitance in the PCB and improve the high frequency EMC performance.

Output ripple and noise

Output ripple and noise measured according to figure below. See Design Note 022 for detailed information.

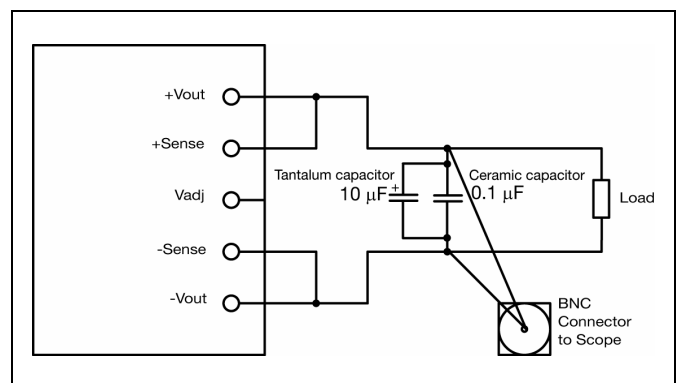

Output ripple and noise test setup

PKY 4000 PI series DC/DC converters, Input 36-75 V, Output up to 25 A/700 W	EN/LZT 146 380 R2A Oct 2008
	© Ericsson Power Modules AB

Operating information

Input Voltage

The input voltage range 36 to 75Vdc meets the requirements of the European Telecom Standard ETS 300 132-2 for normal input voltage range in -48 and -60 Vdc systems, -40.5 to -57.0 V and -50.0 to -72 V respectively. At input voltages exceeding 75 V, the power loss will be higher than at normal input voltage and T_{P1} must be limited to absolute max +100°C. The absolute maximum continuous input voltage is 100 Vdc.

Turn-off Input Voltage

The products monitor the input voltage and will turn on and turn off at predetermined levels. The minimum hysteresis between turn on and turn off input voltage is 1V.

Remote Control (RC)

The modules are equipped with a remote On/Off control function. An optocoupler in the remote control circuit provides a galvanic isolation (1500V DC minimum) between the remote control pins and the rest of the module's circuitry. Positive and negative RC logic options are available. Cycling (Off and On sequence) of the RC input will restart the module if latched after activation of the output overvoltage protection function. The standard version has a "positive logic" remote control and the module will be off until a sufficient current between the RC pins is provided.

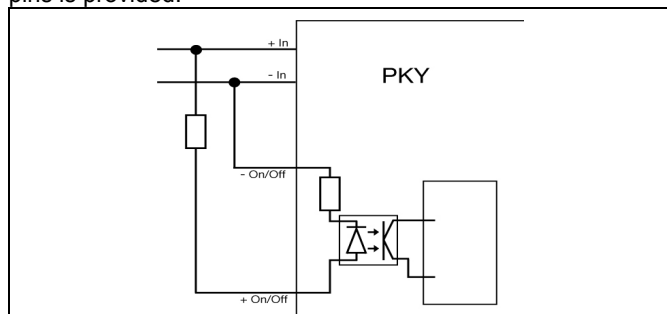

The figure above presents an example of a circuit which turns on the standard version module. The minimum current to guarantee the activation of the RC input is 1.5mA. The minimum activation voltage over the RC pins is 5.0V. To guarantee that the RC input is not activated, the current must be lower than 50µA or the voltage lower than 1.3V.

Input and Output Impedance

The impedance of both the input source and the load will interact with the impedance of the product. It is important that the input source has low characteristic impedance. The products are designed for stable operation without external capacitors connected to the input or output. The performance in some applications can be enhanced by addition of external capacitance as described under External Decoupling Capacitors.

If the input voltage source contains significant inductance, the addition of a 220 µF/100V capacitor across the input of the product will ensure stable operation. The capacitor is not required when powering the product from an input source with an inductance below 10 µH. The minimum required capacitance value depends on the output power and the input voltage. The higher output power the higher input capacitance is needed. Approximately doubled capacitance value is required for a 24 V input voltage source compared to a 48V input voltage source.

External Decoupling Capacitors

When powering loads with significant dynamic current requirements, the voltage regulation at the point of load can be improved by addition of decoupling capacitors at the load. The most effective technique is to locate low ESR ceramic and electrolytic capacitors as close to the load as possible, using several parallel capacitors to lower the effective ESR. The ceramic capacitors will handle high-frequency dynamic load changes while the electrolytic capacitors are used to handle low frequency dynamic load changes. It is equally important to use low resistance and low inductance PCB layouts and cabling.

External decoupling capacitors will become part of the product's control loop. The control loop is optimized for a wide range of external capacitance and the maximum recommended value that could be used without any additional analysis is found in the Electrical specification. The ESR of the capacitors is a very important parameter. Stable operation is guaranteed with a verified ESR value of >10 mΩ across the output connections. For further information please contact your local Ericsson Power Modules representative.

Output Voltage Adjust (V_{adj})

The products have an Output Voltage Adjust pin (V_{adj}). This pin can be used to adjust the output voltage above or below Output voltage initial setting. When increasing the output voltage, the voltage at the output pins (including any remote sense compensation) must be kept below the threshold of the over voltage protection, (OVP) to prevent the product from shutting down. At increased output voltages the maximum power rating of the product remains the same, and the max output current must be decreased correspondingly. When V_{out} is 15V, the max output current is 25A for PKY4716, that is to say, the power is 375W.

To increase the voltage the resistor should be connected between the V_{adj} pin and +Sense pin. The resistor value of the Output voltage adjust function is according to information given under the Output section for the respective product. To decrease the output voltage, the resistor should be connected between the V_{adj} pin and -Sense pin.

PKY 4000 PI series
DC/DC converters, Input 36-75 V, Output up to 25 A/700 W

EN/LZT 146 380 R2A Oct 2008

© Ericsson Power Modules AB

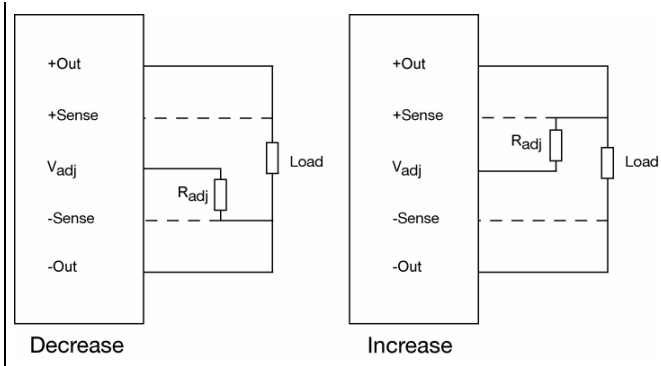

current.

Pre-bias Start-up

The module is able to start-up properly under pre-bias output condition. During the start-up, the module does not sink current from an external pre-bias source present at the output terminals.

Power Good

“Power Good” function is provided. It is a “negative logic” open collector output which can drive to “low” an external circuit when the module operates normally. The PG output will turn level “high” during fault conditions (e.g. over temperature or over voltage) or when the output is turned off with the remote control.

Auxiliary output voltage (AUX)

The module provides a power source referred to – sense terminal. It is intended to be used as a power source for external circuits, e.g. remote control. The auxiliary output voltage is active whenever an input voltage in range between from 35V to 80V is provided.

The nominal auxiliary output voltage is 10V. Maximum allowed load is 50mA. The auxiliary output source is not short circuit protected. If it is overloaded, the main converter will be switched off.

An example of a 5V/45mA power supply driven by the auxiliary output voltage is given in the figure below.

Operating information continued

Parallel Operation

Two or more products may be paralleled for redundancy or increased output power. External active load sharing circuit are recommended to provide the maximum balanced current sharing.

Remote Sense

The products have remote sense that can be used to compensate for voltage drops between the output and the point of load. The sense traces should be located close to the PCB ground layer to reduce noise susceptibility. The remote sense circuitry will compensate for up to 10% voltage drop between output pins and the point of load.

If the remote sense is not needed +Sense should be connected to +Out and -Sense should be connected to -Out.

Over Temperature Protection (OTP)

The product is protected from thermal overload by an internal Over Temperature Protection circuit (OTP). When the PCB temperature (TC reference point) exceeds the OTP T threshold value, the output voltage will be gradually decreased. This will decrease the power loss inside the DC/DC power module and protect the module from hazardous temperatures.

Over Voltage Protection (OVP)

The module includes an output Over Voltage Protection (OVP) function. In the unlikely event of an output over voltage condition, the OVP circuit will shut down the output voltage. The module will be latched in “Off” state unless either the input voltage or RC input is cycled (switched Off and On again).

Over Current Protection (OCP)

The module include current limiting circuitry for protection at continuous overload.

In case of overload, the output voltage will significantly decrease. The converter will resume normal operation after removal of the overload. The load distribution should be designed for the maximum specified output short circuit

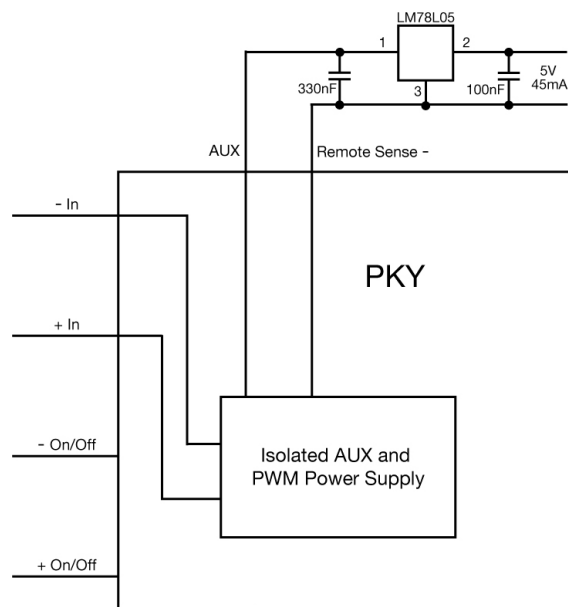

Thermal Consideration

PKY 4000 PI series
DC/DC converters, Input 36-75 V, Output up to 25 A/700 W

EN/LZT 146 380 R2A Oct 2008

© Ericsson Power Modules AB

General

The products are designed to operate in different thermal environments and sufficient cooling must be provided to ensure reliable operation.

Cooling of the PKY series power modules is achieved mainly by conduction from the baseplate to a heatsink ("cold wall").

The PKY series power modules can also operate without a heatsink but sufficient airflow must be provided. The Output Current Derating graph found in the Output section for each model provides the available output current vs. ambient air temperature and air velocity at $V_{in} = 53 V$.

The product is tested on a 254 x 254 mm, 35 μm (1 oz), 8-layer test board mounted vertically in a wind tunnel with a cross-section of 608 x 203 mm.

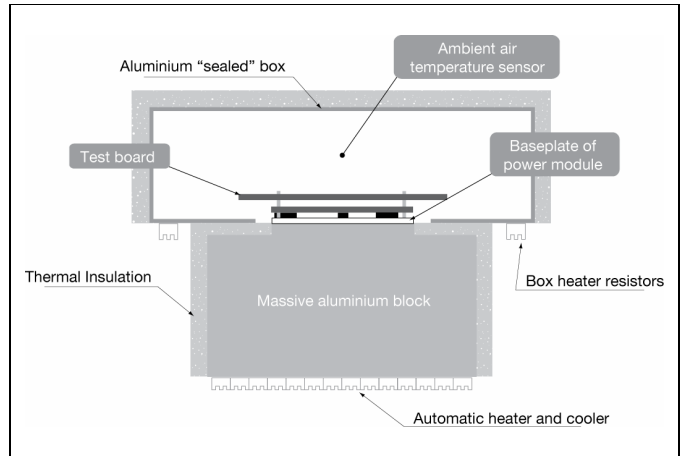

Proper cooling of the product can be verified by measuring the temperature at positions P1, P2, P3, P4 and P5. The temperature at these positions should not exceed the max values provided in the table below. The number of points may vary with different thermal design and topology.

See Design Note 019 for further information.

Position	Description	Temp. limit
P1	Baseplate	100° C
P2	M1	120° C
P3	PCB	125° C
P4	D15	120° C
P5	T16	120° C

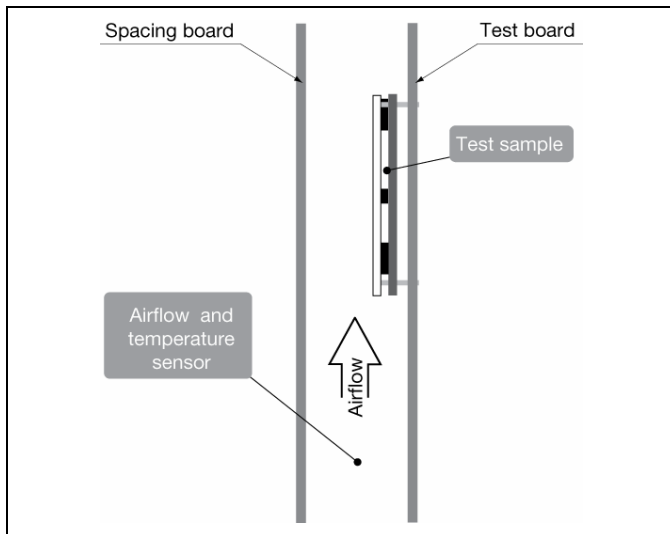

For products with base plate used in a sealed box/cold wall application, cooling is achieved mainly by conduction through the cold wall. The Output Current Derating graphs are found in the Output section for each model. The product is tested in a sealed box test set up with ambient temperatures 85°C. See Design Note 028 for further details.

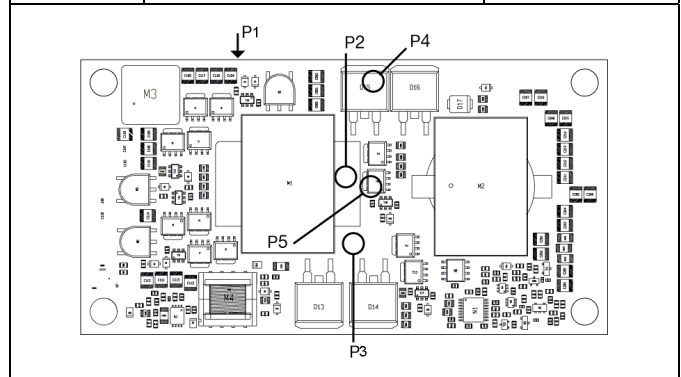

Definition of reference temperature T_{P1}

The reference temperature is used to monitor the temperature limits of the product. Temperatures above maximum T_{P1} , measured at the reference point P1, are not allowed and may cause degradation or permanent damage to the product. T_{P1} is also used to define the temperature range for normal operating conditions. T_{P1} is defined by the design and used to guarantee safety margins, proper operation and high reliability of the product.

PKY 4000 PI series

DC/DC converters, Input 36-75 V, Output up to 25 A/700 W

EN/LZT 146 380 R2A Oct 2008

© Ericsson Power Modules AB

Ambient Temperature Calculation

For products with base plate the maximum allowed ambient temperature can be calculated by using the thermal resistance.

1. The power loss is calculated by using the formula $((1/\eta) - 1) \times \text{output power} = \text{power losses (Pd)}$.
 η = efficiency of product. E.g. 93.3% = 0.933

2. Find the thermal resistance (Rth) in the Thermal Resistance graph found in the Output section for each model. **Note that the thermal resistance can be significantly reduced if a heat sink is mounted on the top of the base plate.**

Calculate the temperature increase (ΔT).

$$\Delta T = R_{th} \times P_d$$

3. Max allowed ambient temperature is:

$$\text{Max } T_{P1} - \Delta T.$$

E.g. PKY 4716 PI at 2m/s:

$$1. ((\frac{1}{0.933}) - 1) \times 700 \text{ W} = 50.27 \text{ W}$$

$$2. 50.27 \text{ W} \times 1.1^\circ\text{C/W} = 55.3^\circ\text{C}$$

$$3. 100^\circ\text{C} - 55.3^\circ\text{C} = \text{max ambient temperature is } 44.7^\circ\text{C}$$

The actual temperature will be dependent on several factors such as the PCB size, number of layers and direction of airflow.

The above calculations of the maximum ambient temperature are based on the thermal resistance of the PKY module without a heatsink.

Connections

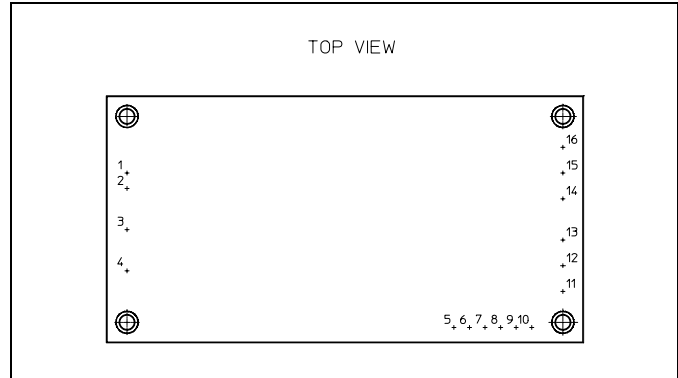

Pin	Designation	Function
1	+On/Off	Remote on/off "plus" input
2	-On/Off	Remote on/off "minus" input
3	+In	Positive input
4	-In	Negative input
5	AUX	Auxiliary power supply output
6	PWR Good	Power Good output
7	Optional	N/A
8	Vadj	Output Voltage Adjust
9	+Sense	Positive remote sense
10	-Sense	Negative remote sense
11	-Vout	Negative output voltage
12	-Vout	Negative output voltage
13	-Vout	Negative output voltage
14	+Vout	Positive output voltage
15	+Vout	Positive output voltage
16	+Vout	Positive output voltage

PKY 4000 PI series DC/DC converters, Input 36-75 V, Output up to 25 A/700 W	EN/LZT 146 380 R2A Oct 2008
	© Ericsson Power Modules AB

Mechanical Information

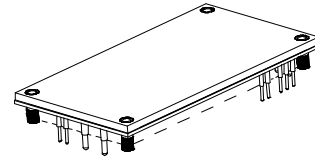
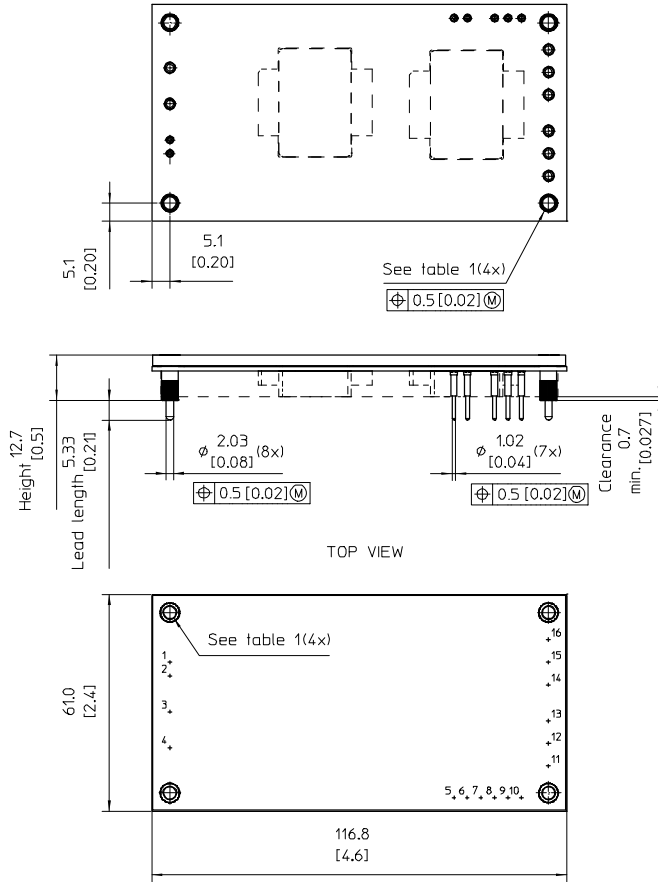

Table 1

Product	Insert	Outer ϕ
Standard	M3x0.5 Threaded	4.62 [0.182]
M-Option	ϕ 3.50 [0.138] TH	4.62 [0.182]

Notes

Case: Aluminium base plate
For screw attachment, apply mounting torque of max 0.44 Nm [3.9 Lbf-in]

Pins:
1,2,5-10 Material: Brass
3,4,11-16 Material: Cu-alloy
Plating:
0.1 μ m Gold over 2 μ m Nickel

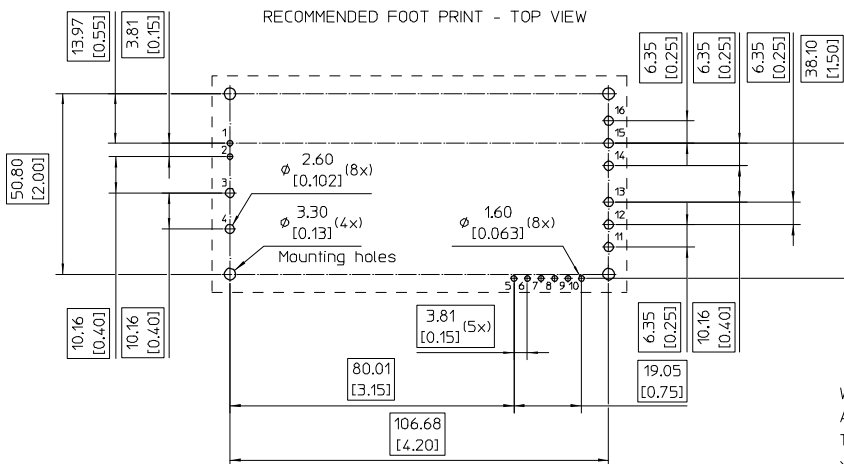

Weight: Typical 165 g
All dimensions in mm [inch].
Tolerances unless specified
x.x mm \pm 0.50 [0.02], x.xx mm \pm 0.25 [0.01]
 (not applied on footprint or typical values)

PKY 4000 PI series DC/DC converters, Input 36-75 V, Output up to 25 A/700 W	EN/LZT 146 380 R2A Oct 2008
	© Ericsson Power Modules AB

Soldering Information – Through Hole Mounting

The product is intended for manual or wave soldering. When wave soldering is used, the temperature on the pins is specified to maximum 270°C for maximum 10 seconds.

A maximum preheat rate of 4°C/s and a temperature of max +150°C is suggested. When soldering by hand, care should be taken to avoid direct contact between the hot soldering iron tip and the pins for more than a few seconds in order to prevent overheating.

A no-clean flux is recommended to avoid entrapment of cleaning fluids in cavities inside the product or between the product and the host board. The cleaning residues may affect long time reliability and isolation voltage.

Delivery Package Information

The products are delivered in antistatic trays.

Tray Specifications	
Material	Antistatic PE Foam
Surface resistance	$10^5 < \text{Ohm/square} < 10^{12}$
Bakability	The trays are not bakable
Tray capacity	5 products/tray
Tray thickness	26.0 mm [1.024 inch]
Box capacity	5 products (1 full tray/box)
Tray weight	55 g empty, 880 g full tray

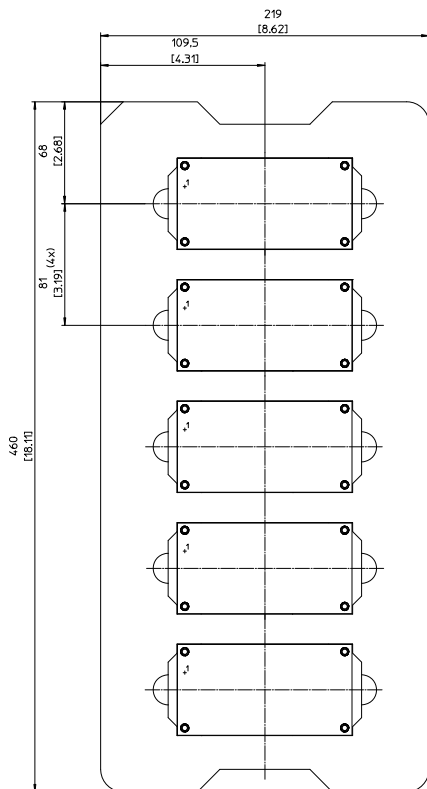

PKY 4000 PI series DC/DC converters, Input 36-75 V, Output up to 25 A/700 W	EN/LZT 146 380 R2A Oct 2008
	© Ericsson Power Modules AB

Product Qualification Specification

Characteristics			
External visual inspection	IPC-A-610		
Change of temperature (Temperature cycling)	IEC 60068-2-14 Na	Temperature range Number of cycles Dwell/transfer time	-40 to +100°C 1000 15 min/0-1 min
Cold (in operation)	IEC 60068-2-1 Ad	Temperature T _A Duration	-45°C 72 h
Damp heat	IEC 60068-2-67 Cy	Temperature Humidity Duration	+85°C 85 % RH 1000 hours
Dry heat	IEC 60068-2-2 Bd	Temperature Duration	+125°C 1000 h
Electrostatic discharge susceptibility	IEC 61340-3-1, JESD 22-A114 IEC 61340-3-2, JESD 22-A115	Human body model (HBM) Machine Model (MM)	Class 2, 2000 V Class 3, 200 V
Immersion in cleaning solvents	IEC 60068-2-45 XA Method 2	Water Glycol ether Isopropyl alcohol	+55°C +35°C +35°C
Mechanical shock	IEC 60068-2-27 Ea	Peak acceleration Duration	100 g 6 ms
Operational life test	MIL-STD-202G method 108A	Duration	1000 h
Resistance to soldering heat	IEC 60068-2-20 Tb Method 1A	Solder temperature Duration	270°C 10-13 s
Robustness of terminations	IEC 60068-2-21 Test Ua1	Through hole mount product	All leads
Solderability	IEC 60068-2-20 test Ta ²	Preconditioning Temperature, SnPb Eutectic Temperature, Pb-free	Steam ageing 235°C 245°C
Vibration, broad band random	IEC 60068-2-64 Fh, method 1	Frequency Spectral density Duration	10 to 500 Hz 0.07 g ² /Hz 10 min in each perpendicular direction