

### GENERAL DESCRIPTION



The ICS8308I is a low-skew, 1-to-8 Fanout Buffer and a member of the HiPerClockS™ family of High Performance Clock Solutions from IDT. The ICS8308I has two selectable clock inputs. The CLK, nCLK pair can accept most differential input levels.

The LVCMOS\_CLK can accept LVCMOS or LVTTTL input levels. The low impedance LVCMOS/LVTTTL outputs are designed to drive 50Ω series or parallel terminated transmission lines. The effective fanout can be increased from 8 to 16 by utilizing the ability of the outputs to drive two series terminated transmission lines.

The ICS8308I is characterized for 3.3V core/3.3V output, 3.3V core/2.5V output or 2.5V core/2.5V output operation. Guaranteed output and part-part skew characteristics make the 8308I ideal for those clock distribution applications requiring well defined performance and repeatability.

### FEATURES

- Eight LVCMOS/LVTTTL outputs, (7Ω typical output impedance)
- Selectable LVCMOS\_CLK or differential CLK, nCLK inputs
- CLK, nCLK pair can accept the following differential input levels: LVPECL, LVDS, LVHSTL, SSTL, HCSL
- Maximum Output Frequency: 350MHz
- Output Skew: (3.3V± 5%): 100ps (maximum)
- Part to Part Skew: (3.3V± 5%): 1ns (maximum)
- Supply Voltage Modes:  
(Core/Output)  
3.3V/3.3V  
3.3V/2.5V  
2.5V/2.5V
- -40°C to 85°C ambient operating temperature
- Available in both standard (RoHS 5) and lead-free (RoHS 6) packages

### BLOCK DIAGRAM

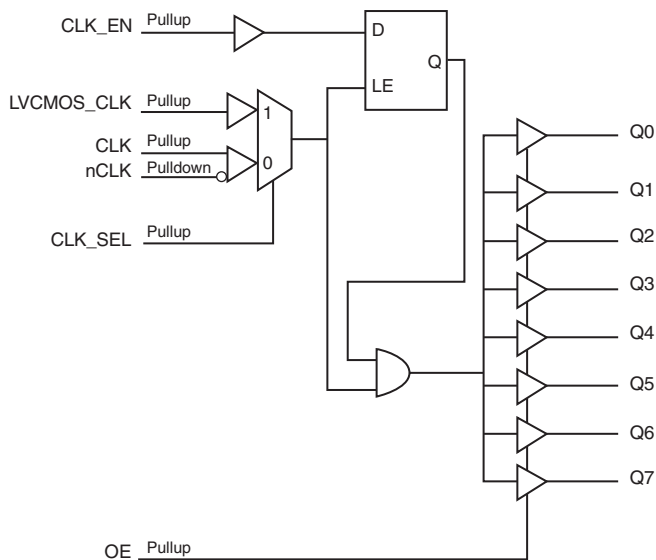

### PIN ASSIGNMENT

Q0	1	24	V <sub>DD0</sub>
GND	2	23	Q2
CLK_SEL	3	22	GND
LVCMOS_CLK	4	21	Q3
CLK	5	20	V <sub>DD0</sub>
nCLK	6	19	Q4
CLK_EN	7	18	GND
OE	8	17	Q5
V <sub>DD</sub>	9	16	V <sub>DD0</sub>
GND	10	15	Q6
Q1	11	14	GND
V <sub>DD0</sub>	12	13	Q7

**ICS8308I**  
**24-Lead, 173-MIL TSSOP**  
 4.4mm x 7.8mm x 0.925mm body package  
**G Package**  
 Top View

TABLE 1. PIN DESCRIPTIONS

Number	Name	Type		Description
1, 11, 13, 15, 17, 19, 21, 23	Q0, Q1, Q7, Q6, Q5, Q4, Q3, Q2	Output		Clock outputs. LVCMOS / LVTTTL interface levels.
2, 10, 14, 18, 22	GND	Power		Power supply ground.
3	CLK_SEL	Input	Pullup	Clock select input. Selects LVCMOS clock input when HIGH. Selects CLK, nCLK inputs when LOW. See Table 3A. LVCMOS / LVTTTL interface levels.
4	LVCMOS_CLK	Input	Pullup	Clock input. LVCMOS / LVTTTL interface levels.
5	CLK	Input	Pullup	Non-inverting differential clock input.
6	nCLK	Input	Pulldown	Inverting differential clock input.
7	CLK_EN	Input	Pullup	Clock enable. LVCMOS / LVTTTL interface levels.
8	OE	Input	Pullup	Output enable. LVCMOS / LVTTTL interface levels. See Table 3B.
9	V <sub>DD</sub>	Power		Core supply pin.
12, 16, 20, 24	V <sub>DDO</sub>	Power		Output supply pins.

NOTE: *Pullup* and *Pulldown* refer to internal input resistors. See Table 2, Pin Characteristics, for typical values.

TABLE 2. PIN CHARACTERISTICS

Symbol	Parameter	Test Conditions	Minimum	Typical	Maximum	Units
C <sub>IN</sub>	Input Capacitance			4		pF
C <sub>PD</sub>	Power Dissipation Capacitance (per output)			12		pF
R <sub>PULLUP</sub>	Input Pullup Resistor			51		kΩ
R <sub>PULLDOWN</sub>	Input Pulldown Resistor			51		kΩ
R <sub>OUT</sub>	Output Impedance		5	7	12	Ω

TABLE 3A. CLOCK SELECT FUNCTION TABLE

Control Input	Clock Input
CLK_SEL	
0	CLK, nCLK is selected
1	LVCMOS_CLK is selected

TABLE 3B. OE SELECT FUNCTION TABLE

Control Input	Output Operation
OE	
0	Outputs Q0:Q7 are in Hi-Z (disabled)
1	Outputs Q0:Q7 are active (enabled)

TABLE 3C. CLOCK INPUT FUNCTION TABLE

Inputs				Outputs	Input to Output Mode	Polarity
CLK_SEL	LVCMOS_CLK	CLK	nCLK	Q0:Q7		
0	—	0	1	LOW	Differential to Single Ended	Non Inverting
0	—	1	0	HIGH	Differential to Single Ended	Non Inverting
0	—	0	Biased; NOTE 1	LOW	Single Ended to Single Ended	Non Inverting
0	—	1	Biased; NOTE 1	HIGH	Single Ended to Single Ended	Non Inverting
0	—	Biased; NOTE 1	0	HIGH	Single Ended to Single Ended	Inverting
0	—	Biased; NOTE 1	1	LOW	Single Ended to Single Ended	Inverting
1	0	—	—	LOW	Single Ended to Single Ended	Non Inverting
1	1	—	—	HIGH	Single Ended to Single Ended	Non Inverting

NOTE 1: Please refer to the Application Information section, "Wiring the Differential Input to Accept Single Ended Levels".

**ABSOLUTE MAXIMUM RATINGS**

Supply Voltage, $V_{DD}$	4.6V
Inputs, $V_I$	-0.5V to $V_{DD} + 0.5$ V
Outputs, $V_O$	-0.5V to $V_{DDO} + 0.5$ V
Package Thermal Impedance, $\theta_{JA}$	70°C/W (0 lfpm)
Storage Temperature, $T_{STG}$	-65°C to 150°C

NOTE: Stresses beyond those listed under Absolute Maximum Ratings may cause permanent damage to the device. These ratings are stress specifications only. Functional operation of product at these conditions or any conditions beyond those listed in the *DC Characteristics* or *AC Characteristics* is not implied. Exposure to absolute maximum rating conditions for extended periods may affect product reliability.

**TABLE 4A. POWER SUPPLY DC CHARACTERISTICS,  $V_{DD} = V_{DDO} = 3.3V \pm 5\%$ ,  $T_A = -40^\circ$  TO  $85^\circ$** 

Symbol	Parameter	Test Conditions	Minimum	Typical	Maximum	Units
$V_{DD}$	Core Supply Voltage		3.135	3.3	3.465	V
$V_{DDO}$	Output Supply Voltage		3.135	3.3	3.465	V
$I_{DD}$	Power Supply Current				46	mA
$I_{DDO}$	Output Supply Current				11	mA

**TABLE 4B. POWER SUPPLY DC CHARACTERISTICS,  $V_{DD} = 3.3V \pm 5\%$ ,  $V_{DDO} = 2.5V \pm 5\%$ ,  $T_A = -40^\circ$  TO  $85^\circ$** 

Symbol	Parameter	Test Conditions	Minimum	Typical	Maximum	Units
$V_{DD}$	Core Supply Voltage		3.135	3.3	3.465	V
$V_{DDO}$	Output Supply Voltage		2.375	2.5	2.625	V
$I_{DD}$	Power Supply Current				46	mA
$I_{DDO}$	Output Supply Current				10	mA

**TABLE 4C. POWER SUPPLY DC CHARACTERISTICS,  $V_{DD}, V_{DDO} = 2.5V \pm 5\%$ ,  $T_A = -40^\circ$  TO  $85^\circ$** 

Symbol	Parameter	Test Conditions	Minimum	Typical	Maximum	Units
$V_{DD}$	Core Supply Voltage		2.375	2.5	2.625	V
$V_{DDO}$	Output Supply Voltage		2.375	2.5	2.625	V
$I_{DD}$	Power Supply Current				43	mA
$I_{DDO}$	Output Supply Current				10	mA

**TABLE 4D. DC CHARACTERISTICS,  $V_{DD} = V_{DDO} = 3.3V \pm 5\%$ ,  $T_A = -40^\circ$  TO  $85^\circ$** 

Symbol	Parameter	Test Conditions	Minimum	Typical	Maximum	Units
$V_{IH}$	Input High Voltage	LVCMOS	2		$V_{DD} + 0.3$	V
$V_{IL}$	Input Low Voltage	LVCMOS_CLK	-0.3		1.3	V
		CLK_EN, OE			0.8	V
$I_{IN}$	Input Current	$V_{IN} = V_{DD}$ or $V_{IN} = GND$			300	$\mu A$
$V_{OH}$	Output High Voltage; NOTE 1	$I_{OH} = -24mA$	2.4			V
$V_{OL}$	Output Low Voltage; NOTE 1	$I_{OL} = 24mA$			0.55	V
		$I_{OL} = 12mA$			0.30	V
$V_{PP}$	Peak-to-Peak Input Voltage	CLK, nCLK	0.15		1.3	V
$V_{CMR}$	Input Common Mode Voltage; NOTE 2, 3	CLK, nCLK	GND + 0.5		$V_{DD} - 0.85$	V

NOTE 1: Outputs capable of driving 50 $\Omega$  transmission lines terminated with 50 $\Omega$  to  $V_{DDO}/2$ .

See Parameter Measurement section, "3.3V Output Load AC Test Circuit".

NOTE 2: For single ended applications, the maximum input voltage for CLK, nCLK is  $V_{DD} + 0.3V$ .

NOTE 3: Common mode voltage is defined as  $V_{IH}$ .

**TABLE 4E. DC CHARACTERISTICS,  $V_{DD} = 3.3V \pm 5\%$ ,  $V_{DDO} = 2.5V \pm 5\%$ ,  $T_A = -40^\circ$  TO  $85^\circ$** 

Symbol	Parameter	Test Conditions	Minimum	Typical	Maximum	Units
$V_{IH}$	Input High Voltage	LVCMOS	2		$V_{DD} + 0.3$	V
$V_{IL}$	Input Low Voltage	LVCMOS_CLK	-0.3		1.3	V
		CLK_EN, OE			0.8	V
$I_{IN}$	Input Current	$V_{IN} = V_{DD}$ or $V_{IN} = GND$			300	$\mu A$
$V_{OH}$	Output High Voltage; NOTE 1	$I_{OH} = -15mA$	1.8			V
$V_{OL}$	Output Low Voltage; NOTE 1	$I_{OL} = 15mA$			0.6	V
$V_{PP}$	Peak-to-Peak Input Voltage	CLK, nCLK	0.15		1.3	V
$V_{CMR}$	Input Common Mode Voltage; NOTE 2, 3	CLK, nCLK	GND + 0.5		$V_{DD} - 0.85$	V

NOTE 1: Outputs capable of driving 50 $\Omega$  transmission lines terminated with 50 $\Omega$  to  $V_{DDO}/2$ .

See Parameter Measurement section, "3.3V Output Load AC Test Circuit".

NOTE 2: For single ended applications, the maximum input voltage for CLK, nCLK is  $V_{DD} + 0.3V$ .

NOTE 3: Common mode voltage is defined as  $V_{IH}$ .

**TABLE 4F. DC CHARACTERISTICS,  $V_{DD}, V_{DDO} = 2.5V \pm 5\%$ ,  $T_A = -40^\circ$  TO  $85^\circ$** 

Symbol	Parameter	Test Conditions	Minimum	Typical	Maximum	Units
$V_{IH}$	Input High Voltage	LVCMOS	1.7		$V_{DD} + 0.3$	V
$V_{IL}$	Input Low Voltage	LVCMOS_CLK	-0.3		0.7	V
		CLK_EN, OE			0.7	V
$I_{IN}$	Input Current	$V_{IN} = V_{DD}$ or $V_{IN} = GND$			300	$\mu A$
$V_{OH}$	Output High Voltage; NOTE 1	$I_{OH} = -15mA$	1.8			V
$V_{OL}$	Output Low Voltage; NOTE 1	$I_{OL} = 15mA$			0.6	V
$V_{PP}$	Peak-to-Peak Input Voltage	CLK, nCLK	0.15		1.3	V
$V_{CMR}$	Input Common Mode Voltage; NOTE 2, 3	CLK, nCLK	GND + 0.5		$V_{DD} - 0.85$	V

NOTE 1: Outputs capable of driving 50 $\Omega$  transmission lines terminated with 50 $\Omega$  to  $V_{DDO}/2$ .

See Parameter Measurement section, "3.3V Output Load AC Test Circuit".

NOTE 2: For single ended applications, the maximum input voltage for CLK, nCLK is  $V_{DD} + 0.3V$ .

NOTE 3: Common mode voltage is defined as  $V_{IH}$ .

**TABLE 5A. AC CHARACTERISTICS,  $V_{DD} = V_{DDO} = 3.3V \pm 5\%$ ,  $T_A = -40^\circ$  TO  $85^\circ$** 

Symbol	Parameter	Test Conditions	Minimum	Typical	Maximum	Units
$f_{MAX}$	Output Frequency				350	MHz
$t_{PD}$	Propagation Delay;	CLK, nCLK; NOTE 1	$f \leq 350MHz$	2	4	ns
		LVCMOS_CLK; NOTE 2	$f \leq 350MHz$	2	4	ns
$tsk(o)$	Output Skew; NOTE 3, 7	Measured on rising edge @ $V_{DDO}/2$			100	ps
$tsk(pp)$	Part-to-Part Skew; NOTE 4, 7	Measured on rising edge @ $V_{DDO}/2$			1	ns
$t_R / t_F$	Output Rise/Fall Time	0.8V to 2V	0.2		1	ns
odc	Output Duty Cycle	$f \leq 150MHz$ , Ref = CLK, nCLK	45		55	%
$t_{PZL}, t_{PZH}$	Output Enable Time; NOTE 5				5	ns
$t_{PLZ}, t_{PHZ}$	Output Disable Time; NOTE 5				5	ns
$t_S$	Clock Enable Setup Time; NOTE 6	CLK_EN to CLK, nCLK		1		ns
		CLK_EN to LVCMOS_CLK		0		ns
$t_H$	Clock Enable Hold Time; NOTE 6	CLK, nCLK to CLK_EN		0		ns
		LVCMOS_CLK to CLK_EN		1		ns

NOTE: Electrical parameters are guaranteed over the specified ambient operating temperature range, which is established when the device is mounted in a test socket with maintained transverse airflow greater than 500 lfm. The device will meet specifications after thermal equilibrium has been reached under these conditions.

NOTE 1: Measured from the differential input crossing point to  $V_{DDO}/2$  of the output.

NOTE 2: Measured from  $V_{DD}/2$  of the input to  $V_{DDO}/2$  of the output.

NOTE 3: Defined as skew between outputs at the same supply voltage and with equal load conditions.

Measured at  $V_{DDO}/2$ .

NOTE 4: Defined as skew between outputs on different devices operating at the same supply voltages and with equal load conditions. Using the same type of inputs on each device, the outputs are measured at  $V_{DDO}/2$ .

NOTE 5: These parameters are guaranteed by characterization. Not tested in production.

NOTE 6: Setup and Hold times are relative to the rising edge of the input clock.

NOTE 7: This parameter is defined in accordance with JEDEC Standard 65.

**TABLE 5B. AC CHARACTERISTICS,  $V_{DD} = 3.3V \pm 5\%$ ,  $V_{DDO} = 2.5V \pm 5\%$ ,  $T_A = -40^\circ$  TO  $85^\circ$** 

Symbol	Parameter	Test Conditions	Minimum	Typical	Maximum	Units
$f_{MAX}$	Output Frequency				350	MHz
$t_{PD}$	Propagation Delay;	CLK, nCLK; NOTE 1	$f \leq 350\text{MHz}$	2	4	ns
		LVCMOS_CLK; NOTE 2	$f \leq 350\text{MHz}$	2	4	ns
$t_{sk(o)}$	Output Skew; NOTE 3, 7	Measured on rising edge @ $V_{DDO}/2$			100	ps
$t_{sk(pp)}$	Part-to-Part Skew; NOTE 4, 7	Measured on rising edge @ $V_{DDO}/2$			1	ns
$t_R / t_F$	Output Rise/Fall Time	0.6V to 1.8V	0.2		1.0	ns
odc	Output Duty Cycle	$f \leq 150\text{MHz}$ , Ref = CLK, nCLK	45		55	%
$t_{PZL}, t_{PZH}$	Output Enable Time; NOTE 5				5	ns
$t_{PLZ}, t_{PHZ}$	Output Disable Time; NOTE 5				5	ns
$t_S$	Clock Enable Setup Time; NOTE 6	CLK_EN to CLK, nCLK	1			ns
		CLK_EN to LVCMOS_CLK	0			ns
$t_H$	Clock Enable Hold Time; NOTE 6	CLK, nCLK to CLK_EN	0			ns
		LVCMOS_CLK to CLK_EN	1			ns

NOTE: Electrical parameters are guaranteed over the specified ambient operating temperature range, which is established when the device is mounted in a test socket with maintained transverse airflow greater than 500 lfm. The device will meet specifications after thermal equilibrium has been reached under these conditions.

NOTE 1: Measured from the differential input crossing point to  $V_{DDO}/2$  of the output.

NOTE 2: Measured from  $V_{DD}/2$  of the input to  $V_{DDO}/2$  of the output.

NOTE 3: Defined as skew between outputs at the same supply voltage and with equal load conditions. Measured at  $V_{DDO}/2$ .

NOTE 4: Defined as skew between outputs on different devices operating at the same supply voltages and with equal load conditions. Using the same type of inputs on each device, the outputs are measured at  $V_{DDO}/2$ .

NOTE 5: These parameters are guaranteed by characterization. Not tested in production.

NOTE 6: Setup and Hold times are relative to the rising edge of the input clock.

NOTE 7: This parameter is defined in accordance with JEDEC Standard 65.

**TABLE 5C. AC CHARACTERISTICS,  $V_{DD} = V_{DDO} = 2.5V \pm 5\%$ ,  $T_A = -40^\circ$  TO  $85^\circ$** 

Symbol	Parameter	Test Conditions	Minimum	Typical	Maximum	Units
$f_{MAX}$	Output Frequency				350	MHz
$t_{PD}$	Propagation Delay;	CLK, nCLK; NOTE 1	$f \leq 350\text{MHz}$	1.5	4.2	ns
		LVCMOS_CLK; NOTE 2	$f \leq 350\text{MHz}$	1.7	4.4	ns
$t_{sk(o)}$	Output Skew; NOTE 3, 7	Measured on rising edge @ $V_{DDO}/2$			160	ps
$t_{sk(pp)}$	Part-to-Part Skew; NOTE 4, 7	Measured on rising edge @ $V_{DDO}/2$			2	ns
$t_R / t_F$	Output Rise/Fall Time	0.6V to 1.8V	0.2		1.0	ns
odc	Output Duty Cycle	$f \leq 150\text{MHz}$ , Ref = CLK, nCLK	40		60	%
$t_{PZL}, t_{PZH}$	Output Enable Time; NOTE 5				5	ns
$t_{PLZ}, t_{PHZ}$	Output Disable Time; NOTE 5				5	ns
$t_S$	Clock Enable Setup Time; NOTE 6	CLK_EN to CLK, nCLK	1			ns
		CLK_EN to LVCMOS_CLK	0			ns
$t_H$	Clock Enable Hold Time; NOTE 6	CLK, nCLK to CLK_EN	0			ns
		LVCMOS_CLK to CLK_EN	1			ns

NOTE: Electrical parameters are guaranteed over the specified ambient operating temperature range, which is established when the device is mounted in a test socket with maintained transverse airflow greater than 500 lfm. The device will meet specifications after thermal equilibrium has been reached under these conditions.

NOTE 1: Measured from the differential input crossing point to  $V_{DDO}/2$  of the output.

NOTE 2: Measured from  $V_{DD}/2$  of the input to  $V_{DDO}/2$  of the output.

NOTE 3: Defined as skew between outputs at the same supply voltage and with equal load conditions. Measured at  $V_{DDO}/2$ .

NOTE 4: Defined as skew between outputs on different devices operating at the same supply voltages and with equal load conditions. Using the same type of inputs on each device, the outputs are measured at  $V_{DDO}/2$ .

NOTE 5: These parameters are guaranteed by characterization. Not tested in production.

NOTE 6: Setup and Hold times are relative to the rising edge of the input clock.

NOTE 7: This parameter is defined in accordance with JEDEC Standard 65.

## PARAMETER MEASUREMENT INFORMATION

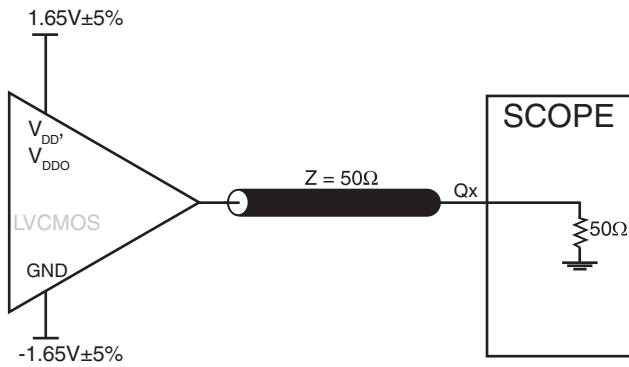

3.3V CORE/3.3V OUTPUT LOAD AC TEST CIRCUIT

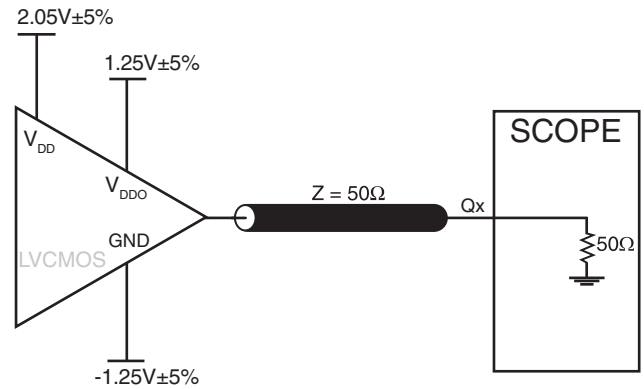

3.3V CORE/2.5V OUTPUT LOAD AC TEST CIRCUIT

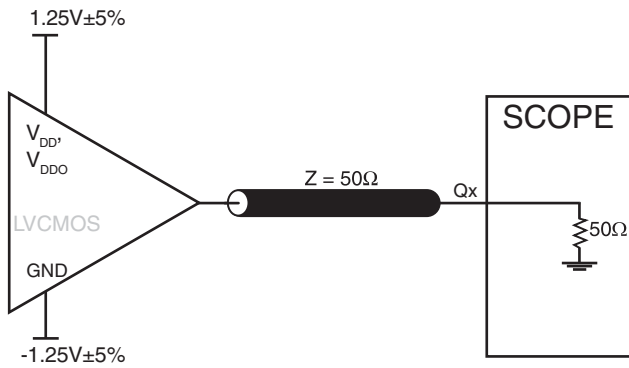

2.5V CORE/2.5V OUTPUT LOAD AC TEST CIRCUIT

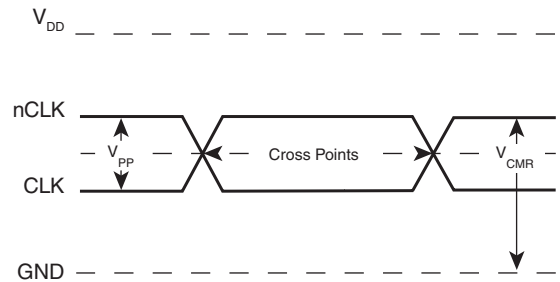

DIFFERENTIAL INPUT LEVEL

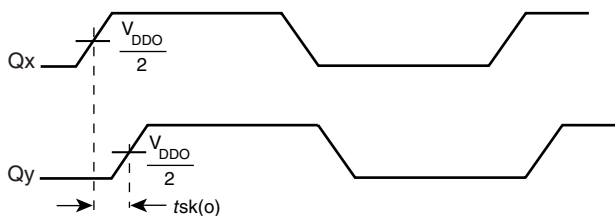

OUTPUT SKEW

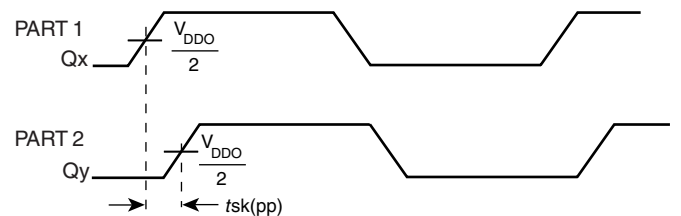

PART-TO-PART SKEW



## PARAMETER MEASUREMENT INFORMATION, CONTINUED

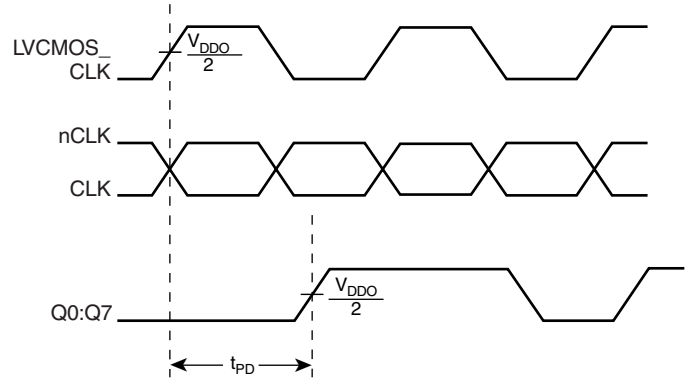
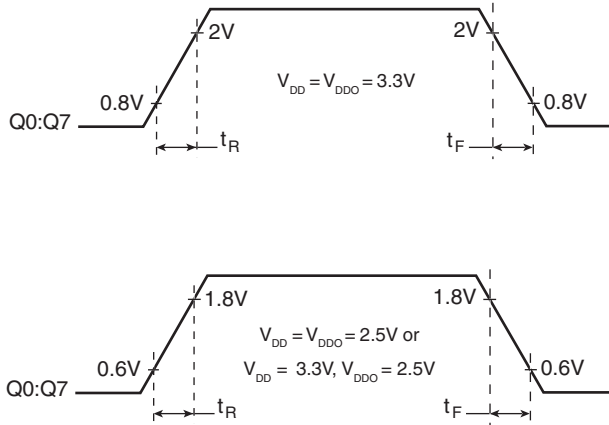

### OUTPUT RISE/FALL TIME

### PROPAGATION DELAY

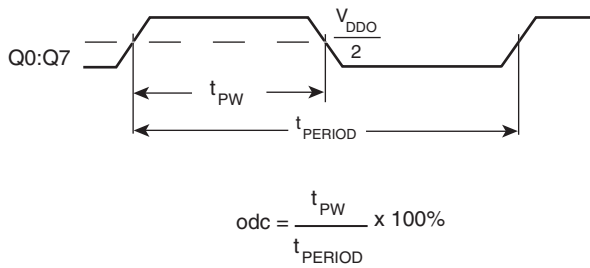

### OUTPUT DUTY CYCLE/PULSE WIDTH/PERIOD

## APPLICATION INFORMATION

### WIRING THE DIFFERENTIAL INPUT TO ACCEPT SINGLE ENDED LEVELS

Figure 1 shows how the differential input can be wired to accept single ended levels. The reference voltage  $V_{REF} = V_{DD}/2$  is generated by the bias resistors R1, R2 and C1. This bias circuit should be located as close as possible to the input pin. The ratio

of R1 and R2 might need to be adjusted to position the  $V_{REF}$  in the center of the input voltage swing. For example, if the input clock swing is only 2.5V and  $V_{DD} = 3.3V$ ,  $V_{REF}$  should be 1.25V and  $R2/R1 = 0.609$ .

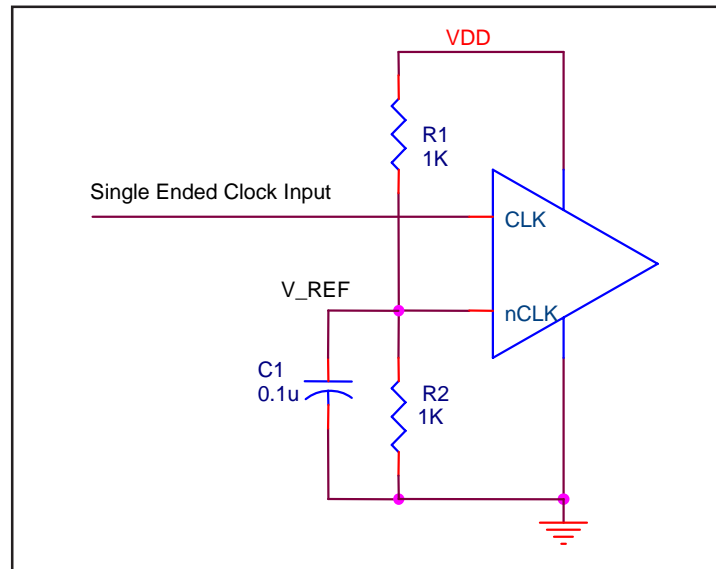

FIGURE 1. SINGLE ENDED SIGNAL DRIVING DIFFERENTIAL INPUT

### RECOMMENDATIONS FOR UNUSED INPUT AND OUTPUT PINS

#### INPUTS:

##### CLK INPUT

For applications not requiring the use of the test clock, it can be left floating. Though not required, but for additional protection, a 1k $\Omega$  resistor can be tied from the CLK input to ground.

##### CLK/nCLK INPUTS

For applications not requiring the use of the differential input, both CLK and nCLK can be left floating. Though not required, but for additional protection, a 1k $\Omega$  resistor can be tied from CLK to ground.

##### LVCMOS CONTROL PINS

All control pins have internal pull-ups or pull-downs; additional resistance is not required but can be added for additional protection. A 1k $\Omega$  resistor can be used.

#### OUTPUTS:

##### LVCMOS OUTPUTS

All unused LVCMOS output can be left floating. There should be no trace attached.

### DIFFERENTIAL CLOCK INPUT INTERFACE

The CLK /nCLK accepts LVDS, LVPECL, LVHSTL, SSTL, HCSTL and other differential signals. Both  $V_{SWING}$  and  $V_{OH}$  must meet the  $V_{PP}$  and  $V_{CMR}$  input requirements. Figures 2A to 2E show interface examples for the HiPerClockS CLK/nCLK input driven by the most common driver types. The input interfaces suggested here are

examples only. Please consult with the vendor of the driver component to confirm the driver termination requirements. For example in *Figure 2A*, the input termination applies for ICS HiPerClockS LVHSTL drivers. If you are using an LVHSTL driver from another vendor, use their termination recommendation.

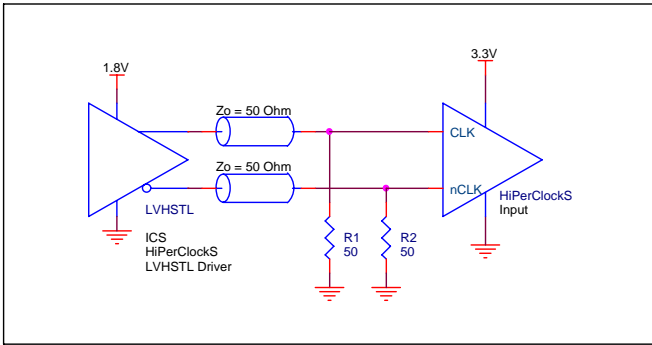

**FIGURE 2A. HiPerClockS CLK/nCLK INPUT DRIVEN BY ICS HiPerClockS LVHSTL DRIVER**

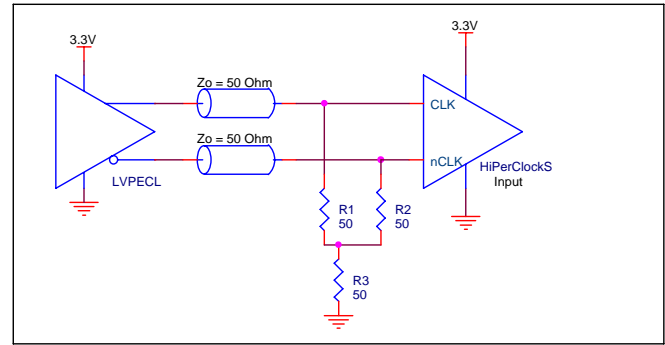

**FIGURE 2B. HiPerClockS CLK/nCLK INPUT DRIVEN BY 3.3V LVPECL DRIVER**

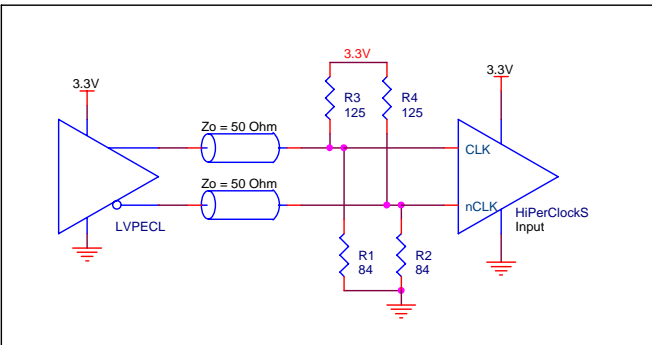

**FIGURE 2C. HiPerClockS CLK/nCLK INPUT DRIVEN BY 3.3V LVPECL DRIVER**

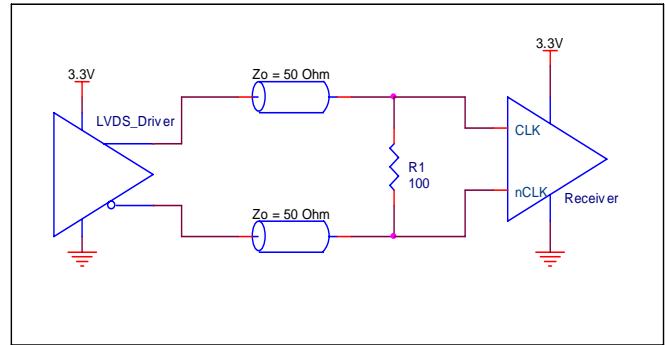

**FIGURE 2D. HiPerClockS CLK/nCLK INPUT DRIVEN BY 3.3V LVDS DRIVER**

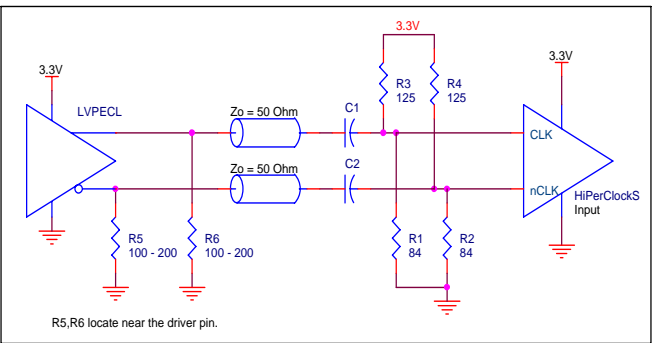
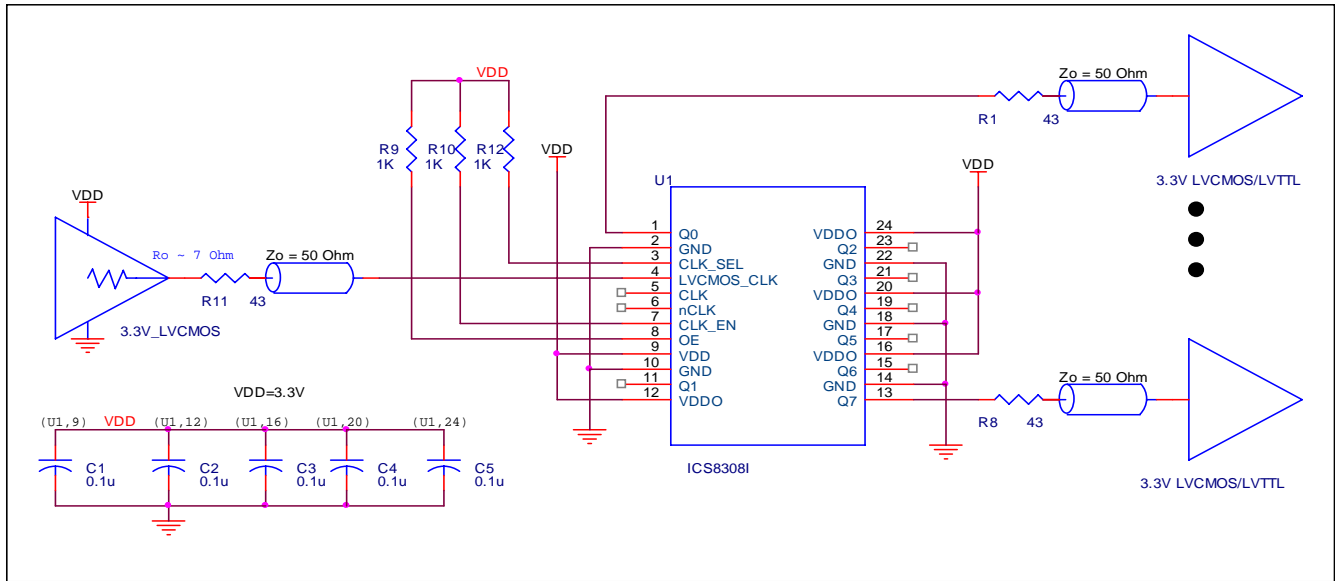

**FIGURE 2E. HiPerClockS CLK/nCLK INPUT DRIVEN BY 3.3V LVPECL DRIVER WITH AC COUPLE**

**SCHEMATIC EXAMPLE**

Figure 3 shows a schematic example of the ICS8308I. In this example, the LVCMOS\_CLK input is selected. The decoupling

capacitors should be physically located near the power pin.



**FIGURE 3. ICS8308I LVPECL BUFFER SCHEMATIC EXAMPLE**

**RELIABILITY INFORMATION**

**TABLE 6.  $\theta_{JA}$  vs. AIR FLOW TABLE FOR 24 LEAD TSSOP**

$\theta_{JA}$ by Velocity (Linear Feet per Minute)			
	0	200	500
Multi-Layer PCB, JEDEC Standard Test Boards	70°C/W	63°C/W	60°C/W

**TRANSISTOR COUNT**

The transistor count for ICS8308I is: 1040

## PACKAGE OUTLINE - G SUFFIX FOR 24 LEAD TSSOP

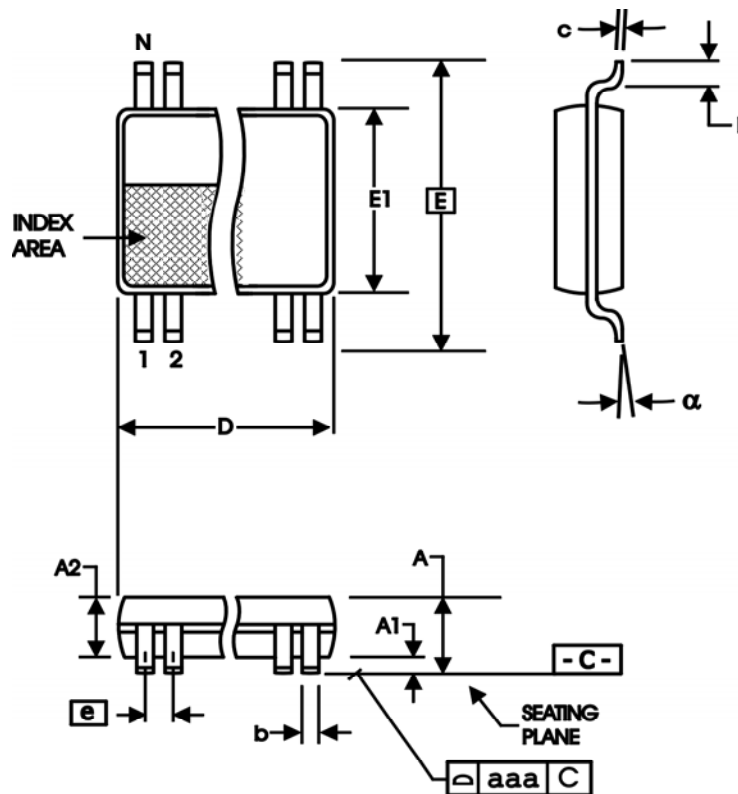

TABLE 7. PACKAGE DIMENSIONS

SYMBOL	Millimeters	
	Minimum	Maximum
N	24	
A	--	1.20
A1	0.05	0.15
A2	0.80	1.05
b	0.19	0.30
c	0.09	0.20
D	7.70	7.90
E	6.40 BASIC	
E1	4.30	4.50
e	0.65 BASIC	
L	0.45	0.75
$\alpha$	0°	8°
aaa	--	0.10

REFERENCE DOCUMENT: JEDEC PUBLICATION 95, MO-153

**TABLE 8. ORDERING INFORMATION**

Part/Order Number	Marking	Package	Shipping Packaging	Temperature
8308AGI	ICS8308AGI	24 Lead TSSOP	tube	-40°C to 85°C
8308AGIT	ICS8308AGI	24 Lead TSSOP	tape & reel	-40°C to 85°C
8308AGILF	ICS8308AGILF	24 Lead "Lead-Free" TSSOP	tube	-40°C to 85°C
8308AGILFT	ICS8308AGILF	24 Lead "Lead-Free" TSSOP	tape & reel	-40°C to 85°C

NOTE: Parts that are ordered with an "LF" suffix to the part number are the Pb-Free configuration and are RoHS compliant.

While the information presented herein has been checked for both accuracy and reliability, Integrated Device Technology, Incorporated (IDT) assumes no responsibility for either its use or for infringement of any patents or other rights of third parties, which would result from its use. No other circuits, patents, or licenses are implied. This product is intended for use in normal commercial and industrial applications. Any other applications such as those requiring high reliability or other extraordinary environmental requirements are not recommended without additional processing by IDT. IDT reserves the right to change any circuitry or specifications without notice. IDT does not authorize or warrant any IDT product for use in life support devices or critical medical instruments.

REVISION HISTORY SHEET				
Rev	Table	Page	Description of Change	Date
A		11	Added Schematic Layout	4/16/04
B	T4B T4E T5B	1	Features section - added mix supply voltage bullet.	10/20/04
		3	Added Mix Power Supply Table.	
		4	Added Mix DC Characteristics Table.	
		6	Added Mix AC Characteristics Table.	
		8	Added Mix Output Load AC Test Circuit Diagram.	
B	T8	14	Ordering Information Table - added "Lead-Free" part number.	1/12/05
B	T8	1	Corrected Block Diagram, added CLK_SEL.	7/25/05
		10	Added "Recommendations for Unused Input and Output Pins".	
		14	Ordering Information Table - added Lead-Free note.	
B		1	Pin Assignment - corrected package information from 300-MIL to 173-MIL.	8/4/06
B	T3B	2	Added OE Select Function Table.	10/16/07
C	T4F T5A - T5C T8	5	DC Characteristics - corrected VIH min. from 2V to 1.7V; VIL max. from 1.3V to 0.7V.	7/16/09
		5-7	AC Characteristics - added thermal note.	
		14	Ordering Information Table - deleted ICS prefix from Part/Order Number column.	



[www.IDT.com](http://www.IDT.com)

6024 Silver Creek Valley Road  
San Jose, CA 95138

**Sales**

800-345-7015 (inside USA)  
+408-284-8200 (outside USA)  
Fax: 408-284-2775  
[www.IDT.com/go/contactIDT](http://www.IDT.com/go/contactIDT)

**Technical Support**

[netcom@idt.com](mailto:netcom@idt.com)  
+480-763-2056

DISCLAIMER Integrated Device Technology, Inc. (IDT) and its subsidiaries reserve the right to modify the products and/or specifications described herein at any time and at IDT's sole discretion. All information in this document, including descriptions of product features and performance, is subject to change without notice. Performance specifications and the operating parameters of the described products are determined in the independent state and are not guaranteed to perform the same way when installed in customer products. The information contained herein is provided without representation or warranty of any kind, whether express or implied, including, but not limited to, the suitability of IDT's products for any particular purpose, an implied warranty of merchantability, or non-infringement of the intellectual property rights of others. This document is presented only as a guide and does not convey any license under intellectual property rights of IDT or any third parties.

IDT's products are not intended for use in life support systems or similar devices where the failure or malfunction of an IDT product can be reasonably expected to significantly affect the health or safety of users. Anyone using an IDT product in such a manner does so at their own risk, absent an express, written agreement by IDT.

Integrated Device Technology, IDT and the IDT logo are registered trademarks of IDT. Other trademarks and service marks used herein, including protected names, logos and designs, are the property of IDT or their respective third party owners.

Copyright 2009. All rights reserved.