

1 2 3 4

NOTES:

1. MATERIAL:
 CONTACT: PHOSPHOR BRONZE
 BASE: UL 94V-0 PBT, 30%GF
 BASE: UL 94V-0 LCP, 50%GF (ONLY FOR 10057542-1311XLF)
 COVER: UL 94V-0 PBT, 30%GF
 COVER: UL 94V-0 LCP, 50%GF (ONLY FOR 10057542-1311XLF)
2. PLATING:
 GOLD PLATING: SEE PART NUMBER DEFINITION.
 120u" MATTE PURE TIN IN SOLDER TAIL AREA;
 50u" NICKEL UNDERPLATE OVER ALL SURFACES.
3. THIS PRODUCT MEETS EUROPEAN UNION DIRECTIVES AND OTHER COUNTRY REGULATIONS AS DESCRIBED IN GS-22-008.
4. GENERAL TOLERANCE: 0 mm TO 10 mm: ±0.15 mm
 10 mm TO 30 mm: ±0.20 mm
 30 mm TO 60 mm: ±0.3 mm
 >60 mm: ±0.5 mm
5. FLATNESS CONTROL WITHIN 0.25mm MAX.
6. THE HOUSING WILL WITHSTAND EXPOSURE TO 260°C PECK TEMPERATURE FOR 10 SECONDS IN A WAVE SOLDER APPLICATION WITH A 1.6mm MINIMUM THICK CIRCUIT BOARD USE PROTECTIVE ADHESIVE TAPE (KAPTON OR TEFLON) OR PROTECTIVE METALLIC DEVICES ON THE AREAS WHICH ARE DIRECTLY EXPOSED TO WAVE SOLDERING AS IT IS USED IN CLASSICAL LEADED WAVE SOLDERING
7. CUSTOMER CAN FREE CHOOSE THE TWO HOLES ACCORDING TO THEIR REQUIREMENT

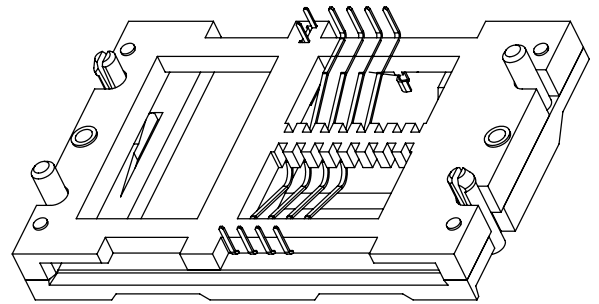

PART NUMBER SCHEME:
10057542-XXXXXLF

- SENSOR TYPE:
 F: BLADE CONTACTS NORMALLY CLOSED.
 A: BLADE CONTACTS NORMALLY OPEN.
- GOLD PLATING THICKNESS:
 1: 0.4um.
 2: 0.8um.
- NUMBER OF CONTACTS:
 1: 8
- PROFILE TYPE:
 1: STANDARD PROFILE(HEIGHT: 9.0)
 2: LOW PROFILE(HEIGHT: 6.5)
 3: DIFFERENT FOOTS FOR LOW INSERT FORCE,
- COVER COLOR:
 1: BLACK.



Copyright FCI.

www.fciconnect.com		surface 6,4 ISO 1302	tolerance std ISO 406 ISO 1101	projection MM	MM
		TOLERANCES UNLESS OTHERWISE SPECIFIED		size A4	Scale 1.000
Dr	AILEI ZHANG	06/22/05	ANGULAR	0.X	±0.3
Eng	AILEI ZHANG	06/22/05	LINEAR	0.XX	±0.15
Chr	AILEI ZHANG	06/22/05	0° ±2°	0.XXX	±0.05
Appr	JASON ZHOU	06/22/05	Product family	ECN	N10-0242
				Spec ref	
FCI		title SMART CARD CONNECTORS		part no	10057542
		catalog no		CUSTOMER	sheet 1 of 4
				Rev.	G

rev	ecn no	dr	date
G	N10-0242	SH	2010-12-27
-	-	-	-
-	-	-	-
-	-	-	-
-	-	-	-

REV F - 2008-06-17

1 2 3 4

PDM: Rev:G

STATUS: Released 4 Printed: Jan 20, 2011



Copyright FCJ

PRODUCT NUMBER
10057542-111XXLF

CRIMPING PART TO USE WITH A THICKNESS PCB OF 1.6 HOLES $\phi=3.2\pm0.06$

$\phi \pm 0.05$ A|B

$\phi 3\pm0.2$
 $\phi \pm 0.05$ A|B

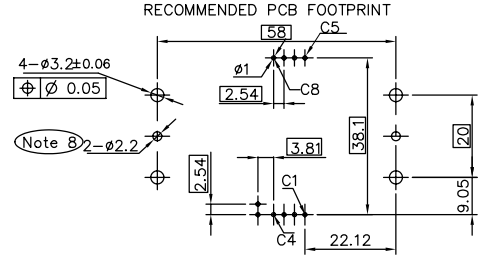
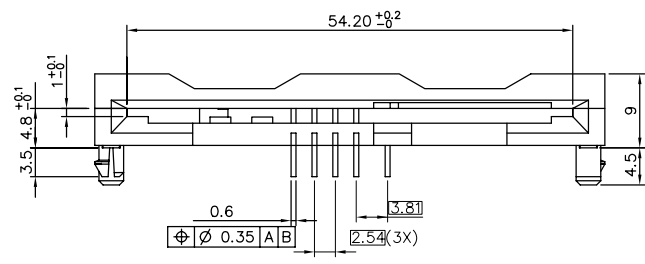
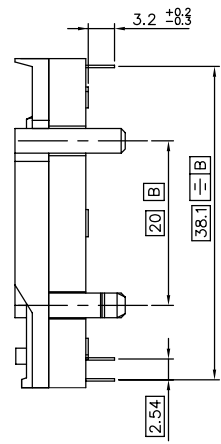
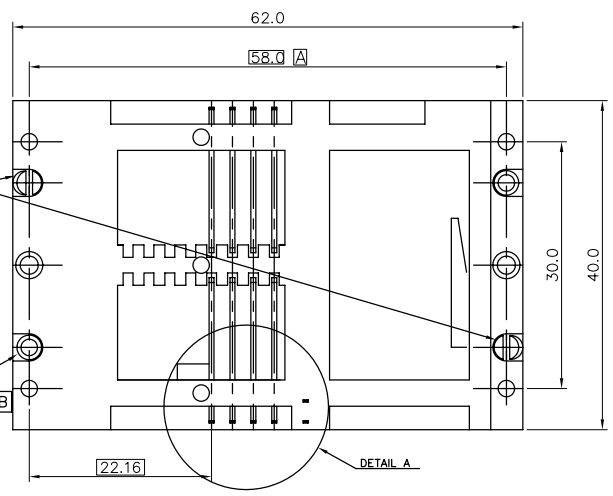

SCALE 2/1

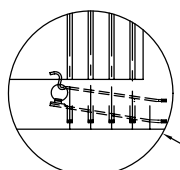

SENSOR TYPE:
A: BLADE CONTACTS NORMALLY OPEN.

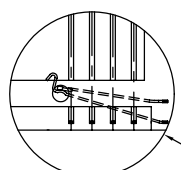

SENSOR TYPE:
F: BLADE CONTACTS NORMALLY CLOSED.

www.fcconnect.com		surface ISO 1302	tolerance std ISO 406 ISO 1101	projection MM
TOLERANCES UNLESS OTHERWISE SPECIFIED		ANGULAR	LINEAR	size A4
Dir	AILEI ZHANG 06/22/05	0x	±0.3	Scale 1.000
Eng	AILEI ZHANG 06/22/05	0.xx	±0.15	ECN N10-0242
Chr	AILEI ZHANG 06/22/05	0° ±2°	0.xxx ±0.05	Spec ref
Appr	JASON ZHOU 06/22/05	Product family		
FCJ	title SMART CARD CONNECTORS	rev 12	10057542	Rev. G
catalog no		CUSTOMER	sheet 2 of 4	

REV F - 2009-06-17

PDM: Rev:G

STATUS: Released 4 Printed: Jan 20, 2011



Copyright FCJ

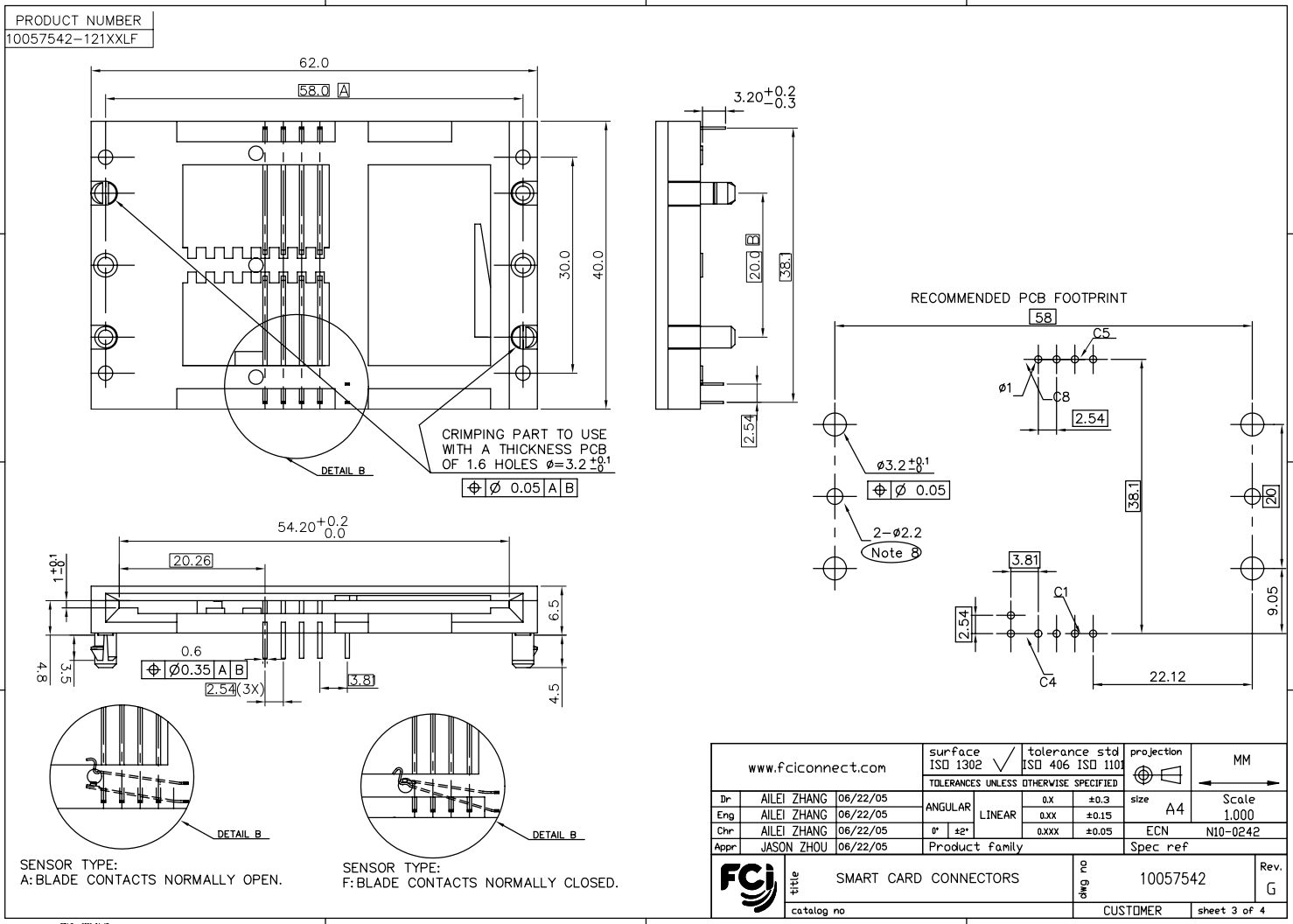

www.fcconnect.com		surface ISO 1302	tolerance std ISO 406 ISO 1101	projection MM
		TOLERANCES UNLESS OTHERWISE SPECIFIED		← →
Dr	AILEI ZHANG 06/22/05	ANGULAR	0.X ±0.3	size A4 Scale 1.000
Eng	AILEI ZHANG 06/22/05	LINEAR	0.XX ±0.15	ECN N10-0242
Chr	AILEI ZHANG 06/22/05	0° ±2°	0.XXX ±0.05	Spec ref
Appr	JASON ZHOU 06/22/05	Product family		
FCJ	title	SMART CARD CONNECTORS		Rev. G
	catalog no	CUSTOMER		sheet 3 of 4

PDM: Rev:G STATUS:Released 4 Printed: Jan 20, 2011



Copyright FCI.

PRODUCT NUMBER
10057542-131XXLF

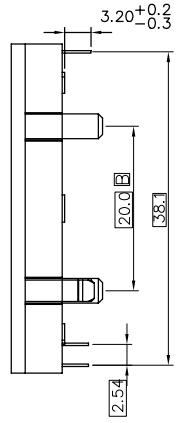
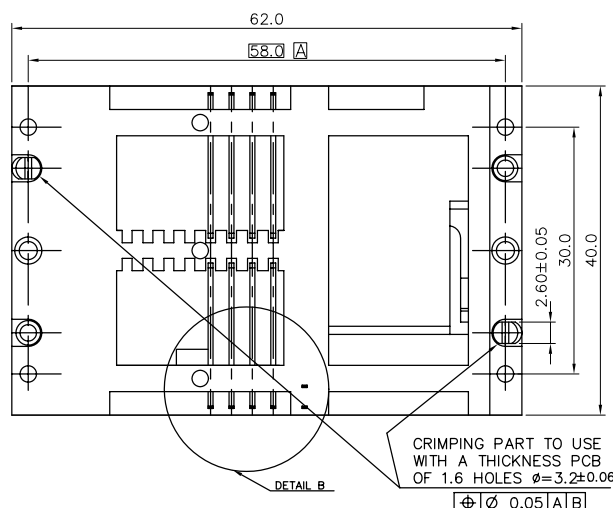

RECOMMENDED PCB FOOTPRINT

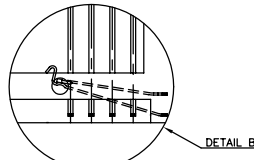
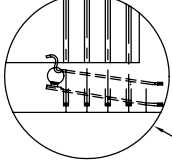
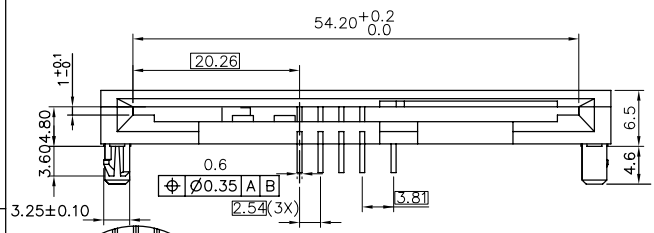
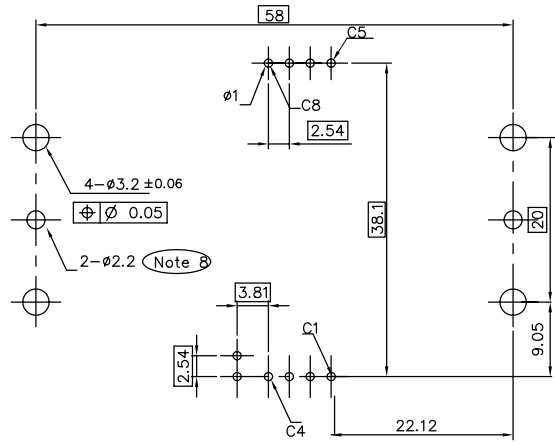

SENSOR TYPE:
A: BLADE CONTACTS NORMALLY OPEN.

SENSOR TYPE:
F: BLADE CONTACTS NORMALLY CLOSED.

www.fciconnect.com		surface ISO 1302	tolerance std ISO 406 ISO 1101	projection MM
		TOLERANCES UNLESS OTHERWISE SPECIFIED		← →
Dr	AILEI ZHANG 06/22/05	ANGULAR	0.X ±0.3	size A4 Scale 1.000
Eng	AILEI ZHANG 06/22/05	LINEAR	0.XX ±0.15	ECN N10-0242
Chr	AILEI ZHANG 06/22/05	0° ±2°	0.XXX ±0.05	Spec ref
Appr	JASON ZHOU 06/22/05	Product family		
FCI	title	SMART CARD CONNECTORS		Rev. G
	catalog no	CUSTOMER		10057542 sheet 4 of 4

REV F - 2008-06-17