

**MARKETING SALES DRAWING**  
**DIMENSIONS IN INCHES - DO NOT SCALE THIS DRAWING**  
**DIMENSIONS IN METRIC - [ ]**

Electrical Testing  
per Tusonix standard  
test plans and Mil-Std-202  
Test Methods.

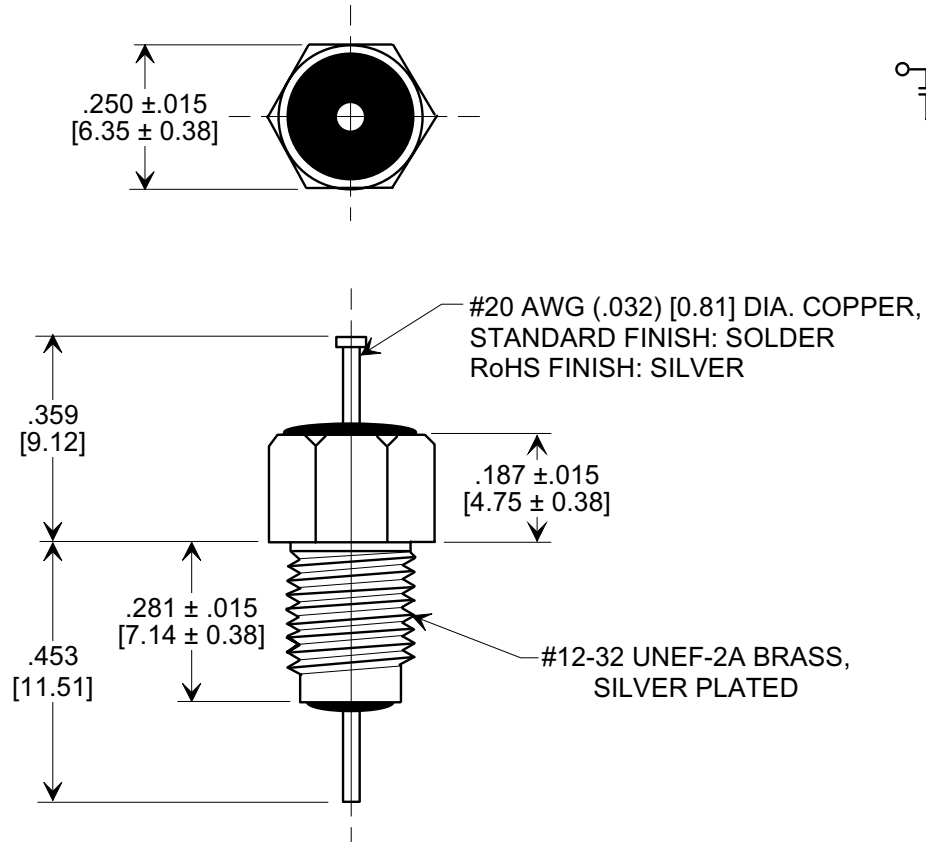
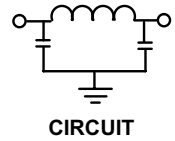
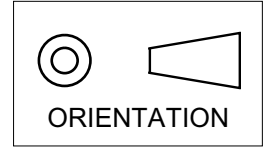

**NOTES:**

- SUPPLIED WITH SILVER PLATED HEX NUT AND LOCK WASHER.
- TUSONIX STANDARD PART NUMBER: 4202-051.  
TUSONIX RoHS COMPLIANT PART NUMBER: 4202-051 LF.  
CUSTOMER MUST SPECIFY STANDARD OR RoHS PART NUMBER WHEN ORDERING.
- PART MARKING: TRADEMARK AND VARIATION NUMBER ON HEX FLATS.  
STANDARD PART: BLACK INK. RoHS PART: GREEN INK.

MIN. CAP. (pF)	WORKING VOLTAGE (VDC)		CURRENT (Idc)	I.R. MIN. @ 100 (VDC.)	DWV (VDC)	MINIMUM NO LOAD INSERTION LOSS (dB) AT 25°C PER MIL-STD -220			
	85°C	125°C				10 MHz	100 MHz	1 GHz	10 GHz
5000	200	100	10 A	10 G	400	20	65	70	70

X-2015 Rev-0	<b>REVISION RECORD</b>		<b>0</b> Original Release C.O. <b>1653</b>  <b>1</b> CURRENT UNIT "A" ADDED. L.E. 8-20-85 <b>2595</b>  RDN TO COMP FMT & ADDED METRIC. 05-22-02 <b>2</b> ADDED NOTES, IR & DWV. S.M. 05-19-05 <b>20020522-6-01</b>  <b>3</b> <b>20050503-6-26</b>	--TOLERANCES-- Unless Otherwise Specified		Title	
	DECIMAL ± .031 [0.79]			BUSHING STYLE EMI FILTER		Scale 3 X	
	ANGLES ±			TUSONIX		Approved J.Mc. 05-22-02	
	TUCSON, ARIZONA			A		4202-051	