

Features

- Radial Leaded Devices
- Cured, flame retardant epoxy polymer insulating material meets UL 94V-0 requirements
- Agency recognition:   
- RoHS compliant*

 The MF-RX Series is currently available, although not recommended for new designs. The higher voltage rated MF-RX/72 Series is preferred.

BOURNS®

MF-RX Series - PTC Resetttable Fuses

Electrical Characteristics

Model	V max. Volts	I max. Amps	I_{hold}		I_{trip}		Initial Resistance		1 Hour (R_1) Post-Trip Resistance	Max. Time To Trip		Tripped Power Dissipation
			Amperes at 23 °C		Ohms at 23 °C		Ohms at 23 °C		Ohms at 23 °C	Amperes at 23 °C	Seconds at 23 °C	Watts at 23 °C
			Hold	Trip	Min.	Max.	Max.			Typ.		
MF-RX110	60	40	1.10	2.20	0.15	0.25	0.38	5.5	8.2	1.50		
MF-RX135	60	40	1.35	2.70	0.12	0.19	0.30	6.75	9.6	1.70		
MF-RX160	60	40	1.60	3.20	0.09	0.14	0.22	8.0	11.4	1.90		
MF-RX185	60	40	1.85	3.70	0.08	0.12	0.19	9.25	12.6	2.10		
MF-RX250	60	40	2.50	5.00	0.05	0.08	0.13	12.5	15.6	2.50		
MF-RX300	60	40	3.00	6.00	0.04	0.06	0.10	15.0	19.8	2.80		
MF-RX375	60	40	3.75	7.50	0.03	0.05	0.08	18.75	24.0	3.20		

Environmental Characteristics

Operating/Storage Temperature-40 °C to +85 °C
 Maximum Device Surface Temperature
 in Tripped State125 °C
 Passive Aging.....+85 °C, 1000 hours±5 % typical resistance change
 Humidity Aging.....+85 °C, 85 % R.H. 1000 hours.....±5 % typical resistance change
 Thermal Shock-40 °C to +85 °C, 10 times±10 % typical resistance change
 Solvent ResistanceMIL-STD-202, Method 215No change
 VibrationMIL-STD-883C, Method 2007.1,No change
 Condition A

Test Procedures And Requirements For Model MF-RX Series

Test	Test Conditions	Accept/Reject Criteria
Visual/Mech.	Verify dimensions and materials.....	Per MF physical description
Resistance	In still air @ 23 °C.....	$R_{min} \leq R \leq R_{max}$
Time to Trip	5 times I_{hold} , V_{max} , 23 °C.....	$T \leq \text{max. time to trip (seconds)}$
Hold Current	30 min. at I_{hold}	No trip
Trip Cycle Life	V_{max} , I_{max} , 100 cycles.....	No arcing or burning
Trip Endurance	V_{max} , 48 hours.....	No arcing or burning
UL File Number	E 174545S	
CSA File Number	CA 110338	
TÜV File Number	R2057213	

Thermal Derating Chart - I_{hold} / I_{trip} (Amps)

Model	Ambient Operating Temperature									
	-40 °C	-20 °C	0 °C	23 °C	40 °C	50 °C	60 °C	70 °C	85 °C	
MF-RX110	1.71 / 3.42	1.50 / 3.00	1.31 / 2.62	1.10 / 2.20	0.89 / 1.78	0.79 / 1.58	0.69 / 1.38	0.59 / 1.18	0.44 / 0.88	
MF-RX135	2.09 / 4.18	1.84 / 3.68	1.61 / 3.22	1.35 / 2.70	1.09 / 2.18	0.97 / 1.94	0.85 / 1.70	0.73 / 1.46	0.54 / 1.08	
MF-RX160	2.48 / 4.96	2.18 / 4.36	1.90 / 3.80	1.60 / 3.20	1.30 / 2.60	1.15 / 2.30	1.01 / 2.02	0.86 / 1.72	0.64 / 1.28	
MF-RX185	2.87 / 5.74	2.52 / 5.04	2.20 / 4.40	1.85 / 3.70	1.50 / 3.00	1.33 / 2.66	1.17 / 2.34	1.00 / 2.00	0.74 / 1.48	
MF-RX250	3.88 / 7.76	3.40 / 6.80	2.98 / 5.96	2.50 / 5.00	2.03 / 4.06	1.80 / 3.60	1.58 / 3.16	1.35 / 2.70	1.00 / 2.00	
MF-RX300	4.65 / 9.30	4.08 / 8.16	3.57 / 7.14	3.00 / 6.00	2.43 / 4.86	2.16 / 4.32	1.89 / 3.78	1.62 / 3.24	1.20 / 2.40	
MF-RX375	5.81 / 11.6	5.10 / 10.2	4.46 / 8.92	3.75 / 7.50	3.04 / 6.08	2.70 / 5.40	2.36 / 4.72	2.03 / 4.06	1.50 / 3.00	

*RoHS Directive 2002/95/EC Jan 27 2003 including Annex. Specifications are subject to change without notice. Customers should verify actual device performance in their specific applications.

Additional Features

- Bulk packaging, tape and reel and Ammo-Pak available on most models
- Resettable circuit protection
- Patents pending

Applications

- Almost anywhere there is a low voltage power supply, up to 60 V and a load to be protected, including:
- Security and fire alarm systems
 - Loud speakers
 - Power transformers

MF-RX Series - PTC Resettable Fuses

BOURNS®

Product Dimensions

Model	A	B	C		D	E	Physical Characteristics		
	Max.	Max.	Nom.	Tol. ±	Min.	Max.	Style	Lead Dia.	Material
MF-RX110	13.0 (0.512)	18.0 (0.709)	5.1 (0.201)	0.7 (0.028)	7.6 (0.299)	3.1 (0.122)	1	0.81 (0.032)	Sn/Cu
MF-RX135	14.5 (0.571)	19.6 (0.772)	5.1 (0.201)	0.7 (0.028)	7.6 (0.299)	3.1 (0.122)	1	0.81 (0.032)	Sn/Cu
MF-RX160	16.3 (0.642)	21.3 (0.839)	5.1 (0.201)	0.7 (0.028)	7.6 (0.299)	3.1 (0.122)	1	0.81 (0.032)	Sn/Cu
MF-RX185	17.8 (0.701)	22.9 (0.902)	5.1 (0.201)	0.7 (0.028)	7.6 (0.299)	3.1 (0.122)	1	0.81 (0.032)	Sn/Cu
MF-RX250	21.3 (0.839)	26.4 (1.039)	10.2 (0.402)	0.7 (0.028)	7.6 (0.299)	3.1 (0.122)	1	0.81 (0.032)	Sn/Cu
MF-RX300	24.9 (0.980)	30.0 (1.181)	10.2 (0.402)	0.7 (0.028)	7.6 (0.299)	3.1 (0.122)	1	0.81 (0.032)	Sn/Cu
MF-RX375	28.4 (1.118)	33.5 (1.319)	10.2 (0.402)	0.7 (0.028)	7.6 (0.299)	3.1 (0.122)	1	0.81 (0.032)	Sn/Cu

Packaging options:

BULK: All models = 500 pcs. per bag.

TAPE & REEL: MF-RX110 – MF-RX160 = 1500 pcs. per reel; MF-RX185 – MF-RX375 = 1000 pcs. per reel

AMMO-PACK: MF-RX110 – MF-RX160 = 1000 pcs. per reel; MF-RX185 – MF-RX375 = 500 pcs. per reel

0.81 (20AWG)

DIMENSIONS = $\frac{\text{MM}}{\text{(INCHES)}}$

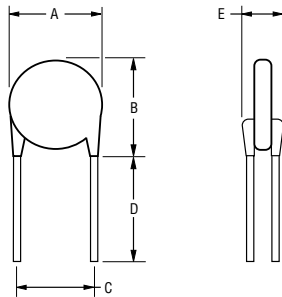

NOTE: Kinked lead option is available for board standoff. Contact factory for details.

Typical Part Marking

Represents total content. Layout may vary.

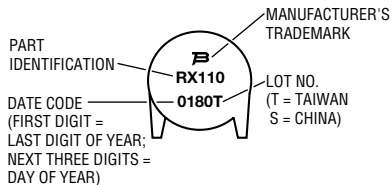

How to Order

MF - RX 110 - 0 - 99

- Multifuse®
Product Designator
- Series
RX = Radial Leaded Component
- Hold Current, I_{hold}
110-375 (1.10 Amps - 3.75 Amps)
- Packaging Options
- = Bulk Packaging without part number suffix option
 - 0-99 = Bulk Packaging with part number suffix option
 - 2 = Tape and Reel without part number suffix option*
 - 2-99 = Tape and Reel with part number suffix option
 - AP = Ammo-Pak*
 - 0-14 = Kinked leads where straight leads are standard
 - 0-17 = Straight leads where kinked leads are standard
- Part Number Suffix Option
- 99 = As of date code April 1, 2005 all MF-RX models are RoHS compliant. The suffix "-99" can be used if a new part number is required to reference the RoHS compliance.
- Examples:
- MF-RX110Bulk packaging
- MF-RX110-0-99Bulk packaging with part number suffix option
- MF-RX110-2Tape and reel packaging
- MF-RX110-2-99Tape and reel packaging with part number suffix option

*Packaged per EIA486-B

Typical Time to Trip at 23 BC

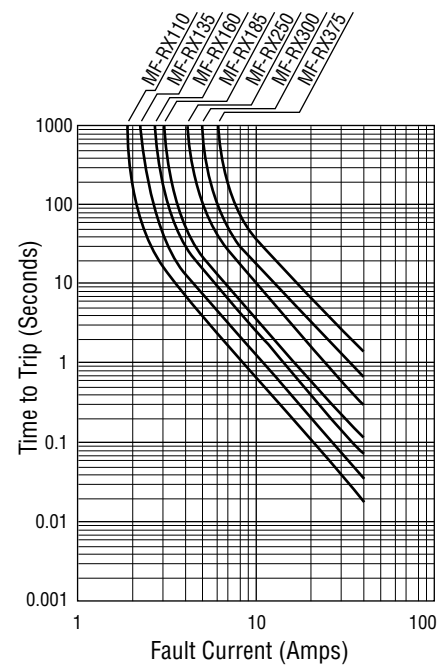

Specifications are subject to change without notice.
Customers should verify actual device performance in their specific applications.

MF-RX SERIES, REV. L, 02/06

**MF-R, MF-RX, MF-R/90, MF-RX/72 & MF-RX/250 Series
Tape and Reel Specifications**

BOURNS®

Devices taped using EIA468-B/IEC286-2 standards. See table below and Figures 1 and 2 for details.

Dimension Description	IEC Mark	EIA Mark	Dimensions	
			Dimensions	Tolerance
Carrier tape width	W	W	$\frac{18}{(.709)}$	$\frac{-0.5/+1.0}{(-0.02/+0.039)}$
Hold down tape width: all others	W_0	W_4	$\frac{11}{(.433)}$	min.
Hold down tape			No protrusion	
Top distance between tape edges	W_2	W_6	$\frac{3}{(.118)}$	max.
Sprocket hole position	W_1	W_5	$\frac{9}{(.354)}$	$\frac{-0.5/+0.75}{(-0.02/+0.03)}$
Sprocket hole diameter	D_0	D_0	$\frac{4}{(.157)}$	$\frac{\pm 0.2}{(\pm .0078)}$
Abscissa to plane (straight lead)	H	H	$\frac{18.5}{(.728)}$	$\frac{\pm 3.0}{(\pm .118)}$
Abscissa to plane (kinked lead)	H_0	H_0	$\frac{16}{(.63)}$	$\frac{\pm 0.5}{(\pm .02)}$
Abscissa to top (straight lead)	H_1	H_1	$\frac{38.0}{(1.496)}$	max.
Abscissa to top (kinked lead)	H_1	H_1	$\frac{32.2}{(1.268)}$	max.
Overall width w/lead protrusion (straight lead)		C_1	$\frac{55.0}{(2.165)}$	max.
Overall width w/lead protrusion (kinked lead)		C_1	$\frac{43.2}{(1.7)}$	max.
Overall width w/o lead protrusion (straight lead)		C_2	$\frac{54.0}{(2.126)}$	max.
Overall width w/o lead protrusion (kinked lead)		C_2	$\frac{42.5}{(1.673)}$	max.
Lead protrusion	l_1	L_1	$\frac{1.0}{(.039)}$	max.
Protrusion of cutout	L	L	$\frac{11}{(.433)}$	max.
Protrusion beyond hold tape	l_2	l_2	Not specified	
Sprocket hole pitch	P_0	P_0	$\frac{12.7}{(0.5)}$	$\frac{\pm 0.3}{(\pm .012)}$
Pitch tolerance			20 consecutive	± 1
Device pitch: MF-R005–MF-R160, MF-R/90 & MF-RX/72			$\frac{12.7}{(0.5)}$	
Device pitch: MF-R185–MF-R400, MF-RX110–MF-RX375			$\frac{25.4}{(1.0)}$	
Tape thickness	t	t	$\frac{0.9}{(.035)}$	max.
Tape thickness with splice: MF-R010–MF-R160		t_1	$\frac{1.5}{(.059)}$	max.
Tape thickness with splice: MF-R250–MF-R1100 MF-RX110–MF-RX375 & MF-R/90		t_1	$\frac{2.3}{(.091)}$	max.
Splice sprocket hole alignment			0	$\frac{\pm 0.3}{(\pm .012)}$
Body lateral deviation	Δh	Δh	0	$\frac{\pm 1.0}{(\pm .039)}$
Body tape plane deviation	Δp	Δp	0	$\frac{\pm 0.3}{(\pm .021)}$
Lead spacing	F	F	$\frac{5.08}{(0.2)}$	$\frac{\pm 0.2}{(\pm .008)}$
Reel width	w	W_2	$\frac{56}{(2.205)}$	max.
Reel diameter	d	a	$\frac{370}{(14.57)}$	max.
Space between flanges less device	W_1	h	$\frac{4.75}{(.187)}$	$\frac{\pm 3.25}{(\pm .128)}$

Specifications are subject to change without notice.
Customers should verify actual device performance in their specific applications.

DIMENSIONS = $\frac{\text{MM}}{\text{(INCHES)}}$

**MF-R, MF-RX, MF-R/90, MF-RX/72 & MF-RX/250 Series
Tape and Reel Specifications**

BOURNS®

Dimension Description	IEC Mark	EIA Mark	Dimensions	
			Dimensions	Tolerance
Arbor hole diameter	<i>f</i>	<i>c</i>	$\frac{26}{(1.024)}$	$\frac{\pm 12.0}{(\pm .472)}$
Core diameter: MF-R, MF-RX, MF-R/90	<i>h</i>	<i>n</i>	$\frac{80}{(3.15)}$	max.
Box: MF-R, MF-RX, MF-R/90			$\frac{56}{(2.2)}$ $\frac{372}{(14.6)}$ $\frac{372}{(14.6)}$	max.
Consecutive missing places: MF-R, MF-RX, MF-R/90			3	max.
Empty places per reel: MF-R, MF-RX, MF-R/90			Not specified	

Taped Component Dimensions - Figure 1

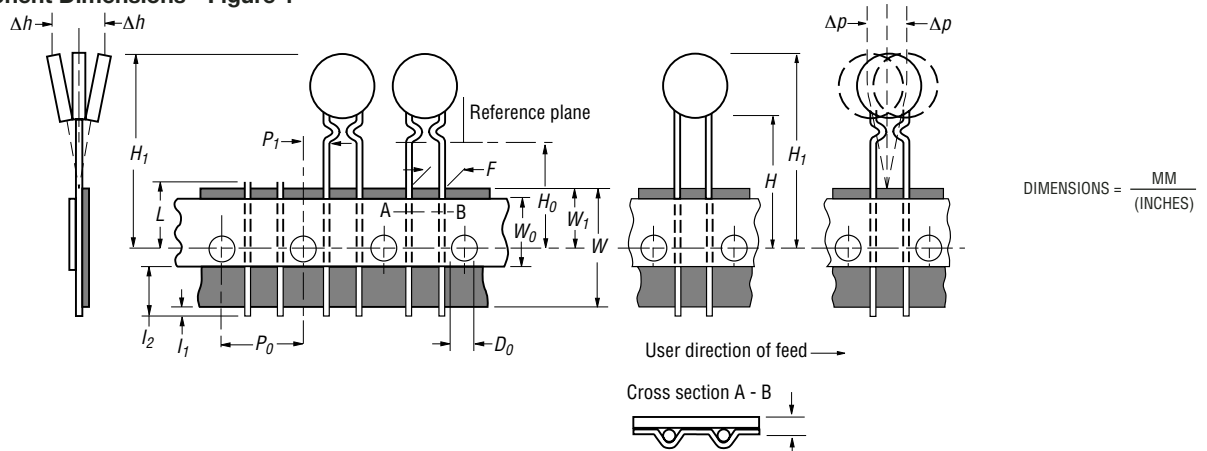

Reel Dimensions - Figure 2

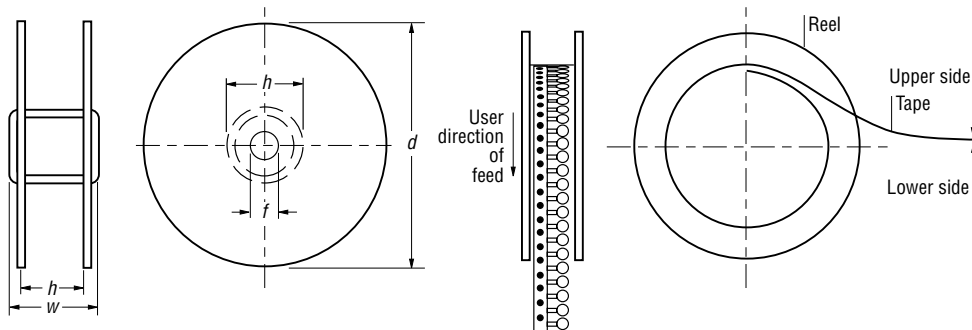

Specifications are subject to change without notice.
Customers should verify actual device performance in their specific applications.