



MSL1

* Pb Free Part

Customer Name	Standard specification	TAIYO YUDEN Mobile Technology Co.,Ltd.	
System	DCS-Tx (unbalance)	Date	March 31, 2010
Part Number	FAR-F6KA-1G7475-D4CY	Version 3.0c	

Table 1. Electrical specification

Passband: 1710 ~ 1785 MHz						
Item	Condition	Specification				Remark
		Min.	Typ.	Max.	Unit	
Insertion Loss	1710 – 1785 MHz	–	2.5	2.9	dB	+25+/- 2°C
		–	–	3.6	dB	– 30~+85°C
Ripple	1710 – 1785 MHz	–	1.3	2.2	dB	
Absolute Attenuation	DC – 1000 MHz	35	45	–	dB	
	1000 – 1600 MHz	25	33	–	dB	
	1600 – 1690 MHz	6	9	–	dB	
	1805 – 1880 MHz	26	30	–	dB	+25+/- 2°C
		24	–	–	dB	– 20~+85°C
		20	–	–	dB	– 30~+85°C
	2000 – 2500 MHz	30	36	–	dB	
	2500 – 3000 MHz	25	32	–	dB	
	3000 – 4000 MHz	20	27	–	dB	
4000 – 6000 MHz	15	21	–	dB		
VSWR(Input)	1710 – 1785 MHz	–	2.3	2.8	–	
VSWR(Output)	1710 – 1785 MHz	–	2.5	3.0	–	
Input Impedance		50//12nH			Ohm	
Output Impedance		50			Ohm	
Device size		1.4typ.x1.0typ.x0.5max.			mm	
Operating temp.		-30 ~ +85			°C	

TAIYO YUDEN



MSL1

* Pb Free Part

Customer Name	Standard specification	TAIYO YUDEN Mobile Technology Co.,Ltd.	
System	DCS-Tx (unbalance)	Date	March 31, 2010
Part Number	FAR-F6KA-1G7475-D4CY	Version 3.0c	

Dimensions

Device size: 1.4typ. x 1.0typ. x 0.5max.

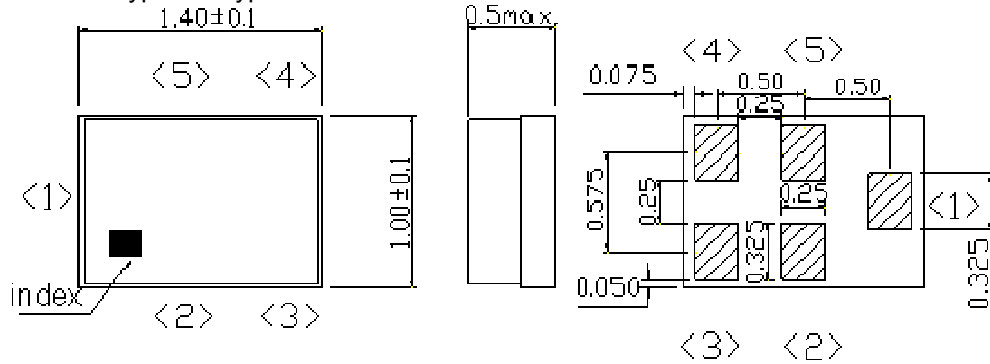

Unit: mm

Pin Configuration

Pin No.	Symbol	Function
1	IN	Input pin
2	GND	Ground
3	GND	Ground
4	OUT	Output pin
5	GND	Ground

Evaluation Circuit

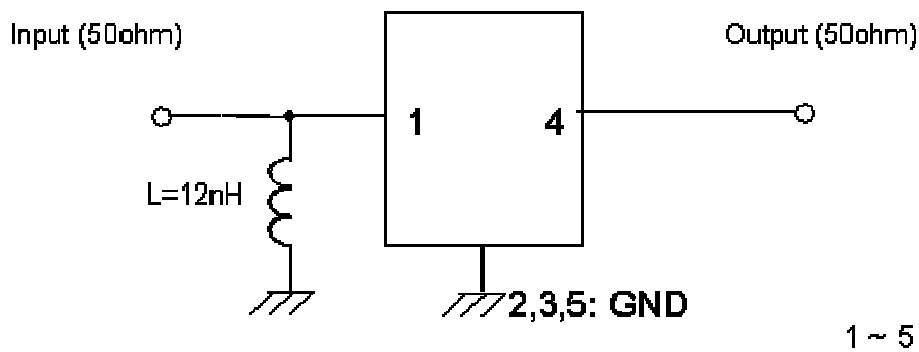

TAIYO YUDEN



MSL1

* Pb Free Part

Customer Name	Standard specification	TAIYO YUDEN Mobile Technology Co.,Ltd.	
System	DCS-Tx (unbalance)	Date	March 31, 2010
Part Number	FAR-F6KA-1G7475-D4CY	Version 3.0c	

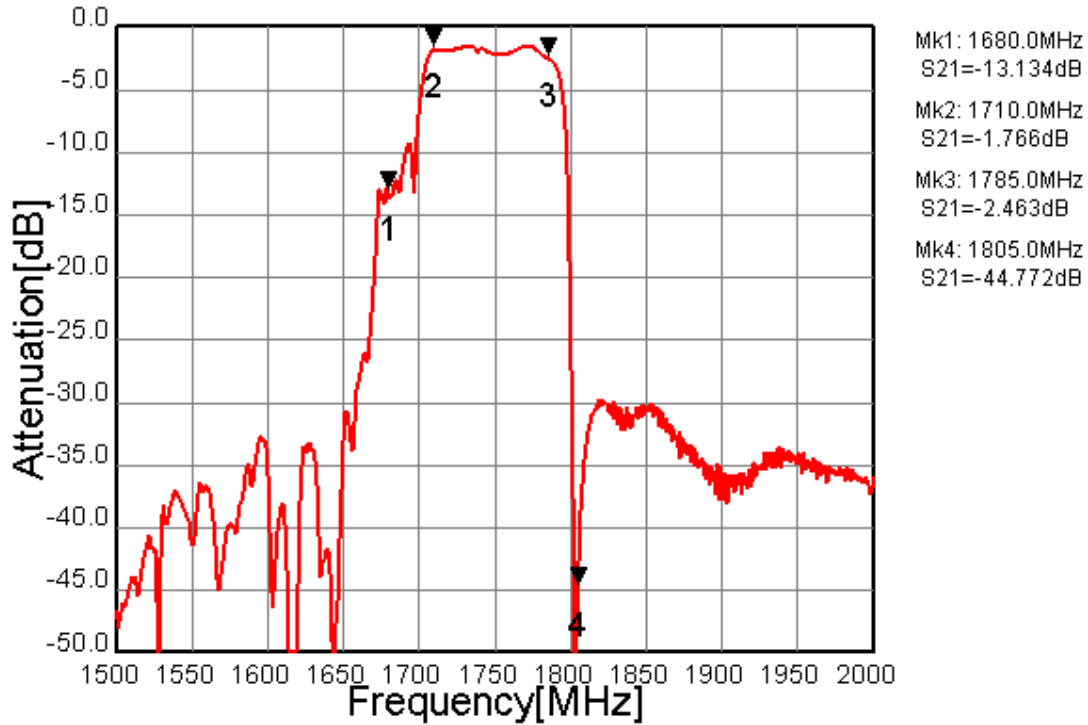

Fig.1 Pass-band Characteristic

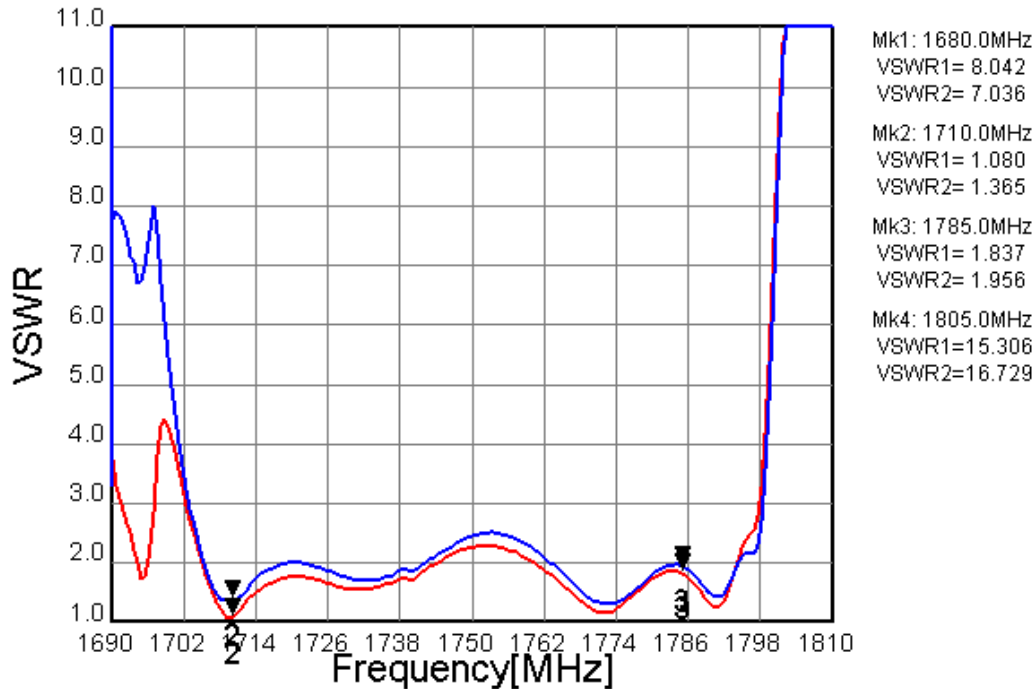

Fig.2 VSWR

— S11
— S22

TAIYO YUDEN



MSL1

* Pb Free Part

Customer Name	Standard specification	TAIYO YUDEN Mobile Technology Co.,Ltd.	
System	DCS-Tx (unbalance)	Date	March 31, 2010
Part Number	FAR-F6KA-1G7475-D4CY	Version 3.0c	

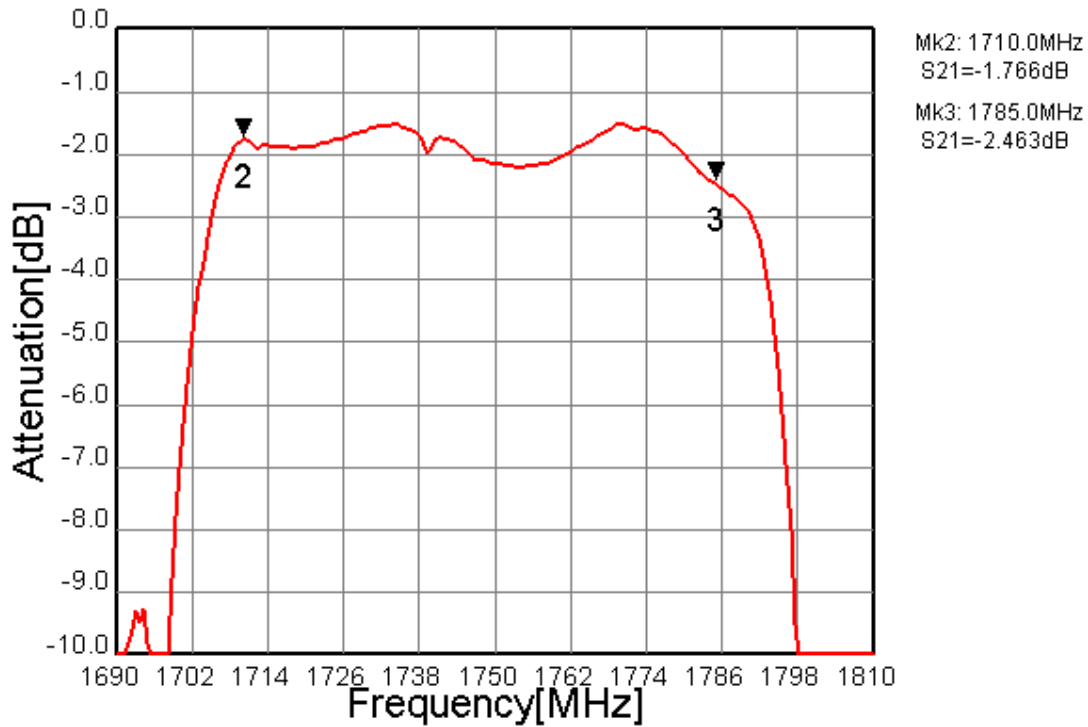

Fig.3 In-band Characteristic

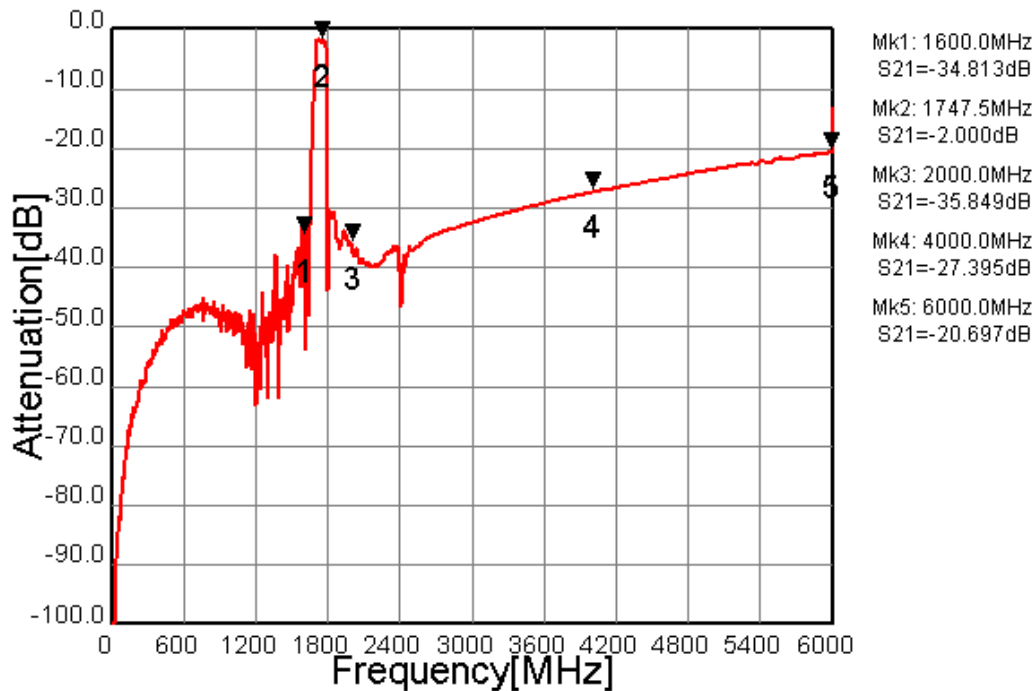

Fig.4 Wide-band Characteristic

TAIYO YUDEN



MSL1

* Pb Free Part

Customer Name	Standard specification	TAIYO YUDEN Mobile Technology Co.,Ltd.	
System	DCS-Tx (unbalance)	Date	March 31, 2010
Part Number	FAR-F6KA-1G7475-D4CY	Version 3.0c	

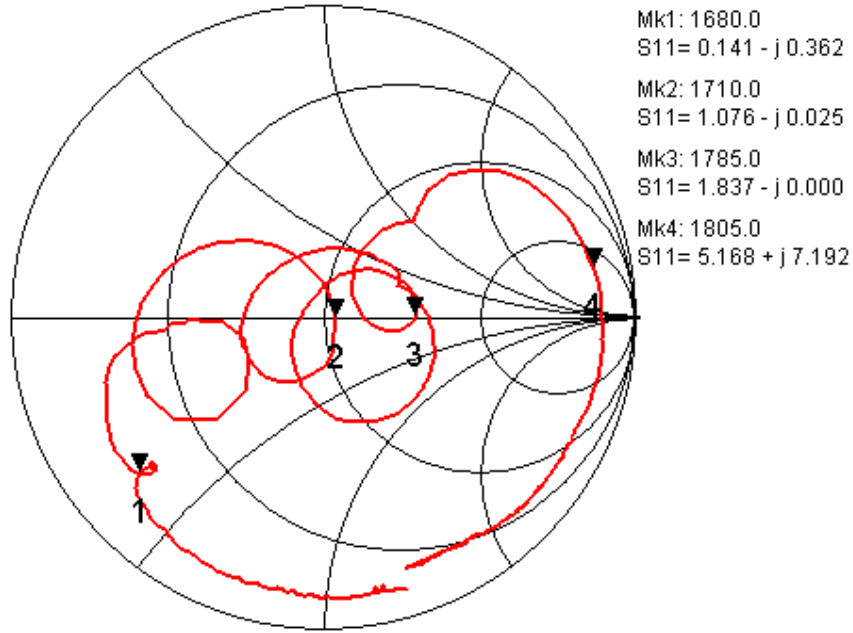

Fig.5 Input Impedance

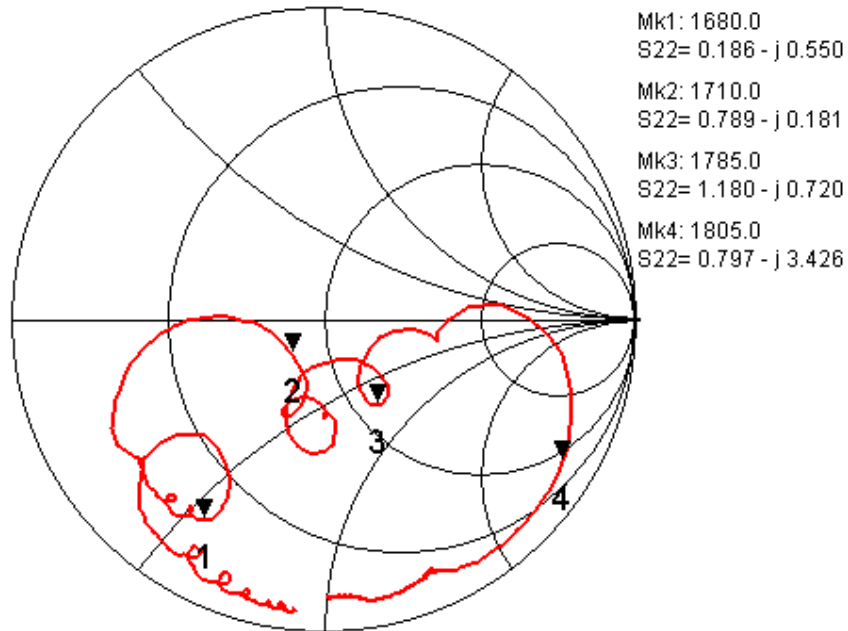

Fig.6 Output Impedance

TAIYO YUDEN