

FAN MOTORS



A  **Minebea** Company

Personal Service ... Global Reach

Vision



Strength



Innovation



Service



Solutions



Quality



Success



NMB Technologies Corporation

NMB Technologies Corporation is a subsidiary of NMB (USA) Inc., the North American headquarters and operating center of the Minebea Group of Companies. Minebea Co., Ltd., was established in 1951 as Japan's first specialized manufacturer of miniature ball bearings. Today, the Company is the world's leading comprehensive manufacturer of miniature ball bearings and high precision components, supplying customers worldwide in the



(NMB Technologies Corporation – Chatsworth, California)

information and telecommunications equipment industry, as well as aerospace, automotive and household electrical appliance industry. The Minebea Group consists of 44 subsidiaries and affiliates in 13 countries, including Japan, Thailand, China, and Singapore as well as several others in Europe and the Americas. The Group maintains 28 plants, 20 R&D bases and 43 sales offices, and employs over 47,000 people worldwide. NMB offers a comprehensive line of more than 100 axial fans ranging in size from 25mm to 173mm. DC and AC axial fans and blowers are designed to solve thermal management problems for our OEM customers. Producing over 100 million fans per year, NMB's focus is on total thermal management solutions. NMB Technologies Corporation's domestic headquarters are located in Chatsworth, California. Highly trained application engineers, experienced product managers and customer service representatives work closely with customers to develop the most cost effective solution for today's challenging applications. Pre-design and after-delivery follow up assure complete customer satisfaction. Contact NMB Technologies Corporation today. Visit our web site at www.nmbtc.com or call our Fan Product Group directly at 818-341-3355. Be part of our Personal Service...Global Reach.

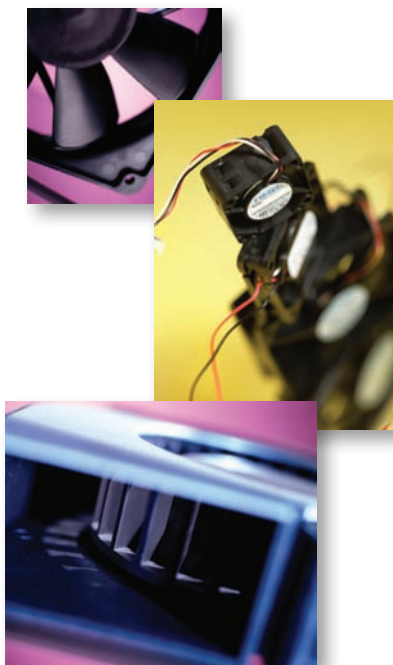

Innovation through integration



(Photos from top to bottom: Minebea's Shanghai Factory, Minebea's Karuizawa – Japan, Cool Tech in Arizona)

Minebea Company, Ltd. and Matsushita Motor Corporation established in 2004 a new joint venture company under the NMB-MAT brand. This business integration unites the super-precision instrument processing technology, mass production technology, and cost competitiveness of Minebea with the innovative product development power of Matsushita Electric Industrial. Using advanced production engineering and the product development technologies of Matsushita and Minebea, the two companies integrate all functions of the information equipment motor business from development to manufacturing and sales.

Manufacturing & Engineering Capabilities

Cooling fan manufacturing operations in *Shanghai, China* produce over 100 million fans per year using highly automated, ultra-precision assembly and test technology. Our unique vertical process integrates in-house production of precision ball bearings, injection molded cases and impellers, high-speed metal press parts, copper windings, and printed circuit assemblies.

Fan engineering headquarters in *Karuizawa, Japan*, leads our global technical centers in the development of high volume fan design, miniature fans, and automated production technology.

At our U.S. *Cooling Technologies* design center in Arizona, we focus on custom design for our U.S. based OEMs. Aerodynamics, microprocessor controls and acoustic management are among our core competencies. NMB's engineers work closely with our customers in the PC, server, and communications sectors to create innovative solutions for unique cooling needs. Specialty motors and assemblies developed by our European engineering groups provide additional technology options.



TABLE OF CONTENTS

DC Axial Fans

Common Specifications and Part Numbering System.....	1.1
1004KL	1.2
1204KL	1.3
1404KL	1.4
1604KL	1.5
1606KL	1.6
1608KL	1.7
1611RL	1.8
2004KL	1.9
2106KL	1.10
2404KL	1.11
2406KL	1.12
2408NL	1.13
2410ML	1.14
2410ML-X	1.15
2415KL	1.16
2810KL	1.17
3106KL	1.18
3108NL	1.19
3110KL	1.20
3112KL	1.21
3610KL	1.22
3610KL-X	1.23
3612KL	1.24
3615KL	1.25
FBA10J12L	1.26
4710KL	1.27
4712FL	1.28
4712KL	1.29
4715KL	1.30
4715KL- 3B	1.31
4715SL	1.32
FBA10B14L	1.33
FBA11J10M/14L	1.34
FBA12J12M	1.35
5015KL	1.36
5020KL	1.37
FBX14	1.38
5910PL	1.39
5920PL	1.40
6820PL	1.41

DC Axial Fans



DC Motorized Impellers



DC Blowers



AC Axial Fans



NMB

Table of Contents

DC Motorized Impellers

About DC Motorized Impellers.....	2.1
Part Numbering System	2.2
101R057	2.3
175R069	2.4
190R071	2.5
220R071	2.6
225R099	2.7
250R100	2.8
280R125	2.9

DC Blowers

Common Specifications and Part Numbering System.....	3.1
BM4515	3.2
FAL3F	3.3
BM5115	3.4
BM5125	3.5
BM6015	3.6
BM6025	3.7
BG0702	3.8
BG0703	3.9
FAL5F	3.10
BG0801	3.11
BG0903	3.12
BG1002	3.13
FAL6F	3.14
BG1203	3.15
BL4447	3.16

AC Axial Fans

Common Specifications and Part Numbering System.....	4.1
2412PS	4.2
3110PS	4.3
3115FS	4.4
3115PS	4.5
3610PS	4.6
4710PS	4.7
4715FS	4.8
4715MS	4.9-4.10
5915PC	4.11

Agency Approvals

.....	5.1
-------	-----

Fan Engineering

.....	6.1-6.8
-------	---------

Accessories

.....	7.1-7.2
-------	---------

Warranty

.....	8.1
-------	-----



Common Specifications

- Vibration Test: Conforms to JIS C 60068-2-6, Amplitude: 1.5mm, Frequency 10 to 55 Hz, 1 hour. In each of the X, Y and Z directions.
- Shock Test: Conforms to JIS C 60068-2-27, Acceleration 981 m/s²*, Application time 6ms, Once each in the X, Y and Z directions. Note: 1004KL, 1204KL, 1404KL, 1604KL, 1606KL, 1608KL, 2004KL, 2106KL, 2404KL, 2406KL, BM4515, BM5115, BM5125 and BM6015 Series The conditions of shock test on the listed models are as follows, Acceleration rate: 500 m/s², Application time: 11ms, Once each in the X, Y and Z directions.
- Locked Rotor Protection : .. The motor is protected from burnout in the locked rotor condition for 72 hours, at the rated voltage.
- Polarity Protection : The fans are Reverse Polarity protected at the rated voltage.
- Insulation Class : E class (UL: Class A)
- Auto Restart:..... Most fan models provide current shut-down/auto restart function under locked rotor conditions.

Notes: Additional performance requirements can be determined between manufacturer and customer, based on customer's request. Ball bearing fans may be installed in a horizontal, vertical or angled position

Part Numbering System

- | | | | | | | | | | | | | | | |
|--|----|----|---|---|---|----|---|---|---|---|---|---|---|----|
| | | | | | | | | | | | | | | |
| | 24 | 10 | M | L | - | 04 | W | - | B | 1 | 0 | - | X | 00 |
| | ① | ② | ③ | ④ | | ⑤ | ⑥ | | ⑦ | ⑧ | ⑨ | | ⑩ | ⑪ |
- Frame Size
10:25mm
12:30mm
14:35mm
16:40mm
20:50mm
21:52mm
24:60mm
28:70mm
31:80mm
36:92mm
47:119mm
50:127mm
59:150mm
68:172mm
 - Overall Length (Thickness)
04:10mm
06:15mm
08:20mm
10:25mm
12:32mm
15:38mm
20:50mm
 - Series
P Series
M Series
N Series
K Series
H Series
S Series
F Series
R Series
 - Motor Function
Brushless Type DCM
 - Input Voltage
O: Standard Current
C: Special Current
D~Z: Special Current (A.B.O. are not used)
1: 5V 5: 24V
2: 6V 6: 36V
3: 9v 7: 48V
4: 12V 9: Other
 - Termination
W: Lead Wires
T: Terminal
(Terminal option on 3610KL and 4715KL Series)
 - Bearing
B: Ball Bearing
S: Sleeve Bearing
 - Speed
1<2<3<4<5<6<7<8
low high
 - Special Control Function
0: Standard Type
9: Sensor Type
7: Temperature Detecting Variable Speed Type/PWM Control Type
6: Temperature Detecting Variable Speed Type/Sensor Type
5: 2-Speed Type/Sensor Type
8: 2-Speed Type
 - Product Number

Item	Classification	Mounting Style
L:	Standard Model	Rib Type
P:	Standard Model	Flange Type
B:	Standard Model	Rib Type
E:	Standard Model	Flange Type
G:	Standard Model	Rib Type
D:	Standard Model	Flange Type
T:	Value Model	Rib Type
S:	Value Model	Flange Type
C:	Value Model	Rib Type
F:	Value Model	Flange Type
J:	Value Model	One Side Rib Type
H:	Value Model	One Side Flange Type
M:	Value Model	Rib Type
V:	Value Model	Flange Type
X:	Vented Casing	Flange Type
 - Individual Specifications
Standard
00 Standard
01~99: Custom
Sensor Type
00: Locked Rotor Alarm Signal (Standard)
01~49: Locked Rotor Alarm Signal (Custom)
50: Tachometer Signal (Standard)
51~99: Tachometer Signal (Custom)

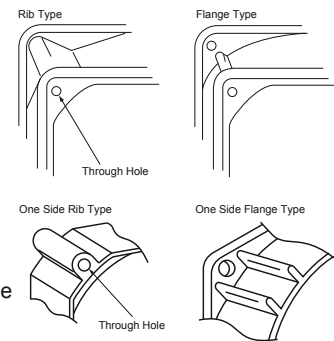

FB Series Part Numbering System

- | | | | | | | | | | |
|--|----|---|----|---|----|---|---|---|---|
| | | | | | | | | | |
| | FB | A | 08 | A | 12 | H | 1 | A | S |
| | ① | ② | ③ | ④ | ⑤ | ⑥ | ⑦ | ⑧ | ⑨ |
- Motor Type
FB: DC Axial
 - Bearing/Motor Type
A: HWB
K: Ball Bearing
L: ES Series
 - Housing Size
04: 40x40mm
06: 60x60mm
08: 80x80mm
09: 92x92mm
12: 120x120mm
 - Housing Thickness
A: 25.5mm
T: 15mm
G: 38mm
F: 20mm
H: 42mm
 - Rated Voltage
12: 12V
24: 24V
 - Speed
L: Low
M: Middle
H: High
V: Variable (Option)
 - Terminal
1: With Leads
□: No Leads
 - Lead Wire
A: Standard 2 Leads
B: Standard 3 Leads
C~: Optional Leads
 - Option
S: Locked Sensor
X: Tacho Sensor
Z: Solid Corner
O: S+Z



General Specifications

Motor Protection:

Auto Restart/Polarity Protection

Insulation Resistance:

10M Ω or over with a DC500V Megger

Dielectric Withstand Voltage: AC 700V 1s

Allowable Ambient Temperature Range:

-10°C ~ +60°C (Operating)

-40°C ~ +60°C (Storage)

(non-condensing environment)

Expected Life

Failure Rate: 10%

25°C 50,000 Hours (B00)

Outline

Units: $\frac{\text{inch}}{\text{mm}}$

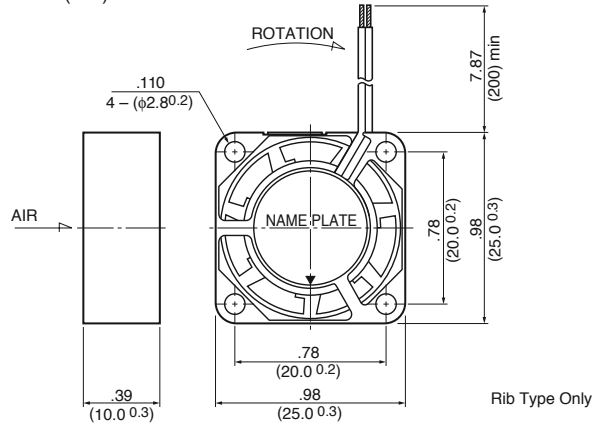

Characteristic Curves

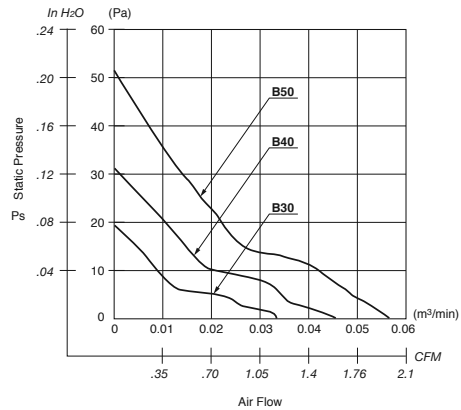

Panel Cut-outs

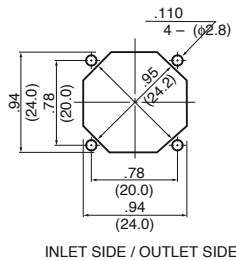

Material

Casing : Plastic (Black) 94V-0

Impeller : Plastic (Black) 94V-0

Bearing : Ball Bearing

Lead Wire: UL1061, AWG26, +Red, -Black

Specifications

MODEL	Product No.	Rated Voltage	Operating Voltage	Current	Input Power	Speed	Max. Air Flow		Max. Static Pressure		Noise	Mass
		(V)	(V)	(A) ^{*1}	(W) ^{*1}	(min ⁻¹) ^{*1}	CFM ^{*1}	(m ³ /min) ^{*1}	in H ₂ O	(Pa) ^{*1}	(dB) ^{*1}	(g)
1004KL-01W-B30-	X00	5	4.5 ~ 5.5	0.065	0.325	7000	1.2	0.034	.078	19.5	20.0	7.5
1004KL-01W-B40-	X00	5	4.5 ~ 5.5	0.085	0.425	9000	1.6	0.046	.126	31.6	22.0	7.5
1004KL-01W-B50-	X00	5	4.5 ~ 5.5	0.125	0.625	11000	2.0	0.057	.20	50.6	25.0	7.5
1004KL-04W-B30-	X00	12	8 ~ 13.8	0.035	0.42	7000	1.2	0.034	.078	19.5	20.0	7.5
1004KL-04W-B40-	X00	12	8 ~ 13.8	0.045	0.54	9000	1.6	0.046	.126	31.6	22.0	7.5
1004KL-04W-B50-	X00	12	8 ~ 13.8	0.060	0.72	11000	2.0	0.057	.20	50.6	25.0	7.5

Rotation: Clockwise

Airflow Outlet: Air Out Over Struts

*1: Average Values in Free Air



General Specifications

Motor Protection:

Auto Restart/Polarity Protection

Insulation Resistance:

10M Ω or over with a DC500V Megger

Dielectric Withstand Voltage: AC 700V 1s

Allowable Ambient Temperature Range:

-10°C ~ +70°C (Operating)

-40°C ~ +70°C (Storage)

(non-condensing environment)

Expected Life

Failure Rate: 10%

25°C 50,000 Hours (B00)

Outline

Units: $\frac{\text{inch}}{\text{mm}}$

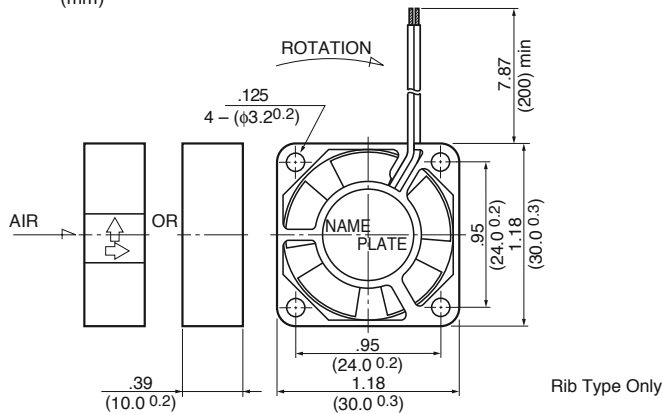

Characteristic Curves

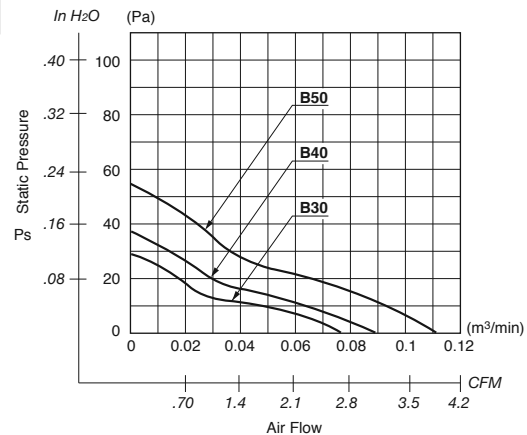

Panel Cut-outs

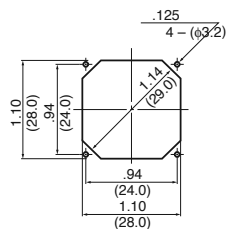

Material

Casing : Plastic (Black) 94V-0

Impeller : Plastic (Black) 94V-0

Bearing : Ball Bearing

Lead Wire : UL1061, AWG26, +Red, -Black

Specifications

MODEL	Product No.	Rated Voltage	Operating Voltage	Current	Input Power	Speed	Max. Air Flow		Max. Static Pressure		Noise	Mass
		(V)	(V)	(A) ^{*1}	(W) ^{*1}	(min ⁻¹) ^{*1}	CFM ^{*1}	(m ³ /min) ^{*1}	in H ₂ O	(Pa) ^{*1}	(dB) ^{*1}	(g)
1204KL-01W-B30-	X00	5	4.5 ~ 5.5	0.10	0.50	7500	2.7	0.078	.116	29.0	21.0	8.5
1204KL-01W-B40-	X00	5	4.5 ~ 5.5	0.14	0.70	9000	3.2	0.091	.148	37.0	23.0	8.5
1204KL-01W-B50-	X00	5	4.5 ~ 5.5	0.18	0.90	10500	3.8	0.110	.216	54.0	27.0	8.5
1204KL-04W-B30-	X00	12	6 ~ 13.8	0.06	0.72	7500	2.7	0.078	.116	29.0	21.0	8.5
1204KL-04W-B40-	X00	12	6 ~ 13.8	0.07	0.84	9000	3.2	0.091	.148	37.0	23.0	8.5
1204KL-04W-B50-	X00	12	6 ~ 13.8	0.08	0.96	10500	3.8	0.110	.216	54.0	27.0	8.5

Rotation: Clockwise

Airflow Outlet: Air Out Over Struts

*1: Average Values in Free Air



General Specifications

Motor Protection:

Auto Restart/Polarity Protection

Insulation Resistance:

10M Ω or over with a DC500V Megger

Dielectric Withstand Voltage: AC 700V 1s

Allowable Ambient Temperature Range:

-10°C ~ +70°C (Operating)

-40°C ~ +70°C (Storage)

(non-condensing environment)

Expected Life

Failure Rate: 10%

25°C 50,000 Hours (B00)

Outline

Units: $\frac{\text{inch}}{\text{mm}}$

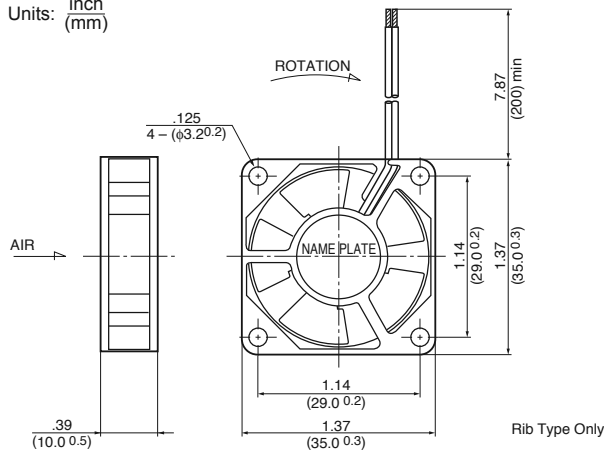

Characteristic Curves

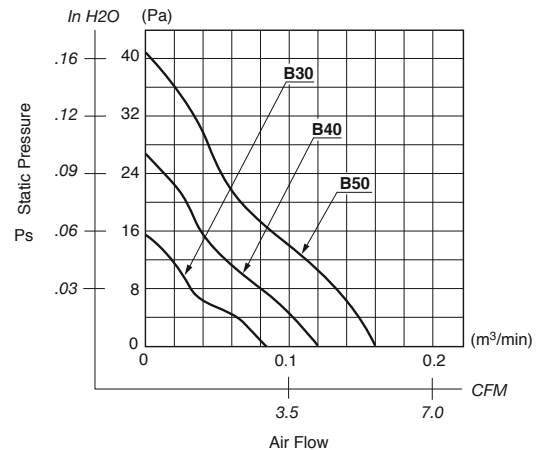

Panel Cut-outs

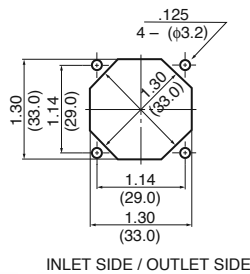

Material

Casing : Plastic (Black) 94V-0

Impeller : Plastic (Black) 94V-0

Bearing : Ball Bearing

Lead Wire : UL1061, AWG26, +Red, -Black

Specifications

MODEL	Product No.	Rated Voltage	Operating Voltage	Current	Input Power	Speed	Max. Air Flow		Max. Static Pressure		Noise	Mass
		(V)	(V)	(A) ^{*1}	(W) ^{*1}	(min ⁻¹) ^{*1}	CFM ^{*1}	(m ³ /min) ^{*1}	in H ₂ O	(Pa) ^{*1}	(dB) ^{*1}	(g)
1404KL-01W-B30-	X00	5	4.5 ~ 5.5	0.08	0.40	5000	3.0	0.086	.06	15.5	19.0	12
1404KL-01W-B40-	X00	5	4.5 ~ 5.5	0.17	0.85	7000	4.2	0.120	.10	26.8	22.0	12
1404KL-01W-B50-	X00	5	4.5 ~ 5.5	0.21	1.05	9000	5.6	0.160	.16	41.0	27.0	12
1404KL-04W-B30-	X00	12	8 ~ 13.8	0.04	0.48	5000	3.0	0.086	.06	15.5	19.0	12
1404KL-04W-B40-	X00	12	8 ~ 13.8	0.07	0.84	7000	4.2	0.120	.10	26.8	22.0	12
1404KL-04W-B50-	X00	12	8 ~ 13.8	0.08	0.96	9000	5.6	0.160	.16	41.0	27.0	12

Rotation: Clockwise

Airflow Outlet: Air Out Over Struts

*1: Average Values in Free Air



General Specifications

Motor Protection:

Auto Restart/Polarity Protection

Insulation Resistance:

10M Ω or over with a DC500V Megger

Dielectric Withstand Voltage: AC 700V 1s

Allowable Ambient Temperature Range:

-10°C ~ +70°C (Operating)

-40°C ~ +70°C (Storage)

(non-condensing environment)

Expected Life

Failure Rate: 10%

25°C 60,000 Hours (B00)

Outline

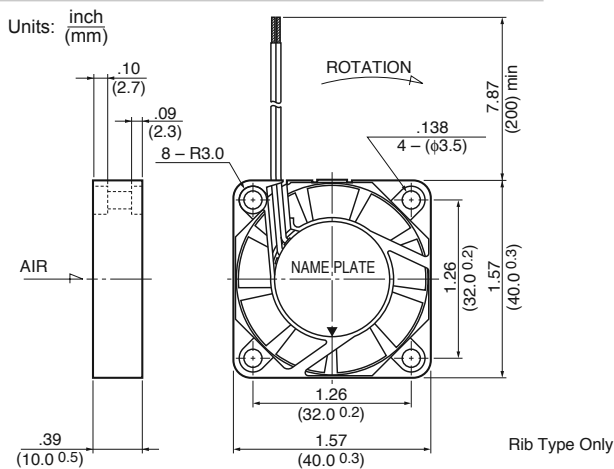

Characteristic Curves

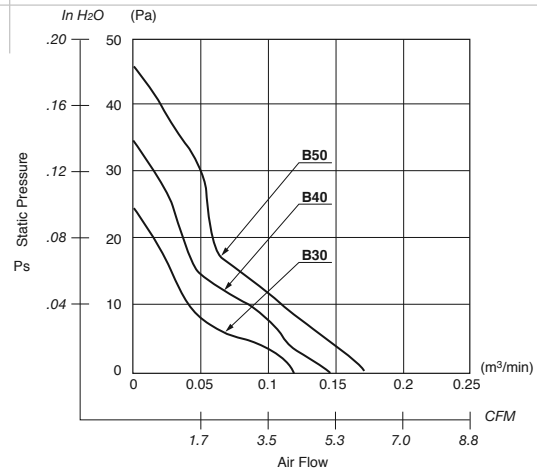

Panel Cut-outs

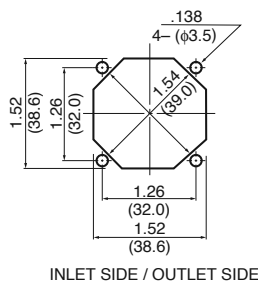

Material

Casing : Plastic (Black) 94V-0

Impeller : Plastic (Black) 94V-0

Bearing : Ball Bearing

Lead Wire : UL1061, AWG26, +Red, -Black

Specifications

MODEL	Product No.	Rated Voltage	Operating Voltage	Current	Input Power	Speed	Max. Air Flow		Max. Static Pressure		Noise	Mass
		(V)	(V)	(A) ^{*1}	(W) ^{*1}	(min ⁻¹) ^{*1}	CFM ^{*1}	(m ³ /min) ^{*1}	in H ₂ O	(Pa) ^{*1}	(dB) ^{*1}	(g)
1604KL-01W-B30-	X00	5	4.5 ~ 5.5	0.075	0.375	4500	4.2	0.12	.096	24.0	22.0	15
1604KL-01W-B40-	X00	5	4.5 ~ 5.5	0.120	0.600	5500	5.3	0.15	.136	34.0	25.0	15
1604KL-01W-B50-	X00	5	4.5 ~ 5.5	0.155	0.775	6500	6.0	0.17	.184	46.0	29.0	15
1604KL-04W-B30-	X00	12	10.2 ~ 13.8	0.062	0.744	4500	4.2	0.12	.096	24.0	22.0	15
1604KL-04W-B40-	X00	12	10.2 ~ 13.8	0.073	0.876	5500	5.3	0.15	.136	34.0	25.0	15
1604KL-04W-B50-	X00	12	10.2 ~ 13.8	0.073	0.876	6500	6.0	0.17	.184	46.0	29.0	15

Rotation: Clockwise

Airflow Outlet: Air Out Over Struts

*1: Average Values in Free Air



General Specifications

Motor Protection:

Auto Restart/Polarity Protection

Insulation Resistance:

10M Ω or over with a DC500V Megger

Dielectric Withstand Voltage: AC 700V 1s

Allowable Ambient Temperature Range:

-10°C ~ +70°C (Operating)

-40°C ~ +70°C (Storage)

(non-condensing environment)

Expected Life

Failure Rate: 10%

25°C 50,000 Hours (L00)

Outline

Units: $\frac{\text{inch}}{\text{mm}}$

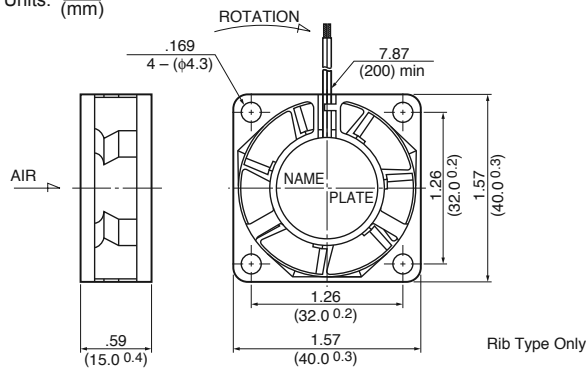

Characteristic Curves

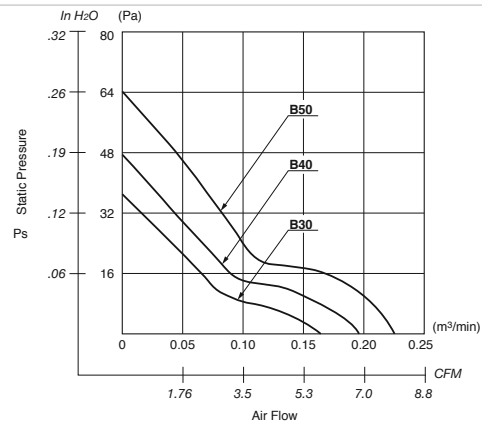

Panel Cut-outs

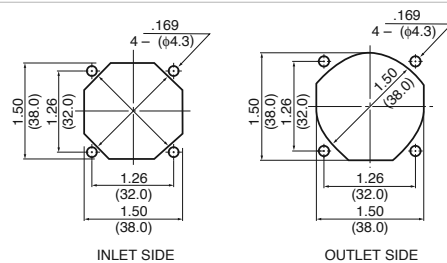

Material

Casing : Plastic (Black) 94V-0

Impeller : Plastic (Black) 94V-0

Bearing : Ball Bearing

Lead Wire : UL1061, AWG26, +Red, -Black

Specifications

MODEL	Product No.	Rated Voltage	Operating Voltage	Current	Input Power	Speed	Max. Air Flow		Max. Static Pressure		Noise	Mass
		(V)	(V)	(A) ^{*1}	(W) ^{*1}	(min ⁻¹) ^{*1}	CFM ^{*1}	(m ³ /min) ^{*1}	in H ₂ O	(Pa) ^{*1}	(dB) ^{*1}	(g)
1606KL-01W-B30-	X00	5	4.5 ~ 5.5	0.120	0.600	6000	6.0	0.17	.145	36.3	28.0	20
1606KL-01W-B40-	X00	5	4.5 ~ 5.5	0.150	0.750	7000	7.0	0.20	.188	47.1	31.0	20
1606KL-01W-B50-	X00	5	4.5 ~ 5.5	0.240	1.200	8000	8.1	0.23	.250	62.8	34.0	20
1606KL-04W-B30-	X00	12	10.2 ~ 13.8	0.067	0.804	6000	6.0	0.17	.145	36.3	28.0	20
1606KL-04W-B40-	X00	12	10.2 ~ 13.8	0.075	0.900	7000	7.0	0.20	.188	47.1	31.0	20
1606KL-04W-B50-	X00	12	10.2 ~ 13.8	0.085	1.020	8000	8.1	0.23	.250	62.8	34.0	20
1606KL-05W-B30-	X00	24	22.0 ~ 25.2	0.045	1.080	6000	6.0	0.17	.145	36.3	28.0	20
1606KL-05W-B40-	X00	24	22.0 ~ 25.2	0.054	1.296	7000	7.0	0.20	.188	47.1	31.0	20
1606KL-05W-B50-	X00	24	22.0 ~ 25.2	0.062	1.488	8000	8.1	0.23	.250	62.8	34.0	20

Rotation: Clockwise

Airflow Outlet: Air Out Over Struts

*1: Average Values in Free Air



General Specifications

Motor Protection:

Auto Restart/Polarity Protection

Insulation Resistance:

10M Ω or over with a DC500V Megger

Dielectric Withstand Voltage: AC 700V 1s

Allowable Ambient Temperature Range:

-10°C ~ +70°C (Operating)

-40°C ~ +70°C (Storage)

(non-condensing environment)

Expected Life

Failure Rate: 10%

25°C 80,000 Hours

Outline

Units: $\frac{\text{inch}}{\text{(mm)}}$

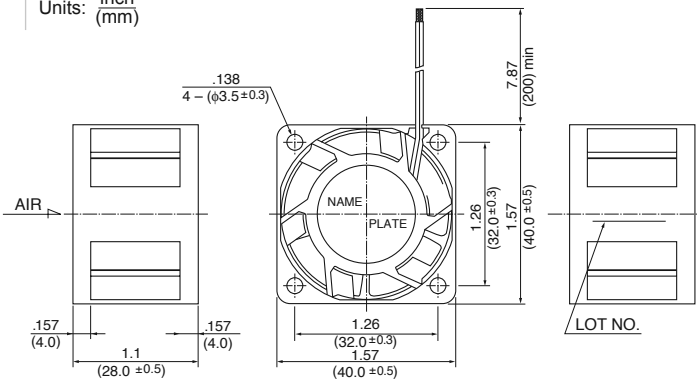

Characteristic Curves

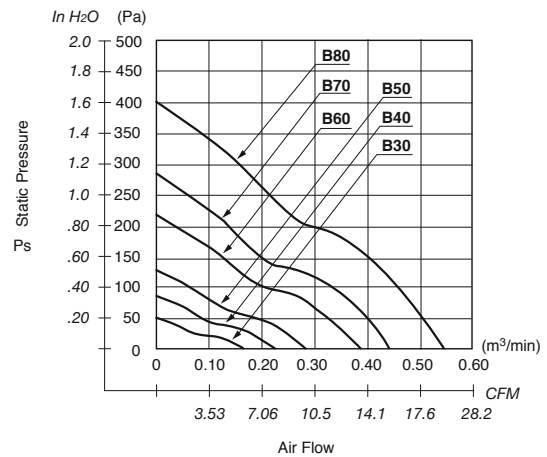

Panel Cut-outs

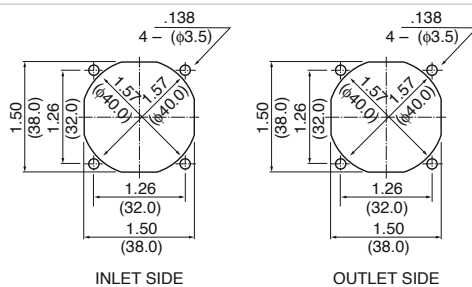

Material

Casing : Plastic (Black) 94V-0

Impeller : Plastic (Black) 94V-0

Bearing : Ball Bearing

Lead Wire : UL1061, AWG28, +Red, -Black

Specifications

MODEL	Product No.	Rated Voltage	Operating Voltage	Current	Input Power	Speed	Max. Air Flow		Max. Static Pressure		Noise	Mass
		(V)	(V)				CFM ^{*1}	(m ³ /min) ^{*1}	in H ₂ O	(Pa) ^{*1}		
1611RL-04W-B30-	X00	12	7.0 ~ 13.2	0.07	0.84	6000	6.0	0.17	.18	46.0	30.0	48
1611RL-04W-B40-	X00	12	7.0 ~ 13.2	0.10	1.20	8000	8.4	0.24	.33	84.5	37.5	48
1611RL-04W-B50-	X00	12	7.0 ~ 13.2	0.17	2.04	10000	10.5	0.30	.52	130.0	43.5	48
1611RL-04W-B60-	X00	12	7.0 ~ 13.2	0.27	3.24	13000	13.7	0.39	.87	217.5	49.5	48
1611RL-04W-B70-	X00	12	7.0 ~ 13.2	0.36	4.32	15000	15.8	0.45	1.13	283.5	54.0	48
1611RL-04W-B80-	X00	12	7.0 ~ 13.2	0.62	7.44	18000	19.4	0.55	1.61	402.0	60.0	48

Rotation: Clockwise

Airflow Outlet: Air Out Over Struts

*1: Average Values in Free Air

General Specifications

Motor Protection:

Auto Restart/Polarity Protection

Insulation Resistance:

10M Ω or over with a DC500V Megger

Dielectric Withstand Voltage: AC 700V 1s

Allowable Ambient Temperature Range:

-10°C ~ +70°C (Operating)

-40°C ~ +70°C (Storage)

(non-condensing environment)

Expected Life

Failure Rate: 10%

25°C 50,000 Hours (L00)

Characteristic Curves

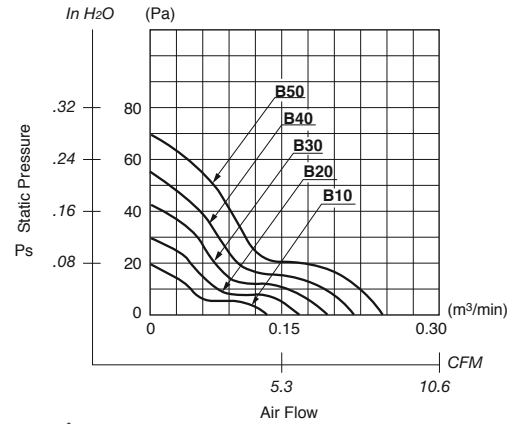

Outline

Units: inch (mm)

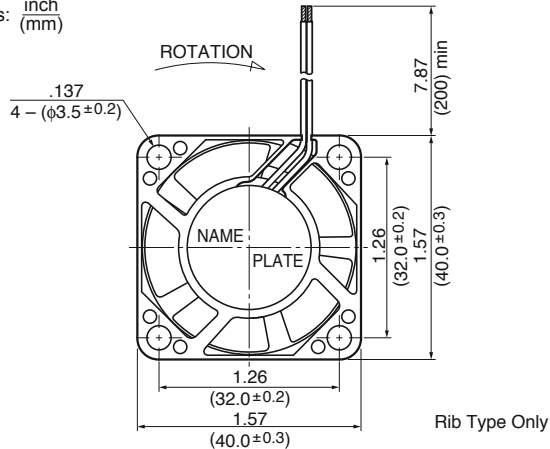

Rib Type Only

Panel Cut-outs

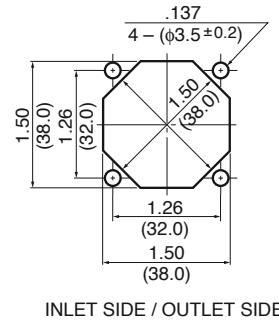

INLET SIDE / OUTLET SIDE

Material

Casing : Plastic (Black) 94V-0

Impeller : Plastic (Black) 94V-0

Bearing : Ball Bearing

Lead Wire: UL1061, AWG26, +Red, -Black

Specifications

MODEL	Product No.	Rated Voltage	Operating Voltage	Current	Input Power	Speed	Max. Air Flow		Max. Static Pressure		Noise	Mass
		(V)	(V)	(A) ^{*1}	(W) ^{*1}	(min ⁻¹) ^{*1}	CFM ^{*1}	(m ³ /min) ^{*1}	in H ₂ O	(Pa) ^{*1}	(dB) ^{*1}	(g)
1608KL-01W-B10-	X00	5	4.5 ~ 5.5	0.07	0.35	4500	4.9	0.14	.08	20.0	20.0	25
1608KL-01W-B20-	X00	5	4.5 ~ 5.5	0.12	0.60	5500	6.0	0.17	.12	30.1	22.5	25
1608KL-01W-B30-	X00	5	4.5 ~ 5.5	0.17	0.85	6500	7.4	0.21	.17	42.2	25.5	25
1608KL-01W-B40-	X00	5	4.5 ~ 5.5	0.27	1.35	7500	8.4	0.24	.21	54.2	29.0	25
1608KL-01W-B50-	X00	5	4.5 ~ 5.5	0.38	1.90	8500	9.5	0.27	.28	69.4	33.0	25
1608KL-04W-B10-	X00	12	10.2 ~ 13.8	0.04	0.48	4500	4.9	0.14	.08	20.0	20.0	25
1608KL-04W-B20-	X00	12	10.2 ~ 13.8	0.06	0.72	5500	6.0	0.17	.12	30.1	22.5	25
1608KL-04W-B30-	X00	12	10.2 ~ 13.8	0.07	0.84	6500	7.4	0.21	.17	42.2	25.5	25
1608KL-04W-B40-	X00	12	10.2 ~ 13.8	0.09	1.08	7500	8.4	0.24	.21	54.2	29.0	25
1608KL-04W-B50-	X00	12	10.2 ~ 13.8	0.11	1.32	8500	9.5	0.27	.28	69.4	33.0	25
1608KL-05W-B10-	X00	24	20.0 ~ 25.2	0.04	0.96	4500	4.9	0.14	.08	20.0	20.0	25
1608KL-05W-B20-	X00	24	20.0 ~ 25.2	0.05	1.20	5500	6.0	0.17	.12	30.1	22.5	25
1608KL-05W-B30-	X00	24	20.0 ~ 25.2	0.06	1.44	6500	7.4	0.21	.17	42.2	25.5	25
1608KL-05W-B40-	X00	24	20.0 ~ 25.2	0.07	1.68	7500	8.4	0.24	.21	54.2	29.0	25
1608KL-05W-B50-	X00	24	20.0 ~ 25.2	0.08	1.92	8500	9.5	0.27	.28	69.4	33.0	25

Rotation: Clockwise

Airflow Outlet: Air Out Over Struts

*1: Average Values in Free Air



General Specifications

Motor Protection:

Auto Restart/Polarity Protection

Insulation Resistance:

10M Ω or over with a DC500V Megger

Dielectric Withstand Voltage: AC 700V 1s

Allowable Ambient Temperature Range:

-10°C ~ +70°C (Operating)

-40°C ~ +70°C (Storage)

(non-condensing environment)

Expected Life

Failure Rate: 10%

25°C 60,000 Hours (B00)

Outline

Units: $\frac{\text{inch}}{\text{mm}}$

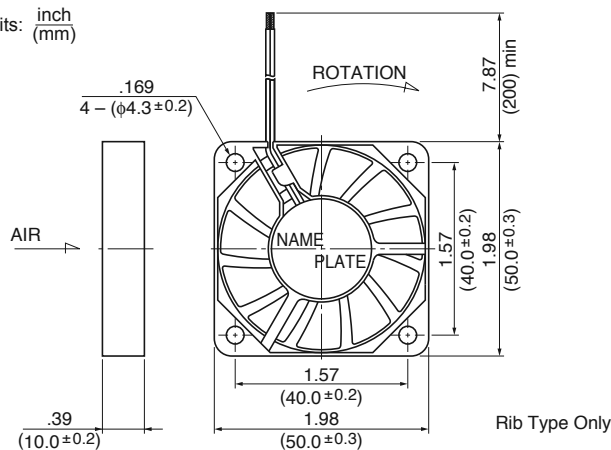

Rib Type Only

Characteristic Curves

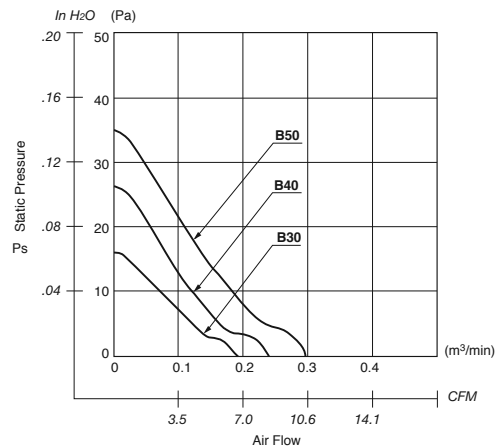

Panel Cut-outs

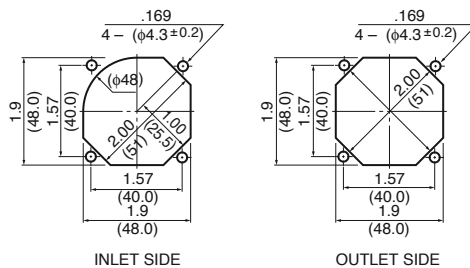

INLET SIDE

OUTLET SIDE

Material

Casing : Plastic (Black) 94V-0

Impeller : Plastic (Black) 94V-0

Bearing : Ball Bearing

Lead Wire : UL1061, AWG26, +Red, -Black

Specifications

MODEL	Product No.	Rated Voltage	Operating Voltage	Current	Input Power	Speed	Max. Air Flow		Max. Static Pressure		Noise	Mass
		(V)	(V)	(A) ^{*1}	(W) ^{*1}	(min ⁻¹) ^{*1}	CFM ^{*1}	(m ³ /min) ^{*1}	in H ₂ O	(Pa) ^{*1}	(dB) ^{*1}	(g)
2004KL-01W-B30-	X00	5	4.5 ~ 6.0	0.10	0.50	3500	6.4	0.18	.06	16.0	23.0	20
2004KL-01W-B40-	X00	5	4.5 ~ 6.0	0.16	0.80	4500	8.1	0.23	.10	26.0	28.5	20
2004KL-01W-B50-	X00	5	4.5 ~ 6.0	0.30	1.50	5500	10.2	0.29	.14	35.0	34.0	20
2004KL-04W-B30-	X00	12	10.2 ~ 13.8	0.04	0.48	3500	6.4	0.18	.06	16.0	23.0	20
2004KL-04W-B40-	X00	12	10.2 ~ 13.8	0.07	0.84	4500	8.1	0.23	.10	26.0	28.5	20
2004KL-04W-B50-	X00	12	10.2 ~ 13.8	0.10	1.20	5500	10.2	0.29	.14	35.0	34.0	20

Rotation: Clockwise

Airflow Outlet: Air Out Over Struts

*1: Average Values in Free Air



General Specifications

Motor Protection:

Auto Restart/Polarity Protection

Insulation Resistance:

10M Ω or over with a DC500V Megger

Dielectric Withstand Voltage: AC 700V 1s

Allowable Ambient Temperature Range:

-10°C ~ +60°C (Operating)

-40°C ~ +70°C (Storage)

(non-condensing environment)

Expected Life

Failure Rate: 10%

25°C 50,000 Hours (L00)

Outline

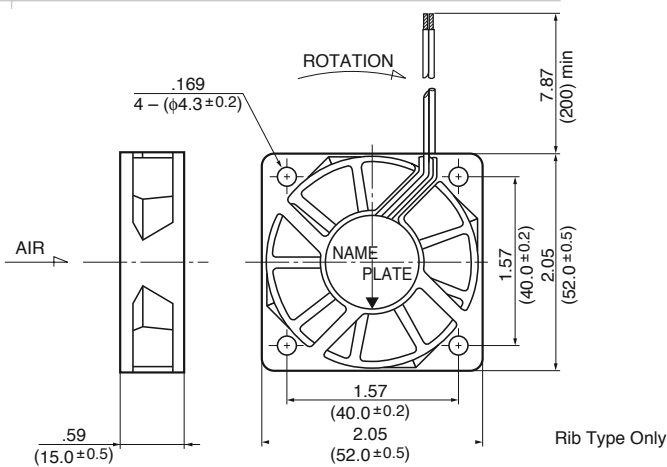

Characteristic Curves

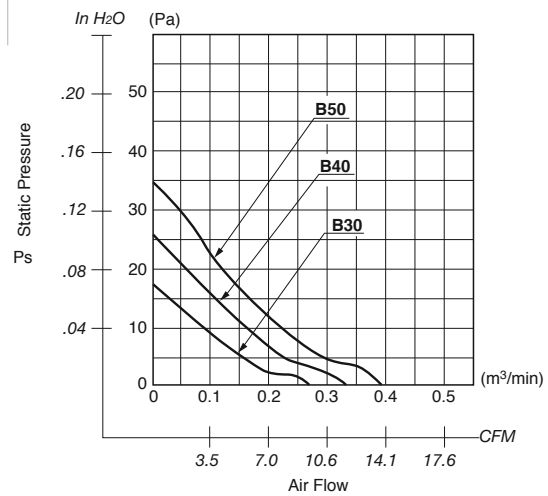

Panel Cut-outs

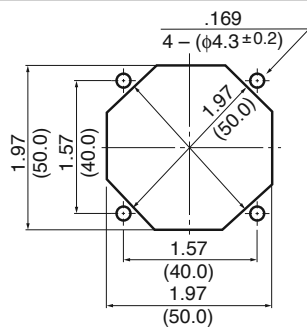

INLET SIDE / OUTLET SIDE

Material

Casing : Plastic (Black) 94V-0

Impeller : Plastic (Black) 94V-0

Bearing : Ball Bearing

Lead Wire : UL1061, AWG26, +Red, -Black

Specifications

MODEL	Product No.	Rated Voltage	Operating Voltage	Current	Input Power	Speed	Max. Air Flow		Max. Static Pressure		Noise	Mass
		(V)	(V)	(A) ^{*1}	(W) ^{*1}	(min ⁻¹) ^{*1}	CFM ^{*1}	(m ³ /min) ^{*1}	in H ₂ O	(Pa) ^{*1}	(dB) ^{*1}	(g)
2106KL-04W-B30-	X00	12	10.2 ~ 13.0	0.07	0.84	3500	9.9	0.28	.07	18.0	21.0	25
2106KL-04W-B40-	X00	12	10.2 ~ 13.0	0.09	1.08	4200	12.0	0.34	.10	26.0	25.5	25
2106KL-04W-B50-	X00	12	10.2 ~ 13.0	0.13	1.56	4900	14.1	0.40	.14	35.0	30.0	25

Rotation: Clockwise

Airflow Outlet: Air Out Over Struts

*1: Average Values in Free Air



General Specifications

Motor Protection:

Auto Restart/Polarity Protection

Insulation Resistance:

10M Ω or over with a DC500V Megger

Dielectric Withstand Voltage: AC 700V 1s

Allowable Ambient Temperature Range:

B50 Class: -10°C ~ +60°C (Operating)

B30 Class: -10°C ~ +70°C (Operating)

All Classes: -40°C ~ +70°C (Storage)

(non-condensing environment)

Expected Life

Failure Rate: 10%

25°C 60,000 Hours (B00)

Outline

Units: $\frac{\text{inch}}{\text{mm}}$

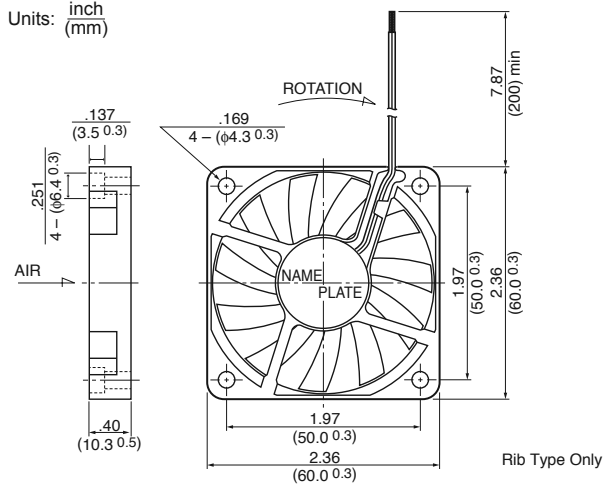

Characteristic Curves

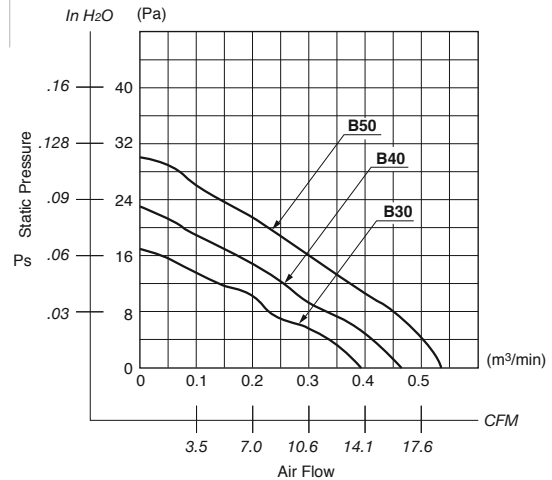

Panel Cut-outs

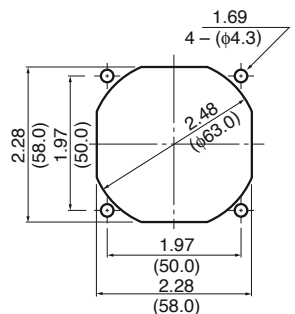

Material

Casing : Plastic (Black) 94V-0

Impeller : Plastic (Black) 94V-0

Bearing : Ball Bearing

Lead Wire : UL1061, AWG26, +Red, -Black

Specifications

MODEL	Product No.	Rated Voltage	Operating Voltage	Current	Input Power	Speed	Max. Air Flow		Max. Static Pressure		Noise	Mass
		(V)	(V)	(A) ^{*1}	(W) ^{*1}	(min ⁻¹) ^{*1}	CFM ^{*1}	(m ³ /min) ^{*1}	in H ₂ O	(Pa) ^{*1}	(dB) ^{*1}	(g)
** 2404KL-04W-B30-	X00	12	10.2 ~ 13.8	0.10	1.20	3600	13.7	0.39	.07	16.7	29.0	25
** 2404KL-04W-B40-	X00	12	10.2 ~ 13.8	0.20	2.40	4200	16.2	0.46	.09	23.0	33.0	25
2404KL-04W-B50-	X00	12	10.2 ~ 13.8	0.27	3.24	4800	19.0	0.54	.12	30.1	36.0	25

Rotation: Clockwise

Airflow Outlet: Air Out Over Struts

*1: Average Values in Free Air

** Contact NMB for availability



General Specifications

Motor Protection:

Auto Restart/Polarity Protection

Insulation Resistance:

10M Ω or over with a DC500V Megger

Dielectric Withstand Voltage: AC 700V 1s

Allowable Ambient Temperature Range:

-10°C ~ +60°C (Operating)

-40°C ~ +60°C (Storage)

(non-condensing environment)

Expected Life

Failure Rate: 10%

25°C 70,000 Hours (L00)

Characteristic Curves

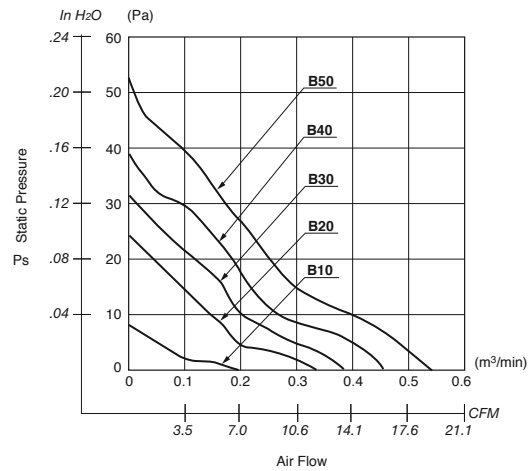

Outline

Units: inch (mm)

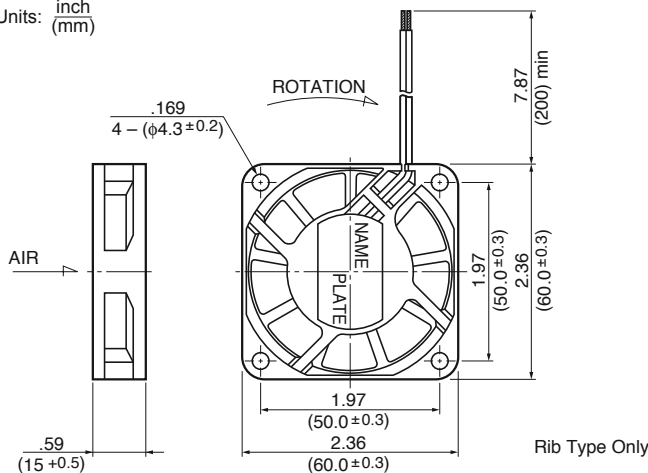

Panel Cut-outs

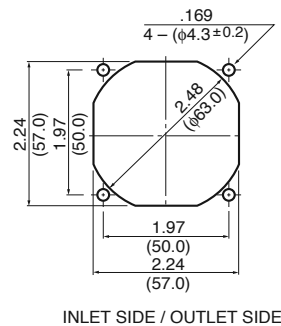

Material

Casing : Plastic (Black) 94V-0

Impeller : Plastic (Black) 94V-0

Bearing : Ball Bearing

Lead Wire: UL1007, AWG26, +Red, -Black

Specifications

MODEL	Product No.	Rated Voltage	Operating Voltage	Current	Input Power	Speed	Max. Air Flow		Max. Static Pressure		Noise	Mass
		(V)	(V)	(A) ^{*1}	(W) ^{*1}	(min ⁻¹) ^{*1}	CFM ^{*1}	(m ³ /min) ^{*1}	in H ₂ O	(Pa) ^{*1}	(dB) ^{*1}	(g)
2406KL-04W-B10-	X00	12	7.0 ~ 13.8	0.04	0.48	1800	6.7	0.19	.03	8.5	19.0	45
2406KL-04W-B20-	X00	12	6.0 ~ 13.8	0.07	0.84	3100	11.6	0.33	.09	23.4	25.0	45
2406KL-04W-B30-	X00	12	6.0 ~ 13.8	0.09	1.08	3600	14.1	0.40	.13	31.3	28.0	45
2406KL-04W-B40-	X00	12	6.0 ~ 13.8	0.13	1.56	4100	15.9	0.45	.16	39.7	31.0	45
2406KL-04W-B50-	X00	12	6.0 ~ 13.8	0.16	1.92	4600	18.3	0.52	.20	51.2	34.0	45
2406KL-05W-B10-	X00	24	18.5 ~ 27.6	0.04	0.96	1800	6.7	0.19	.03	8.5	19.0	45
2406KL-05W-B20-	X00	24	12.0 ~ 27.6	0.06	1.44	3100	11.6	0.33	.09	23.4	25.0	45
2406KL-05W-B30-	X00	24	12.0 ~ 27.6	0.06	1.44	3600	14.1	0.40	.13	31.3	28.0	45
2406KL-05W-B40-	X00	24	10.0 ~ 27.6	0.07	1.68	4100	15.9	0.45	.16	39.7	31.0	45
2406KL-05W-B50-	X00	24	10.0 ~ 27.6	0.10	2.40	4600	18.3	0.52	.20	51.2	34.0	45

Rotation: Clockwise

Airflow Outlet: Air Out Over Struts

*1: Average Values in Free Air



General Specifications

Motor Protection:

Auto Restart/Polarity Protection

Insulation Resistance:

10M Ω or over with a DC500V Megger

Dielectric Withstand Voltage: AC 700V 1s

Allowable Ambient Temperature Range:

-10°C ~ +70°C (Operating)

-40°C ~ +70°C (Storage)

(non-condensing environment)

Expected Life

Failure Rate: 10%

25°C 60,000 Hours (L00, P00)

Characteristic Curves

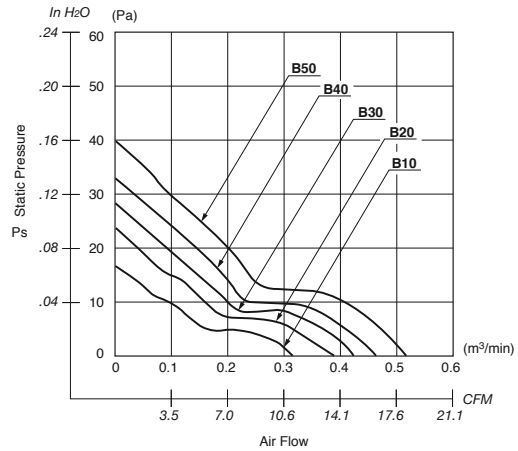

Outline

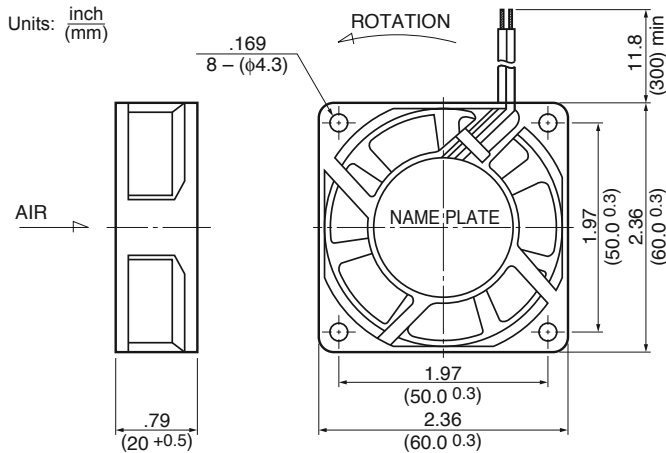

Panel Cut-outs

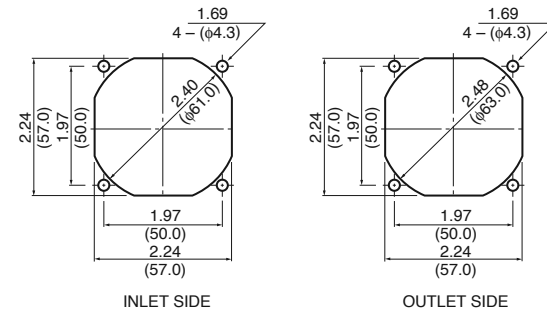

Material

Casing : Plastic (Black) 94V-0

Impeller : Plastic (Black) 94V-0

Bearing : Ball Bearing

Lead Wire : UL1007, AWG24, +Red, -Black

Specifications

MODEL	Product No.	Rated Voltage	Operating Voltage	Current	Input Power	Speed	Max. Air Flow		Max. Static Pressure		Noise	Mass
		(V)	(V)	(A) ^{*1}	(W) ^{*1}	(min ⁻¹) ^{*1}	CFM ^{*1}	(m ³ /min) ^{*1}	in H ₂ O	(Pa) ^{*1}	(dB) ^{*1}	(g)
2408NL-04W-B10-	X00	12	6.0 ~ 13.8	0.05	0.60	2800	10.9	0.31	.07	16.7	22.5	65
2408NL-04W-B20-	X00	12	6.0 ~ 13.8	0.07	0.84	3200	13.0	0.37	.09	23.5	25.5	65
2408NL-04W-B30-	X00	12	6.0 ~ 13.8	0.08	0.96	3600	14.8	0.42	.11	28.7	27.0	65
2408NL-04W-B40-	X00	12	6.0 ~ 13.8	0.09	1.08	4000	15.9	0.45	.13	33.2	29.0	65
2408NL-04W-B50-	X00	12	6.0 ~ 13.8	0.11	1.32	4400	17.6	0.50	.16	40.5	31.5	65
2408NL-05W-B10-	X00	24	15.0 ~ 27.6	0.04	0.96	2800	10.9	0.31	.07	16.7	22.5	65
2408NL-05W-B20-	X00	24	15.0 ~ 27.6	0.04	0.96	3200	13.0	0.37	.09	23.5	25.5	65
2408NL-05W-B30-	X00	24	15.0 ~ 27.6	0.045	1.08	3600	14.8	0.42	.11	28.7	27.0	65
2408NL-05W-B40-	X00	24	15.0 ~ 27.6	0.05	1.20	4000	15.9	0.45	.13	33.2	29.0	65
2408NL-05W-B50-	X00	24	15.0 ~ 27.6	0.055	1.32	4400	17.6	0.50	.16	40.5	31.5	65

Rotation: Clockwise

Airflow Outlet: Air Out Over Struts

*1: Average Values in Free Air



General Specifications

Motor Protection:

Auto Restart/Polarity Protection

Insulation Resistance:

10M Ω or over with a DC500V Megger

Dielectric Withstand Voltage: AC 700V 1s

Allowable Ambient Temperature Range:

B80: -10°C ~ +60°C (Operating)

B10 ~ B70: -10°C ~ +70°C (Operating)

All Class: -40°C ~ +70°C (Storage)
(non-condensing environment)

Expected Life

Failure Rate: 10%

25°C 100,000 Hours (B00, E00)

25°C 70,000 Hours (G00, D00)

Characteristic Curves

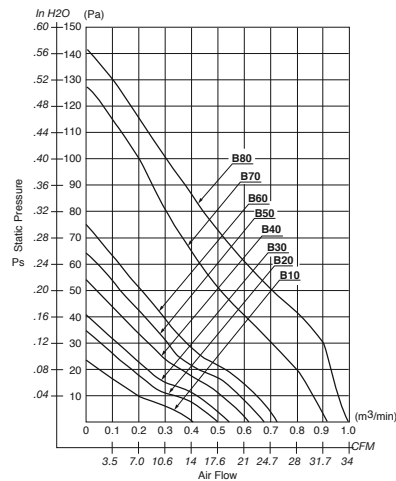

Outline

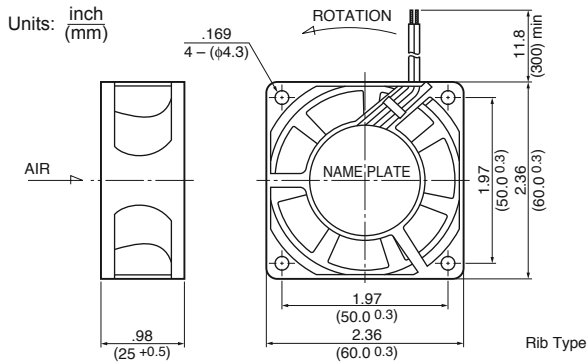

Panel Cut-outs

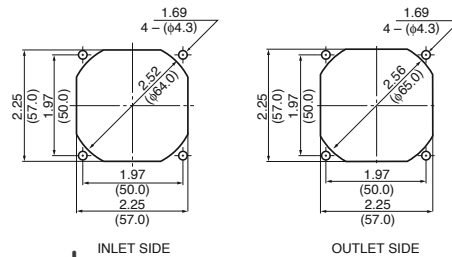

Material

Casing : Plastic (Black) 94V-0

Impeller : Plastic (Black) 94V-0

Bearing : Ball Bearing

Lead Wire: UL1007, AWG24, +Red, -Black

Specifications

MODEL	Product No.	Rated Voltage	Operating Voltage	Current	Input Power	Speed	Max. Air Flow		Max. Static Pressure		Noise	Mass
		(V)	(V)	(A) ^{*1}	(W) ^{*1}	(min ⁻¹) ^{*1}	CFM ^{*1}	(m ³ /min) ^{*1}	in H ₂ O	(Pa) ^{*1}	(dB) ^{*1}	(g)
2410ML-04W-B10	X00	12	6.0 ~ 13.8	0.07	0.90	2950	13.7	0.39	.08	20.6	23.0	65
2410ML-04W-B20	X00	12	6.0 ~ 13.8	0.12	1.44	3600	16.9	0.48	.13	31.9	28.0	65
2410ML-04W-B30	X00	12	6.0 ~ 13.8	0.12	1.44	4000	19.0	0.54	.16	40.2	31.0	65
2410ML-04W-B40	X00	12	6.0 ~ 13.8	0.17	2.04	4550	21.5	0.61	.20	51.9	33.5	65
2410ML-04W-B50	X00	12	6.0 ~ 13.8	0.20	2.40	4900	23.3	0.66	.25	62.2	35.0	65
2410ML-04W-B60	X00	12	6.0 ~ 13.8	0.30	3.60	5300	25.0	0.71	.29	73.0	36.0	65
** 2410ML-04W-B70	X00	12	6.0 ~ 13.8	0.44	5.28	6800	33.1	0.94	.50	125	45.0	65
2410ML-04W-B80	X00	12	6.0 ~ 13.2	0.52	6.20	7800	37.0	1.05	.57	142.5	46.0	65
** 2410ML-05W-B10	X00	24	10.0 ~ 27.6	0.06	1.44	2950	13.7	0.39	.08	20.6	23.0	65
2410ML-05W-B20	X00	24	10.0 ~ 27.6	0.07	1.68	3600	16.9	0.48	.13	31.9	28.0	65
2410ML-05W-B30	X00	24	10.0 ~ 27.6	0.06	1.44	4000	19.0	0.54	.16	40.2	31.0	65
2410ML-05W-B40	X00	24	10.0 ~ 27.6	0.09	2.16	4550	21.5	0.61	.20	51.9	33.5	65
2410ML-05W-B50	X00	24	10.0 ~ 27.6	0.10	2.40	4900	23.3	0.66	.25	62.2	35.0	65
2410ML-05W-B60	X00	24	10.0 ~ 27.6	0.13	3.12	5300	25.0	0.71	.29	73.0	36.0	65
2410ML-05W-B70	X00	24	10.0 ~ 25.2	0.19	4.56	6800	33.1	0.94	.50	125	45.0	65
2410ML-05W-B80	X00	24	10.0 ~ 26.4	0.26	6.24	7350	37.0	1.05	.57	143	50.0	65

Rotation: Clockwise

Airflow Outlet: Air Out Over Struts

*1: Average Values in Free Air

** Contact NMB for availability



General Specifications

Motor Protection:

Auto Restart/Polarity Protection

Insulation Resistance:

10M Ω or over with a DC500V Megger

Dielectric Withstand Voltage: AC 700V 1s

Allowable Ambient Temperature Range:

-10°C ~ +70°C (Operating)

-40°C ~ +70°C (Storage)

(non-condensing environment)

Expected Life

Failure Rate: 10%

25°C 60,000 Hours (X00)

Outline

Units: $\frac{\text{inch}}{\text{mm}}$

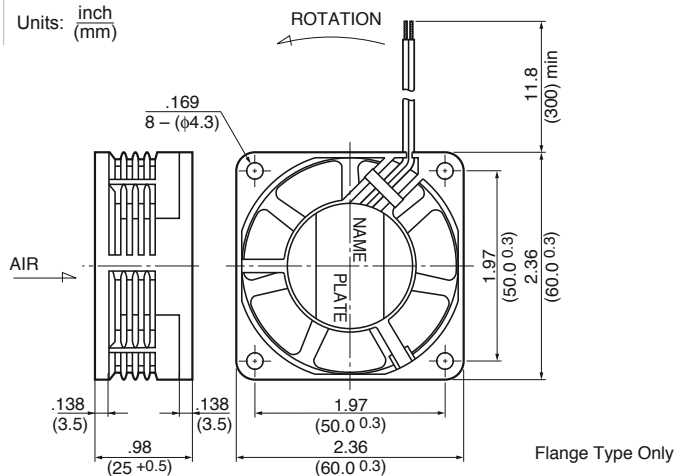

Characteristic Curves

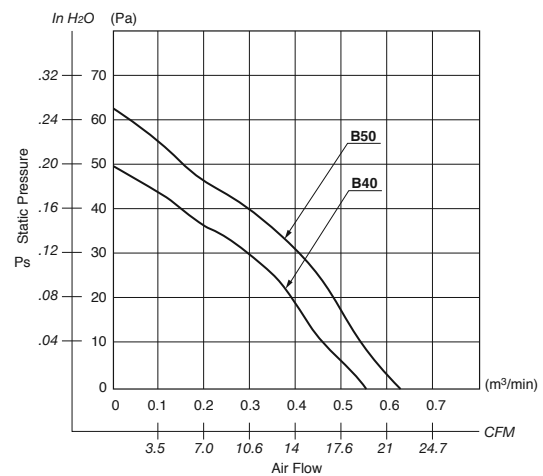

Panel Cut-outs

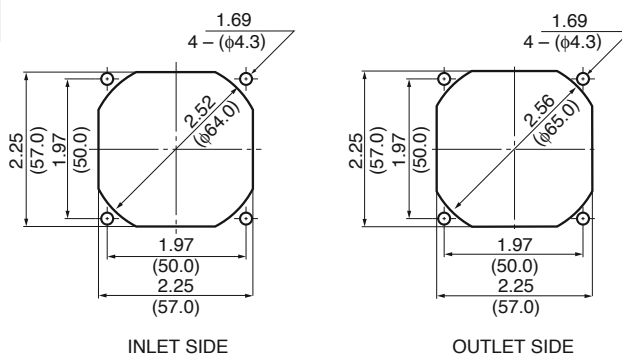

Material

Casing : Plastic (Black) 94V-0

Impeller : Plastic (Black) 94V-0

Bearing : Ball Bearing

Lead Wire : UL1007, AWG24, +Red, -Black

Specifications

MODEL	Product No.	Rated Voltage	Operating Voltage	Current	Input Power	Speed	Max. Air Flow		Max. Static Pressure		Noise	Mass
		(V)	(V)	(A) ^{*1}	(W) ^{*1}	(min ⁻¹) ^{*1}	CFM ^{*1}	(m ³ /min) ^{*1}	in H ₂ O	(Pa) ^{*1}	(dB) ^{*1}	(g)
2410ML-04W-B40-	X00	12	6.0 ~ 13.8	0.16	1.92	4300	19.7	0.56	.19	48.3	31.0	65
2410ML-04W-B50-	X00	12	6.0 ~ 13.8	0.19	2.28	4700	22.2	0.63	.25	62.5	33.0	65

Rotation: Clockwise

Airflow Outlet: Air Out Over Struts

*1: Average Values in Free Air



General Specifications

Motor Protection:

Auto Restart/Polarity Protection

Insulation Resistance:

10M Ω or over with a DC500V Megger

Dielectric Withstand Voltage: AC 700V 1s

Allowable Ambient Temperature Range:

-10°C ~ +60°C (Operating)

-40°C ~ +70°C (Storage)

(non-condensing environment)

Expected Life

Failure Rate: 10%

25°C 80,000 Hours (E00)

Outline

Units: $\frac{\text{inch}}{\text{mm}}$

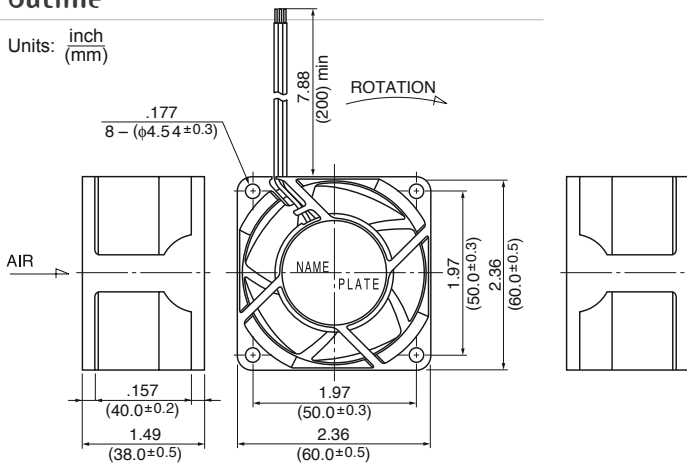

Characteristic Curves

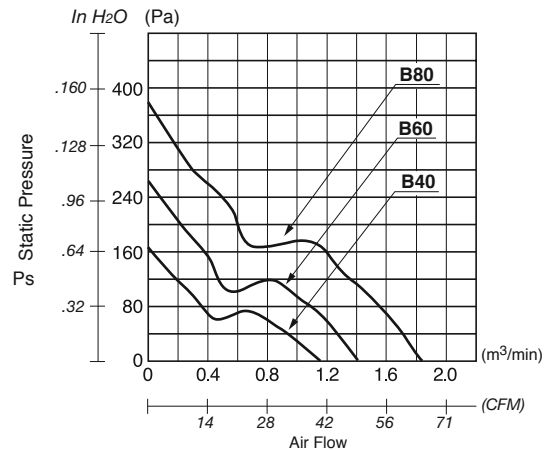

Panel Cut-outs

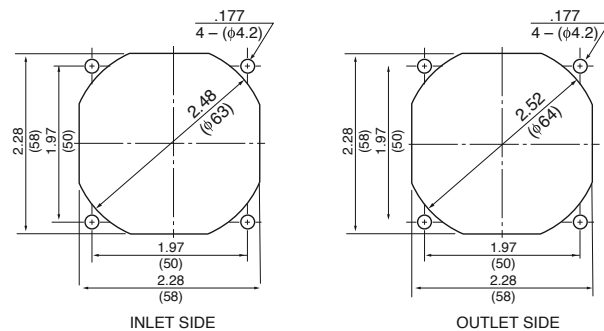

Material

Casing : Plastic (Black) 94V-0

Impeller : Plastic (Black) 94V-0

Bearing : Ball Bearing

Lead Wire : UL1007, AWG26, +Red, -Black

Specifications

MODEL	Product No.	Rated Voltage	Operating Voltage	Current	Input Power	Speed	Max. Air Flow		Max. Static Pressure		Noise	Mass
		(V)	(V)	(A) ^{*1}	(W) ^{*1}	(min ⁻¹) ^{*1}	CFM ^{*1}	(m ³ /min) ^{*1}	in H ₂ O	(Pa) ^{*1}	(dB) ^{*1}	(g)
** 2415KL-04W-B40-	E00	12	8.0 ~ 13.8	0.44	5.28	7000	39.5	1.12	0.59	148.0	47.0	115
** 2415KL-04W-B60-	E00	12	10.8 ~ 13.8	0.83	10.0	9000	49.4	1.40	0.98	245.0	53.0	115
** 2415KL-04W-B80-	E00	12	7.0 ~ 12.6	1.30	15.6	11000	64.9	1.84	1.52	379.0	57.5	115

Rotation: Clockwise

Airflow Outlet: Air Out Over Struts

*1: Average Values in Free Air

** Contact NMB for availability



General Specifications

Motor Protection:

Auto Restart/Polarity Protection

Insulation Resistance:

10M Ω or over with a DC500V Megger

Dielectric Withstand Voltage: AC 700V 1s

Allowable Ambient Temperature Range:

-10°C ~ +70°C (Operating)

-40°C ~ +70°C (Storage)

(non-condensing environment)

Expected Life

Failure Rate: 10%

25°C 70,000 Hours (P00)

Outline

Units: $\frac{\text{inch}}{\text{mm}}$

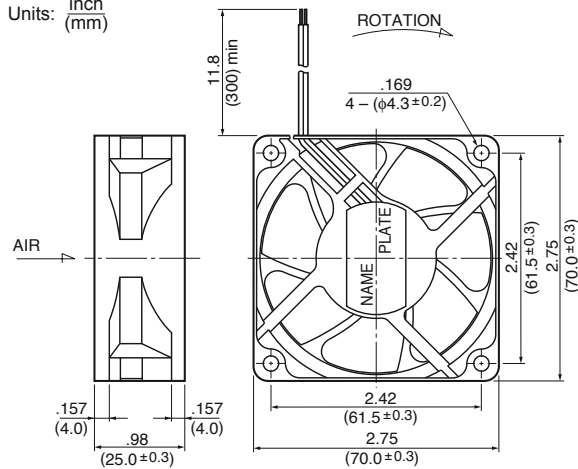

Characteristic Curves

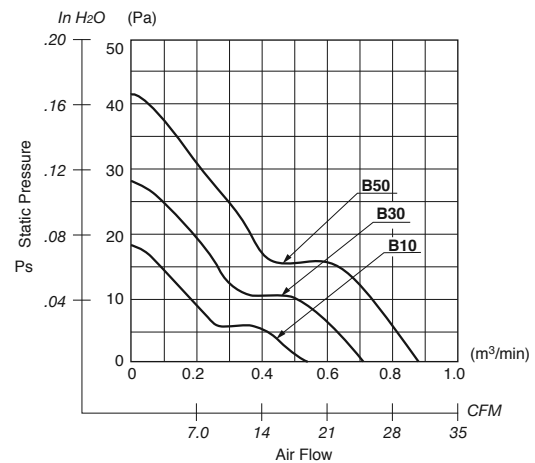

Panel Cut-outs

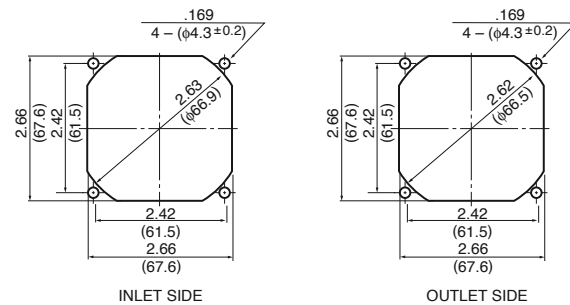

Material

Casing : Plastic (Black) 94V-0

Impeller : Plastic (Black) 94V-0

Bearing : Ball Bearing

Lead Wire: UL1007, AWG24, +Red, -Black

Specifications

MODEL	Product No.	Rated Voltage	Operating Voltage	Current	Input Power	Speed	Max. Air Flow		Max. Static Pressure		Noise	Mass
		(V)	(V)	(A) ^{*1}	(W) ^{*1}	(min ⁻¹) ^{*1}	CFM ^{*1}	(m ³ /min) ^{*1}	in H ₂ O	(Pa) ^{*1}	(dB) ^{*1}	(g)
2810KL-04W-B10-	X00	12	6.0 ~ 13.8	0.09	1.08	2400	19.0	0.54	.07	18.0	21.5	72
2810KL-04W-B30-	X00	12	6.0 ~ 13.8	0.15	1.80	3150	25.0	0.71	.11	28.4	28.0	72
2810KL-04W-B50-	X00	12	6.0 ~ 13.8	0.18	2.16	3800	31.0	0.88	.16	41.1	33.5	72
** 2810KL-04W-B70-	X00	12	6.0 ~ 13.0	0.35	4.20	5000	40.6	1.15	.28	71.7	43.0	72

Rotation: Clockwise

Airflow Outlet: Air Out Over Struts

*1: Average Values in Free Air

** Contact NMB for availability



General Specifications

Motor Protection:

Auto Restart/Polarity Protection

Insulation Resistance:

10M Ω or over with a DC500V Megger

Dielectric Withstand Voltage: AC 700V 1s

Allowable Ambient Temperature Range:

B50 Class: -10°C ~ +50°C (Operating)

B30, B40 Class: -10°C ~ +60°C (Operating)

All Class: -40°C ~ +60°C (Storage)

(non-condensing environment)

Expected Life

Failure Rate: 10%

25°C 70,000 Hours (B00)

Outline

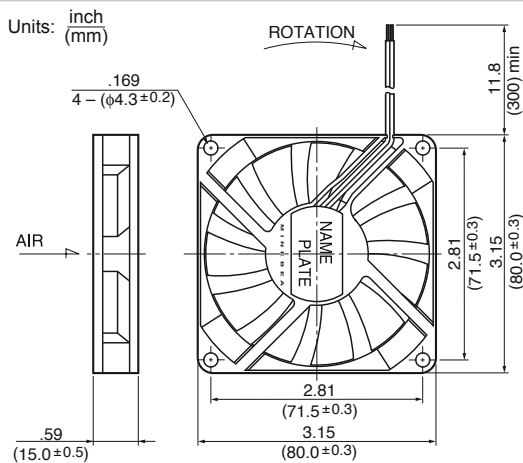

Characteristic Curves

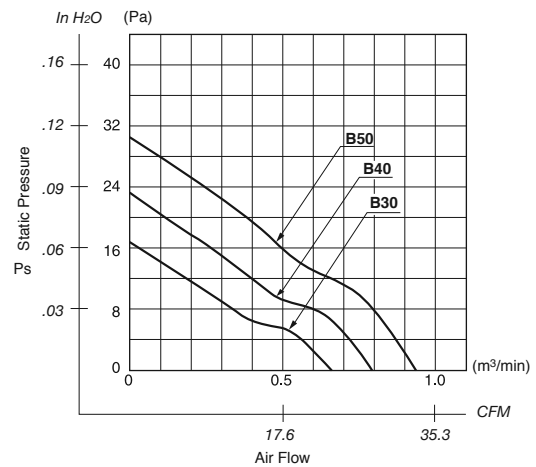

Panel Cut-outs

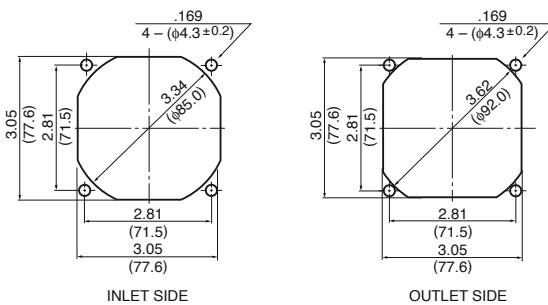

Material

Casing : Plastic (Black) 94V-0

Impeller : Plastic (Black) 94V-0

Bearing : Ball Bearing

Lead Wire: UL1007, AWG26, +Red, -Black

Specifications

MODEL	Product No.	Rated Voltage	Operating Voltage	Current	Input Power	Speed	Max. Air Flow		Max. Static Pressure		Noise	Mass
		(V)	(V)	(A) ^{*1}	(W) ^{*1}	(min ⁻¹) ^{*1}	CFM ^{*1}	(m ³ /min) ^{*1}	in H ₂ O	(Pa) ^{*1}	(dB) ^{*1}	(g)
3106KL-04W-B30-	X00	12	6.0 ~ 13.8	0.11	1.32	2200	23.3	0.66	0.06	16.0	26.0	50
** 3106KL-04W-B40-	X00	12	6.0 ~ 13.8	0.17	2.04	2600	28.2	0.80	0.09	22.5	30.0	50
3106KL-04W-B50-	X00	12	6.0 ~ 13.0	0.23	2.76	3000	32.8	0.93	0.12	30.0	34.0	50

Rotation: Clockwise

Airflow Outlet: Air Out Over Struts

*1: Average Values in Free Air

** Contact NMB for availability



General Specifications

Motor Protection:

Auto Restart/Polarity Protection

Insulation Resistance:

10M Ω or over with a DC500V Megger

Dielectric Withstand Voltage: AC 700V 1s

Allowable Ambient Temperature Range:

-10°C ~ +70°C (Operating)

-40°C ~ +70°C (Storage)

(non-condensing environment)

Expected Life

Failure Rate: 10%

25°C 60,000 Hours (L00, P00)

Characteristic Curves

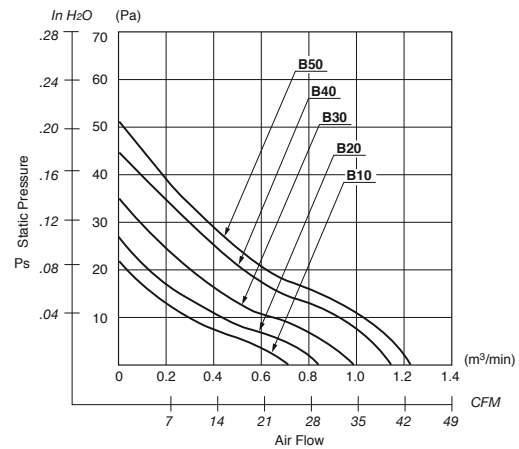

Outline

Units: inch (mm)

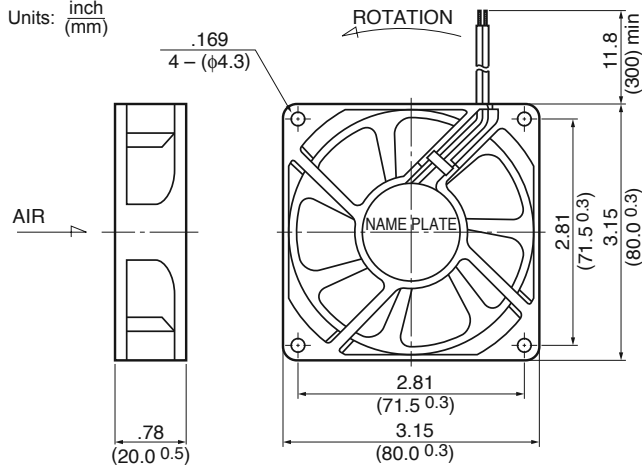

Panel Cut-outs

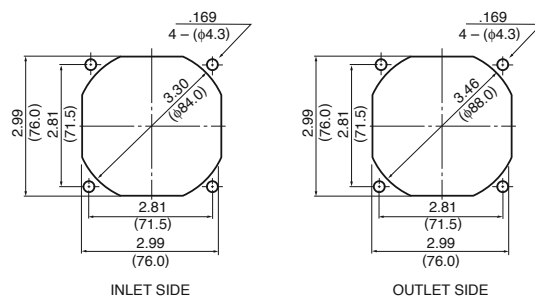

Material

Casing : Plastic (Black) 94V-0

Impeller : Plastic (Black) 94V-0

Bearing : Ball Bearing

Lead Wire: UL1007, AWG24, +Red, -Black

Specifications

MODEL	Product No.	Rated Voltage	Operating Voltage	Current	Input Power	Speed	Max. Air Flow		Max. Static Pressure		Noise	Mass
		(V)	(V)	(A) ^{*1}	(W) ^{*1}	(min ⁻¹) ^{*1}	CFM ^{*1}	(m ³ /min) ^{*1}	in H ₂ O	(Pa) ^{*1}	(dB) ^{*1}	(g)
3108NL-04W-B10-	X00	12	6.0 ~ 13.8	0.09	1.08	2350	26.5	0.75	.08	21.0	26.0	85
3108NL-04W-B20-	X00	12	6.0 ~ 13.8	0.11	1.32	2600	29.6	0.84	.10	26.0	29.0	85
3108NL-04W-B30-	X00	12	6.0 ~ 13.8	0.14	1.68	2950	34.6	0.98	.13	33.5	32.5	85
3108NL-04W-B40-	X00	12	6.0 ~ 13.8	0.20	2.40	3350	40.6	1.15	.17	43.7	38.5	85
3108NL-04W-B50-	X00	12	6.0 ~ 13.8	0.28	3.36	3750	44.0	1.25	.20	50.1	42.0	85
3108NL-05W-B10-	X00	24	15.0 ~ 27.6	0.05	1.30	2350	26.5	0.75	.08	21.0	26.0	85
3108NL-05W-B20-	X00	24	15.0 ~ 27.6	0.06	1.44	2600	29.6	0.84	.10	26.0	29.0	85
3108NL-05W-B30-	X00	24	15.0 ~ 27.6	0.07	1.68	2950	34.6	0.98	.13	33.5	32.5	85
3108NL-05W-B40-	X00	24	15.0 ~ 27.6	0.11	2.64	3350	40.6	1.15	.17	43.7	38.5	85
3108NL-05W-B50-	X00	24	15.0 ~ 27.6	0.15	3.60	3750	44.0	1.25	.20	50.1	42.0	85

Rotation: Clockwise

Airflow Outlet: Air Out Over Struts

*1: Average Values in Free Air



General Specifications

Motor Protection:

Auto Restart/Polarity Protection

Insulation Resistance:

10M Ω or over with a DC500V Megger

Dielectric Withstand Voltage: AC 700V 1s

Allowable Ambient Temperature Range:

B70: -10°C ~ +60°C (Operating)

B10 ~ B60 Class: -10°C ~ +70°C (Operating)

All Class: -40°C ~ +70°C (Storage)
(non-condensing environment)

Expected Life

Failure Rate: 10%

25°C 100,000 Hours (E00)

25°C 70,000 Hours (G00, D00)

Characteristic Curves

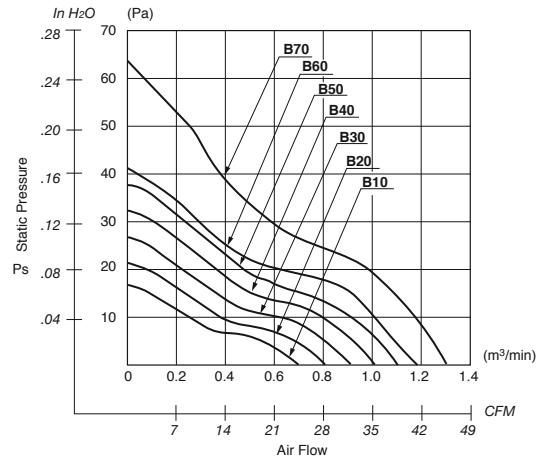

Outline

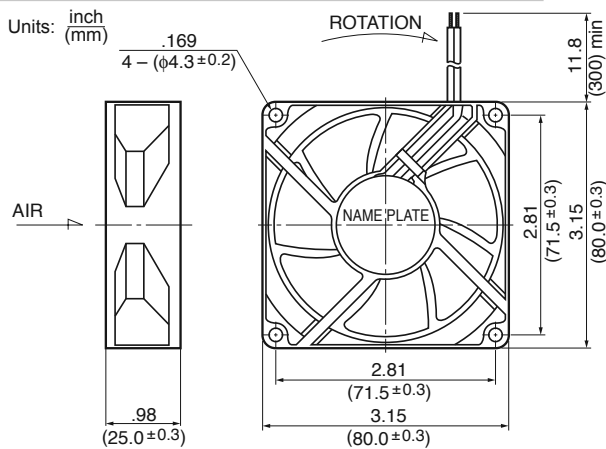

Panel Cut-outs

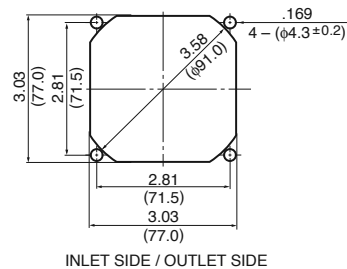

Material

Casing : Plastic (Black) 94V-0

Impeller : Plastic (Black) 94V-0

Bearing : Ball Bearing

Lead Wire: UL1007, AWG24, +Red, -Black

Specifications

MODEL	Product No.	Rated Voltage	Operating Voltage	Current	Input Power	Speed	Max. Air Flow		Max. Static Pressure		Noise	Mass
		(V)	(V)	(A) ^{*1}	(W) ^{*1}	(min ⁻¹) ^{*1}	CFM ^{*1}	(m ³ /min) ^{*1}	in H ₂ O	(Pa) ^{*1}	(dB) ^{*1}	(g)
** 3110KL-04W-B10-	X00	12	6.0 ~ 13.8	0.10	1.20	2150	24.7	0.7	0.07	16.7	22.0	95
** 3110KL-04W-B20-	X00	12	6.0 ~ 13.8	0.11	1.32	2400	28.2	0.80	.08	21.6	25.0	95
** 3110KL-04W-B30-	X00	12	6.0 ~ 13.8	0.17	2.04	2700	31.8	0.90	.10	26.5	28.0	95
** 3110KL-04W-B40-	X00	12	6.0 ~ 13.8	0.20	2.40	3000	35.3	1.00	.13	32.3	31.0	95
** 3110KL-04W-B50-	X00	12	6.0 ~ 13.8	0.23	2.76	3250	38.8	1.10	.15	37.2	34.0	95
** 3110KL-04W-B60-	X00	12	6.0 ~ 13.0	0.26	3.12	3400	40.2	1.14	.16	40.2	35.0	95
** 3110KL-04W-B70-	X00	12	6.0 ~ 13.8	0.29	3.86	4000	45.9	1.30	.26	64.4	40.0	95
** 3110KL-05W-B10-	X00	24	10.0 ~ 27.6	0.06	1.44	2150	24.7	0.70	.07	16.7	22.0	95
** 3110KL-05W-B20-	X00	24	10.0 ~ 27.6	0.07	1.68	2400	28.2	0.80	.08	21.6	25.0	95
** 3110KL-05W-B30-	X00	24	10.0 ~ 27.6	0.08	1.92	2700	31.8	0.90	.10	26.5	28.0	95
** 3110KL-05W-B40-	X00	24	10.0 ~ 27.6	0.10	2.40	3000	35.3	1.00	.13	32.3	31.0	95
** 3110KL-05W-B50-	X00	24	10.0 ~ 27.6	0.12	2.88	3250	38.8	1.10	.15	37.2	34.0	95
** 3110KL-05W-B60-	X00	24	10.0 ~ 26.4	0.14	3.36	3400	40.2	1.14	.16	40.2	35.0	95
** 3110KL-05W-B70-	X00	24	10.0 ~ 26.4	0.16	3.84	4000	45.8	1.30	.25	64.4	40.0	95

Rotation: Clockwise

Airflow Outlet: Air Out Over Struts

*1: Average Values in Free Air

** Contact NMB for availability



General Specifications

Motor Protection:

Auto Restart/Polarity Protection

Insulation Resistance:

10M Ω or over with a DC500V Megger

Dielectric Withstand Voltage: AC 700V 1s

Allowable Ambient Temperature Range:

B60 Class: -10°C ~ +60°C (Operating)

B30 ~ B50 Class: -10°C ~ +70°C (Operating)

All Class: -40°C ~ +70°C (Storage)

(non-condensing environment)

Expected Life

Failure Rate: 10%

25°C 100,000 Hours (E00)

Outline

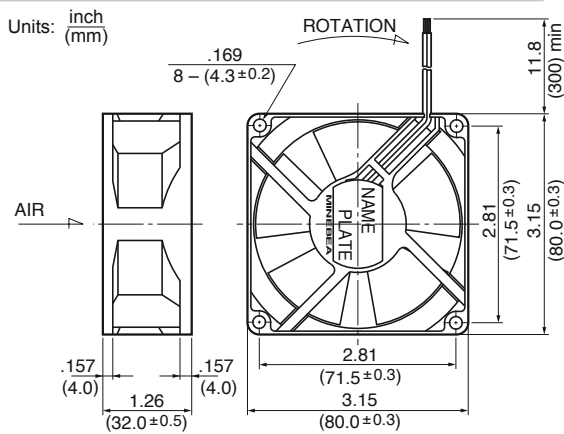

Characteristic Curves

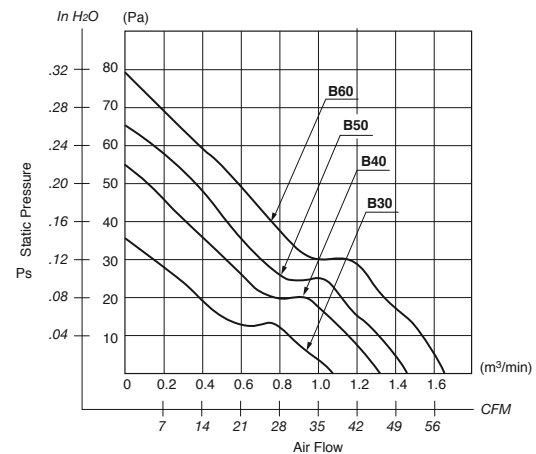

Panel Cut-outs

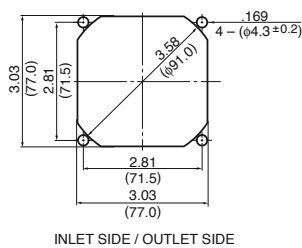

Material

Casing : Plastic (Black) 94V-0

Impeller : Plastic (Black) 94V-0

Bearing : Ball Bearing

Lead Wire : UL1007, AWG24, +Red, -Black

Specifications

MODEL	Product No.	Rated Voltage	Operating Voltage	Current	Input Power	Speed	Max. Air Flow		Max. Static Pressure		Noise	Mass
		(V)	(V)	(A) ^{*1}	(W) ^{*1}	(min ⁻¹) ^{*1}	CFM ^{*1}	(m ³ /min) ^{*1}	in H ₂ O	(Pa) ^{*1}	(dB) ^{*1}	(g)
3112KL-04W-B30-	X00	12	6.0 ~ 13.8	0.17	2.04	2850	38.1	1.08	.14	35.2	32.0	95
** 3112KL-04W-B40-	X00	12	6.0 ~ 13.8	0.25	3.00	3350	46.9	1.33	.22	54.5	37.0	95
3112KL-04W-B50-	X00	12	6.0 ~ 12.6	0.35	4.20	3850	51.5	1.46	.26	65.1	41.0	95
** 3112KL-04W-B60-	X00	12	6.0 ~ 12.6	0.45	5.40	4350	58.6	1.66	.32	78.9	44.0	95
3112KL-05W-B30-	X00	24	10.0 ~ 27.6	0.10	2.40	2850	38.1	1.08	.14	35.2	32.0	95
3112KL-05W-B40-	X00	24	10.0 ~ 27.6	0.14	3.36	3350	46.9	1.33	.22	54.5	37.0	95
3112KL-05W-B50-	X00	24	10.0 ~ 25.2	0.19	4.56	3850	51.5	1.46	.26	65.1	41.0	95
3112KL-05W-B60-	X00	24	10.0 ~ 25.2	0.21	5.04	4350	58.6	1.66	.32	78.9	44.0	95

Rotation: Clockwise

Airflow Outlet: Air Out Over Struts

*1: Average Values in Free Air

** Contact NMB for availability



General Specifications

Motor Protection:

Auto Restart/Polarity Protection

Insulation Resistance:

10M Ω or over with a DC500V Megger

Dielectric Withstand Voltage: AC 700V 1s

Allowable Ambient Temperature Range:

B60 Class: -10°C ~ +50°C (Operating)

B10 ~ B50 Class: -10°C ~ +70°C (Operating)

All Class: -40°C ~ +70°C (Storage)
(non-condensing environment)

Expected Life

Failure Rate: 10%

** 25°C 100,000 Hours (B00, E00)

25°C 70,000 Hours (G00, D00)

Characteristic Curves

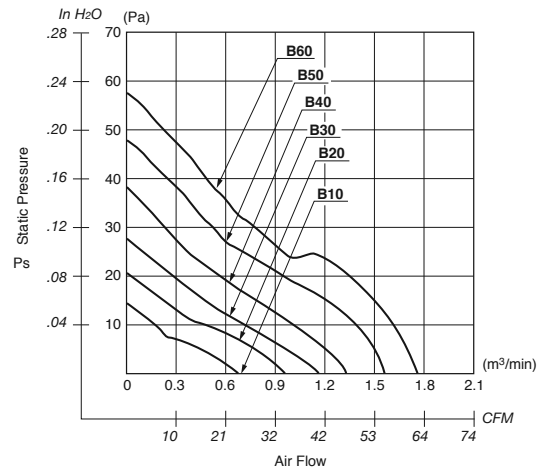

Outline

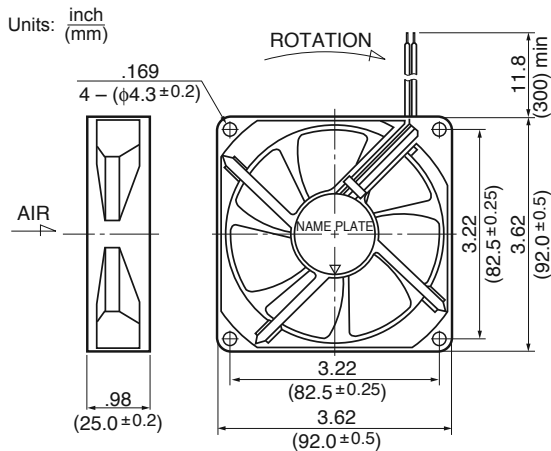

Panel Cut-outs

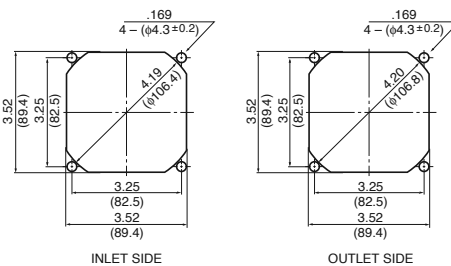

Material

Casing : Plastic (Black) 94V-0

Impeller : Plastic (Black) 94V-0

Bearing : Ball Bearing

Lead Wire : UL1007, AWG24, +Red, -Black

Specifications

MODEL	Product No.	Rated Voltage	Operating Voltage	Current (A) ^{*1}	Input Power (W) ^{*1}	Speed (min ⁻¹) ^{*1}	Max. Air Flow		Max. Static Pressure		Noise (dB) ^{*1}	Mass (g)
		(V)	(V)				CFM ^{*1}	(m ³ /min) ^{*1}	in H ₂ O	(Pa) ^{*1}		
** 3610KL-04W-B10-	X00	12	6.0 ~ 13.8	0.073	0.876	1750	26.5	0.75	.06	14.2	25.0	95
3610KL-04W-B20-	X00	12	6.0 ~ 13.8	0.11	1.320	2100	33.5	0.95	.08	20.1	29.5	95
3610KL-04W-B30-	X00	12	6.0 ~ 13.8	0.16	1.920	2450	40.6	1.15	.11	27.0	34.0	95
3610KL-04W-B40-	X00	12	6.0 ~ 13.8	0.22	2.640	2850	47.6	1.35	.15	37.2	37.5	95
3610KL-04W-B50-	X00	12	6.0 ~ 13.0	0.315	3.760	3200	54.7	1.55	.19	48.0	41.0	85
** 3610KL-04W-B60-	X00	12	6.0 ~ 12.6	0.43	5.160	3600	61.8	1.75	.23	57.2	44.5	95
** 3610KL-05W-B10-	X00	24	10.0 ~ 27.6	0.05	1.20	1750	26.5	0.75	.06	14.2	25.0	95
3610KL-05W-B20-	X00	24	10.0 ~ 27.6	0.06	1.44	2100	33.5	0.95	.08	20.1	29.5	95
3610KL-05W-B30-	X00	24	10.0 ~ 27.6	0.09	2.16	2450	40.6	1.15	.11	27.0	34.0	95
3610KL-05W-B40-	X00	24	10.0 ~ 27.6	0.12	2.88	2850	47.6	1.35	.15	37.2	37.5	95
3610KL-05W-B50-	X00	24	10.0 ~ 25.0	0.16	3.84	3200	54.7	1.55	.19	48.0	41.0	95
3610KL-05W-B60-	X00	24	10.0 ~ 25.0	0.20	4.80	3600	61.8	1.75	.23	57.2	44.5	95

Rotation: Clockwise

Airflow Outlet: Air Out Over Struts

*1: Average Values in Free Air

** Contact NMB for availability



General Specifications

Motor Protection:

Auto Restart/Polarity Protection

Insulation Resistance:

10M Ω or over with a DC500V Megger

Dielectric Withstand Voltage: AC 700V 1s

Allowable Ambient Temperature Range:

B60 Class: -10°C ~ +50°C (Operating)

B10 ~ B50 Class: -10°C ~ +70°C (Operating)

All Class: -40°C ~ +70°C (Storage)
(non-condensing environment)

Expected Life

Failure Rate: 10%

25°C 60,000 Hours (X00)

Characteristic Curves

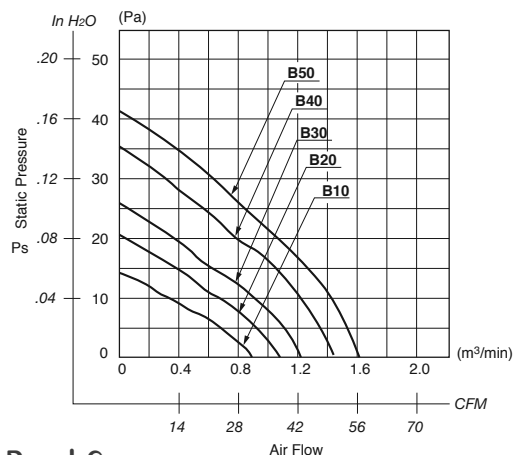

Panel Cut-outs

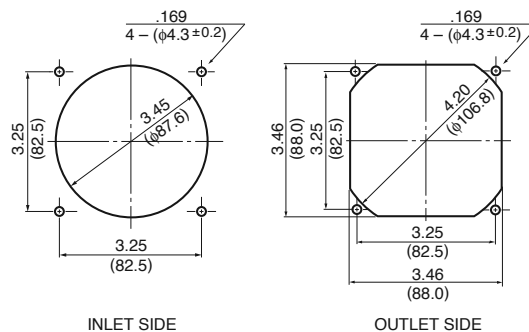

Outline

Units: inch (mm)

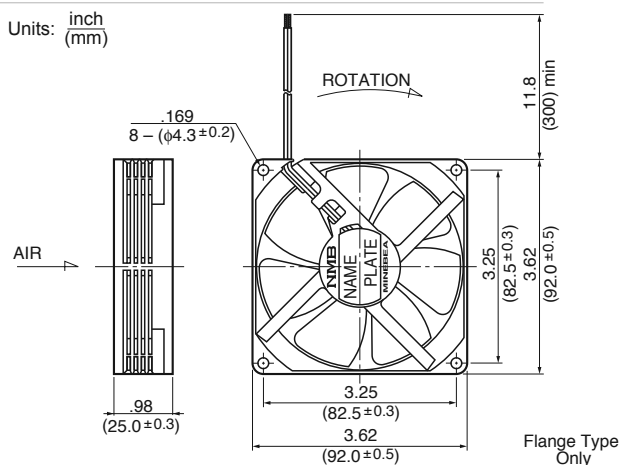

Material

Casing : Plastic (Black) 94V-0
 Impeller : Plastic (Black) 94V-0
 Bearing : Ball Bearing
 Lead Wire : UL1007, AWG26, +Red, -Black

Specifications

MODEL	Product No.	Rated Voltage	Operating Voltage	Current	Input Power	Speed	Max. Air Flow		Max. Static Pressure		Noise	Mass
		(V)	(V)	(A) ^{*1}	(W) ^{*1}	(min ⁻¹) ^{*1}	CFM ^{*1}	(m ³ /min) ^{*1}	in H ₂ O	(Pa) ^{*1}	(dB) ^{*1}	(g)
3610KL-04W-B10-	X00	12	6.0 ~ 13.8	0.07	0.84	1750	31.4	0.89	.05	14.1	25.0	95
3610KL-04W-B20-	X00	12	6.0 ~ 13.8	0.11	1.32	2100	38.1	1.08	.08	20.5	27.0	95
3610KL-04W-B30-	X00	12	6.0 ~ 13.8	0.16	1.92	2450	43.0	1.22	.10	28.0	30.5	95
3610KL-04W-B40-	X00	12	6.0 ~ 13.8	0.22	2.64	2850	50.8	1.44	.14	35.4	34.0	95
3610KL-04W-B50-	X00	12	6.0 ~ 13.0	0.32	3.84	3200	56.8	1.61	.17	42.0	37.0	85
3610KL-04W-B60-	X00	12	6.0 ~ 12.6	0.43	5.16	3600	62.8	1.78	.20	50.0	39.5	95
3610KL-05W-B10-	X00	24	10.0 ~ 27.6	0.05	1.20	1750	31.4	0.89	.05	14.1	25.0	95
3610KL-05W-B20-	X00	24	10.0 ~ 27.6	0.06	1.44	2100	38.1	1.08	.08	20.5	27.0	95
3610KL-05W-B30-	X00	24	10.0 ~ 27.6	0.09	2.16	2450	43.0	1.22	.10	26.0	30.5	95
3610KL-05W-B40-	X00	24	10.0 ~ 27.6	0.12	2.88	2850	50.8	1.44	.14	35.4	34.0	95
3610KL-05W-B50-	X00	24	10.0 ~ 25.0	0.16	3.84	3200	56.8	1.61	.17	42.0	37.0	95

Rotation: Clockwise

Airflow Outlet: Air Out Over Struts

*1: Average Values in Free Air



General Specifications

Motor Protection:

Auto Restart/Polarity Protection

Insulation Resistance:

10M Ω or over with a DC500V Megger

Dielectric Withstand Voltage: AC 700V 1s

Allowable Ambient Temperature Range:

-10°C ~ +60°C (Operating)

-40°C ~ +70°C (Storage)

(non-condensing environment)

Expected Life

Failure Rate: 10%

25°C 100,000 Hours (B00, E00)

Outline

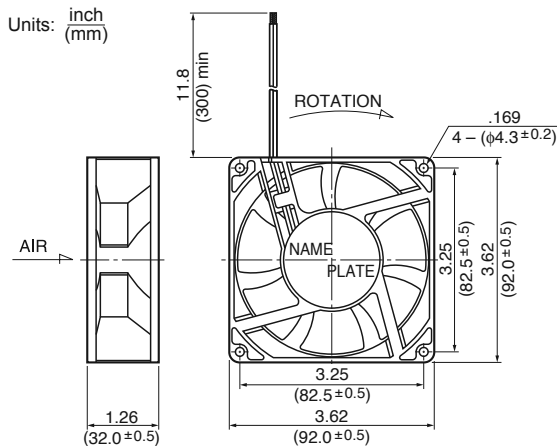

Panel Cut-outs

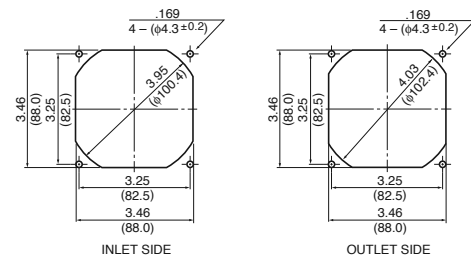

Characteristic Curves

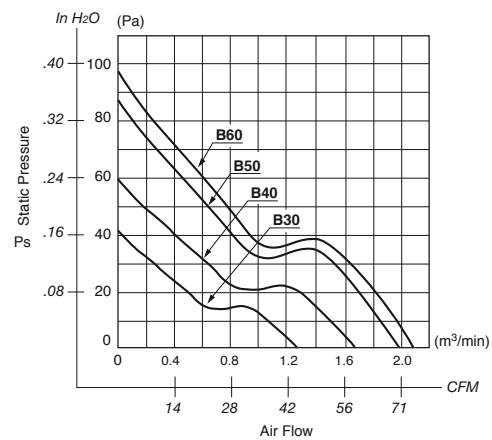

Material

Casing : Plastic (Black) 94V-0

Impeller : Plastic (Black) 94V-0

Bearing : Ball Bearing

Lead Wire : UL1007, AWG24, +Red, -Black

Specifications

MODEL	Product No.	Rated Voltage	Operating Voltage	Current	Input Power	Speed	Max. Air Flow		Max. Static Pressure		Noise	Mass
		(V)	(V)	(A) ^{*1}	(W) ^{*1}	(min ⁻¹) ^{*1}	CFM ^{*1}	(m ³ /min) ^{*1}	in H ₂ O	(Pa) ^{*1}	(dB) ^{*1}	(g)
** 3612KL-04W-B30-	X00	12	6.0 ~ 13.8	0.21	2.52	2600	47.3	1.34	.16	41.0	34.0	230
** 3612KL-04W-B40-	X00	12	6.0 ~ 13.8	0.31	3.72	3200	58.6	1.66	.24	61.1	38.0	230
** 3612KL-04W-B50-	X00	12	6.0 ~ 13.8	0.47	5.64	3800	69.9	1.98	.33	83.0	43.5	230
** 3612KL-04W-B60-	X00	12	10.5 ~ 13.2	0.48	5.76	4000	70.5	2.00	.38	96.0	44.0	230
** 3612KL-05W-B30-	X00	24	15.0 ~ 27.6	0.10	2.40	2600	47.3	1.34	.16	41.0	34.0	230
** 3612KL-05W-B40-	X00	24	15.0 ~ 27.6	0.16	3.84	3200	58.6	1.66	.24	61.0	38.0	230
** 3612KL-05W-B50-	X00	24	15.0 ~ 27.6	0.25	6.00	3800	69.9	1.98	.33	83.0	43.5	230
** 3612KL-05W-B60-	X00	24	10.0 ~ 27.6	0.23	5.52	4000	70.5	1.98	.33	83.0	43.5	230

Rotation: Clockwise

Airflow Outlet: Air Out Over Struts

*1: Average Values in Free Air

** Contact NMB for availability



General Specifications

Motor Protection:

Auto Restart/Polarity Protection

Insulation Resistance:

10M Ω or over with a DC500V Megger

Dielectric Withstand Voltage: AC 700V 1s

Allowable Ambient Temperature Range:

B50 Class: -10°C ~ +60°C (Operating)

B30 ~ B40 Class: -10°C ~ +70°C (Operating)

All Class: -40°C ~ +70°C (Storage)
(non-condensing environment)

Expected Life

Failure Rate: 10%

25°C 100,000 Hours (P00)

Characteristic Curves

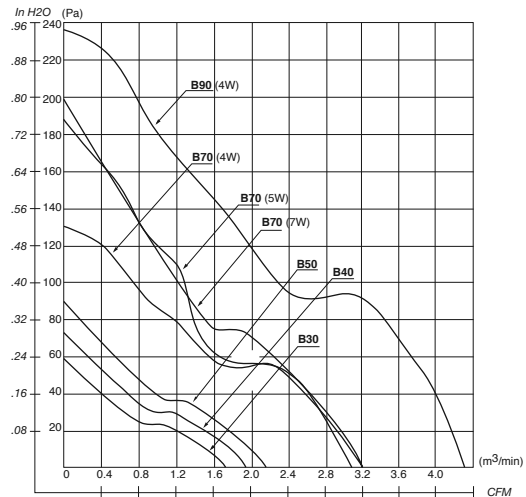

Outline

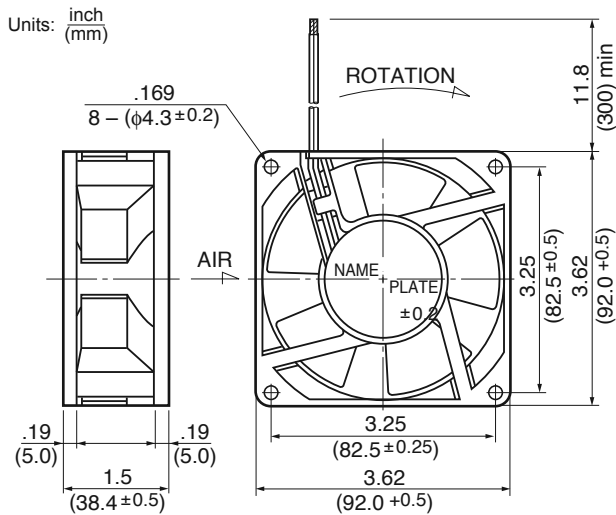

Panel Cut-outs

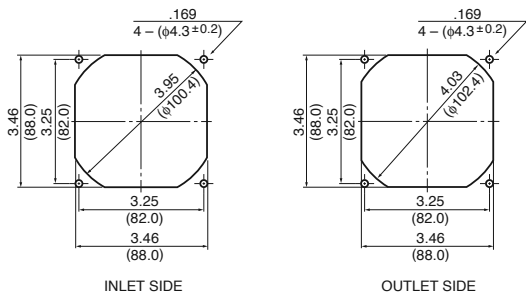

Material

- Casing : Plastic (Black) 94V-0
- Impeller : Plastic (Black) 94V-0
- Bearing : Ball Bearing
- Lead Wire: UL1061, AWG26, +Red, -Black

Specifications

MODEL	Product No.	Rated Voltage	Operating Voltage	Current	Input Power	Speed	Max. Air Flow		Max. Static Pressure		Noise	Mass
		(V)	(V)	(A) ^{*1}	(W) ^{*1}	(min ⁻¹) ^{*1}	CFM ^{*1}	(m ³ /min) ^{*1}	in H ₂ O	(Pa) ^{*1}	(dB) ^{*1}	(g)
3615KL-04W-B30-	P00	12	7.0 ~ 13.2	0.25	3.00	3200	60.3	1.71	.23	57.9	40.5	210
3615KL-04W-B40-	P00	12	7.0 ~ 13.2	0.34	4.08	3600	68.5	1.94	.29	72.0	44.0	210
3615KL-04W-B50-	P00	12	7.0 ~ 12.6	0.46	5.52	4000	76.2	2.16	.36	89.2	46.5	210
** 3615KL-04W-B70-	P00	12	10.8 ~ 12.6	1.30	15.60	4650	111.9	3.17	.53	133.0	50.0	210
** 3615KL-04W-B90-	P00	12	6.0 ~ 12.6	2.10	25.20	6000	151.7	4.30	.96	240.0	57.5	210
3615KL-05W-B30-	P00	24	12.0 ~ 26.4	0.15	3.60	3200	60.3	1.71	.23	57.9	40.5	210
** 3615KL-05W-B40-	P00	24	12.0 ~ 26.4	0.20	4.80	3600	68.5	1.94	.29	72.0	44.0	210
3615KL-05W-B50-	P00	24	12.0 ~ 25.2	0.24	5.76	4000	76.2	2.16	.36	89.2	46.5	210
** 3615KL-05W-B70-	P00	24	15.0 ~ 26.4	0.70	16.8	5900	105.9	3.00	.75	189.0	53.0	210
** 3615KL-07W-B70-	P00	48	30.0 ~ 50.2	0.36	17.3	5800	110.0	3.10	.71	178.0	55.0	210

Rotation: Clockwise

Airflow Outlet: Air Out Over Struts

*1: Average Values in Free Air

** Contact NMB for availability



General Specifications

Motor Protection:

Auto Restart/Polarity Protection

Insulation Resistance:

10M Ω or over with a DC500V Megger

Dielectric Withstand Voltage: AC 700V 1s

Allowable Ambient Temperature Range:

-10°C ~ +70°C (Operating)

-40°C ~ +70°C (Storage)

(non-condensing environment)

Expected Life

Failure Rate: 10%

40°C 50,000 Hours

Outline

Units: $\frac{\text{inch}}{\text{mm}}$

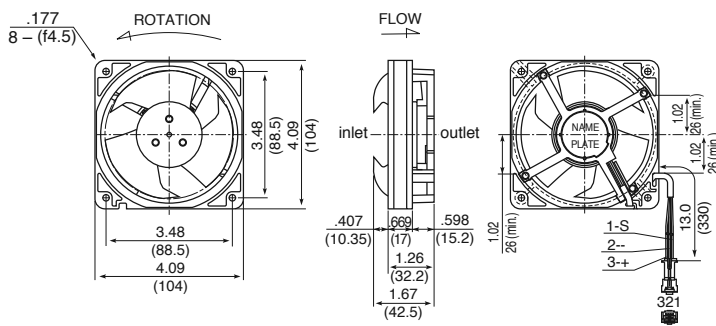

Housing with solid corner type are available.

Characteristic Curves

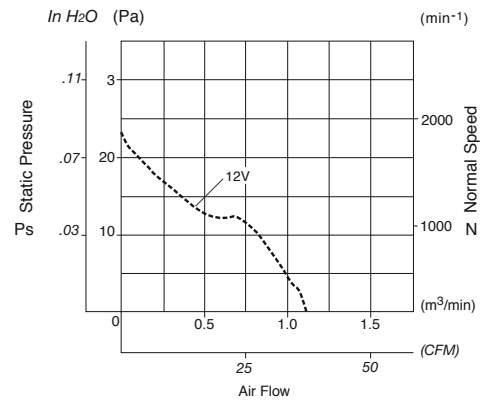

Panel Cut-outs

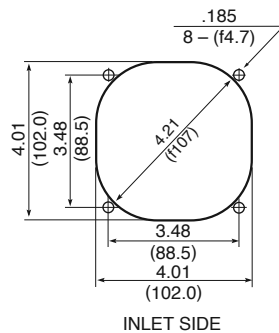

Material

Bearing : Hydro Wave Bearing

Specifications

MODEL	Rated Voltage	Operating Voltage	Current	Input Power	Rated Speed	Max. Air Flow		Max. Static Pressure		Noise	Mass
	(V)	(V)	(A) ^{*1}	(W) ^{*1}	(min ⁻¹) ^{*1}	CFM ^{*1}	(m ³ /min) ^{*1}	in H ₂ O	(Pa) ^{*1}	(dB) ^{*1}	(g)
FBA10J12L	12	7.0 ~ 14.0	121	1.45	2200	38.8	1.1	.08	22.0	30.0	170

Rotation: Clockwise

Airflow Outlet: Air Out Over Struts

*1: Average Values in Free Air



General Specifications

Motor Protection:

Auto Restart/Polarity Protection

Insulation Resistance:

10M Ω or over with a DC500V Megger

Dielectric Withstand Voltage: AC 700V 1s

Allowable Ambient Temperature Range:

B50 Class: -10°C ~ +60°C (Operating)

B10 ~ B40 Class: -10°C ~ +70°C (Operating)

All Class: -40°C ~ +70°C (Storage)
(non-condensing environment)

Expected Life

Failure Rate: 10%

25°C 100,000 Hours (B00, E00)

Characteristic Curves

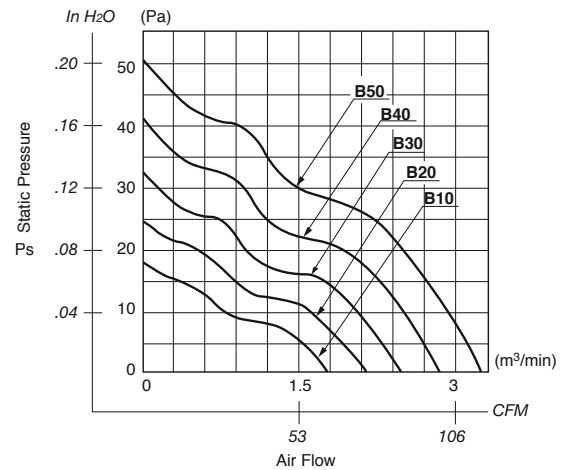

Outline

Units: inch (mm)

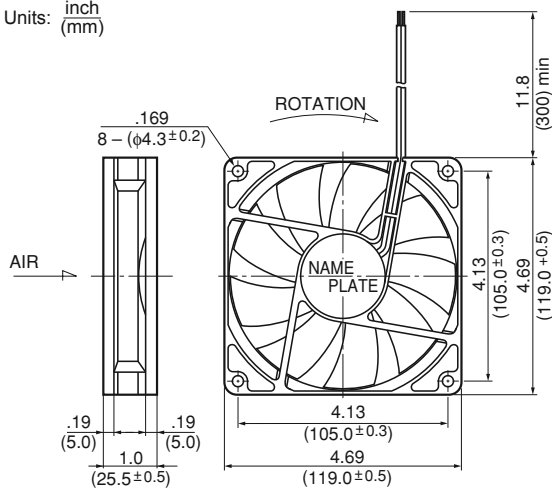

Panel Cut-outs

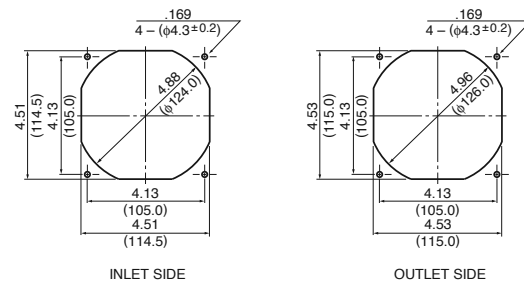

Material

Casing : Plastic (Black) 94V-0

Impeller : Plastic (Black) 94V-0

Bearing : Ball Bearing

Lead Wire : UL1007, AWG24, +Red, -Black

Specifications

MODEL	Product No.	Rated Voltage	Operating Voltage	Current	Input Power	Speed	Max. Air Flow		Max. Static Pressure		Noise	Mass
		(V)	(V)	(A) ^{*1}	(W) ^{*1}	(min ⁻¹) ^{*1}	CFM ^{*1}	(m ³ /min) ^{*1}	in H ₂ O	(Pa) ^{*1}	(dB) ^{*1}	(g)
4710KL-04W-B10-	X00	12	6.0 ~ 13.8	0.12	1.44	1600	63.5	1.80	.07	17.9	27.0	180
4710KL-04W-B20-	X00	12	6.0 ~ 13.8	0.19	2.28	1900	75.9	2.15	.10	24.8	31.0	180
4710KL-04W-B30-	X00	12	6.0 ~ 13.8	0.28	3.36	2200	88.2	2.50	.13	32.3	35.0	180
4710KL-04W-B40-	X00	12	6.0 ~ 13.8	0.40	4.80	2500	100.6	2.85	.16	40.9	38.5	180
4710KL-04W-B50-	X00	12	6.0 ~ 13.0	0.55	6.60	2800	114.7	3.25	.20	50.5	41.5	180
4710KL-05W-B10-	X00	24	10.0 ~ 27.6	0.08	1.92	1600	63.5	1.80	.07	17.9	27.0	180
4710KL-05W-B20-	X00	24	10.0 ~ 27.6	0.10	2.40	1900	75.9	2.15	.10	24.8	31.0	180
4710KL-05W-B30-	X00	24	10.0 ~ 27.6	0.15	3.60	2200	88.2	2.50	.13	32.3	35.0	180
4710KL-05W-B40-	X00	24	10.0 ~ 27.6	0.22	5.28	2500	100.6	2.85	.16	40.9	38.5	180
4710KL-05W-B50-	X00	24	10.0 ~ 26.0	0.29	6.96	2800	114.7	3.25	.20	50.5	41.5	180

Rotation: Clockwise

Airflow Outlet: Air Out Over Struts

*1: Average Values in Free Air

** Contact NMB for availability



General Specifications

Motor Protection:

Auto Restart/Polarity Protection

Insulation Resistance:

10M Ω or over with a DC500V Megger

Dielectric Withstand Voltage: AC 700V 1s

Allowable Ambient Temperature Range:

-10°C ~ +70°C (Operating)

-40°C ~ +70°C (Storage)

(non-condensing environment)

Expected Life

Failure Rate: 10%

25°C 100,000 Hours (P00)

Outline

Units: inch
(mm)

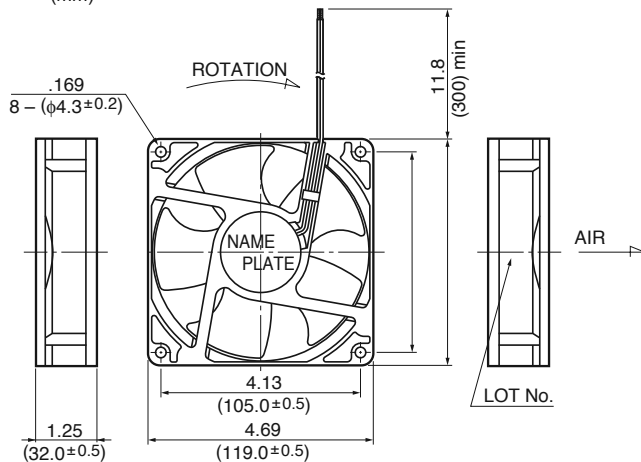

Characteristic Curves

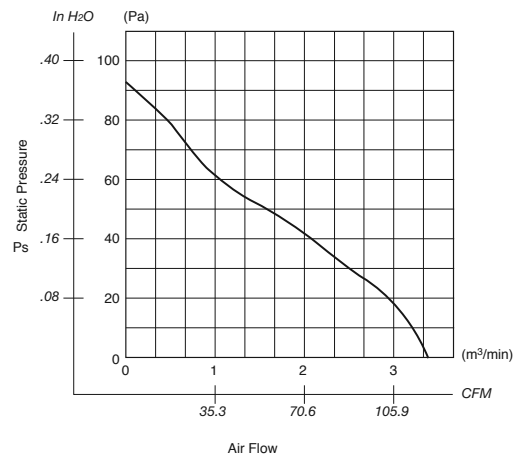

Panel Cut-outs

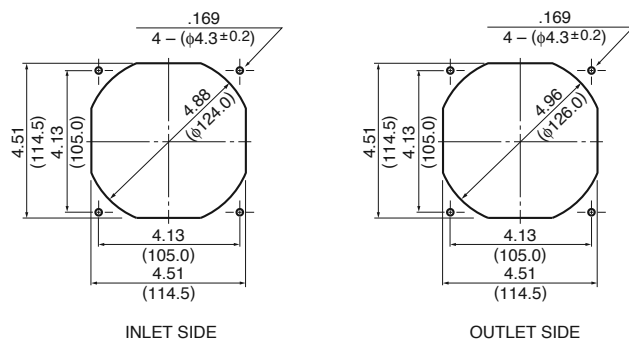

Material

- Casing : Plastic (Black) 94V-0
- Impeller : Plastic (Black) 94V-0
- Bearing : Ball Bearing
- Lead Wire: UL1061, AWG22, +Red, -Black

Specifications

MODEL	Product No.	Rated Voltage	Operating Voltage	Current	Input Power	Speed	Max. Air Flow		Max. Static Pressure		Noise	Mass
		(V)	(V)	(A) ^{*1}	(W) ^{*1}	(min ⁻¹) ^{*1}	CFM ^{*1}	(m ³ /min) ^{*1}	in H ₂ O	(Pa) ^{*1}	(dB) ^{*1}	(g)
4712FL-07W-B40-	X00	48	24.0 ~ 56.0	0.21	10.08	3600	120.0	3.40	0.37	94.2	57.0	240

Rotation: Clockwise

Airflow Outlet: Air Out Over Struts

*1: Average Values in Free Air



General Specifications

Motor Protection:

Auto Restart/Polarity Protection

Insulation Resistance:

10M Ω or over with a DC500V Megger

Dielectric Withstand Voltage: AC 700V 1s

Allowable Ambient Temperature Range:

-10°C ~ +70°C (Operating)

-40°C ~ +70°C (Storage)

(non-condensing environment)

Expected Life

Failure Rate: 10%

25°C 100,000 Hours (P00)

Characteristic Curves

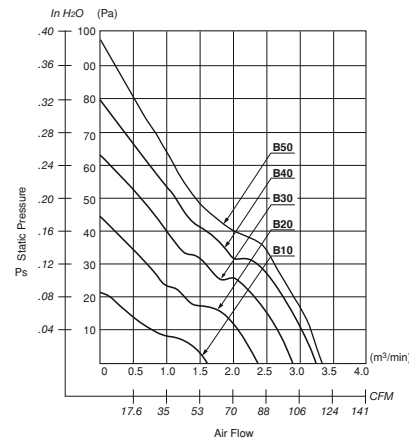

Outline

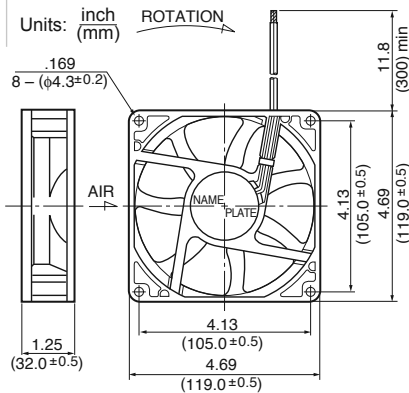

Panel Cut-outs

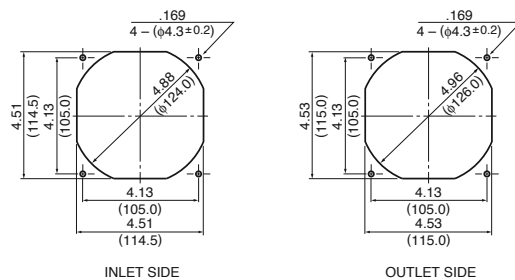

Material

Casing : Plastic (Black) 94V-0

Impeller : Plastic (Black) 94V-0

Bearing : Ball Bearing

Lead Wire: UL1007, AWG24, +Red, -Black

Specifications

MODEL	Product No.	Rated Voltage	Operating Voltage	Current	Input Power	Speed	Max. Air Flow		Max. Static Pressure		Noise	Mass
		(V)	(V)	(A) ^{*1}	(W) ^{*1}	(min ⁻¹) ^{*1}	CFM ^{*1}	(m ³ /min) ^{*1}	in H ₂ O	(Pa) ^{*1}	(dB) ^{*1}	(g)
4712KL-04W-B10-	X00	12	6.0 ~ 13.8	0.16	1.92	1600	56.1	1.59	.09	22.0	29.0	240
4712KL-04W-B20-	X00	12	6.0 ~ 13.8	0.32	3.84	2300	82.2	2.33	.17	42.0	39.0	240
4712KL-04W-B30-	X00	12	6.0 ~ 13.8	0.48	5.76	2800	99.9	2.83	.24	60.0	44.0	240
4712KL-04W-B40-	X00	12	6.0 ~ 13.8	0.69	8.28	3100	112.0	3.17	.33	82.0	47.0	240
4712KL-04W-B50-	X00	12	6.0 ~ 13.8	0.85	10.2	3300	116.4	3.30	.39	98.0	50.5	240
4712KL-05W-B10-	X00	24	12.0 ~ 27.6	0.09	2.16	1600	56.1	1.59	.09	22.0	29.0	240
4712KL-05W-B20-	X00	24	12.0 ~ 27.6	0.17	4.08	2300	82.2	2.33	.17	42.0	39.0	240
4712KL-05W-B30-	X00	24	12.0 ~ 27.6	0.28	6.72	2800	99.9	2.83	.24	60.0	44.0	240
4712KL-05W-B40-	X00	24	12.0 ~ 27.6	0.34	8.16	3100	112.0	3.17	.33	82.0	47.0	240
4712KL-05W-B50-	X00	24	12.0 ~ 27.6	0.41	9.8	3300	116.4	3.30	.39	98.0	50.5	240
4712KL-07W-B10-	X00	48	28.0 ~ 55.2	0.07	3.36	1600	56.1	1.59	.09	22.0	29.0	240
4712KL-07W-B20-	X00	48	28.0 ~ 55.2	0.11	5.28	2300	82.2	2.33	.17	42.0	39.0	240
4712KL-07W-B30-	X00	48	28.0 ~ 55.2	0.16	7.68	2800	99.9	2.83	.24	60.0	44.0	240
4712KL-07W-B40-	X00	48	28.0 ~ 55.2	0.21	10.08	3100	112.0	3.17	.33	82.0	47.0	240

Rotation: Clockwise

Airflow Outlet: Air Out Over Struts

*1: Average Values in Free Air



General Specifications

Motor Protection:

Auto Restart/Polarity Protection

Insulation Resistance:

10M Ω or over with a DC500V Megger

Dielectric Withstand Voltage: AC 700V 1s

Allowable Ambient Temperature Range:

B50 Class: -10°C ~ +40°C (Operating)

B10 ~ B40 Class: -10°C ~ +70°C (Operating)

B10 ~ B40 Class: -40°C ~ +70°C (Storage)

B50 Class: -40°C ~ +60°C (Storage)
(non-condensing environment)

Expected Life

Failure Rate: 10%

25°C 50,000 Hours (P00)

Outline

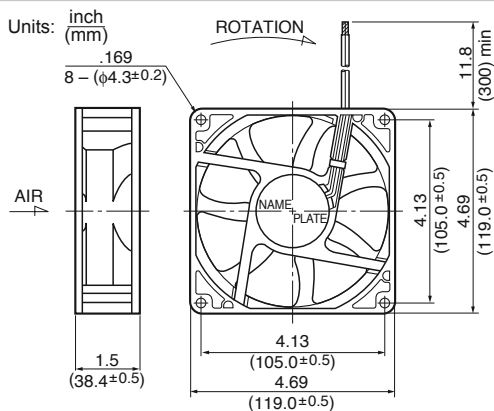

Characteristic Curves

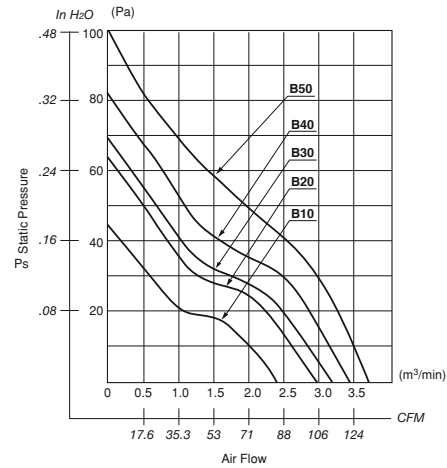

Panel Cut-outs

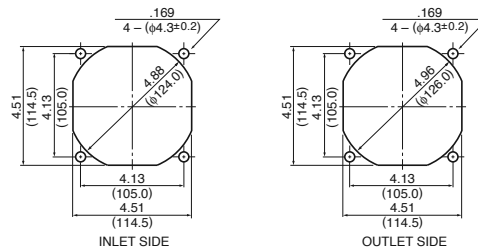

Material

Casing : Plastic (Black) 94V-0

Impeller : Plastic (Black) 94V-0

Bearing : Ball Bearing

Lead Wire : UL1007, AWG24, +Red, -Black

Specifications

MODEL	Product No.	Rated Voltage	Operating Voltage	Current (A) ^{*1}	Input Power (W) ^{*1}	Speed (min ⁻¹) ^{*1}	Max. Air Flow		Max. Static Pressure		Noise (dB) ^{*1}	Mass (g)
		(V)	(V)				CFM ^{*1}	(m ³ /min) ^{*1}	in H ₂ O	(Pa) ^{*1}		
4715KL-04W-B10	X00	12	6.0 ~ 13.8	0.27	3.24	2300	83.6	2.37	.17	44.1	37.0	260
4715KL-04W-B20	X00	12	6.0 ~ 13.8	0.40	4.80	2650	97.0	2.75	.22	55.9	41.0	260
4715KL-04W-B30	X00	12	6.0 ~ 13.8	0.55	6.60	2950	108.0	3.07	.27	68.2	42.5	260
4715KL-04W-B40	X00	12	6.0 ~ 13.8	0.70	8.40	3200	118.0	3.34	.33	81.4	46.5	260
4715KL-04W-B50	X00	12	9.5 ~ 12.6	1.00	12.00	3600	129.9	3.68	.44	110.0	50.0	260
4715KL-05W-B10	X00	24	10.0 ~ 27.6	0.15	3.60	2300	83.6	2.37	.17	44.1	37.0	260
4715KL-05W-B20	X00	24	10.0 ~ 27.6	0.21	5.04	2650	97.0	2.75	.22	55.9	41.0	260
4715KL-05W-B30	X00	24	10.0 ~ 27.6	0.31	7.44	2950	108.0	3.07	.27	68.2	42.5	260
4715KL-05W-B40	X00	24	10.0 ~ 27.6	0.35	8.40	3200	118.0	3.34	.33	81.4	46.5	260
4715KL-05W-B50	X00	24	18.0 ~ 25.0	0.50	12.00	3600	130.0	3.68	.44	110.0	50.0	260
4715KL-07W-B10	X00	48	25.0 ~ 55.2	0.08	3.84	2300	83.6	2.37	.17	44.1	37.0	260
4715KL-07W-B20	X00	48	25.0 ~ 55.2	0.11	5.28	2650	97.0	2.75	.22	55.9	41.0	260
4715KL-07W-B30	X00	48	25.0 ~ 55.2	0.16	7.68	2950	108.0	3.07	.27	68.2	42.5	260
** 4715KL-07W-B40	X00	48	25.0 ~ 55.2	0.20	9.60	3200	118.0	3.34	.33	81.4	46.5	260
4715KL-07W-B50	X00	48	30.0 ~ 60.0	0.16	7.68	3600	130.0	3.68	.44	110.0	50.0	260

Rotation: Clockwise

Airflow Outlet: Air Out Over Struts

*1: Average Values in Free Air

** Contact NMB for availability



General Specifications

Motor Protection:

Auto Restart/Polarity Protection

Insulation Resistance:

10M Ω or over with a DC500V Megger

Dielectric Withstand Voltage: AC 700V 1s

Allowable Ambient Temperature Range:

B50, B40 Class: -10°C ~ +45°C (Operating)

B30 Class: -10°C ~ +50°C (Operating)

All Class: -40°C ~ +60°C (Storage)

(non-condensing environment)

Expected Life

Failure Rate: 10%

25°C 100,000 Hours (R00)

Outline

Units: $\frac{\text{inch}}{\text{mm}}$

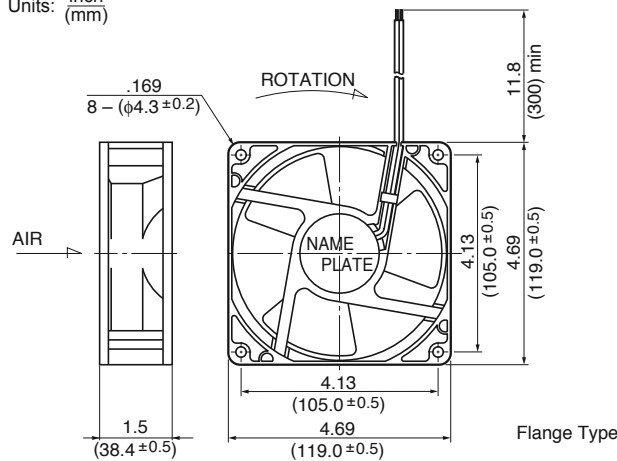

Characteristic Curves

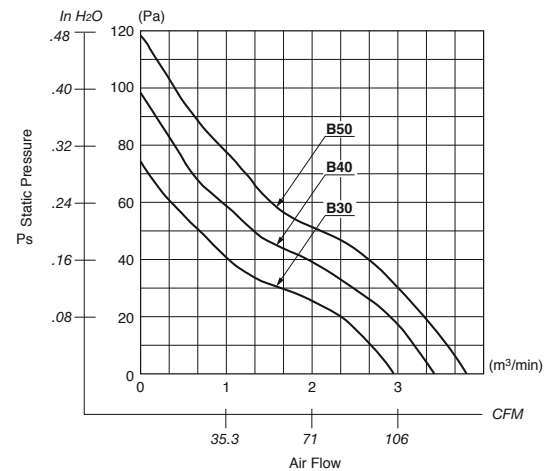

Panel Cut-outs

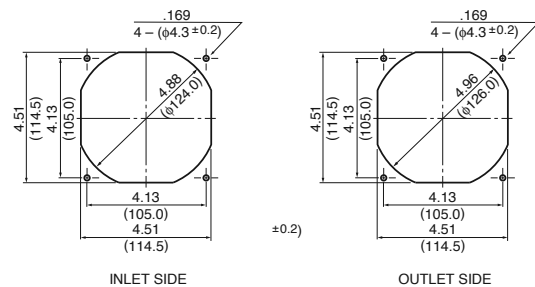

Material

- Casing : Plastic (Black) 94V-0
- Impeller : Plastic (Black) 94V-0
- Bearing : Ball Bearing
- Lead Wire : UL1007, AWG24, +Red, -Black

Specifications

MODEL	Product No.	Rated Voltage	Operating Voltage	Current	Input Power	Speed	Max. Air Flow		Max. Static Pressure		Noise	Mass
		(V)	(V)	(A) ^{*1}	(W) ^{*1}	(min ⁻¹) ^{*1}	CFM ^{*1}	(m ³ /min) ^{*1}	in H ₂ O	(Pa) ^{*1}	(dB) ^{*1}	(g)
4715KL-04W-B50-	R00	12	9.5 ~ 12.6	0.85	10.2	3900	132.0	3.73	.45	113.0	54.0	260
4715KL-05W-B50-	R00	24	20.0 ~ 25.0	0.48	11.5	3900	132.0	3.73	.45	113.0	54.0	260
** 4715KL-07W-B30-	R00	48	25.0 ~ 55.2	0.13	6.24	3100	105.0	2.97	.30	74.0	47.0	260
** 4715KL-07W-B40-	R00	48	25.0 ~ 50.4	0.16	7.68	3500	121.0	3.44	.39	97.5	51.0	260
** 4715KL-07W-B50-	R00	48	36.0 ~ 50.0	0.20	9.60	3900	132.0	3.73	.45	113.0	54.0	260

Rotation: Clockwise

Airflow Outlet: Air Out Over Struts

*1: Average Values in Free Air

** Contact NMB for availability



General Specifications

Motor Protection:

Auto Restart/Polarity Protection

Insulation Resistance:

10M Ω or over with a DC500V Megger

Dielectric Withstand Voltage: AC 700V 1s

Allowable Ambient Temperature Range:

B20 ~ B70 Class: -10°C ~ +70°C (Operating)

B90 Class: -10°C ~ +60°C (Storage)

All Class: -40°C ~ +60°C (Storage)
(non-condensing environment)

Expected Life

Failure Rate: 10%

25°C 100,000 Hours (D00)

Characteristic Curves

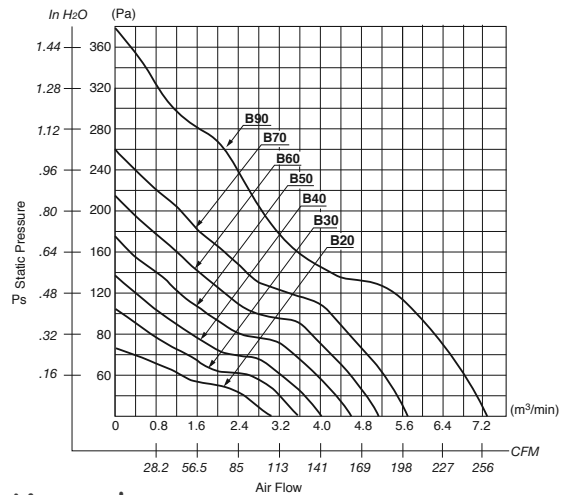

Outline

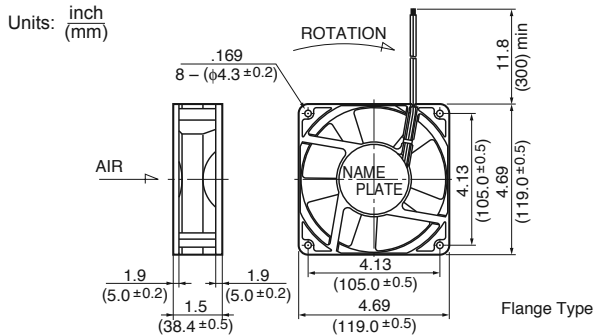

Material

Casing : Plastic (Black) 94V-0

Impeller : Plastic (Black) 94V-0

Bearing : Ball Bearing

Lead Wire : UL1007, AWG24, +Red, -Black

Specifications

MODEL	Rated Voltage	Operating Voltage	Current	Input Power	Speed	Max. Air Flow		Max. Static Pressure		Noise	Mass	
						CFM ^{*1}	(m ³ /min) ^{*1}	in H ₂ O	(Pa) ^{*1}			
4715SL-04W-B20-	D00	12	8.0 ~ 13.8	.48	5.76	2700	102.7	2.91	.30	76.0	45.0	400
4715SL-04W-B30-	D00	12	8.0 ~ 13.8	.66	7.92	3200	122.1	3.46	.40	102.0	49.5	400
4715SL-04W-B40-	D00	12	8.0 ~ 13.8	1.00	12.00	3700	141.9	4.02	.54	136.0	53.5	400
4715SL-04W-B50-	D00	12	8.0 ~ 13.2	1.46	17.50	4200	162.0	4.59	.69	173.0	56.5	400
4715SL-04W-B60-	D00	12	8.0 ~ 12.9	1.92	23.00	4700	181.0	5.13	.85	213.0	59.5	400
4715SL-04W-B70-	D00	12	8.0 ~ 12.6	3.20	38.40	5100	201.0	5.69	1.04	260.5	62.3	400
4715SL-05W-B20-	D00	24	15.0 ~ 27.6	0.26	6.24	2700	102.7	2.91	.30	76.0	45.0	400
4715SL-05W-B30-	D00	24	15.0 ~ 27.6	0.35	8.40	3200	122.1	3.46	.40	102.0	49.5	400
4715SL-05W-B40-	D00	24	15.0 ~ 27.6	0.52	12.50	3700	141.9	4.02	.54	136.0	53.5	400
4715SL-05W-B50-	D00	24	15.0 ~ 27.6	0.74	17.80	4200	162.0	4.59	.69	173.0	56.5	400
4715SL-05W-B60-	D00	24	15.0 ~ 26.4	0.93	22.40	4700	181.0	5.13	.85	213.0	59.5	400
4715SL-05W-B70-	D00	24	15.0 ~ 25.2	1.50	36.00	5100	201.0	5.69	1.04	260.5	62.3	400
4715SL-07W-B40-	D00	48	30.0 ~ 55.2	0.27	13.00	3700	141.9	4.02	.54	136.0	53.5	400
4715SL-07W-B50-	D00	48	30.0 ~ 55.2	0.37	17.80	4200	162.0	4.59	.69	173.0	56.5	400
4715SL-07W-B60-	D00	48	30.0 ~ 52.8	0.49	23.50	4700	181.0	5.13	.85	213.0	59.5	400
4715SL-07W-B70-	D00	48	30.0 ~ 50.4	0.83	39.84	5100	201.0	5.69	1.04	260.5	62.3	400
4715SL-07W-B90-	D00	48	30.0 ~ 53.0	1.10	52.80	6000	257.6	7.30	1.44	360.0	65.5	400

Rotation: Clockwise

Airflow Outlet: Air Out Over Struts

*1: Average Values in Free Air

** Contact NMB for availability

† Not available in the USA



General Specifications

Motor Protection:

Auto Restart/Polarity Protection

Insulation Resistance:

10M Ω or over with a DC500V Megger

Dielectric Withstand Voltage: AC 700V 1s

Allowable Ambient Temperature Range:

-20°C ~ +40°C (65%RH) (Operating)

-40°C ~ +70°C (65%RH) (Storage)

(non-condensing environment)

Expected Life

Failure Rate: 10%

50,000 Hours (25°C, 65%RH)

Outline

Units: $\frac{\text{inch}}{\text{mm}}$

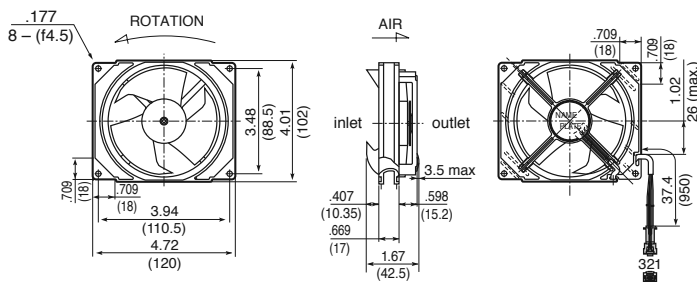

Housing with solid corner type are available.

Characteristic Curves

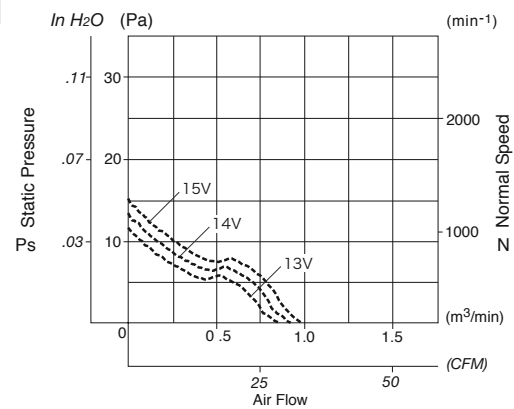

Panel Cut-outs

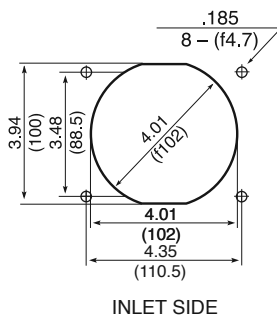

INLET SIDE

Material

Bearing : Hydro Wave

Specifications

MODEL	Rated Voltage	Operating Voltage	Current	Input Power	Rated Speed	Max. Air Flow		Max. Static Pressure		Noise	Mass
	(V)	(V)	(A) ^{*1}	(W) ^{*1}	(min ⁻¹) ^{*1}	CFM ^{*1}	(m ³ /min) ^{*1}	in H ₂ O	(Pa) ^{*1}	(dB) ^{*1}	(g)
FBA10B14L	14	7.0 ~ 15.0	85	1.19	1750	32.1	0.91	.06	15.0	24.0	150

Rotation: Clockwise

Airflow Outlet: Air Out Over Struts

*1: Average Values in Free Air



General Specifications

Motor Protection:

Auto Restart/Polarity Protection

Insulation Resistance:

10M Ω or over with a DC500V Megger

Dielectric Withstand Voltage: AC 700V 1s

Allowable Ambient Temperature Range:

FBA11J10M

-40°C ~ +40°C (65%RH) (Operating)

-40°C ~ +70°C (65%RH) (Storage)

(non-condensing environment)

FBA11J14L

-20°C ~ +40°C (65%RH) (Operating)

-40°C ~ +70°C (65%RH) (Storage)

(non-condensing environment)

Expected Life

FBA11J10M

Failure Rate: 10%

70,000 Hours (-30°C)

FBA11J14L

Failure Rate: 10%

70,000 Hours (-10°C)

Outline

Units: inch (mm)

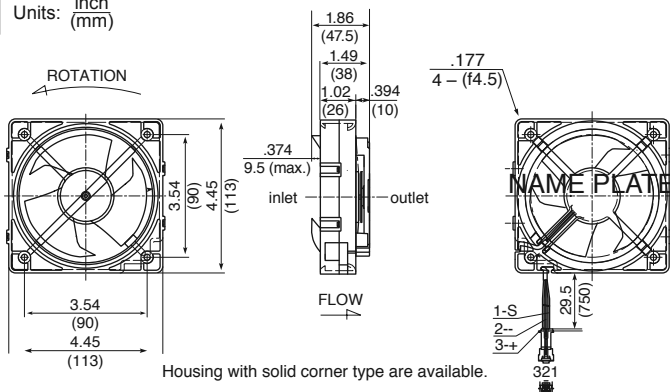

Characteristic Curves

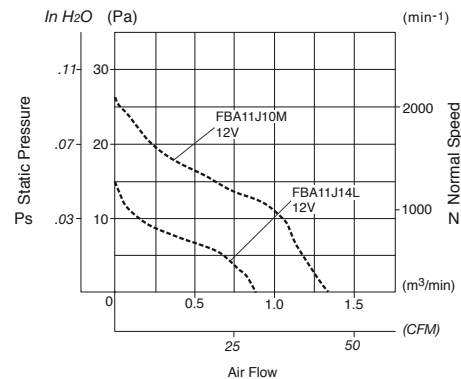

Panel Cut-outs

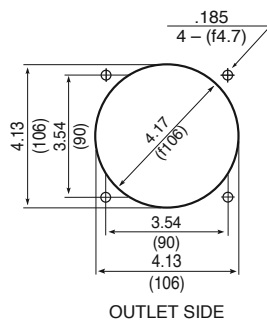

Material

Bearing : Hydro Wave Bearing

Specifications

MODEL	Rated Voltage	Operating Voltage	Current	Input Power	Rated Speed	Max. Air Flow		Max. Static Pressure		Noise	Mass
	(V)	(V)	(A) ^{*1}	(W) ^{*1}	(min ⁻¹) ^{*1}	CFM ^{*1}	(m ³ /min) ^{*1}	in H ₂ O	(Pa) ^{*1}	(dB) ^{*1}	(g)
FBA11J10M	9	7.0 ~ 14.0	102	0.92	1920	36.0	1.02	.06	17.0	24.0	180
FBA11J14L	14	7.0 ~ 14.0	63	0.88	2100	39.5	1.12	.08	21.0	25.0	185

Rotation: Clockwise

Airflow Outlet: Air Out Over Struts

*1: Average Values in Free Air



General Specifications

Motor Protection:

Auto Restart/Polarity Protection

Insulation Resistance:

10M Ω or over with a DC500V Megger

Dielectric Withstand Voltage: AC 700V 1s

Allowable Ambient Temperature Range:

-40°C ~ +40°C (65%RH) (Operating)

-40°C ~ +70°C (65%RH) (Storage)

(non-condensing environment)

Expected Life

Failure Rate: 10%

-20°C 40,000 Hours

Outline

Units: $\frac{\text{inch}}{\text{mm}}$

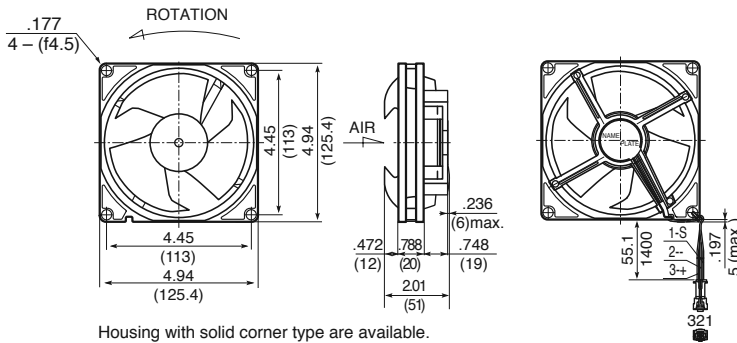

Housing with solid corner type are available.

Characteristic Curves

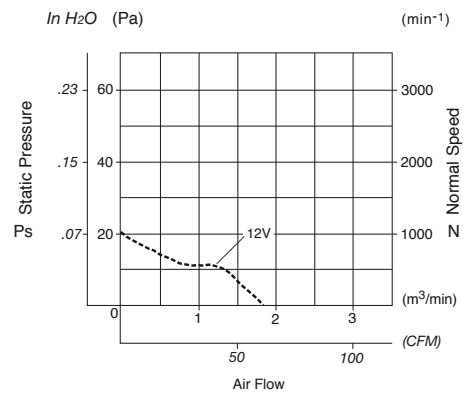

Panel Cut-outs

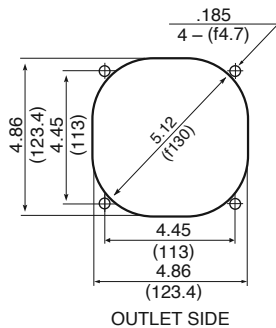

OUTLET SIDE

Material

Bearing : Hydro Wave Bearing

Specifications

MODEL	Rated Voltage	Operating Voltage	Current	Input Power	Rated Speed	Max. Air Flow		Max. Static Pressure		Noise	Mass
	(V)	(V)	(A) ^{*1}	(W) ^{*1}	(min ⁻¹) ^{*1}	CFM ^{*1}	(m ³ /min) ^{*1}	in H ₂ O	(Pa) ^{*1}	(dB) ^{*1}	(g)
FBA12J12M	12	7.0 ~ 14.0	235	2.82	2000	65.3	1.85	.09	24.0	32.0	190

Rotation: Clockwise

Airflow Outlet: Air Out Over Struts

*1: Average Values in Free Air



General Specifications

Motor Protection:

Auto Restart/Polarity Protection

Insulation Resistance:

10M Ω or over with a DC500V Megger

Dielectric Withstand Voltage: AC 700V 1s

Allowable Ambient Temperature Range:

B50 Class: -10°C ~ +60°C (Operating)

B10 ~ B40 Class: -10°C ~ +70°C (Operating)

All Class: -40°C ~ +70°C (Storage)

(non-condensing environment)

Expected Life

Failure Rate: 10%

25°C 100,000 Hours (E00)

Characteristic Curves

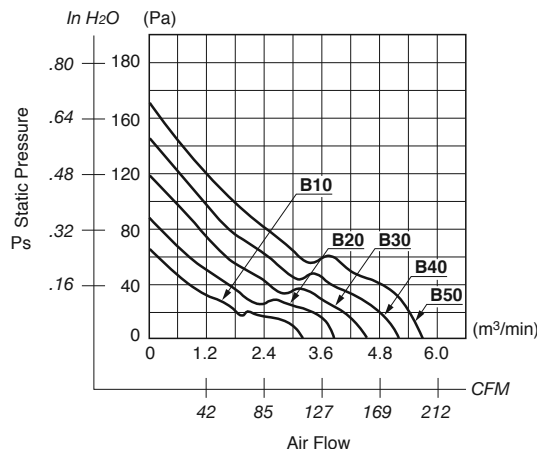

Outline

Units: inch (mm)

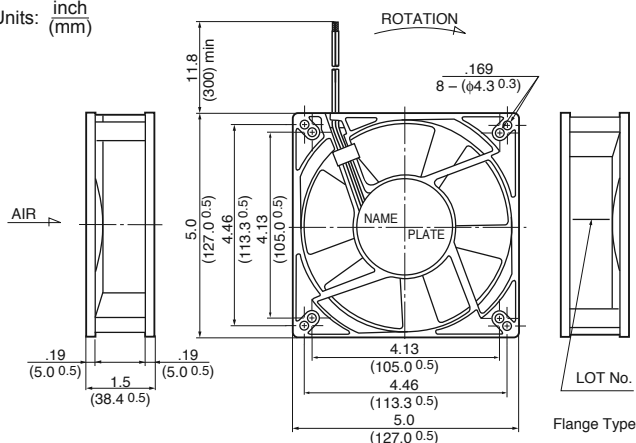

Panel Cut-outs

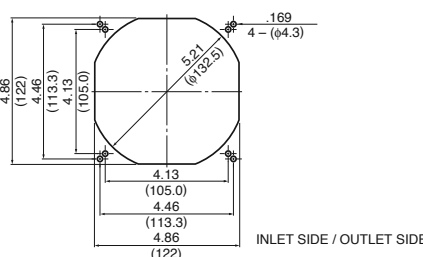

Material

Casing : Plastic (Black) 94V-0

Impeller : Plastic (Black) 94V-0

Bearing : Ball Bearing

Lead Wire : UL1007, AWG24, +Red, -Black

Specifications

MODEL	Product No.	Rated Voltage	Operating Voltage	Current (A) ^{*1}	Input Power (W) ^{*1}	Speed (min ⁻¹) ^{*1}	Max. Air Flow		Max. Static Pressure		Noise (dB) ^{*1}	Mass (g)
		(V)	(V)				CFM ^{*1}	(m ³ /min) ^{*1}	in H ₂ O	(Pa) ^{*1}		
** 5015KL-04W-B10-	E00	12	8.0 ~ 13.8	0.48	5.76	2600	115.0	3.26	.25	64.1	45.5	360
** 5015KL-04W-B20-	E00	12	8.0 ~ 13.8	0.72	8.64	3100	139.0	3.94	.36	89.7	50.5	360
** 5015KL-04W-B30-	E00	12	8.0 ~ 13.8	0.98	11.76	3600	163.0	4.62	.48	119.7	55.0	360
** 5015KL-04W-B40-	E00	12	8.0 ~ 13.8	1.44	17.28	4000	180.0	5.11	.59	147.8	57.5	360
** 5015KL-04W-B50-	E00	12	8.0 ~ 13.2	2.04	24.48	4400	199.0	5.64	.71	176.5	60.5	360
** 5015KL-05W-B10-	E00	24	18.0 ~ 27.6	0.22	5.28	2600	115.0	3.26	.25	64.1	45.5	360
** 5015KL-05W-B20-	E00	24	18.0 ~ 27.6	0.34	8.16	3100	139.0	3.94	.36	89.7	50.5	360
** 5015KL-05W-B30-	E00	24	18.0 ~ 27.6	0.51	12.24	3600	163.0	4.62	.48	119.7	55.0	360
** 5015KL-05W-B40-	E00	24	18.0 ~ 27.6	0.68	16.32	4000	180.0	5.11	.59	147.8	57.5	360
** 5015KL-05W-B50-	E00	24	18.0 ~ 26.4	0.90	21.60	4400	199.0	5.64	.71	176.5	60.5	360
** 5015KL-07W-B10-	E00	48	36.0 ~ 55.2	0.17	8.16	2600	115.0	3.26	.25	64.1	45.5	360
** 5015KL-07W-B20-	E00	48	36.0 ~ 55.2	0.23	11.04	3100	139.0	3.94	.36	89.7	50.5	360
** 5015KL-07W-B30-	E00	48	36.0 ~ 55.2	0.33	15.84	3600	163.0	4.62	.48	119.7	55.0	360
** 5015KL-07W-B40-	E00	48	36.0 ~ 55.2	0.38	18.24	4000	180.0	5.11	.59	147.8	57.5	360
** 5015KL-07W-B50-	E00	48	36.0 ~ 52.8	0.45	21.60	4400	199.0	5.64	.71	176.5	60.5	360

Rotation: Clockwise

Airflow Outlet: Air Out Over Struts

*1: Average Values in Free Air

** Contact NMB for availability



General Specifications

Motor Protection:

Auto Restart/Polarity Protection

Insulation Resistance:

10M Ω or over with a DC500V Megger

Dielectric Withstand Voltage: AC 700V 1s

Allowable Ambient Temperature Range:

Under Study (Operating)

-40°C ~ +70°C (Storage)

(non-condensing environment)

Expected Life

Failure Rate: 10%

Outline

Units: $\frac{\text{inch}}{\text{mm}}$

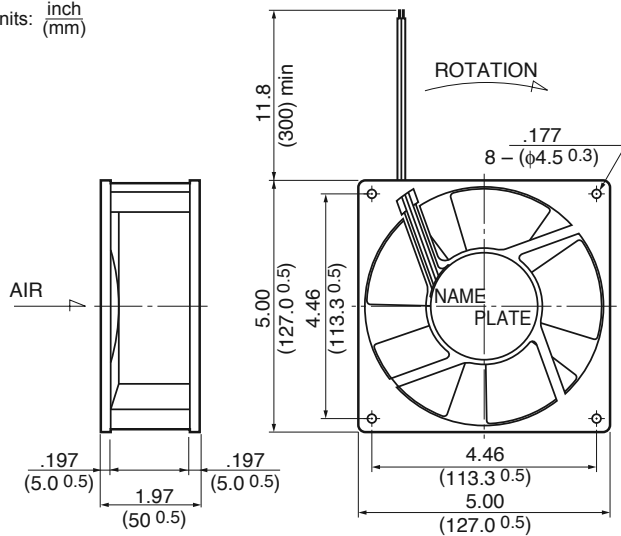

Characteristic Curves

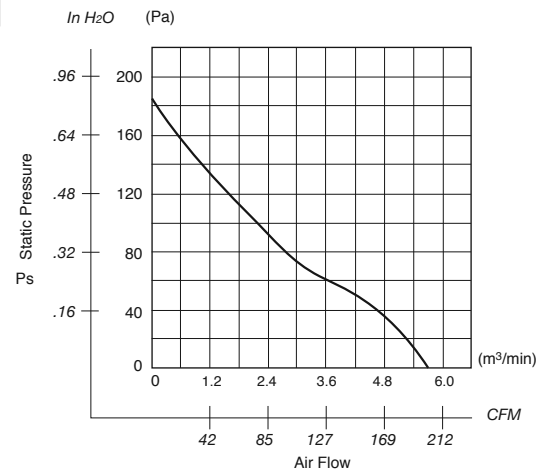

Panel Cut-outs

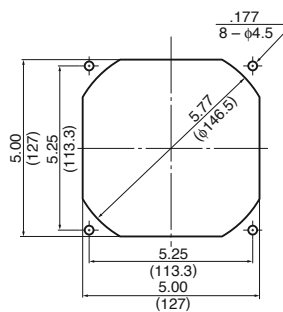

INLET SIDE / OUTLET SIDE

Material

Casing : Plastic (Black) 94V-0

Impeller : Plastic (Black) 94V-0

Bearing : Ball Bearing

Lead Wire: UL1007, AWG24, +Red, -Black

Specifications

MODEL	Product No.	Rated Voltage	Operating Voltage	Current	Input Power	Speed	Max. Air Flow		Max. Static Pressure		Noise	Mass
		(V)	(V)	(A) ^{*1}	(W) ^{*1}	(min ⁻¹) ^{*1}	CFM ^{*1}	(m ³ /min) ^{*1}	in H ₂ O	(Pa) ^{*1}	(dB) ^{*1}	(g)
** 5020KL-04W-B50-	P00	12	6.0 ~ 12.6	2.40	28.8	4400	198.7	5.63	.76	189.8	57	390

Rotation: Clockwise

Airflow Outlet: Air Out Over Struts

*1: Average Values in Free Air

** Contact NMB for availability



General Specifications

Motor Protection:

Circuit Protection (limit current)

Insulation Resistance:

10M Ω or over with a DC500V

Dielectric Withstand Voltage: AC 50/60Hz 500V 1min

Allowable Ambient Temperature Range:

-10°C ~ +60°C (No Dew) (Operating)
(non-condensing environment)

Expected Life

Failure Rate: 10%

100,000 Hours (40°C. 65%RH)

Outline

Units: $\frac{\text{inch}}{\text{mm}}$

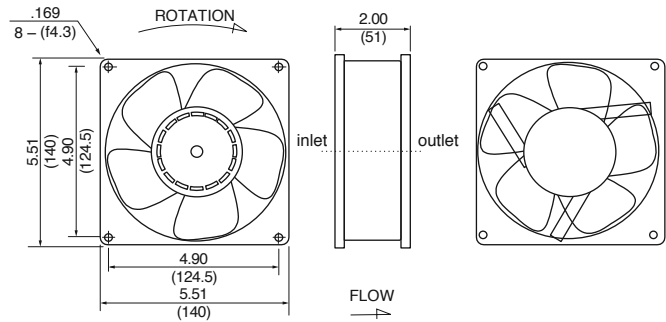

Characteristic Curves

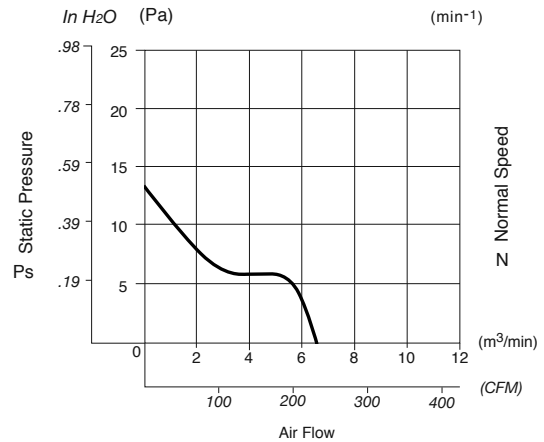

Panel Cut-outs

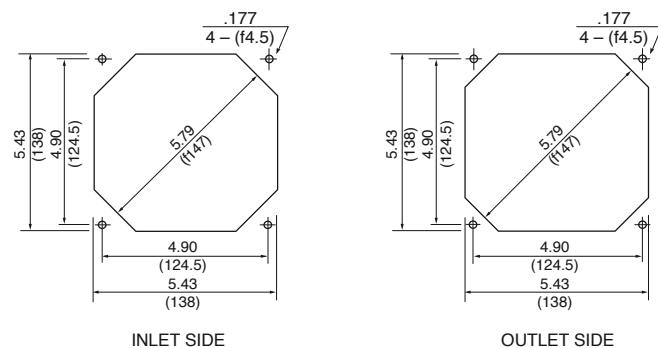

Material

- Casing : Aluminum
- Impeller : Plastic (Black) 94V-0
- Bearing : Ball Bearing
- Lead Wire: UL1007, AWG24, +Red, -Black

Specifications

MODEL	Rated Voltage	Operating Voltage	Current	Input Power	Speed	Max. Air Flow		Max. Static Pressure		Noise	Mass
	(V)	(V)	(A) ^{*1}	(W) ^{*1}	(min ⁻¹) ^{*1}	CFM ^{*1}	(m ³ /min) ^{*1}	in H ₂ O	(Pa) ^{*1}	(dB) ^{*1}	(g)
FBX14 L48	48	40.8 ~ 55.2	.27	13.0	2900	219.0	6.2	.55	138.0	52.0	500

Rotation: Clockwise

Airflow Outlet: Air Out Over Struts

*1: Average Values in Free Air

General Specifications

Motor Protection:

Auto Restart/Polarity Protection

Insulation Resistance:

10M Ω or over with a DC500V Megger

Dielectric Withstand Voltage: AC 700V 1s

Allowable Ambient Temperature Range:

-10°C ~ +70°C (Operating)

-40°C ~ +70°C (Storage)

(non-condensing environment)

Expected Life

Failure Rate: 10%

25°C 100,000 Hours (L00)

Outline

Units: $\frac{\text{inch}}{\text{mm}}$

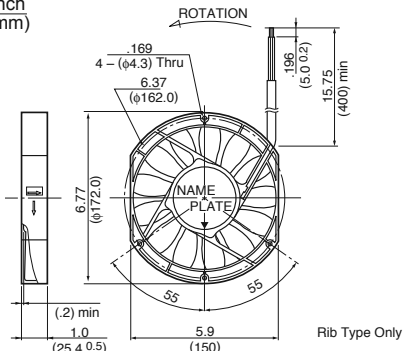

Characteristic Curves

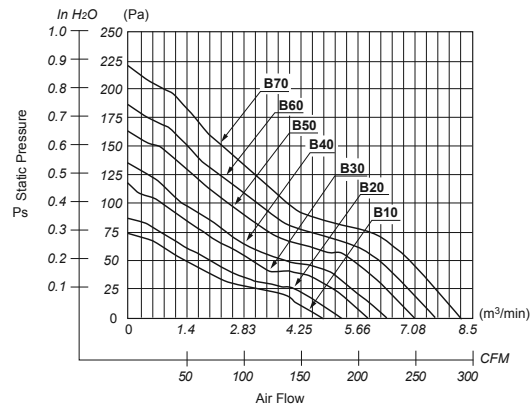

Panel Cut-outs

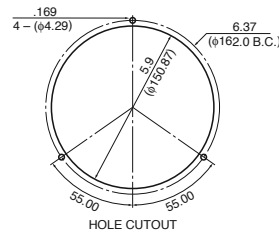

Material

Casing : Aluminum (Black)

Impeller : Plastic (Black) 94V-0

Bearing : Ball Bearing

Lead Wire : UL1007, AWG22, +Red, -Black

Specifications

MODEL	Product No.	Rated Voltage	Operating Voltage	Current	Input Power	Speed	Max. Air Flow		Max. Static Pressure		Noise	Mass
		(V)	(V)	(A)*1	(W)*1	(min ⁻¹)*1	CFM*1	(m ³ /min)*1	in H ₂ O	(Pa)*1	(dB)*1	(g)
5910PL-04W-B10-	L00	12	7.0 ~ 18.0	0.81	9.72	2500	158.8	4.50	.26	67.0	52.7	545
** 5910PL-04W-B20-	L00	12	7.0 ~ 18.0	1.17	14.04	2850	183.5	5.20	.34	85.0	55.5	545
5910PL-04W-B30-	L00	12	7.0 ~ 18.0	1.56	18.72	3150	204.7	5.80	.41	104.0	58.9	545
** 5910PL-04W-B40-	L00	12	7.0 ~ 18.0	1.67	20.04	3350	218.8	6.20	.47	118.0	60.2	545
5910PL-04W-B50-	L00	12	7.0 ~ 18.0	1.85	22.20	3500	225.9	6.40	.58	145.0	61.4	545
** 5910PL-05W-B10-	L00	24	12.5 ~ 30.0	0.41	9.84	2500	158.8	4.50	.26	67.0	52.7	545
** 5910PL-05W-B20-	L00	24	12.5 ~ 30.0	0.51	12.24	2850	183.5	5.20	.34	85.0	55.5	545
5910PL-05W-B30-	L00	24	12.5 ~ 30.0	0.67	16.08	3150	204.7	5.80	.41	104.0	58.9	545
5910PL-05W-B40-	L00	24	12.5 ~ 30.0	0.81	19.40	3350	218.8	6.20	.47	118.0	60.2	545
5910PL-05W-B50-	L00	24	12.5 ~ 30.0	0.87	20.90	3500	225.9	6.40	.58	145.0	61.4	545
5910PL-05W-B60-	L00	24	12.5 ~ 30.0	1.10	26.40	3750	241.8	6.85	.68	170.0	63.7	545
5910PL-05W-B70-	L00	24	12.5 ~ 30.0	1.40	33.60	4100	268.2	7.60	.81	203.0	65.2	545
5910PL-07W-B10-	L00	48	25.0 ~ 60.0	0.22	10.56	2500	158.8	4.50	.26	67.0	52.7	545
5910PL-07W-B20-	L00	48	25.0 ~ 60.0	0.28	13.44	2850	183.5	5.20	.34	85.0	55.5	545
5910PL-07W-B30-	L00	48	25.0 ~ 60.0	0.36	17.28	3150	204.7	5.80	.41	104.0	58.9	545
5910PL-07W-B40-	L00	48	25.0 ~ 60.0	0.39	18.72	3350	218.8	6.20	.47	118.0	60.2	545
5910PL-07W-B50-	L00	48	25.0 ~ 60.0	0.45	21.60	3500	225.9	6.40	.58	145.0	61.4	545
5910PL-07W-B60-	L00	48	25.0 ~ 60.0	0.55	26.40	3750	241.8	6.85	.68	170.0	63.7	545
5910PL-07W-B70-	L00	48	25.0 ~ 60.0	0.70	33.60	4100	268.2	7.60	.81	203.0	65.2	545

Rotation: Clockwise

Airflow Outlet: Air Out Over Struts

*1: Average Values in Free Air

** Contact NMB for availability



General Specifications

Motor Protection:

Auto Restart/Polarity Protection

Insulation Resistance:

10M Ω or over with a DC500V Megger

Dielectric Withstand Voltage: AC 700V 1s

Allowable Ambient Temperature Range:

-10°C ~ +70°C (Operating)

-40°C ~ +70°C (Storage)

(non-condensing environment)

Expected Life

Failure Rate: 10%

25°C 100,000 Hours (D00)

Outline

Units: $\frac{\text{inch}}{\text{mm}}$

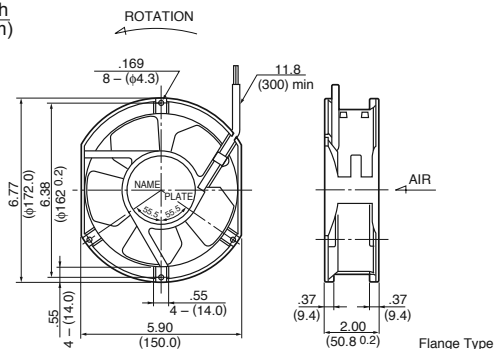

Characteristic Curves

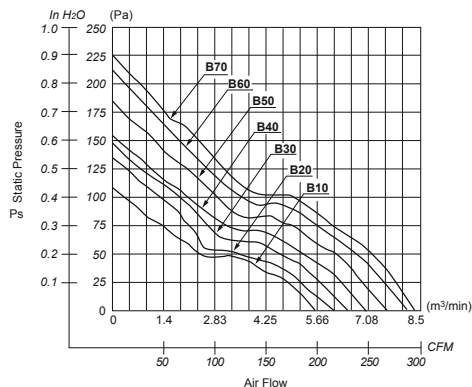

Panel Cut-outs

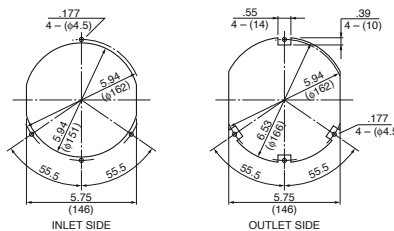

Material

Casing : Aluminum (Black)

Impeller : Plastic (Black) 94V-0

Bearing : Ball Bearing

Lead Wire : UL1007, AWG22, +Red, -Black

Specifications

MODEL	Product No.	Rated Voltage	Operating Voltage	Current	Input Power	Speed	Max. Air Flow		Max. Static Pressure		Noise	Mass
		(V)	(V)	(A) ^{*1}	(W) ^{*1}	(min ⁻¹) ^{*1}	CFM ^{*1}	(m ³ /min) ^{*1}	in H ₂ O	(Pa) ^{*1}	(dB) ^{*1}	(g)
5920PL-04W-B10	D00	12	6.0 ~ 14.0	1.10	13.20	2550	180.0	5.10	.38	94.1	52.0	830
5920PL-04W-B20	D00	12	6.0 ~ 14.0	1.50	18.00	2850	199.4	5.65	.47	117.7	55.0	830
5920PL-04W-B30	D00	12	6.0 ~ 14.0	1.90	22.80	3150	225.9	6.40	.57	141.2	58.0	830
5920PL-04W-B40	D00	12	6.0 ~ 14.0	2.20	26.40	3350	240.0	6.80	.63	155.9	60.0	830
** 5920PL-04W-B50	D00	12	6.0 ~ 18.0	1.60	19.20	3500	260.0	7.36	.73	182.7	60.3	830
5920PL-05W-B10	D00	24	18.0 ~ 28.0	0.50	12.00	2550	180.0	5.10	.38	94.1	52.0	830
5920PL-05W-B20	D00	24	18.0 ~ 28.0	0.63	15.12	2850	199.4	5.65	.47	117.7	55.0	830
5920PL-05W-B30	D00	24	18.0 ~ 28.0	0.80	19.20	3150	225.9	6.40	.57	141.2	58.0	830
5920PL-05W-B40	D00	24	18.0 ~ 28.0	0.95	22.80	3350	240.0	6.80	.63	155.9	60.0	830
** 5920PL-05W-B50	D00	24	12.0 ~ 30.0	0.79	18.96	3500	260.0	7.36	.73	182.7	60.3	830
** 5920PL-05W-B60	D00	24	12.0 ~ 30.0	0.88	21.12	3750	280.0	7.93	.84	210.5	62.5	830
5920PL-05W-B70	D00	24	12.0 ~ 30.0	1.08	25.92	4000	300.0	8.50	.90	226.5	63.2	830
5920PL-07W-B10	D00	48	36.0 ~ 56.0	0.26	12.48	2550	180.0	5.10	.38	94.1	52.0	830
5920PL-07W-B20	D00	48	36.0 ~ 56.0	0.33	15.84	2850	199.4	5.65	.47	117.7	55.0	830
5920PL-07W-B30	D00	48	36.0 ~ 56.0	0.40	19.20	3150	225.9	6.40	.57	141.2	58.0	830
5920PL-07W-B40	D00	48	36.0 ~ 56.0	0.45	21.60	3350	240.0	6.80	.63	155.9	60.0	830
** 5920PL-07W-B50	D00	48	25.0 ~ 60.0	0.40	19.20	3500	260.0	7.36	.73	182.7	60.3	830
** 5920PL-07W-B60	D00	48	25.0 ~ 60.0	0.47	22.56	3750	280.0	7.93	.84	210.5	62.5	830
5920PL-07W-B70	D00	48	25.0 ~ 60.0	0.51	24.48	4000	300.0	8.50	.90	226.5	63.2	830

Rotation: Clockwise

Airflow Outlet: Air Out Over Struts

*1: Average Values in Free Air

** Contact NMB for availability



General Specifications

Motor Protection:

Auto Restart/Polarity Protection

Insulation Resistance:

10M Ω or over with a DC500V Megger

Dielectric Withstand Voltage: AC 700V 1s

Allowable Ambient Temperature Range:

-10°C ~ +70°C (Operating)

-40°C ~ +70°C (Storage)

(non-condensing environment)

Expected Life

Failure Rate: 10%

25°C 100,000 Hours (D00)

Outline

Units: $\frac{\text{inch}}{\text{mm}}$

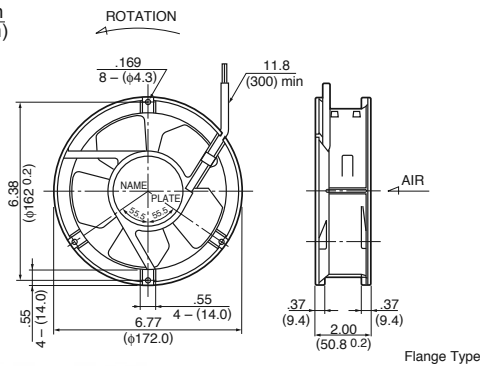

Characteristic Curves

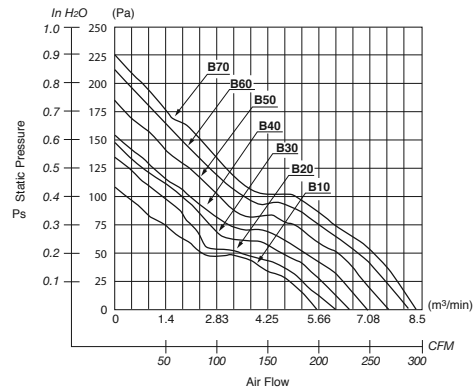

Panel Cut-outs

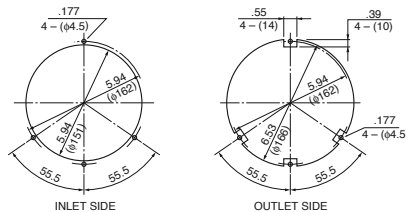

Material

Casing : Aluminum (Black)

Impeller : Plastic (Black) 94V-0

Bearing : Ball Bearing

Lead Wire : UL1007, AWG22, +Red, -Black

Specifications

MODEL	Product No.	Rated Voltage	Operating Voltage	Current	Input Power	Speed	Max. Air Flow		Max. Static Pressure		Noise	Mass
		(V)	(V)	(A) ^{*1}	(W) ^{*1}	(min ⁻¹) ^{*1}	CFM ^{*1}	(m ³ /min) ^{*1}	in H ₂ O	(Pa) ^{*1}	(dB) ^{*1}	(g)
6820PL-04W-B10	D00	12	6.0 ~ 14.0	1.10	13.20	2550	180.0	5.10	.38	94.1	50.0	830
6820PL-04W-B20	D00	12	6.0 ~ 14.0	1.50	18.00	2850	199.4	5.65	.47	117.7	53.0	830
6820PL-04W-B30	D00	12	6.0 ~ 14.0	1.90	22.80	3150	225.9	6.40	.57	141.2	55.0	830
6820PL-04W-B40	D00	12	6.0 ~ 14.0	2.20	26.40	3350	240.0	6.80	.63	155.9	58.0	830
** 6820PL-04W-B50	D00	12	6.0 ~ 18.0	1.60	19.20	3500	260.0	7.36	.73	182.7	60.3	830
6820PL-05W-B10	D00	24	18.0 ~ 28.0	0.50	12.00	2550	180.0	5.10	.38	94.1	50.0	830
6820PL-05W-B20	D00	24	18.0 ~ 28.0	0.63	15.12	2850	199.4	5.65	.47	117.7	53.0	830
6820PL-05W-B30	D00	24	18.0 ~ 28.0	0.80	19.20	3150	225.9	6.40	.57	141.2	55.0	830
6820PL-05W-B40	D00	24	18.0 ~ 28.0	0.95	22.80	3350	240.0	6.80	.63	155.9	58.0	830
** 6820PL-05W-B50	D00	24	12.0 ~ 30.0	0.79	18.96	3500	260.0	7.36	.73	182.7	60.3	830
** 6820PL-05W-B60	D00	24	12.0 ~ 30.0	0.88	21.12	3750	280.0	7.93	.84	210.5	62.5	830
** 6820PL-05W-B70	D00	24	12.0 ~ 30.0	1.08	25.92	4000	300.0	8.50	.90	226.5	63.2	830
6820PL-07W-B10	D00	48	36.0 ~ 56.0	0.26	12.48	2550	180.0	5.10	.38	94.1	50.0	830
6820PL-07W-B20	D00	48	36.0 ~ 56.0	0.33	15.84	2850	199.4	5.65	.47	117.7	53.0	830
6820PL-07W-B30	D00	48	36.0 ~ 56.0	0.40	19.20	3150	225.9	6.40	.57	141.2	55.0	830
6820PL-07W-B40	D00	48	36.0 ~ 56.0	0.45	21.60	3350	240.0	6.80	.63	155.9	58.0	830
** 6820PL-07W-B50	D00	48	25.0 ~ 60.0	0.40	19.20	3500	260.0	7.36	.73	182.7	60.3	830
** 6820PL-07W-B60	D00	48	25.0 ~ 60.0	0.47	22.56	3750	280.0	7.93	.84	210.5	62.5	830
** 6820PL-07W-B70	D00	48	25.0 ~ 60.0	0.51	24.48	4000	300.0	8.50	.90	226.5	63.2	830

Rotation: Clockwise

Airflow Outlet: Air Out Over Struts

*1: Average Values in Free Air

** Contact NMB for availability

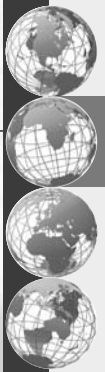

EXTERNAL ROTOR BRUSHLESS DC MOTORS

The NMB range of Blower products has been designed to utilize the benefits of external rotor DC brushless motor. Standard axial fans are offered with both AC and brushless DC motors.

Motor Construction

The motor assembly comprises two major sub-assemblies, rotor and stator. A multi-pole rotor is formed from a ring of permanent magnet material installed within a steel rotor cup. The cup combines the functions of magnetic return path, magnet containment and mechanical interface to the impeller. The relatively high inertia of the external rotor construction is advantageous in reducing acoustic noise and minimizing small speed disturbances. Because the rotor requires no magnetizing current, motor efficiency is higher than an equivalent AC induction motor.

The stator consists of a stack of externally slotted electrical iron laminations, electrically insulated and wound with enamelled copper wire. This wound assembly is mounted onto the base plate, which also supports a printed circuit board containing the drive electronics and rotor position sensing element. This results in a very compact assembly with all the heat-producing components integrated into a single sub-assembly.

Motor Assembly

By virtue of being installed within the impeller, the motor benefits from efficient cooling, maximizing the life of the product while minimizing the overall height of the fan. All rotating parts are assembled using NMB ball bearings and then balanced as a single component to reduce vibration and bearing loads for improved reliability.

Simple motor construction and minimal parts count ensure a high reliability, cost-effective solution. NMB has further evolved this construction method to include totally enclosed motor drive electronics, allowing the product to withstand adverse environmental conditions.

All the traditional benefits of brushless DC motor technology are available, such as long life, high efficiency, high momentary torque, integral speed sensing and speed controllability.

Features Available

The following features are standard on NMB fan using 92mm motors.

- Variable speed control by either voltage or PWM input
- Motor speed (Tacho) output signal
- Locked rotor protection
- Motor overload protection
- Motor slow start
- Wide voltage supply range
- Reverse connection protection

In addition to the standard features the following can be included as required.

- IP54 protection
- Fan fault line(s)
- Closed loop speed control
- Bi-directional communication (typically configured as I²C bus)
- Integral RFI filtering
- Over/Under voltage indication or protection
- Speed indication or protection

NOTE:

The information above represents typical performance of the product, and is subject to change without notice. Product performance may be varied or enhanced to meet individual requirements.



Product	Size (mm)	Airflow (m ³ /H)	Pressure (Pa)
101R057	∅101x57	233	480
133R091	∅133x91	Under Development	
160R054	∅160x54	Under Development	
175R069	∅175x69	735	604
190R071	∅190x71	734	723
220R071	∅220x71	1102	672
225R099	∅225x99	1154	665
250R100	∅250x100	1454	670
280R125	∅280x125	1656	504

Part Numbering System

$\frac{175}{\textcircled{1}}$
 $\frac{R}{\textcircled{2}}$
 $\frac{069}{\textcircled{3}}$
 $\frac{D}{\textcircled{4}}$
 $\frac{07}{\textcircled{5}}$
 $\frac{3X}{\textcircled{6}}$
 $- \frac{AXX}{\textcircled{7}}$

1. Impeller Diameter (mm)
2. Fan Type (R-Radial Blower)
3. Height of Impeller (mm)
4. Electrical Supply (D:DC)
5. Electrical Voltage
 - 04: 12V
 - 05: 24V
 - 06: 36V
 - 07: 48V
 - 08: 54V
 - 09: Other
6. Speed
 - 1<2<3<4<5<6
 - low high
7. Production Specs
 - Defines Production Specification



General Specifications

Motor Protection:

Locker Rotor, Reverse Polarity

Insulation Resistance:

100M Ω or over with a DC500V Megger

Dielectric Withstand Voltage: AC 700V 1s

Allowable Ambient Temperature Range:

-30°C ~ +70°C (Operating)

-40°C ~ +70°C (Storage)

Expected Life

Failure Rate: 10%

40°C 70,000 Hours

Outline

Units: $\frac{\text{inch}}{\text{mm}}$

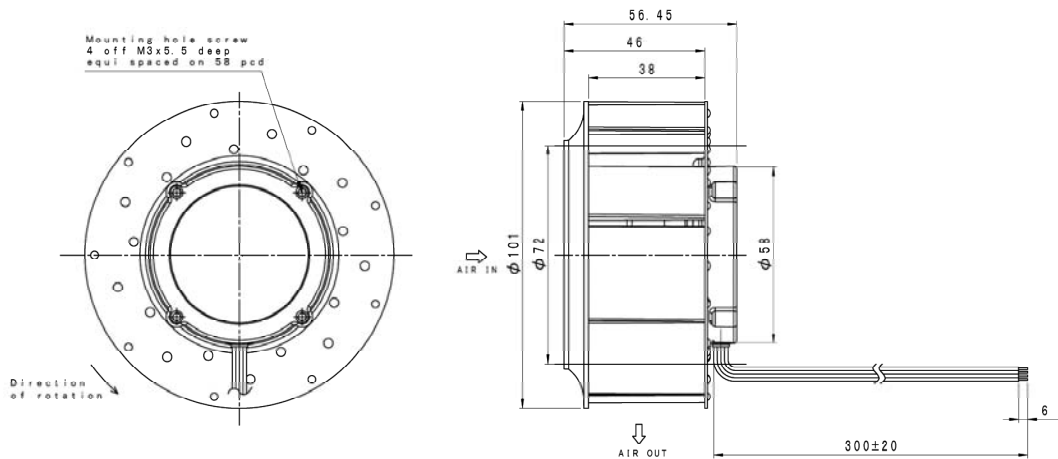

Characteristic Curves

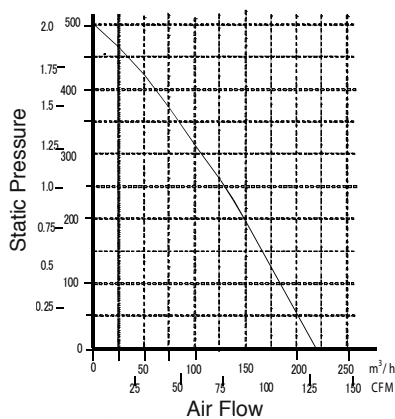

Material

Impeller : Plastic

Bearing : Ball Bearings

Specifications

MODEL	Product No.	Rated Voltage	Operating Voltage	Current	Input Power	Speed	Max. Air Flow		Max. Static Pressure		Noise	Mass
		(V)	(V)	(A) ^{*1}	(W) ^{*1}	(min ⁻¹) ^{*1}	CFM ^{*1}	(m ³ /H)	in H ₂ O	(Pa) ^{*1}	(dB) ^{*1}	(g)
101R057-DO5	AXX	24	16 ~ 28	1.2	288	5670	137.1	233	1.9	480	63.0	-
101R057-DO7	AXX	48	36 ~ 57	0.6	288	5670	137.1	233	1.9	480	63.0	-

*1: Average Values in Free Air



General Specifications

Motor Protection:

Locker Rotor, Reverse Polarity

Insulation Resistance:

100M Ω or over with a DC500V Megger

Dielectric Withstand Voltage: AC 700V 1s

Allowable Ambient Temperature Range:

-30°C ~ +70°C (Operating)

-40°C ~ +70°C (Storage)

Expected Life

Failure Rate: 10%

40°C 70,000 Hours

Outline

Units: $\frac{\text{inch}}{\text{mm}}$

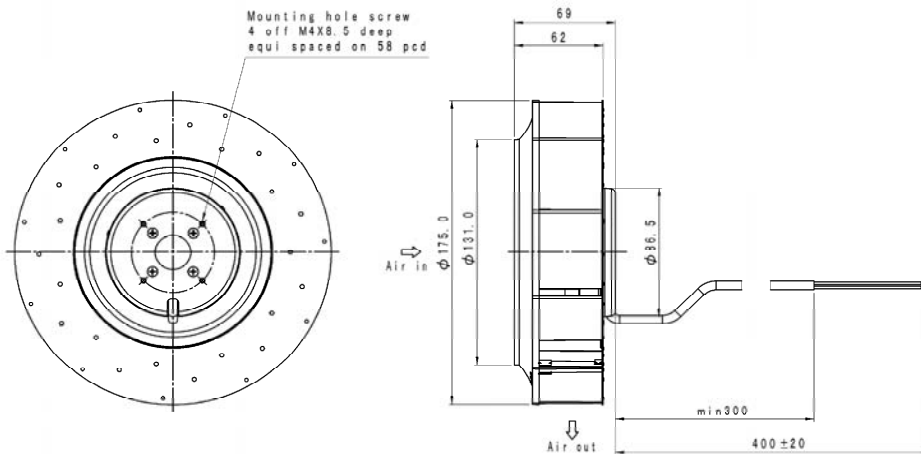

Characteristic Curves

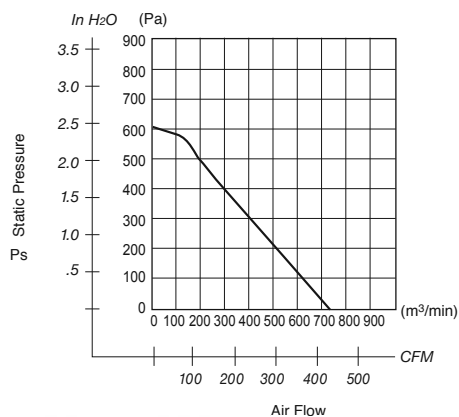

Material

Impeller : Plastic

Bearing : Ball Bearings

Specifications

MODEL	Product No.	Rated Voltage	Operating Voltage	Current	Input Power	Speed	Max. Air Flow		Max. Static Pressure		Noise	Mass
		(V)	(V)	(A) ^{*1}	(W) ^{*1}	(min ⁻¹) ^{*1}	CFM ^{*1}	(m³/H)	in H ₂ O	(Pa) ^{*1}	(dB) ^{*1}	(g)
175R069-DO5	AXX	24	16 ~ 28	4.3	103	4400	432.6	735	2.4	604	73.0	-
175R069-DO7	AXX	48	36 ~ 57	2.0	96	4400	432.6	735	2.4	604	73.0	-

*1: Average Values in Free Air



General Specifications

Motor Protection:

Locker Rotor, Reverse Polarity

Insulation Resistance:

100M Ω or over with a DC500V Megger

Dielectric Withstand Voltage: AC 700V 1s

Allowable Ambient Temperature Range:

-30°C ~ +70°C (Operating)

-40°C ~ +70°C (Storage)

Expected Life

Failure Rate: 10%

40°C 70,000 Hours

Outline

Units: $\frac{\text{inch}}{\text{mm}}$

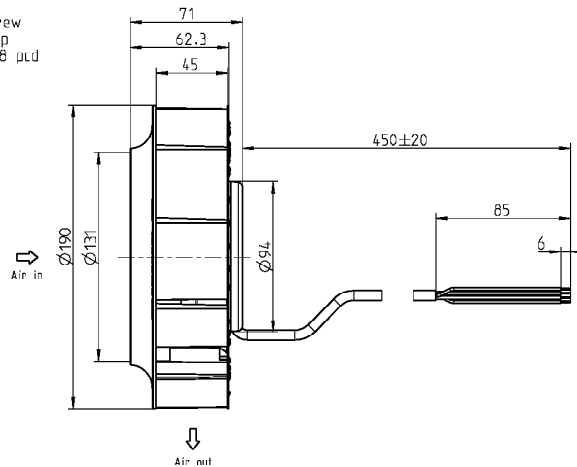
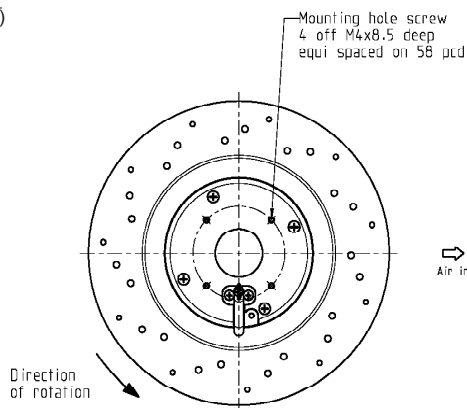

Characteristic Curves

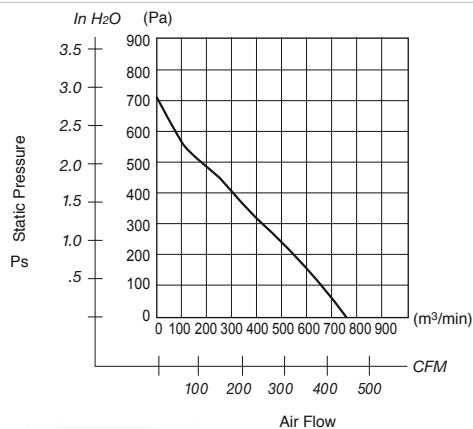

Material

Impeller : Plastic

Bearing : Ball Bearings

Specifications

MODEL	Product No.	Rated Voltage	Operating Voltage	Current	Input Power	Speed	Max. Air Flow		Max. Static Pressure		Noise	Mass
		(V)	(V)	(A) ^{*1}	(W) ^{*1}	(min ⁻¹) ^{*1}	CFM ^{*1}	(m ³ /H)	in H ₂ O	(Pa) ^{*1}	(dB) ^{*1}	(g)
190R071-DO5	AXX	24	16 ~ 28	4.6	110	3450	432.0	734	2.8	723	74.0	-
190R071-DO7	AXX	48	36 ~ 57	2.15	103	3450	432.0	734	2.8	723	73.0	-

*1: Average Values in Free Air



General Specifications

Motor Protection:

Locker Rotor, Reverse Polarity

Insulation Resistance:

100M Ω or over with a DC500V Megger

Dielectric Withstand Voltage: AC 700V 1s

Allowable Ambient Temperature Range:

-30°C ~ +70°C (Operating)

-40°C ~ +70°C (Storage)

Expected Life

Failure Rate: 10%

40°C 70,000 Hours

Outline

Units: $\frac{\text{inch}}{\text{mm}}$

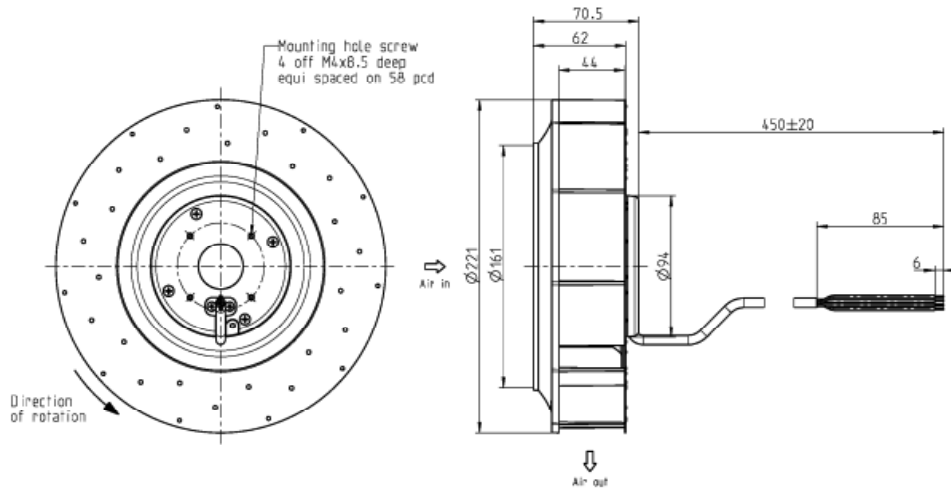

Characteristic Curves

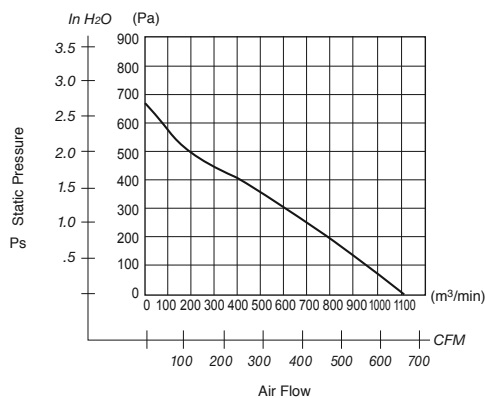

Material

Impeller : Plastic

Bearing : Ball Bearings

Specifications

MODEL	Product No.	Rated Voltage	Operating Voltage	Current	Input Power	Speed	Max. Air Flow		Max. Static Pressure		Noise	Mass
		(V)	(V)	(A) ^{*1}	(W) ^{*1}	(min ⁻¹) ^{*1}	CFM ^{*1}	(m³/H)	in H ₂ O	(Pa) ^{*1}	(dB) ^{*1}	(g)
220R071-DO5	AXX	24	16 ~ 28	4.7	113	3240	648.6	1102	2.6	672	74.0	-
220R071-DO7	AXX	48	36 ~ 57	2.3	110	3120	648.6	1102	2.6	672	73.0	-

*1: Average Values in Free Air



General Specifications

Motor Protection:

Locker Rotor, Reverse Polarity

Insulation Resistance:

100M Ω or over with a DC500V Megger

Dielectric Withstand Voltage: AC 700V 1s

Allowable Ambient Temperature Range:

-30°C ~ +70°C (Operating)

-40°C ~ +70°C (Storage)

Expected Life

Failure Rate: 10%

40°C 70,000 Hours

Outline

Units: $\frac{\text{inch}}{\text{mm}}$

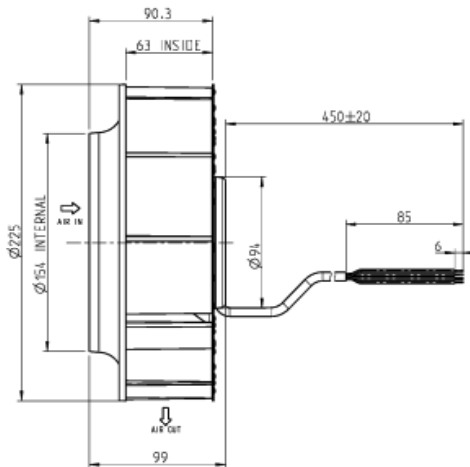
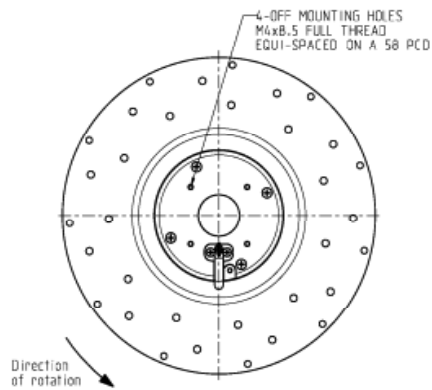

Characteristic Curves

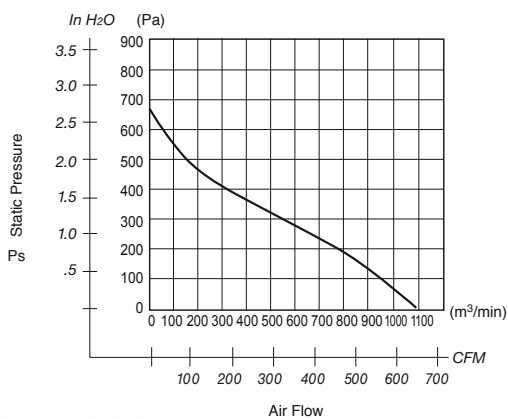

Material

Impeller : Plastic

Bearing : Ball Bearings

Specifications

MODEL	Product No.	Rated Voltage	Operating Voltage	Current	Input Power	Speed	Max. Air Flow		Max. Static Pressure		Noise	Mass
		(V)	(V)	(A) ^{*1}	(W) ^{*1}	(min ⁻¹) ^{*1}	CFM ^{*1}	(m ³ /H)	in H ₂ O	(Pa) ^{*1}	(dB) ^{*1}	(g)
225R099-DO5	AXX	24	16 ~ 28	4.3	104	2750	679.2	1154	2.6	665	68.5	-
225R099-DO7	AXX	48	36 ~ 57	1.8	89	2750	679.2	1154	2.6	665	68.5	-

*1: Average Values in Free Air



General Specifications

Motor Protection:

Locker Rotor, Reverse Polarity

Insulation Resistance:

100M Ω or over with a DC500V Megger

Dielectric Withstand Voltage: AC 700V 1s

Allowable Ambient Temperature Range:

-30°C ~ +70°C (Operating)

-40°C ~ +70°C (Storage)

Expected Life

Failure Rate: 10%

40°C 70,000 Hours

Outline

Units: $\frac{\text{inch}}{\text{mm}}$

Mounting hole screw
4 off M4x8.5 deep
equi spaced on 58 pcd

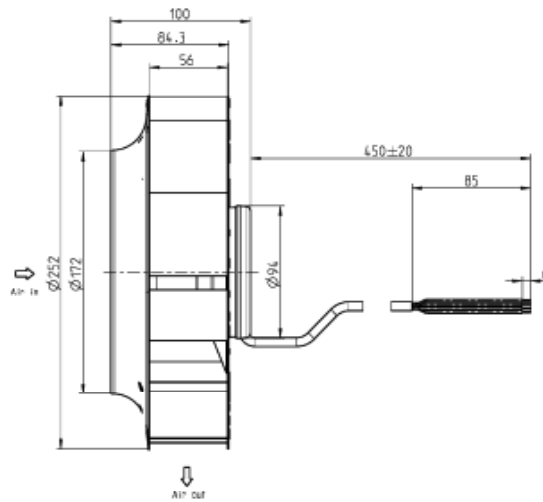
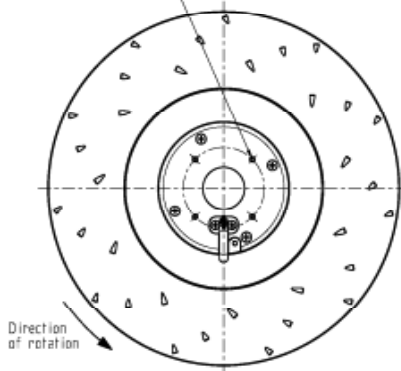

Characteristic Curves

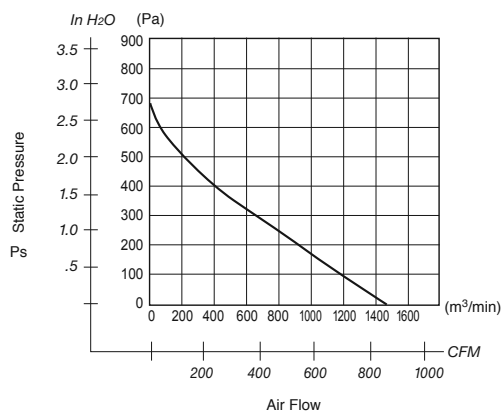

Material

Impeller : Metal

Bearing : Ball Bearings

Specifications

MODEL	Product No.	Rated Voltage	Operating Voltage	Current	Input Power	Speed	Max. Air Flow		Max. Static Pressure		Noise	Mass
		(V)	(V)	(A) ^{*1}	(W) ^{*1}	(min ⁻¹) ^{*1}	CFM ^{*1}	(m³/H)	in H ₂ O	(Pa) ^{*1}	(dB) ^{*1}	(g)
250R100-DO5	AXX	24	16 ~ 28	5.0	120	2500	855.7	1454	2.6	670	71.0	-
250R100-DO7	AXX	48	36 ~ 57	2.35	113	2500	855.7	1454	2.6	670	72.0	-

*1: Average Values in Free Air



General Specifications

Motor Protection:

Locker Rotor, Reverse Polarity

Insulation Resistance:

100M Ω or over with a DC500V Megger

Dielectric Withstand Voltage: AC 700V 1s

Allowable Ambient Temperature Range:

-30°C ~ +70°C (Operating)

-40°C ~ +70°C (Storage)

Expected Life

Failure Rate: 10%

40°C 70,000 Hours

Outline

Units: $\frac{\text{inch}}{\text{mm}}$

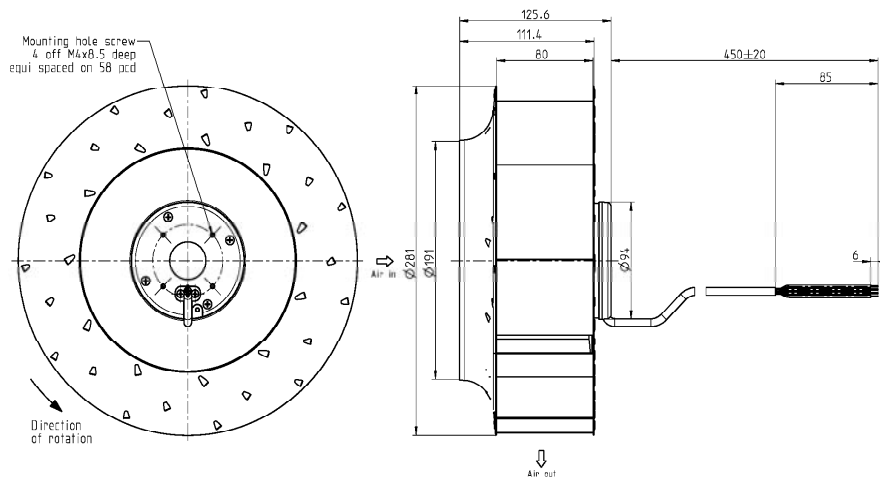

Characteristic Curves

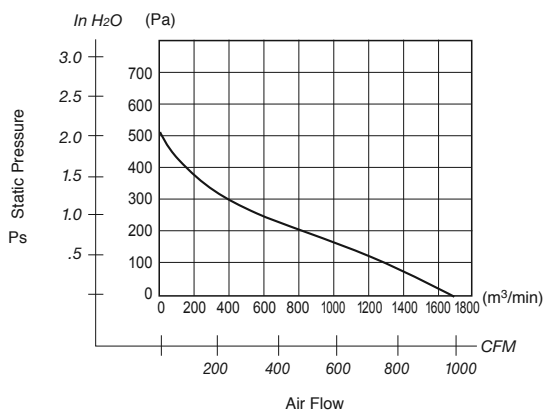

Material

Impeller : Metal

Bearing : Ball Bearings

Specifications

MODEL	Product No.	Rated Voltage	Operating Voltage	Current	Input Power	Speed	Max. Air Flow		Max. Static Pressure		Noise	Mass
		(V)	(V)	(A) ^{*1}	(W) ^{*1}	(min ⁻¹) ^{*1}	CFM ^{*1}	(m³/H)	in H ₂ O	(Pa) ^{*1}	(dB) ^{*1}	(g)
280R125-DO5	AXX	24	16 ~ 28	4.5	108	1815	974.6	1656	2.02	504	68.5	-
280R125-DO7	AXX	48	36 ~ 57	1.9	91	1815	974.6	1656	2.02	504	68.5	-

*1: Average Values in Free Air



Common Specifications

- Vibration Test:..... Conforms to JIS C 60068-2-6, Amplitude: 1.5mm, Frequency 10 to 55 Hz, 1 hour. In each of the X, Y and Z directions.
- Shock Test:..... Conforms to JIS C 60068-2-27, Acceleration 981 m/s²*, Application time 6ms, Once each in the X, Y and Z directions. Note: 1004KL, 1204KL, 1404KL, 1604KL, 1606KL, 1608KL, 2004KL, 2106KL, 2404KL, 2406KL, BM4515, BM5115, BM5125 and BM6015 Series The conditions of shock test on the listed models are as follows, Acceleration rate: 500 m/s², Application time: 11ms, Once each in the X, Y and Z directions.
- Locked Rotor Protection : .. The motor is protected from burnout in the locked rotor condition for 72 hours, at the rated voltage.
- Polarity Protection : The fans are Reverse Polarity protected at the rated voltage.
- Insulation Class : E class (UL: Class A)
- Auto Restart:..... Most fan models provide current shut-down/auto restart function under locked rotor conditions.

Notes: Additional performance requirements can be determined between manufacturer and customer, based on customer's request. Ball bearing fans and blowers may be installed in a horizontal, vertical or angled position

BM Series Part Numbering System

BM 51 15 - 04 W - B 3 0 - L 00
 ① ② ③ ④ ⑤ ⑥ ⑦ ⑧ ⑨ ⑩

- | | | | |
|--|--|--|---|
| 1. Series
BM Series | 1: 5V 5: 24V
2: 6V 6: 36V | 8. Special Control Function
0: Standard Type
9: Sensor Type
8: 2-Speed Type
7: Temperature Detecting Variable Speed Type/PWM Control Type
6: Temperature Detecting Variable Speed Type/Sensor Type
5: 2-Speed Type/Sensor Type | 10. Individual Specifications
Standard Type
00: Standard
01~99: Custom Sensor Type
00: Locked Rotor Alarm Signal (Standard Type)
01~49: Locked Rotor Alarm Signal (Custom Type)
50: Tachometer Signal (Standard Type)
51~99: Tachometer Signal (Custom Type) |
| 2. Size
45: 45mm
51: 51mm
60: 60mm | 3: 9V 7: 48V
4: 12V 9: Other | 9. Classification
L-Standard Model/Rib Type
T-Value Model/Rib Type | |
| 3. Thickness
15: 15mm
25: 25mm | 5. Termination
Lead Wire | | |
| 4. Input Voltage
O: Standard Current
C: Special Current
D~Z: Special Current
(A.B.O. are not used) | 6. Bearing
B: Ball Bearing
S: Sleeve Bearing | | |
| | 7. Speed
1<2<3<4<5
low high | | |

BG Series Part Numbering System

BG 07 03 - B 04 - 4 - 000 - 00
 ① ② ③ ④ ⑤ ⑥ ⑦ ⑧

- | | | | |
|---|--|--|--|
| 1. Series
BG Series | 4. Bearing
B: Ball Bearing
S: Sleeve Bearing | 6. Speed
1<2<3<4<5
low high | B: Thermistor Mounting Position
O: No Thermistor
T: Thermistor On PCB |
| 2. Size
07: 75mm
08: 80mm
09: 95mm
10: 100mm
12: 120mm | 5. Input Voltage
O: Standard Current
C: Special Current
D~Z: Special Current
(A.B.O. are not used) | 7. Special Control Function
0 0 0
A B C | C: Output Signal
O: No Signal
L: Locked Rotor Alarm Signal
S: Tachometer Signal |
| 3. Thickness
01: 18mm
02: 25mm
03: 30~33mm | | A: Special Control Function
O: Fix Speed Type
2: 2-Speed Type
V: Temperature Detecting Variable Speed Type
P: PWM Control Type | 8. Product Number
00 : Standard
01~ : Customized Standard
T0 : Standard Value
T1~ : Customized Value |

FAL Series Part Numbering System

FAL 6 F - 12 L - H - S - A
 ① ② ③ ④ ⑤ ⑥ ⑦ ⑧

- | | | | |
|---|--|---|--|
| 1. Motor Type
FAL: DC Blowers | 3. Model Change | 5. Direction of Rotation
L: CCW
R: CW
Up side from rotor | 7. Option
S: Locked Sensor
□: Without Sensor |
| 2. Core Thickness
03: 2.7~3.1mm
05: 5.8~6.3mm
06: 5.5~6.4mm
14: 13.5~14.4mm | 4. Rated Voltage
05: 5V
12: 12V
24: 24V | 6. Speed
H: High Speed
L: Low Speed | 8. Design Code |

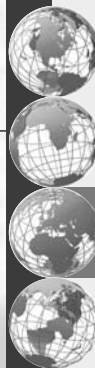

General Specifications

Allowable Ambient Temperature Range:

- B50 Class: -10°C ~ +60°C (Operating)
- B30 ~ B40 Class: -10°C ~ +70°C (Operating)
- All Class: -40°C ~ +70°C (Storage)

Expected Life

- Failure Rate: 10%
- 25°C 50,000 Hours (L00)

Outline

Units: $\frac{\text{inch}}{\text{mm}}$

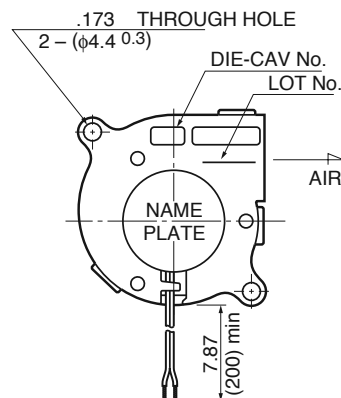
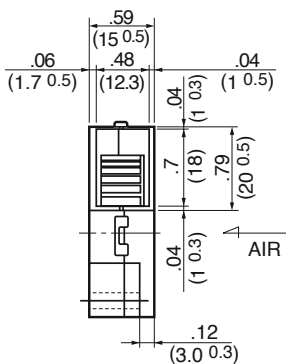
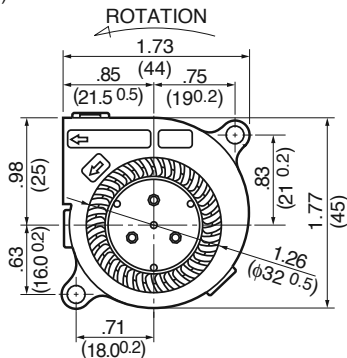

Characteristic Curves

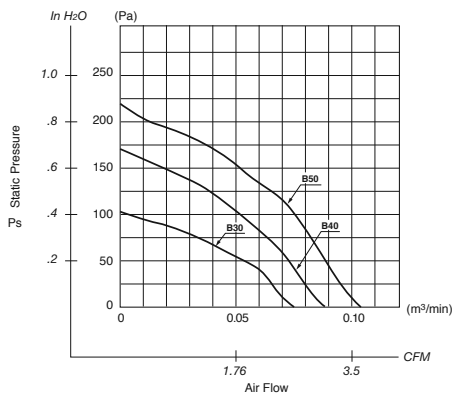

Material

- Casing : Plastic (Black) 94V-0
- Impeller : Plastic (Black) 94V-0
- Bearing : Ball Bearing
- Lead Wire : UL1061, AWG26, +Red, -Black

Specifications

MODEL	Product No.	Rated Voltage	Operating Voltage	Current	Input Power	Speed	Max. Air Flow		Max. Static Pressure		Noise	Mass
		(V)	(V)	(A) ^{*1}	(W) ^{*1}	(min ⁻¹) ^{*1}	CFM ^{*1}	(m ³ /min) ^{*1}	in H ₂ O	(Pa) ^{*1}	(dB) ^{*1}	(g)
BM4515-04W-B30-	L00	12	10.2 ~ 13.8	0.09	1.08	5500	2.6	0.08	.40	100	35.0	25
BM4515-04W-B40-	L00	12	10.2 ~ 13.8	0.14	1.68	6500	3.0	0.09	.64	160	39.0	25
BM4515-04W-B50-	L00	12	10.2 ~ 13.8	0.19	2.28	7500	3.5	0.10	.80	200	43.0	25

Rotation: Clockwise

Airflow Outlet: Air Out Over Struts

*1: Average Values in Free Air

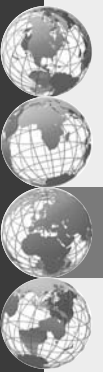

General Specifications

Allowable Ambient Temperature Range:

-10°C ~ +60°C (65%RH) (Operating)
 -40°C ~ +75°C (65%RH) (Storage)
 (non-condensing environment)

Expected Life

Failure Rate: 10%
 20,000 Hours (25°C, 65%RH)

Outline

Units: $\frac{\text{inch}}{\text{mm}}$

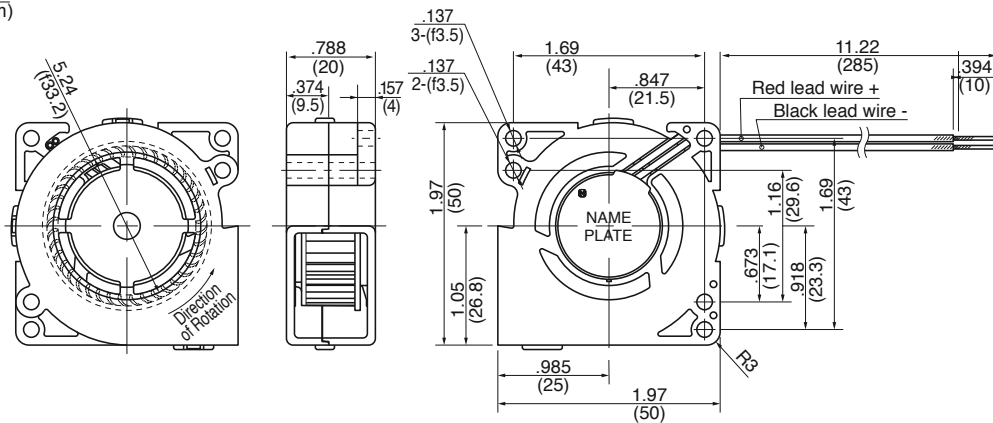

Characteristic Curves

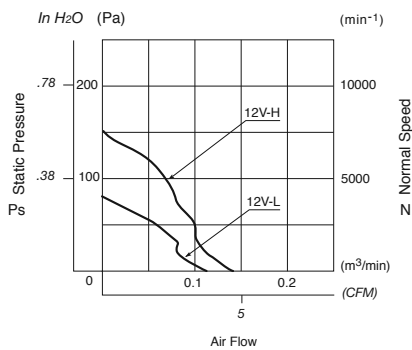

Material

Bearing : Ball Bearing

Specifications

MODEL	Rated Voltage	Operating Voltage	Current	Input Power	Rated Speed	Max. Air Flow		Max. Static Pressure		Noise	Mass
	(V)	(V)	(A) ^{*1}	(W) ^{*1}	(min ⁻¹) ^{*1}	CFM ^{*1}	(m ³ /min) ^{*1}	in H ₂ O	(Pa) ^{*1}	(dB) ^{*1}	(g)
FAL3F 05LL	5	4.5 ~ 6.0	205	1.64	4400	3.95	0.11	.31	79.4	28.5	40
FAL3F 05LH	5	4.5 ~ 6.0	380	1.90	5400	4.94	0.14	.60	151.0	36.0	40
FAL3F 12LL	12	7.0 ~ 13.8	111	1.33	4400	3.95	0.11	.31	79.4	28.5	40
FAL3F 12LH	12	7.0 ~ 13.8	185	2.22	5200	4.87	0.13	.60	151.0	35.0	40
FAL3F 24LH	24	14.0 ~ 27.6	105	2.52	5200	4.87	0.13	.60	151.0	35.0	40

Rotation: Clockwise

Airflow Outlet: Air Out Over Struts

*1: Average Values in Free Air

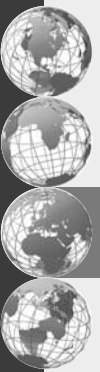

General Specifications

Allowable Ambient Temperature Range:

- 10°C ~ +70°C (Operating)
- 40°C ~ +70°C (Storage)
- (non-condensing environment)

Expected Life

- Failure Rate: 10%
- 25°C 50,000 Hours (L00)

Outline

Units: $\frac{\text{inch}}{\text{mm}}$

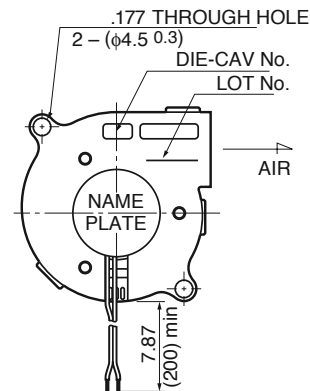
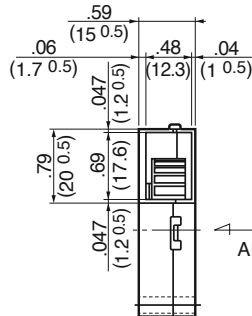
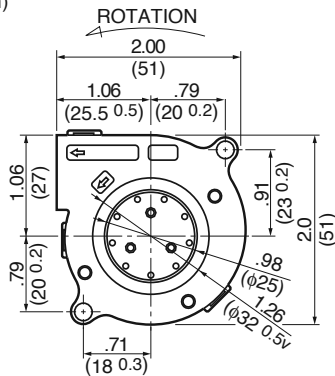

Characteristic Curves

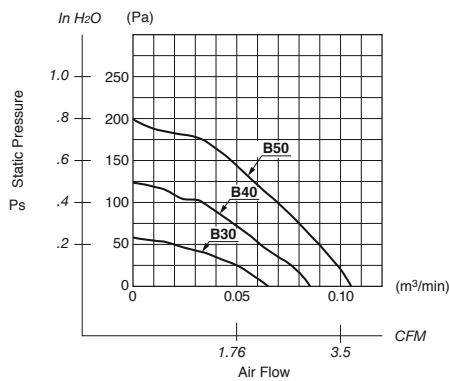

Material

- Casing : Plastic (Black) 94V-0
- Impeller : Plastic (Black) 94V-0
- Bearing : Ball Bearing
- Lead Wire : UL1061, AWG26, +Red, -Black

Specifications

MODEL	Product No.	Rated Voltage	Operating Voltage	Current	Input Power	Speed	Max. Air Flow		Max. Static Pressure		Noise	Mass
		(V)	(V)	(A) ^{*1}	(W) ^{*1}	(min ⁻¹) ^{*1}	CFM ^{*1}	(m ³ /min) ^{*1}	in H ₂ O	(Pa) ^{*1}	(dB) ^{*1}	(g)
BM5115-04W-B30-	X00	12	10.2 ~ 13.8	0.06	0.72	3500	2.1	0.06	.24	60	26.0	25
BM5115-04W-B40-	X00	12	10.2 ~ 13.8	0.12	1.44	4500	2.8	0.08	.48	120	35.0	25
BM5115-04W-B50-	X00	12	10.2 ~ 13.8	0.18	2.16	5500	3.5	0.10	.80	200	42.0	25

Rotation: Clockwise

Airflow Outlet: Air Out Over Struts

*1: Average Values in Free Air

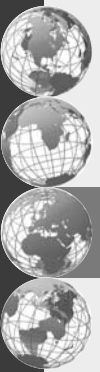

General Specifications

Allowable Ambient Temperature Range:

B50 Class: -10°C ~ +60°C (Operating)
 B30 ~ B40 Class: -10°C ~ +70°C (Operating)
 All Class: -40°C ~ +70°C (Storage)
 (non-condensing environment)

Expected Life

Failure Rate: 10%
 25°C 50,000 Hours (L00)

Outline

Units: $\frac{\text{inch}}{\text{mm}}$

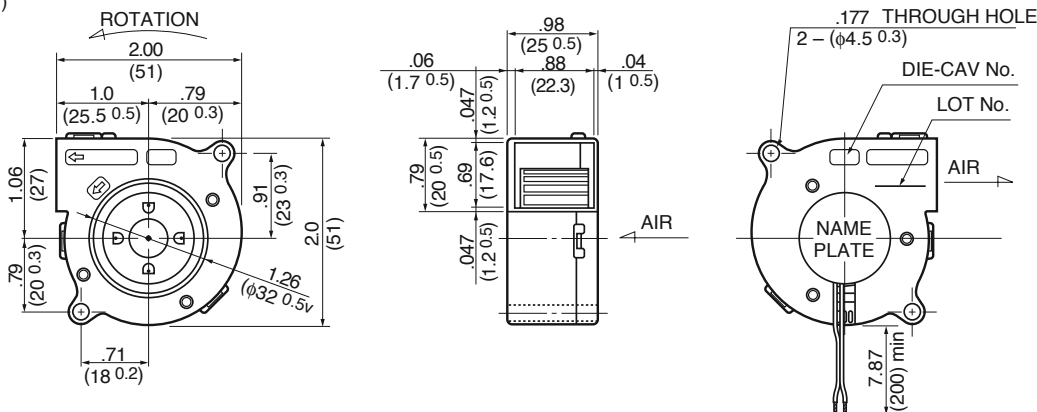

Characteristic Curves

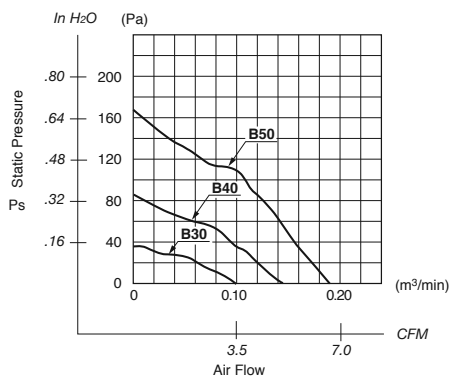

Material

Casing : Plastic (Black) 94V-0
 Impeller : Plastic (Black) 94V-0
 Bearing : Ball Bearing
 Lead Wire : UL1061, AWG26, +Red, -Black

Specifications

MODEL	Product No.	Rated Voltage	Operating Voltage	Current	Input Power	Speed	Max. Air Flow		Max. Static Pressure		Noise	Mass
		(V)	(V)	(A) ^{*1}	(W) ^{*1}	(min ⁻¹) ^{*1}	CFM ^{*1}	(m³/min) ^{*1}	in H ₂ O	(Pa) ^{*1}	(dB) ^{*1}	(g)
BM5125-04W-B30-	L00	12	10.2 ~ 13.8	0.06	0.72	2500	3.5	0.10	.14	35	27.0	35
BM5125-04W-B40-	L00	12	10.2 ~ 13.8	0.13	1.56	3500	5.3	0.15	.34	85	34.0	35
BM5125-04W-B50-	L00	12	10.2 ~ 13.8	0.24	2.88	4500	6.7	0.19	.64	160	41.0	35

Rotation: Clockwise

Airflow Outlet: Air Out Over Struts

*1: Average Values in Free Air

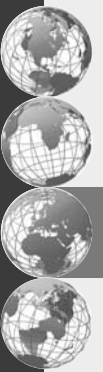

General Specifications

Allowable Ambient Temperature Range:

- 10°C ~ +70°C (Operating)
- 40°C ~ +70°C (Storage)
- (non-condensing environment)

Expected Life

- Failure Rate: 10%
- 25°C 50,000 Hours (L00)

Outline

Units: $\frac{\text{inch}}{\text{mm}}$

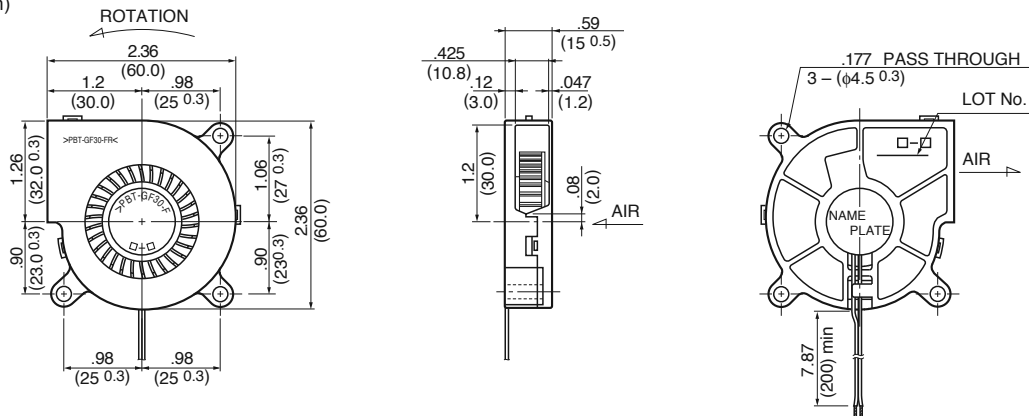

Characteristic Curves

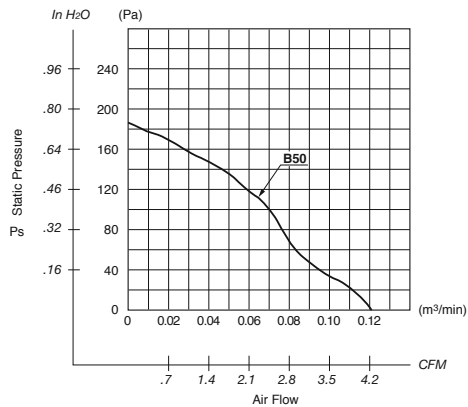

Material

- Casing : Plastic (Black) 94V-0
- Impeller : Plastic (Black) 94V-0
- Bearing : Ball Bearing
- Lead Wire : UL1007, AWG26, +Red, -Black

Specifications

MODEL	Product No.	Rated Voltage	Operating Voltage	Current	Input Power	Speed	Max. Air Flow		Max. Static Pressure		Noise	Mass
		(V)	(V)	(A) ^{*1}	(W) ^{*1}	(min ⁻¹) ^{*1}	CFM ^{*1}	(m ³ /min) ^{*1}	in H ₂ O	(Pa) ^{*1}	(dB) ^{*1}	(g)
BM6015-04W-B50-	L00	12	9 ~ 12.6	0.22	2.64	5600	4.2	0.12	.68	168.9	42.0	30

Rotation: Clockwise

Airflow Outlet: Air Out Over Struts

*1: Average Values in Free Air

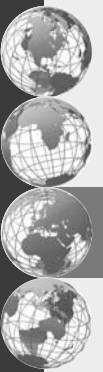

General Specifications

Allowable Ambient Temperature Range:

-10°C ~ +60°C (Operating)
 -40°C ~ +60°C (Storage)
 (non-condensing environment)

Expected Life

Failure Rate: 10%
 25°C 50,000 Hours (L00)

Outline

Units: $\frac{\text{inch}}{\text{mm}}$

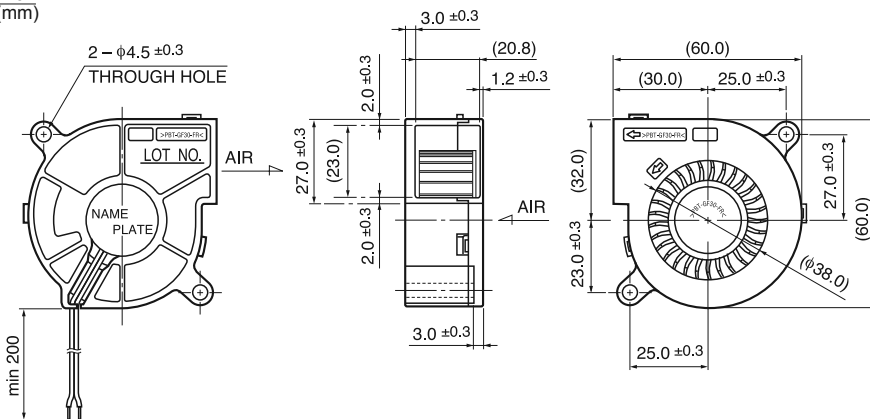

Characteristic Curves

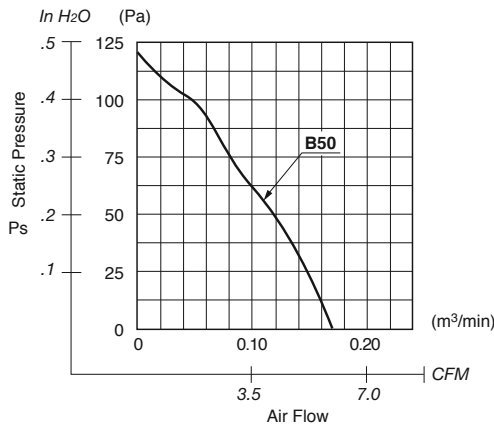

Material

Casing : Plastic (Black) 94V-0
 Impeller : Plastic (Black) 94V-0
 Bearing : Ball Bearing
 Lead Wire : UL1061, AWG26, +Red, -Black

Specifications

MODEL	Product No.	Rated Voltage	Operating Voltage	Current	Input Power	Speed	Max. Air Flow		Max. Static Pressure		Noise	Mass
		(V)	(V)	(A) ^{*1}	(W) ^{*1}	(min ⁻¹) ^{*1}	CFM ^{*1}	(m ³ /min) ^{*1}	in H ₂ O	(Pa) ^{*1}	(dB) ^{*1}	(g)
** BM6025-04W-B50-	T00	12	10.0 ~ 13.0	0.32	3.84	3500	6.0	0.17	0.48	121.9	31	35

Rotation: Clockwise

Airflow Outlet: Air Out Over Struts

*1: Average Values in Free Air

** Contact NMB for availability

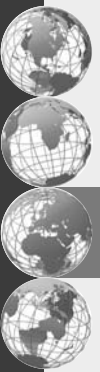

General Specifications

Allowable Ambient Temperature Range:

-10°C ~ +70°C (Operating)
 -40°C ~ +70°C (Storage)
 (non-condensing environment)

Expected Life

Failure Rate: 10%
 25°C 70,000 Hours (00)

Outline

Units: $\frac{\text{inch}}{\text{mm}}$

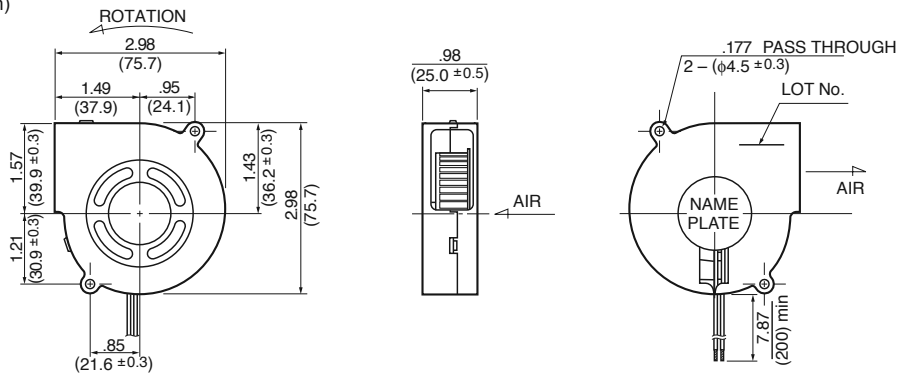

Characteristic Curves

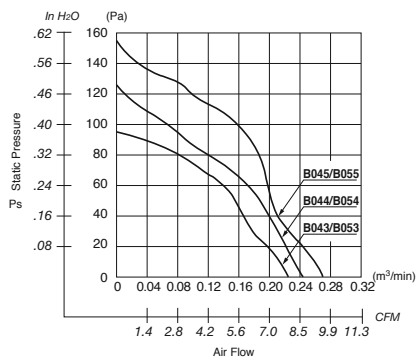

Material

Casing : Plastic (Black) 94V-0
 Impeller : Plastic (Black) 94V-0
 Bearing : Ball Bearing
 Lead Wire : UL1007, AWG26, +Red, -Black

Specifications

MODEL	Product No.	Rated Voltage	Operating Voltage	Current	Input Power	Speed	Max. Air Flow		Max. Static Pressure		Noise	Mass
		(V)	(V)	(A) ^{*1}	(W) ^{*1}	(min ⁻¹) ^{*1}	CFM ^{*1}	(m ³ /min) ^{*1}	in H ₂ O	(Pa) ^{*1}	(dB) ^{*1}	(g)
BG0702- B043 -000-	X0	12	6 ~ 13.8	0.16	1.92	3000	7.76	0.22	.37	94	39.0	90
** BG0702- B044 -000-	X0	12	6 ~ 13.8	0.19	2.28	3300	8.47	0.24	.50	124	41.0	90
BG0702- B045 -000-	X0	12	6 ~ 13.8	0.25	3.00	3600	9.50	0.27	.61	153	43.0	90
** BG0702- B053 -000-	X0	24	10 ~ 27.6	0.10	2.40	3000	7.76	0.22	.37	94	39.0	90
** BG0702- B054 -000-	X0	24	10 ~ 27.6	0.11	2.64	3300	8.47	0.24	.50	124	41.0	90
BG0702- B055 -000-	X0	24	10 ~ 27.6	0.14	3.36	3600	9.50	0.27	.61	153	43.0	90

Rotation: Clockwise

Airflow Outlet: Air Out Over Struts

*1: Average Values in Free Air

** Contact NMB for availability

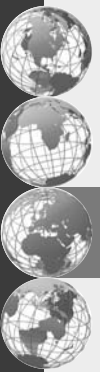

General Specifications

Allowable Ambient Temperature Range:

-10°C ~ +70°C (Operating)
 -40°C ~ +70°C (Storage)
 (non-condensing environment)

Expected Life

Failure Rate: 10%
 25°C 70,000 Hours (00)

Outline

Units: $\frac{\text{inch}}{(\text{mm})}$

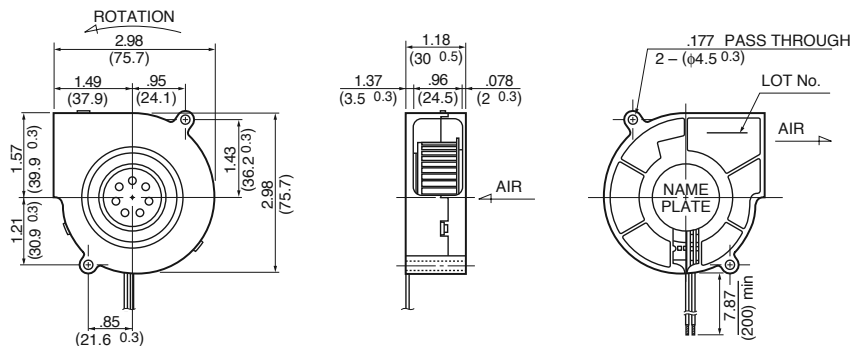

Characteristic Curves

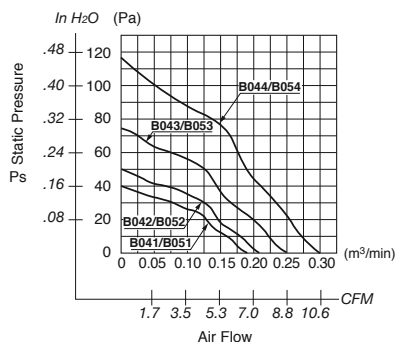

Material

Casing : Plastic (Black) 94V-0
 Impeller : Plastic (Black) 94V-0
 Bearing : Ball Bearing
 Lead Wire : UL1007, AWG26, +Red, -Black

Specifications

MODEL	Product No.	Rated Voltage	Operating Voltage	Current	Input Power	Speed	Max. Air Flow		Max. Static Pressure		Noise	Mass
		(V)	(V)	(A) ^{*1}	(W) ^{*1}	(min ⁻¹) ^{*1}	CFM ^{*1}	(m ³ /min) ^{*1}	in H ₂ O	(Pa) ^{*1}	(dB) ^{*1}	(g)
BG0703-B041-000-	X0	12	6 ~ 13.8	0.10	1.20	2000	6.7	0.19	.16	40	28.0	90
BG0703-B042-000-	X0	12	6 ~ 13.8	0.12	1.44	2200	7.4	0.21	.20	50	29.5	90
BG0703-B043-000-	X0	12	6 ~ 13.8	0.18	2.16	2550	8.8	0.25	.30	75	34.5	90
BG0703-B044-000-	X0	12	6 ~ 13.0	0.29	3.48	3000	10.6	0.30	.44	110	38.5	90
BG0703-B051-000-	X0	24	10 ~ 27.6	0.06	1.44	2000	6.7	0.19	.16	40	28.0	90
BG0703-B052-000-	X0	24	10 ~ 27.6	0.07	1.68	2200	7.4	0.21	.20	50	29.5	90
BG0703-B053-000-	X0	24	10 ~ 27.6	0.09	2.16	2550	8.8	0.25	.30	75	34.5	90
BG0703-B054-000-	X0	24	10 ~ 26.0	0.15	3.60	3000	10.6	0.30	.44	110	38.5	90

Rotation: Clockwise

Airflow Outlet: Air Out Over Struts

*1: Average Values in Free Air

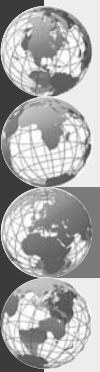

General Specifications

Allowable Ambient Temperature Range:

- 10°C ~ +60°C (65%RH) (Operating)
- 40°C ~ +75°C (65%RH) (Storage)
- (non-condensing environment)

Expected Life

- Failure Rate: 10%
- 40,000 Hours (25°C, 65%RH)

Outline

Units: $\frac{\text{inch}}{\text{mm}}$

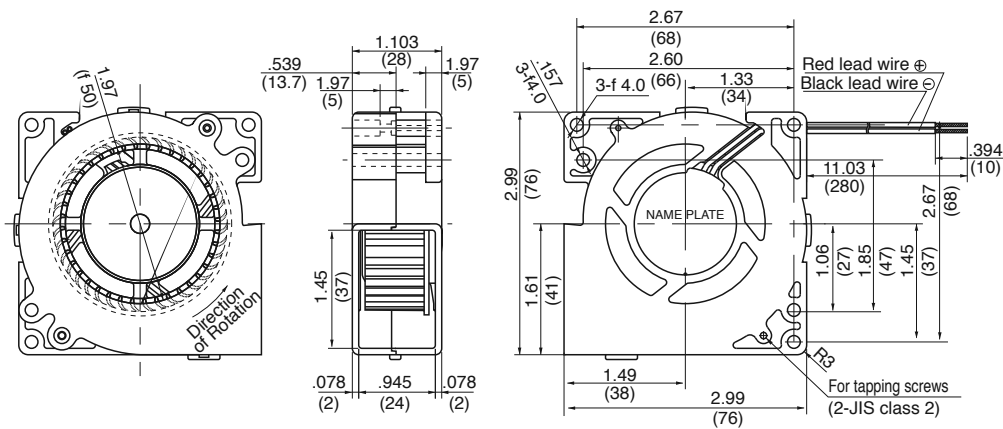

Characteristic Curves

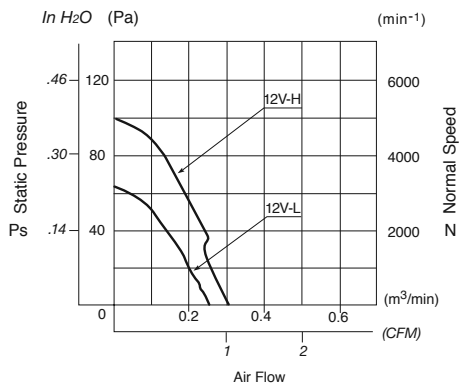

Material

Bearing : Hydro Wave Bearing

Specifications

MODEL	Rated Voltage	Operating Voltage	Current	Input Power	Rated Speed	Max. Air Flow		Max. Static Pressure		Noise	Mass
	(V)	(V)	(A) ^{*1}	(W) ^{*1}	(min ⁻¹) ^{*1}	CFM ^{*1}	(m ³ /min) ^{*1}	in H ₂ O	(Pa) ^{*1}	(dB) ^{*1}	(g)
FAL5F 12LL	12	7.0 ~ 13.8	140	1.68	2400	8.83	0.25	.24	60.8	30.0	100
FAL5F 12LH	12	7.0 ~ 13.8	200	2.40	2900	10.6	0.30	.39	98.0	36.0	100
FAL5F 24LL	24	14.0 ~ 27.6	70	1.68	2400	8.83	0.25	.24	60.8	30.0	100
FAL5F 24LH	24	14.0 ~ 27.6	100	2.40	2900	10.6	0.30	.38	95.1	36.0	100

Rotation: Clockwise

Airflow Outlet: Air Out Over Struts

*1: Average Values in Free Air

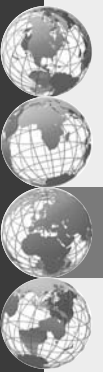

General Specifications

Allowable Ambient Temperature Range:

-10°C ~ +50°C (Operating)
 -40°C ~ +50°C (Storage)
 (non-condensing environment)

Expected Life

Failure Rate: 10%
 25°C 50,000 Hours (000)

Outline

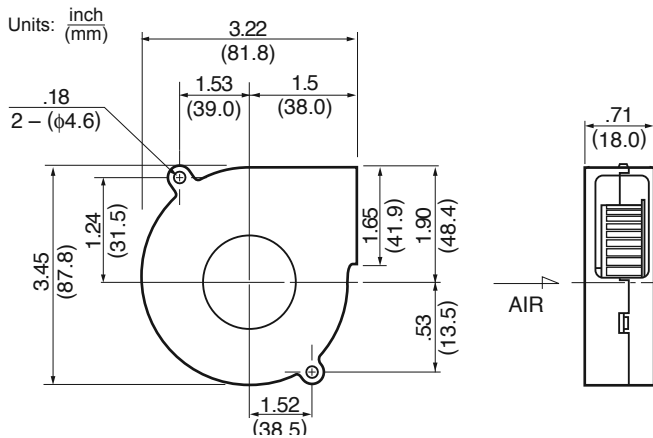

Characteristic Curves

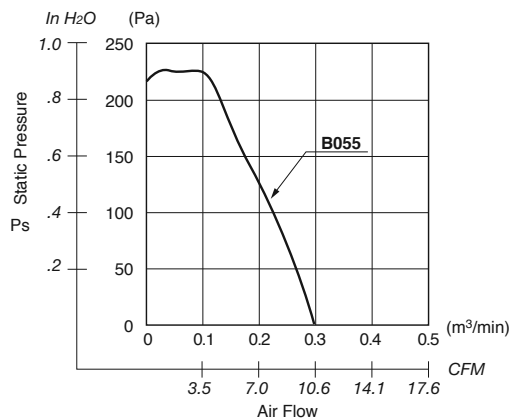

Material

Casing : Plastic (Black) 94V-0
 Impeller : Plastic (Black) 94V-0
 Bearing : Ball Bearing
 Lead Wire : UL1007, AWG26, +Red, -Black

Specifications

MODEL	Product No.	Rated Voltage	Operating Voltage	Current	Input Power	Speed	Max. Air Flow		Max. Static Pressure		Noise	Mass
		(V)	(V)	(A) ^{*1}	(W) ^{*1}	(min ⁻¹) ^{*1}	CFM ^{*1}	(m ³ /min) ^{*1}	in H ₂ O	(Pa) ^{*1}	(dB) ^{*1}	(g)
BG0801-B055-000-	00	24	21.6 ~ 26.4	0.29	3.48	3400	10.2	0.29	.87	219	45	-

Rotation: Counterclockwise

Airflow Outlet: Air Out Over Struts

*1: Average Values in Free Air

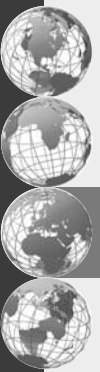

General Specifications

Allowable Ambient Temperature Range:

-10°C ~ +60°C (Operating)
 -40°C ~ +70°C (Storage)
 (non-condensing environment)

Expected Life

Failure Rate: 10%
 25°C 100,000 Hours (00)

Outline

Units: $\frac{\text{inch}}{\text{mm}}$

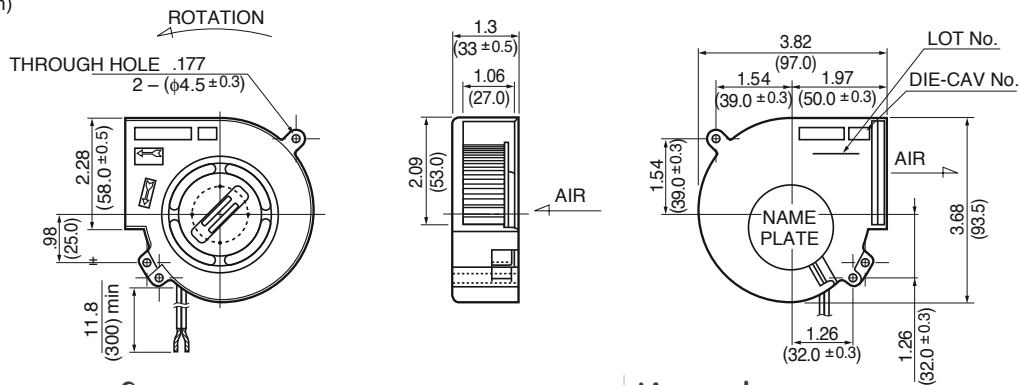

Characteristic Curves

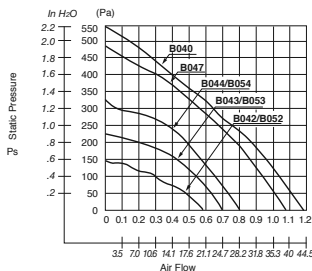

Material

Casing : Plastic (Black) 94V-0
 Impeller : Plastic (Black) 94V-0
 Bearing : Ball Bearing
 Lead Wire : UL1007, AWG26, +Red, -Black

Specifications

MODEL	Product No.	Rated Voltage	Operating Voltage	Current	Input Power	Speed	Max. Air Flow		Max. Static Pressure		Noise	Mass
		(V)	(V)	(A) ^{*1}	(W) ^{*1}	(min ⁻¹) ^{*1}	CFM ^{*1}	(m ³ /min) ^{*1}	in H ₂ O	(Pa) ^{*1}	(dB) ^{*1}	(g)
BG0903-B042-000-	00	12	8 ~ 13.8	0.40	4.80	2700	20.5	0.58	.61	152	47.5	210
BG0903-B043-000-	00	12	8 ~ 13.8	0.64	7.68	3200	24.7	0.70	.90	225	51.5	210
BG0903-B044-000-	00	12	8 ~ 12.6	1.03	12.40	3700	28.6	0.81	1.4	342	54.5	210
BG0903-B052-000-	00	24	10 ~ 27.6	0.21	5.04	2700	20.5	0.58	.61	152	47.5	210
BG0903-B053-000-	00	24	10 ~ 27.6	0.33	7.92	3200	24.7	0.70	.90	225	51.5	210
BG0903-B054-000-	00	24	10 ~ 25.0	0.49	11.80	3700	28.6	0.81	1.4	342	54.5	210
HIGH SPEED												
** BG0903-B040-000-	00	12	10.8 ~ 13.6	2.4	28.90	5700	42.0	1.19	2.2	549	65	210
** BG0903-B047-000-	00	12	10.8 ~ 12.6	1.6	19.20	5200	38.1	1.08	1.9	482	-	210

Rotation: Clockwise

Airflow Outlet: Air Out Over Struts

*1: Average Values in Free Air

** Contact NMB for availability

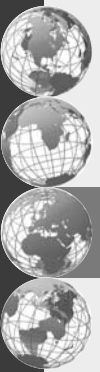

General Specifications

Allowable Ambient Temperature Range:

- 10°C ~ +60°C (Operating)
- 40°C ~ +60°C (Storage)
- (non-condensing environment)

Expected Life

- Failure Rate: 10%
- 25°C 100,000 Hours (00)

Outline

Units: $\frac{\text{inch}}{\text{mm}}$

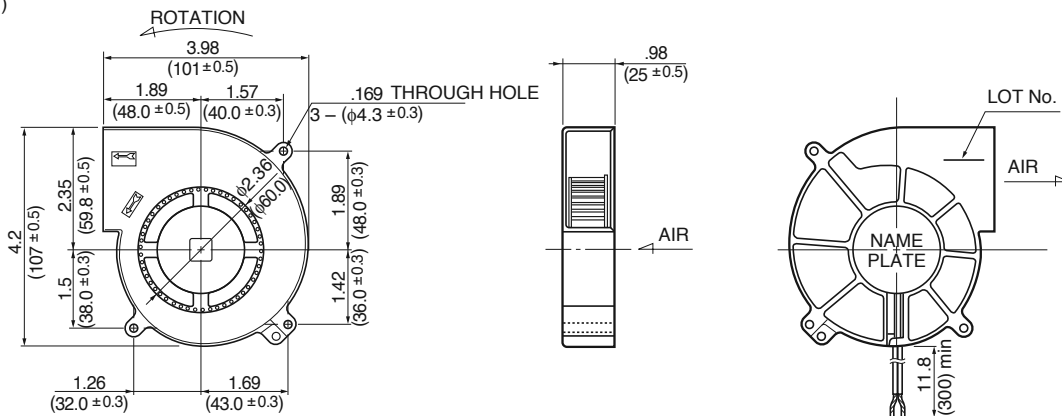

Characteristic Curves

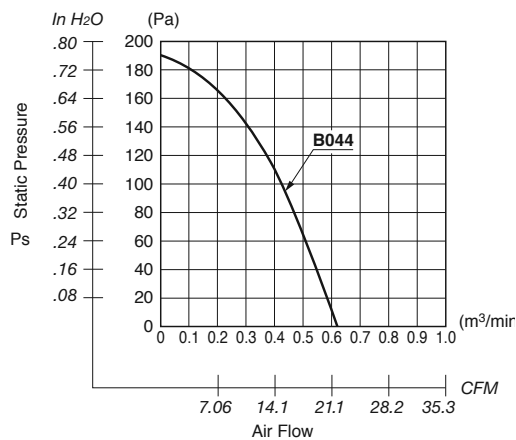

Material

- Casing : Plastic (Black) 94V-0
- Impeller : Plastic (Black) 94V-0
- Bearing : Ball Bearing
- Lead Wire : UL1007, AWG26, +Red, -Black

Specifications

MODEL	Product No.	Rated Voltage	Operating Voltage	Current	Input Power	Speed	Max. Air Flow		Max. Static Pressure		Noise	Mass
		(V)	(V)	(A) ^{*1}	(W) ^{*1}	(min ⁻¹) ^{*1}	CFM ^{*1}	(m³/min) ^{*1}	in H ₂ O	(Pa) ^{*1}	(dB) ^{*1}	(g)
BG1002-B044-000-	00	12	6 ~ 13.8	0.50	6.7	3300	21.9	0.62	.85	212	48.0	160

Rotation: Clockwise

Airflow Outlet: Air Out Over Struts

*1: Average Values in Free Air

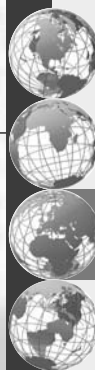

General Specifications

Allowable Ambient Temperature Range:

- 10°C ~ +60°C (65%RH) (Operating)
- 40°C ~ +75°C (65%RH) (Storage)
- (non-condensing environment)

Expected Life

- Failure Rate: 10%
- 30,000 Hours (25°C, 65%RH)

Outline

Units: $\frac{\text{inch}}{\text{mm}}$

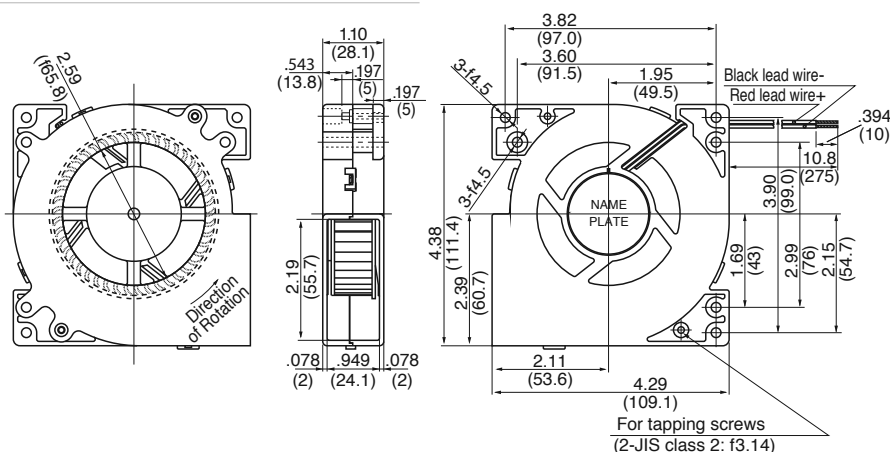

Characteristic Curves

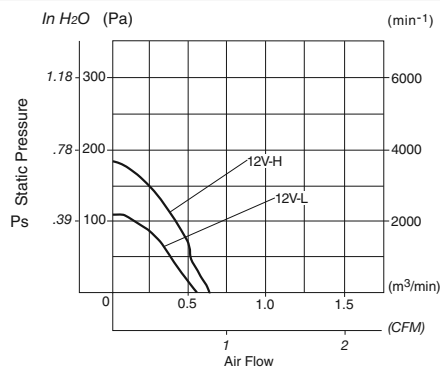

Material

Bearing : Hydro Wave Bearing

Specifications

MODEL	Rated Voltage	Operating Voltage	Current	Input Power	Rated Speed	Max. Air Flow		Max. Static Pressure		Noise	Mass
	(V)	(V)	(A) ^{*1}	(W) ^{*1}	(min ⁻¹) ^{*1}	CFM ^{*1}	(m ³ /min) ^{*1}	in H ₂ O	(Pa) ^{*1}	(dB) ^{*1}	(g)
FAL6F 12LL	12	7.0 ~ 13.8	280	3.36	2100	18.7	0.53	.44	110.3	40.0	250
FAL6F 12LH	12	7.0 ~ 13.8	500	6.00	2550	23.0	0.65	.70	176.5	45.0	250
FAL6F 24LL	24	14.0 ~ 27.6	155	3.72	2100	18.7	0.53	.45	112.8	40.0	250
FAL6F 24LH	24	14.0 ~ 27.6	295	7.08	2550	23.7	0.67	.77	193.2	45.0	250

Rotation: Clockwise

Airflow Outlet: Air Out Over Struts

*1: Average Values in Free Air

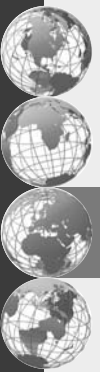

General Specifications

Allowable Ambient Temperature Range:

- 10°C ~ +60°C (Operating)
- 40°C ~ +70°C (Storage)
- (non-condensing environment)

Expected Life

- Failure Rate: 10%
- 25°C 100,000 Hours (00)

Outline

Units: $\frac{\text{inch}}{\text{mm}}$

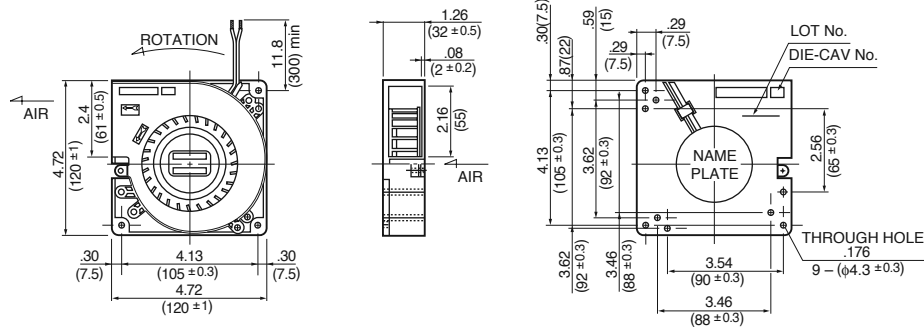

Characteristic Curves

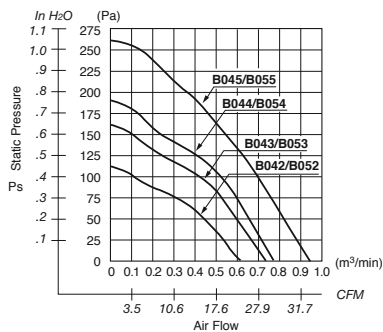

Material

- Casing : Plastic (Black) 94V-0
- Impeller : Plastic (Black) 94V-0
- Bearing : Ball Bearing
- Lead Wire : UL1007, AWG26, +Red, -Black

Specifications

MODEL	Product No.	Rated Voltage	Operating Voltage	Current	Input Power	Speed	Max. Air Flow		Max. Static Pressure		Noise	Mass
		(V)	(V)	(A) ^{*1}	(W) ^{*1}	(min ⁻¹) ^{*1}	CFM ¹	(m ³ /min) ^{*1}	in H ₂ O	(Pa) ^{*1}	(dB) ^{*1}	(g)
BG1203-B042-000-	00	12	6 ~ 13.8	0.30	3.60	1800	22.2	0.63	.40	100	41.5	270
BG1203-B043-000-	00	12	6 ~ 13.8	0.48	5.78	2100	26.1	0.74	.58	145	46.5	270
BG1203-B044-000-	00	12	6 ~ 13.8	0.65	7.80	2250	28.2	0.80	.70	175	48.5	270
BG1203-B045-000-	00	12	6 ~ 13.8	0.93	11.16	2650	33.2	0.94	1.04	260	54.0	270
BG1203-B052-000-	00	24	12 ~ 27.6	0.17	4.08	1800	22.2	0.63	.40	100	41.5	270
BG1203-B053-000-	00	24	12 ~ 27.6	0.25	6.00	2100	26.1	0.74	.56	145	46.5	270
BG1203-B054-000-	00	24	12 ~ 27.6	0.30	7.20	2250	28.2	0.80	.70	175	48.5	270
BG1203-B055-000-	00	24	12 ~ 25.2	0.48	11.52	2650	33.2	0.94	1.04	260	54.0	270

Rotation: Clockwise

Airflow Outlet: Air Out Over Struts

*1: Average Values in Free Air

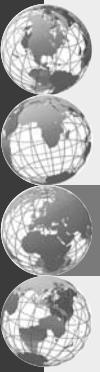

General Specifications

Allowable Ambient Temperature Range:

- 20°C ~ +60°C (Operating)
- 40°C ~ +80°C (Storage)
- (non-condensing environment)

Expected Life

- Failure Rate: 10%
- 25°C 30,000 Hours (P00)

Outline

Units: $\frac{\text{inch}}{\text{mm}}$

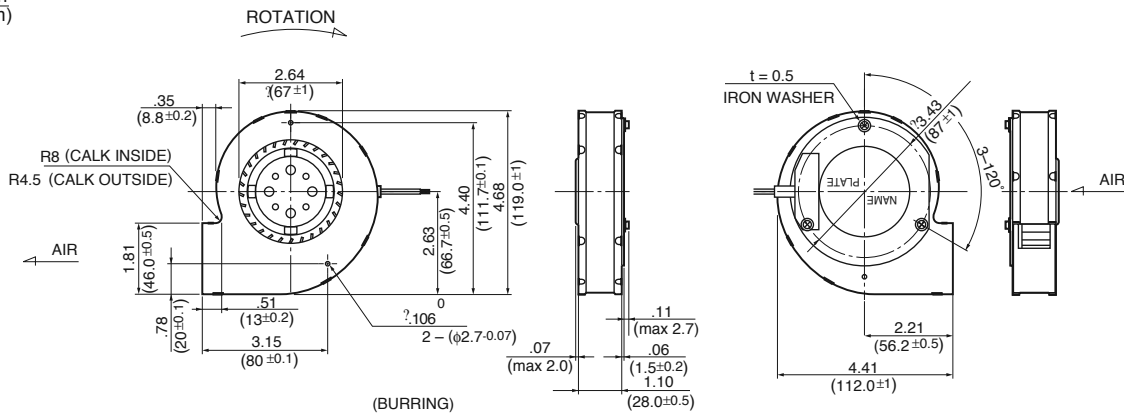

Characteristic Curves

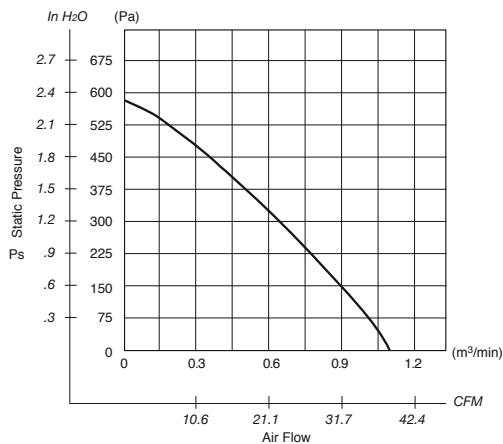

Material

- Casing : Steel
- Impeller : PBT Glass 30%
- Bearing : Ball Bearing
- Lead Wire : UL1007, AWG22, +Red, -Black

Specifications

MODEL	Rated Voltage	Operating Voltage	Current	Input Power	Speed	Max. Air Flow		Max. Static Pressure		Noise	Mass	
	(V)	(V)	(A) ^{*1}	(W) ^{*1}	(min ⁻¹) ^{*1}	CFM ^{*1}	(m ³ /min) ^{*1}	in H ₂ O	(Pa) ^{*1}	(dB) ^{*1}	(g)	
BL4447-04W-B40-	X00	12	6 ~ 13	1.70	20.4	4400	38.8	1.10	2.25	560	65.0	300

Rotation: Clockwise

Airflow Outlet: Air Out Over Struts

*1: Average Values in Free Air



Common Specifications

- Operating Voltage:.....Rated voltage +/- 10%
- Noise:Measured at 1 meter from the side of the fan at the rated voltage
- Vibration Test:..... JIS C 60068-2-6
- Shock Test:..... JIS C 60068-2-27
- Insulation Class: E class (UL: Class A)
- Protection: Motor burnout is prevented by the impedance protection system or the thermal protection system.
- Impedance Protection System:..... The motor coil impedance limits motor temperature within the insulation class specification.
- Thermal Protection System: The coil includes a thermal cut-out to limit motor temperature within the insulation class specification.

Notes: Additional performance requirements can be determined between manufacturer and customer, based on customer's request. Ball bearing fans may be installed in a horizontal, vertical or angled position.

Part Numbering System

47 15 P S - 12 T - B 2 0 - A 00
 (1) (2) (3) (4) (5) (6) (7) (8) (9) (10) (11)

- | | | | |
|--|--|---|--|
| <p>1. Frame Size
 24: 60mm
 31: 80mm
 36: 92mm
 47: 119mm
 59: 150mm</p> <p>2. Frame Thickness
 10: 25mm
 12: 30mm
 15: 38mm</p> <p>3. Series
 P Series
 M Series
 F Series</p> | <p>4. Motor Function
 S: Shaded Pole
 C: Capacitor Run</p> <p>5. Input Voltage
 100V Class
 10: 100V
 12: 115V
 200V Class
 20: 200V
 22: 220V
 23: 230V
 24: 240V</p> | <p>6. Termination
 W: Lead Wires
 T: Terminal</p> <p>7. Bearing
 B: Ball Bearing</p> <p>8. Speed
 1<2<3<4<5
 low high</p> <p>9. Protection
 0: Impedance Protected
 A: Thermal Protected
 (including 5915PC B30 only)</p> | <p>10. Product Number
 A: Standard 115V, 230V & 240V
 B: Standard 100V, 200V & 220V
 D: Custom Casing 115V-230V
 K: Frameless</p> <p>11. Individual Specification
 00: Standard
 01~99: Custom</p> |
|--|--|---|--|



General Specifications

Motor Structure: Shaded Pole Induction Motor
Motor Protection: Impedance Protection
Allowable Ambient Temperature Range:
 -10°C ~ +70°C (Operating)
 -40°C ~ +70°C (Storage)
 (non-condensing environment)

Expected Life

Failure Rate: 10%
 25°C 50,000 Hours

Outline

Units: $\frac{\text{inch}}{\text{mm}}$

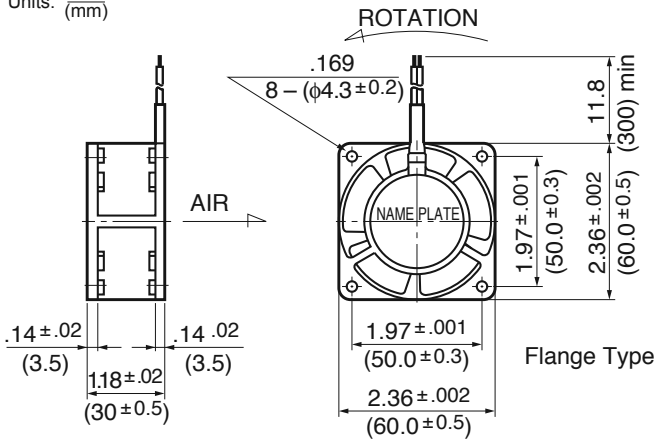

Characteristic Curves

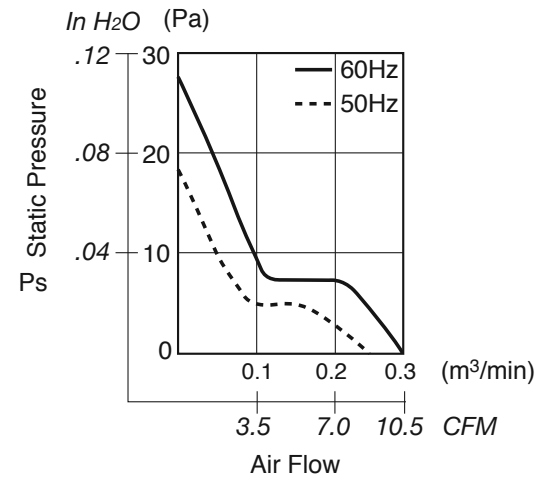

Panel Cut-outs

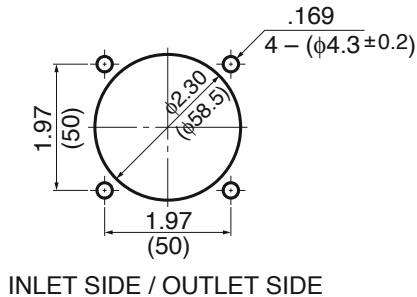

Material

Casing : Aluminum
 Impeller : Polycarbonate (Glass Fiber-Containing)
 Bearing : Ball Bearing
 Lead Wire: UL3266, CSA CL1252, AWG22

Specifications

MODEL	Rated Voltage	Frequency	Starting Voltage	Current	Input Power	Speed	Max. Air Flow		Max. Static Pressure		Noise	Mass
	(V)	(Hz)	(V)	(A) ^{*1}	(W) ^{+10% -20%}	(min ⁻¹) ^{*3}	CFM ^{*2}	(m ³ /min) ^{*3}	in H ₂ O	(Pa) ^{*3}	(dB) ^{*2}	(g)
2412PS-12W-B30-A00	115	50	65	0.070	4.5	2000	7.0	0.20	.05	13.7	28	140
	115	60	65	0.060	4.0	2600	9.1	0.26	.09	22.6	29	140

Rotation: Clockwise

Airflow Outlet: Air Out Over Struts

*1: Average Values in Free Air



General Specifications

Motor Structure: Shaded Pole Induction Motor
Motor Protection: Impedance Protection
Allowable Ambient Temperature Range:
 -10°C ~ +70°C (Operating)
 -40°C ~ +70°C (Storage)
 (non-condensing environment)

Expected Life

Failure Rate: 10%
 25°C 50,000 Hours

Outline

Units: $\frac{\text{inch}}{\text{mm}}$

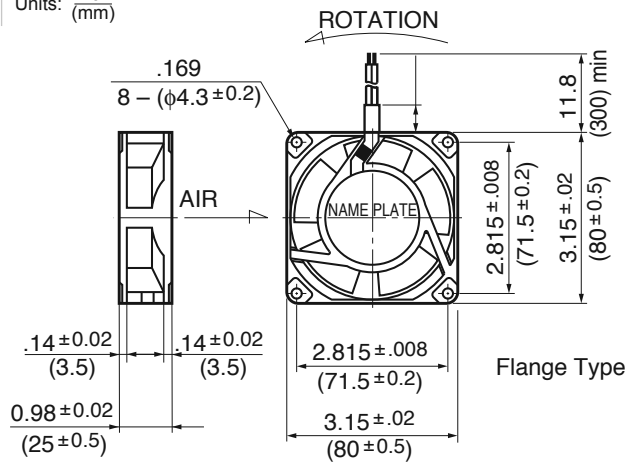

Characteristic Curves

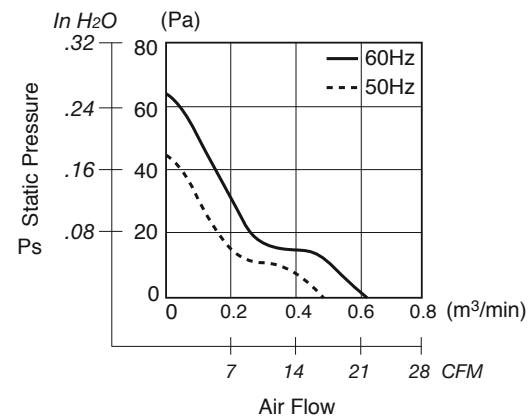

Panel Cut-outs

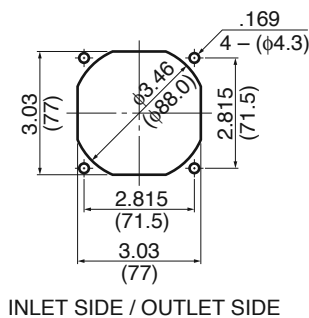

Material

Casing : Aluminum
 Impeller : Polycarbonate (Glass Fiber-Containing)
 Bearing : Ball Bearing
 Lead Wire: UL3266, CSA CL1252, AWG22

Specifications

MODEL	Rated Voltage	Frequency	Starting Voltage	Current	Input Power	Speed	Max. Air Flow		Max. Static Pressure		Noise	Mass
	(V)	(Hz)	(V)	(A) ^{*1}	(W) ^{+10% -20%}	(min ⁻¹) ^{*3}	CFM ^{*2}	(m ³ /min) ^{*3}	in H ₂ O	(Pa) ^{*3}	(dB) ^{*2}	(g)
3110PS-12W-B30-A00	115	50	65	0.085	6.0	2600	16.2	0.46	.15	39.2	28	220
	115	60	65	0.075	5.0	3100	19.7	0.56	.21	53.9	33	220

Rotation: Clockwise

Airflow Outlet: Air Out Over Struts

*1: Average Values in Free Air



General Specifications

Motor Structure: Shaded Pole Induction Motor
Motor Protection: Impedance Protection
Allowable Ambient Temperature Range:
 -10°C ~ +70°C (Operating)
 -40°C ~ +70°C (Storage)
 (non-condensing environment)

Expected Life

Failure Rate: 10%
 25°C 50,000 Hours

Outline

Units: $\frac{\text{inch}}{\text{mm}}$

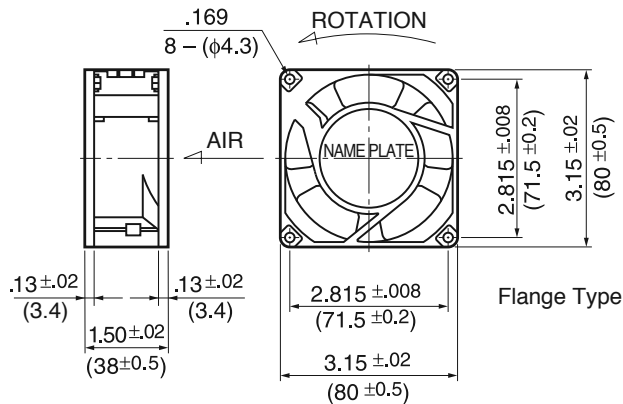

Characteristic Curves

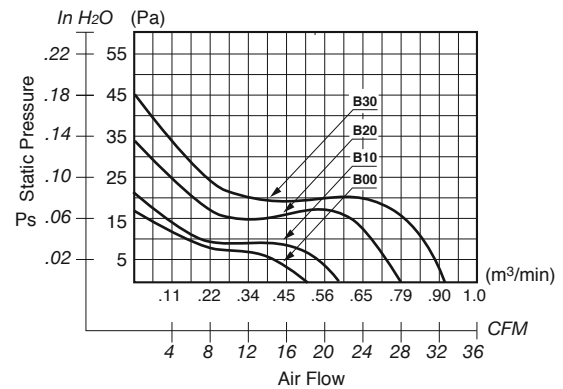

Panel Cut-outs

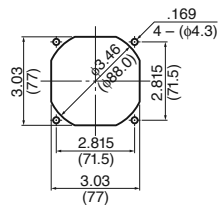

INLET SIDE / OUTLET SIDE

Material

Casing : Aluminum
 Impeller : UL94V-O Reinforced Plastic
 Bearing : Ball Bearing
 Lead Wire : AWG22, UL3266, CSA CL1252
 or Terminal : Faston #110 or equivalent

Specifications

MODEL	Rated Voltage	Frequency	Starting Voltage	Current	Input Power	Speed	Max. Air Flow		Max. Static Pressure		Noise	Mass
	(V)	(Hz)	(V)	(A) ^{*1}	(W) ^{*1}	(min ⁻¹) ^{*1}	CFM ^{*1}	(m ³ /min) ^{*1}	in H ₂ O	(Pa) ^{*1}	(dB) ^{*1}	(g)
3115FS-12T-B00-A00	115	60	75	0.045	4.0	1850	18.0	0.51	.07	17.5	31	340
3115FS-12T-B10-A00	115	60	75	0.087	6.5	2100	22.0	0.62	.09	22.5	36	340
3115FS-12T-B20-A00	115	60	75	0.090	7.5	2700	27.0	0.76	.13	32.5	40	340
3115FS-12T-B30-A00	115	60	75	0.100	8.5	3250	32.0	0.90	.18	45.0	44	340
3115FS-23T-B10-A00	230	60	175	0.050	6.5	2050	20.0	0.57	.09	22.5	35	340
3115FS-23T-B20-A00	230	60	175	0.060	7.5	2750	28.0	0.79	.13	32.5	40	340
3115FS-23T-B30-A00	230	60	175	0.065	8.0	3250	33.0	0.93	.18	45.0	44	340

Rotation: Clockwise

Airflow Outlet: Air Out Over Struts

*1: Average Values in Free Air



General Specifications

Motor Structure: Shaded Pole Induction Motor

Motor Protection: Impedance Protection

Allowable Ambient Temperature Range:

-10°C ~ +70°C (Operating)

-40°C ~ +70°C (Storage)

(non-condensing environment)

Expected Life

Failure Rate: 10%

25°C 50,000 Hours

Outline

Units: $\frac{\text{inch}}{\text{mm}}$

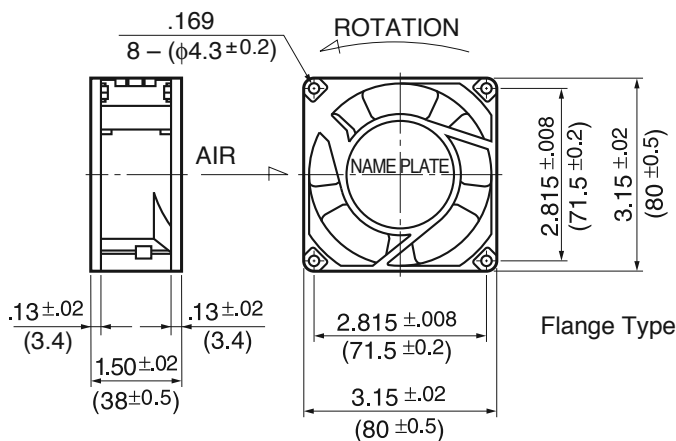

Characteristic Curves

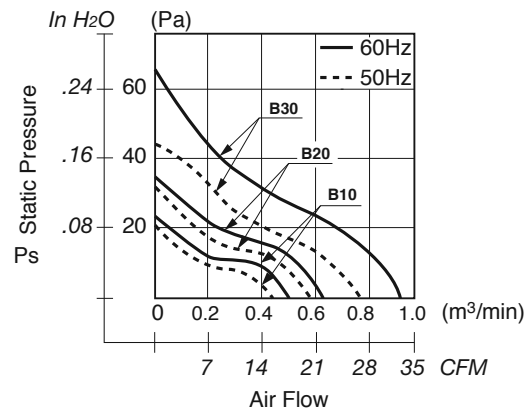

Panel Cut-outs

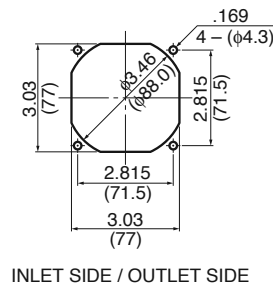

Material

- Casing : Aluminum
- Impeller : Polycarbonate
(Glass Fiber-Containing)
- Bearing : Ball Bearing
- Lead Wire : AWG22, UL3266, CSA CL1252
- or Terminal : Faston #110 or equivalent

Specifications

MODEL	Rated Voltage	Frequency	Starting Voltage	Current	Input Power	Speed	Max. Air Flow		Max. Static Pressure		Noise	Mass
	(V)	(Hz)	(V)	(A) ^{*1}	(W) ^{+10% -20%}	(min ⁻¹) ³	CFM ²	(m ³ /min) ³	in H ₂ O	(Pa) ³	(dB) ²	(g)
3115PS-12T-B30-A00	115	50	75	0.140	9.0	2700	26.5	0.75	.14	34.3	33.0	270
	115	60	75	0.110	7.0	3200	32.0	0.90	.20	49.0	38.0	270
3115PS-23T-B30-A00	230	50	150	0.070	10.0	2700	26.5	0.75	.14	34.3	33.0	270
	230	60	150	0.055	8.0	3200	32.0	0.90	.20	49.0	38.0	270
3115PS-12T-B20-A00	115	50	75	0.080	5.0	2100	21.0	0.60	.10	24.5	29.0	270
	115	60	75	0.070	4.5	2300	24.0	0.68	.12	29.4	32.0	270
3115PS-23T-B20-A00	230	50	150	0.050	7.0	2200	22.0	0.63	.10	24.5	30.0	270
	230	60	150	0.045	6.0	2500	26.0	0.74	.14	35.2	34.0	270
3115PS-12T-B10-A00	115	50	75	0.060	4.5	1700	17.6	0.50	.06	16.6	23.0	270
	115	60	75	0.055	4.0	1900	19.4	0.55	.08	21.5	25.0	270
3115PS-23T-B10-A00	230	50	150	0.055	6.0	1800	17.6	0.50	.07	17.6	23.0	270
	230	60	150	0.050	5.0	2100	22.0	0.63	.10	24.5	26.0	270

Rotation: Clockwise

Airflow Outlet: Air Out Over Struts

*1: Average Values in Free Air



General Specifications

Motor Structure: Shaded Pole Induction Motor

Motor Protection: Impedance Protection

Allowable Ambient Temperature Range:

-10°C ~ +70°C (Operating)

-40°C ~ +70°C (Storage)

(non-condensing environment)

Expected Life

Failure Rate: 10%

25°C 50,000 Hours

Outline

Units: $\frac{\text{inch}}{\text{mm}}$

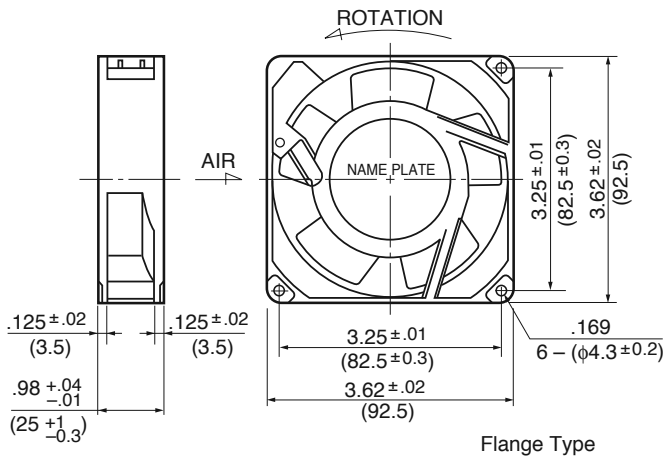

Characteristic Curves

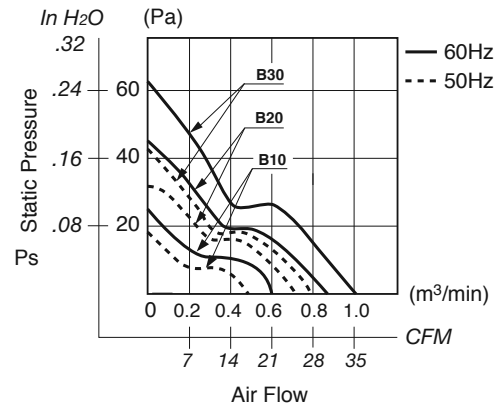

Panel Cut-outs

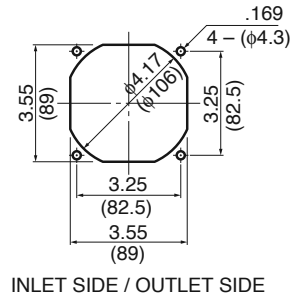

Material

- Casing : Aluminum
- Impeller : Polycarbonate
(Glass Fiber-Containing)
- Bearing : Ball Bearing
- Lead Wire : AWG22, UL3266, CSA CL1252
- or Terminal : Faston #110 or equivalent

Specifications

MODEL	Rated Voltage	Frequency	Starting Voltage	Current	Input Power	Speed	Max. Air Flow		Max. Static Pressure		Noise	Mass
	(V)	(Hz)	(V)	(A) ^{*1}	(W) ^{+10% -20%}	(min ⁻¹) ³	CFM ²	(m ³ /min) ³	in H ₂ O	(Pa) ³	(dB) ²	(g)
3610PS-12T-B30-A00	115	50	75	0.170	12.0	2600	28.0	0.80	.17	43.1	33.5	300
	115	60	75	0.130	9.0	3100	34.5	0.98	.24	60.7	38.0	300
3610PS-23T-B30-A00	230	50	180	0.090	13.0	2600	28.0	0.80	.17	43.1	34.0	300
	230	60	180	0.070	10.0	3100	34.5	0.98	.24	60.7	39.0	300
3610PS-12T-B20-A00	115	50	75	0.095	7.0	2100	21.0	0.60	.12	29.4	30.0	300
	115	60	75	0.090	6.0	2500	28.0	0.80	.16	39.2	35.0	300
3610PS-23T-B20-A00	230	50	180	0.050	7.0	2100	21.0	0.60	.12	29.4	30.0	300
	230	60	180	0.050	6.0	2500	28.0	0.80	.16	39.2	35.0	300
3610PS-12T-B10-A00	115	50	75	0.090	7.0	1450	16.0	0.46	.05	13.7	22.0	300
	115	60	75	0.080	6.0	1800	20.0	0.58	.08	19.6	25.0	300
3610PS-23T-B10-A00	230	50	180	0.050	7.0	1450	16.0	0.46	.05	13.7	22.0	300
	230	60	180	0.040	6.0	1800	20.0	0.58	.08	19.6	26.0	300

Rotation: Clockwise

Airflow Outlet: Air Out Over Struts

*1: Average Values in Free Air



General Specifications

Motor Structure: Shaded Pole Induction Motor

Motor Protection: Impedance Protection

Allowable Ambient Temperature Range:

-10°C ~ +70°C (Operating)

-40°C ~ +70°C (Storage)

(non-condensing environment)

Expected Life

Failure Rate: 10%

25°C 50,000 Hours

Outline

Units: $\frac{\text{inch}}{\text{mm}}$

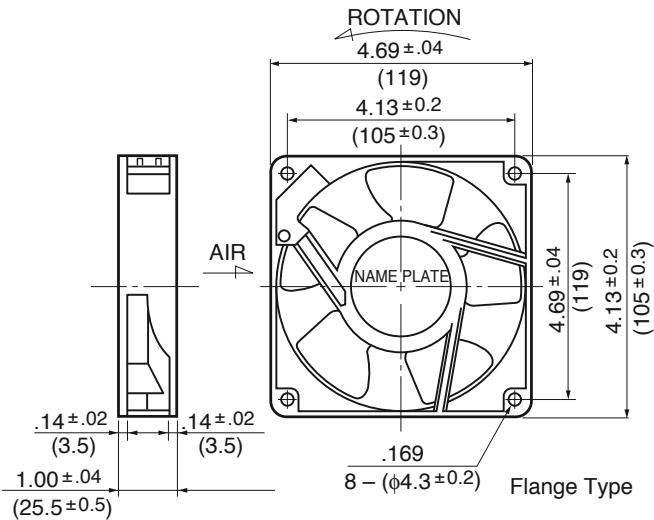

Characteristic Curves

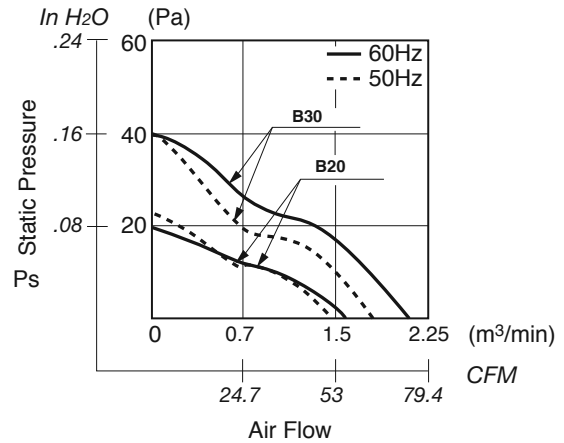

Panel Cut-outs

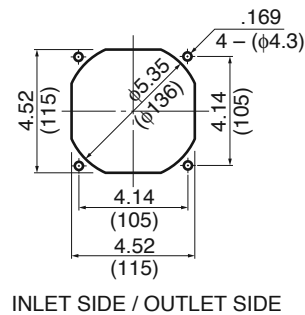

Material

- Casing : Aluminum
- Impeller : Polycarbonate (Glass Fiber-Containing)
- Bearing : Ball Bearing
- Terminal : Faston #110 or equivalent

Specifications

MODEL	Rated Voltage	Frequency	Starting Voltage	Current	Input Power	Speed	Max. Air Flow		Max. Static Pressure		Noise	Mass
	(V)	(Hz)	(V)	(A) ¹	(W) ^{+10% -20%}	(min ⁻¹) ³	CFM ²	(m ³ /min) ³	in H ₂ O	(Pa) ³	(dB) ²	(g)
4710PS-12T-B30-A00	115	50	75	0.190	14.0	2300	63.5	1.80	.16	41.1	34.0	360
	115	60	75	0.160	11.0	2700	70.6	2.00	.16	41.1	38.0	360
4710PS-23T-B30-A00	230	50	175	0.100	14.0	2300	63.5	1.80	.16	41.1	34.0	360
	230	60	175	0.090	11.0	2700	70.6	2.00	.16	41.1	38.0	360
4710PS-12T-B20-A00	115	50	75	0.100	8.0	1900	49.4	1.40	.09	23.5	29.0	360
	115	60	75	0.090	7.0	2000	53.0	1.50	.08	21.5	30.0	360
4710PS-23T-B20-A00	230	50	175	0.060	9.0	1900	49.4	1.40	.09	23.5	29.0	360
	230	60	175	0.050	8.0	2100	53.0	1.50	.08	21.5	30.0	360

Rotation: Clockwise

Airflow Outlet: Air Out Over Struts

*1: Average Values in Free Air



General Specifications

Motor Structure: Shaded Pole Induction Motor
Motor Protection: Impedance Protection
Allowable Ambient Temperature Range:
 -10°C ~ +70°C (Operating)
 -40°C ~ +70°C (Storage)
 (non-condensing environment)

Expected Life

Failure Rate: 10%
 25°C 50,000 Hours

Outline

Units: $\frac{\text{inch}}{\text{mm}}$

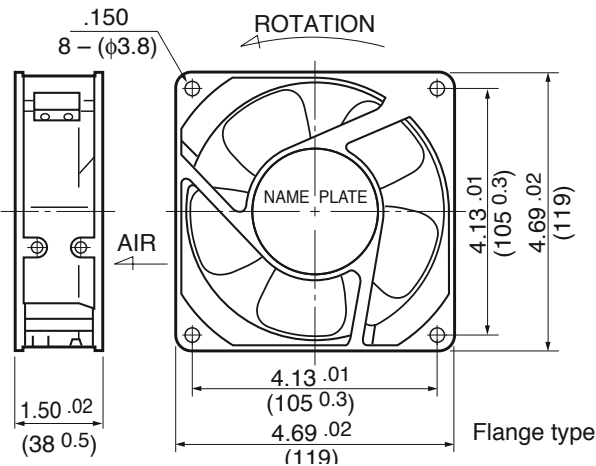

Panel Cut-outs

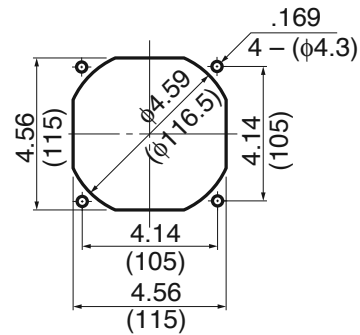

INLET SIDE / OUTLET SIDE

Material

Casing : Aluminum Alloy
 Impeller : UL94V-O Reinforced Plastic
 Bearing : Ball Bearing
 Lead Wire : AWG22, UL3266, CSA CL1252
 or Terminal : Faston #110 or equivalent

Specifications

MODEL	Rated Voltage	Frequency	Starting Voltage	Current	Input Power	Speed	Max. Air Flow		Max. Static Pressure		Noise	Mass
	(V)	(Hz)	(V)	(A) ^{*1}	(W) ^{*1}	(min ⁻¹) ^{*1}	CFM ^{*1}	(m ³ /min) ^{*1}	in H ₂ O	(Pa) ^{*1}	(dB) ^{*1}	(g)
4715FS-12T-B00-D00	115	60	75	0.090	7.5	1700	60.0	1.70	.08	20.0	31	550
4715FS-12T-B10-D00	115	60	75	0.110	10.0	1900	70.0	1.98	.12	30.0	33	550
4715FS-12T-B20-D00	115	60	75	0.100	9.8	2300	80.0	2.25	.13	32.5	36	550
4715FS-12T-B30-D00	115	60	75	0.180	14.5	2650	90.0	2.50	.22	55.0	39	550
4715FS-12T-B40-D00	115	60	75	0.170	14.0	2800	100.0	2.80	.29	72.5	42	550
4715FS-12T-B50-D00	115	60	75	0.190	14.4	3100	110.0	3.10	.37	92.5	45	550
4715FS-23T-B00-D00	230	60	175	0.030	5.5	1600	55.0	1.50	.07	17.5	30	550
4715FS-23T-B10-D00	230	60	175	0.050	9.0	1900	70.0	1.98	.12	30.0	33	550
4715FS-23T-B20-D00	230	60	175	0.050	8.8	2300	80.0	2.25	.13	32.5	36	550
4715FS-23T-B30-D00	230	60	175	0.090	12.0	2650	90.0	2.50	.22	55.0	39	550
4715FS-23T-B40-D00	230	60	175	0.090	14.0	2800	100.0	2.80	.28	70.0	42	550
4715FS-23T-B50-D00	230	60	175	0.080	14.0	3100	110.0	3.10	.37	92.5	45	550

Rotation: Clockwise

Airflow Outlet: Air Out Over Struts

*1: Average Values in Free Air



General Specifications

Motor Protection:

Auto Restart/Polarity Protection

Insulation Resistance:

10M Ω or over with a DC500V Megger

Dielectric Withstand Voltage: AC 700V 1s

Allowable Ambient Temperature Range:

-10°C ~ +70°C (Operating)

-40°C ~ +70°C (Operating)

(non-condensing environment)

Expected Life

Failure Rate: 10%

25°C 50,000 Hours

Outline

Units: $\frac{\text{inch}}{\text{mm}}$

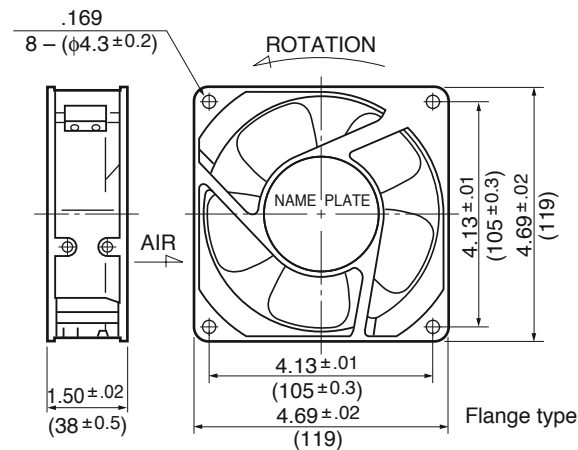

Panel Cut-outs

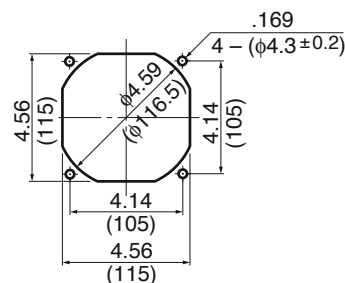

Material

Casing	: Aluminum
Impeller	: Polycarbonate (Glass Fiber-Containing)
Bearing	: Ball Bearing
Lead Wire	: AWG22, UL3266, CSA CLR52
or Terminal	: Faston #110 or equivalent

Characteristic Curves

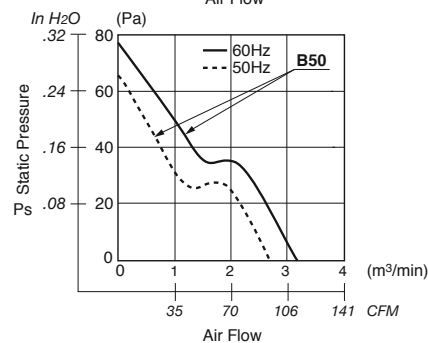
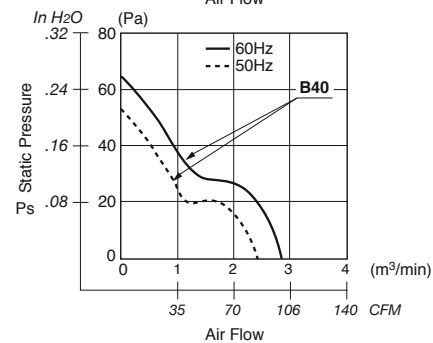
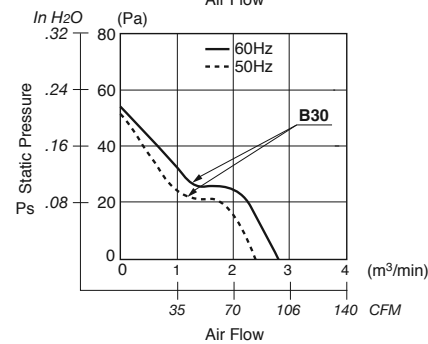
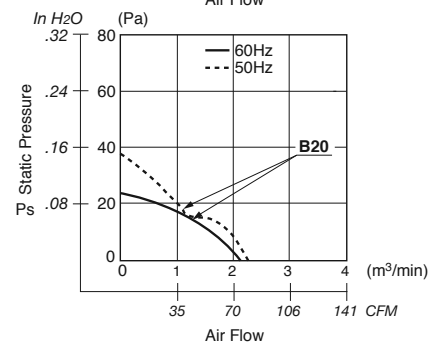
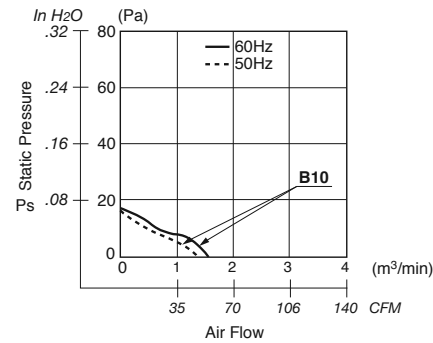



Specifications

MODEL	Rated Voltage	Frequency	Starting Voltage	Current	Input Power	Speed	Max. Air Flow		Max. Static Pressure		Noise	Mass
	(V)	(Hz)	(V)	(A) ^{*1}	(W) ^{+10% -20%}	(min ⁻¹) ³	CFM ^{*2}	(m ³ /min) ^{*3}	in H ₂ O	(Pa) ^{*3}	(dB) ^{*2}	(g)
4715MS-12T-B50-A00	115	50	65	0.250	15.5	2600	88.2	2.50	.259	64.6	37.0	550
	115	60	65	0.210	14.5	2900	102.0	2.90	.309	76.4	41.0	550
4715MS-23T-B50-A00	230	50	175	0.120	15.0	2600	88.2	2.50	.255	63.7	37.0	550
	230	60	175	0.100	14.0	2900	102.0	2.90	.283	70.5	41.0	550
4715MS-12T-B40-A00	115	50	75	0.220	15.0	2450	85.0	2.40	.204	50.9	35.0	550
	115	60	75	0.190	13.0	2750	95.0	2.70	.259	64.6	39.0	550
4715MS-23T-B40-A00	230	50	175	0.120	15.0	2450	85.0	2.40	.216	53.9	35.0	550
	230	60	175	0.100	13.0	2750	95.0	2.70	.255	63.7	39.0	550
4715MS-12T-B30-A00	115	50	75	0.160	11.0	2400	81.0	2.30	.200	49.9	34.0	550
	115	60	75	0.140	10.0	2600	88.2	2.50	.200	49.9	37.0	550
4715MS-23T-B30-A00	230	50	175	0.100	12.0	2400	81.0	2.30	.197	49.0	34.0	550
	230	60	175	0.080	11.0	2600	88.2	2.50	.208	51.9	37.0	550
4715MS-12T-B20-A00	115	50	75	0.100	7.0	2100	76.6	2.00	.141	35.2	32.0	550
	115	60	75	0.100	7.0	1950	67.0	1.90	.098	24.5	30.0	550
4715MS-23T-B20-A00	230	50	175	0.060	7.5	2100	70.6	2.00	.141	35.2	32.0	550
	230	60	175	0.060	7.5	1900	67.0	1.90	.086	21.5	30.0	550
4715MS-12T-B10-A00	115	50	75	0.090	6.0	1350	45.9	1.30	.062	15.6	27.0	550
	115	60	75	0.080	5.5	1450	49.4	1.40	.066	16.6	28.0	550
4715MS-23T-B10-A00	230	50	175	0.050	6.5	1350	45.9	1.30	.059	14.7	27.0	550
	230	60	175	0.045	6.0	1450	49.4	1.40	.059	14.7	28.0	550

Rotation: Clockwise

Airflow Outlet: Air Out Over Struts

*1: Average Values in Free Air



General Specifications

Motor Structure: Shaded Pole Induction Motor

Motor Protection: Impedance Protection

Allowable Ambient Temperature Range:

-10°C ~ +70°C (Operating)

-40°C ~ +70°C (Storage)

(non-condensing environment)

Expected Life

Failure Rate: 10%

25°C 50,000 Hours

Outline

Units: $\frac{\text{inch}}{\text{mm}}$

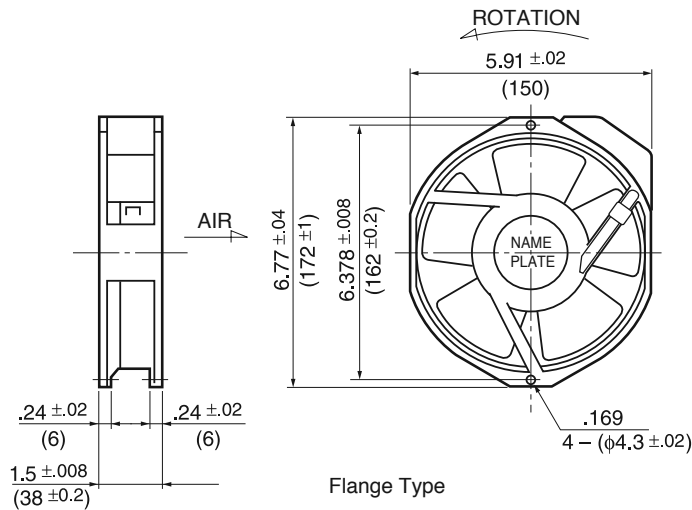

Characteristic Curves

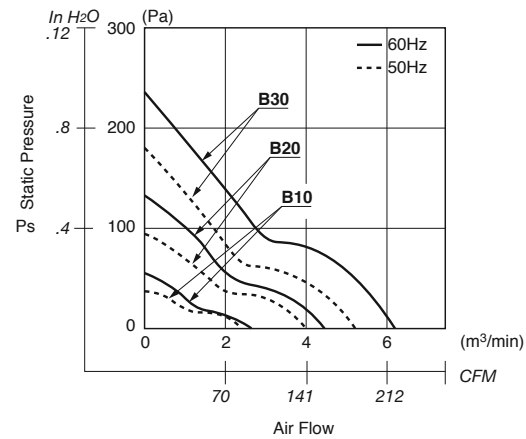

Panel Cut-outs

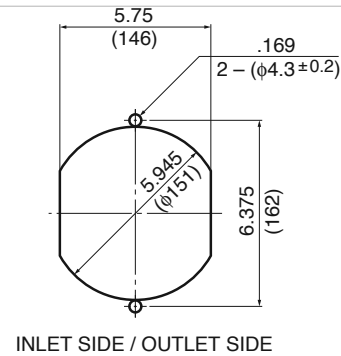

Material

- Casing : Aluminum
- Impeller : Polycarbonate (Glass Fiber-Containing)
- Bearing : Ball Bearing
- Terminal : Faston #110 or equivalent

Specifications

MODEL	Rated Voltage	Frequency	Starting Voltage	Current	Input Power	Speed	Max. Air Flow		Max. Static Pressure		Noise	Mass
	(V)	(Hz)	(V)	(A) ^{*1}	(W) ^{+10% -20%}	(min ⁻¹) ^{*3}	CFM ^{*2}	(m ³ /min) ^{*3}	in H ₂ O	(Pa) ^{*3}	(dB) ^{*2}	(g)
5915PC-12T-B30-A00	115	50	75	0.380	35.0	2700	176.5	5.00	.629	156.8	52.0	800
	115	60	75	0.360	32.0	3200	212.0	6.00	.865	215.6	56.0	800
5915PC-23T-B30-A00	230	50	145	0.180	35.0	2700	176.5	5.00	.629	156.8	52.0	800
	230	60	145	0.190	35.0	3200	212.0	6.00	.865	215.6	56.0	800
5915PC-12T-B20-A00	115	50	75	0.200	21.0	2200	141.2	4.00	.393	98.0	46.0	800
	115	60	75	0.210	22.0	2600	166.0	4.70	.472	117.6	50.0	800
5915PC-23T-B20-A00	230	50	145	0.120	23.0	2200	141.2	4.00	.393	98.0	46.0	800
	230	60	145	0.140	26.0	2600	166.0	4.70	.472	117.6	50.0	800
5915PC-12T-B10-A00	115	50	75	0.160	16.0	1400	84.7	2.40	.173	43.1	35.0	800
	115	60	75	0.190	18.0	1650	102.3	2.90	.243	60.7	38.0	800
5915PC-23T-B10-A00	230	50	145	0.090	16.0	1400	84.7	2.40	.168	42.1	35.0	800
	230	60	145	0.110	18.0	1650	102.3	2.90	.243	60.7	38.0	800

Rotation: Clockwise

Airflow Outlet: Air Out Over Struts

*1: Average Values in Free Air



FAN MODEL	UL E89936	CSA LR65829	VDE	TUV	CE
1004KL	Vol. 1, S44	1087445	15073-0023		X
1204KL	Vol. 1, S37	1223044	15073-0013		X
1404KL	Vol. 1, S45	1065707	15073-0032		
1604KL	Vol. 1, S40	1141408	15073-0008		X
1606KL	Vol. 1, S32	1255295	15073-0008		X
1608KL	Vol. 1, S32	1278193	15073-0022		X
2004KL	Vol. 1, S43	1144468	15073-0017		X
2106KL	Vol. 1, S32	1255295	15073-0018		X
2404KL	Vol. 1, S61	1146135			
2406KL	Vol. 1, S38	2500002888	15073-0020		X
2408NL	Vol. 1, S34	1309625	15073-0013		X
2410ML	Vol. 1, S33	1193855			X
2415KL	Vol. 1, S94		15073-0067		
2810KL	Vol. 1, S65	1188649	15073-0008		
3106KL	Vol. 1, S46	1038727	15073-0033		
3108NL	Vol. 1, S29	1309625	15073-0016		X
3110KL	Vol. 1, S35	1309625	15073-0008		X
3112KL	Vol. 1, S35	1309625	15073-0008		
3610KL	Vol. 1, S31	1309625	15073-0008		X
3612KL	Vol. 1, S52	1253246	15073-0008		X
3615KL	Vol. 1, S51	1195298	15073-0008		X
FBA10J12L					
4710KL	Vol. 1, S64	1174022	15073-0049		
4712FL	Vol. 1, S55	1143199	15073-0045		
4712KL	Vol. 1, S41	1143199	15073-0008		X
4715KL	Vol. 1, S36	-164	15073-0008		X
4715SL	Vol. 1, S67	1197651	15073-0058		X
FBA10B14L					
FBA11J10M/14L					
FBA12J12M					
5015KL	Vol. 1, S58		15073-0024		
5020KL					
FBX14	Vol. 1, S113			R50063887	
5910PL	Vol. 1, S74	1285829	15073-0034		X
5920PL	Vol. 1, S30	1285831	15073-0044		X
6820PL	Vol. 1, S30	1285831	15073-0044		X
BM4515	Vol. 1, S62	1161575			
FAL3F	Vol. 1, S114	099935			
BM5115	Vol. 1, S50	1057185	15073-0030		X
BM5125	Vol. 1, S53	1082756	15073-0022		X
BM6015		1082756			
BM6025	Vol. 1, S103		15073-0075		
BG0702	Vol. 1, S63	1133535			
BG0703	Vol. 1, S42	-158	15073-0019		X
FAL5F	Vol. 1, S114	099935			
BG0801	Vol. 1, S98		15073-0019		
BG0903	Vol. 1, S59	1120644	15073-0039		
BG1002	Vol. 1, S60	1158481			
FAL6F	Vol. 1, S114	099935			
BG1203	Vol. 1, S49	1031559	15073-0029		X
BL4447	Vol. 1, S77				
DC Motorized Impellers					
175R Series	Vol. 1, S87				
101R057D07	Vol. 1, S109				
190R071D073XAXX	Vol. 1, S80		15073-0057		
220R071D053XAXX	Vol. 1, S107		15073-0057		X
220R071D0731A01	Vol. 1, S107		15073-0057		X
220R071D0901A01	Vol. 1, S107				
225R099D053XAXX	Vol. 1, S107		15073-0057		X
225R099D073XAXX	Vol. 1, S107		15073-0057		X
250R100D052XAXX	Vol. 1, S80		15073-0057		X
250R100D072XAXX	Vol. 1, S80		15073-0057		
280R125D052XAXX	Vol. 1, S71		15073-0057		X
250R125D072XAXX	Vol. 1, S71		15073-0057		X
AC Series Fan					
2412PS	Vol. 1, S3	1202307	15073-1014		X
3110PS	Vol. 1, S3	1202307		R0030033	X
3115FS	Vol. 1, S28	-19	15073-0015	R0030030	X
3115PS	Vol. 1, S3	1202307	15073-0015		X
3610PS	Vol. 1, S3	1202307	15073-0006	R9072371.1	X
4710PS	Vol. 1, S3	1202307	15073-0009		X
4715FS	Vol. 1, S27	1417267		R30034	
4715MS	Vol. 1, S6	-10	15073-0011		X
5915PC	Vol. 2, S1	1202307	15073-0012		X



15073-3250-1001





THERMAL DESIGN

The need for forced-air cooling should be determined at an early stage in system design. It is important that the design plans for good airflow to heat-generating components and also allows adequate space and power for the cooling fan.

The first stage in designing a forced-air cooling system is to estimate the required airflow. This depends on the heat generated within the enclosure and the maximum temperature rise permitted.

In the following graph, the vertical axis represents the heat to be removed and the horizontal axis represents the airflow; both axes are logarithmic. The sloping lines define the temperature rise in °C. To use the graph, find the sloping line that represents the permitted temperature rise. Then, find the point on this line that corresponds to the heat to be removed. The horizontal position of this point shows the airflow required.

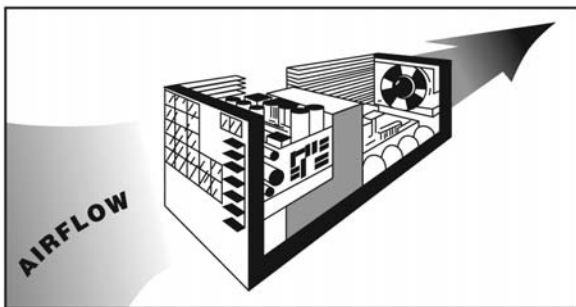

Enclosure with Cover Removed

The airflow required can be obtained either by calculation or from a graph. The equation for calculation is:

$$Q_1 = \frac{0.05 H}{\Delta T} \qquad Q_2 = \frac{1.76 H}{\Delta T}$$

Where:

Q_1 = Airflow required in m³/min

Q_2 = Airflow required in cubic feet/min

H = Heat dissipated in watts

ΔT = Temperature rise above inlet temp °C

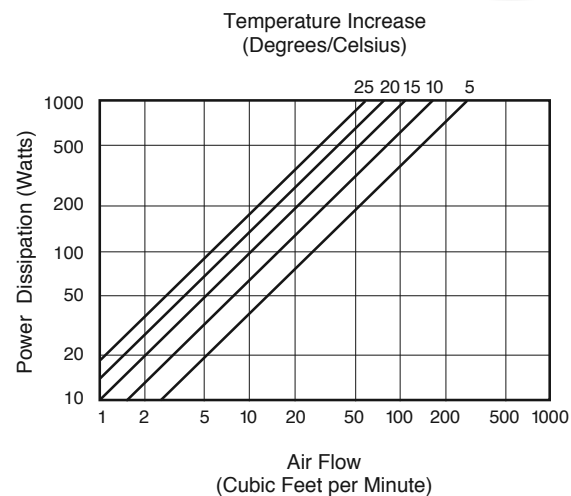

Power Dissipation vs. Airflow for Various Temperature Increases

SYSTEM IMPEDANCE & OPERATING POINT

Obstructions in the airflow path cause static pressure within the enclosure. To achieve maximum airflow, obstructions should be minimized. However, obstructions in the form of baffles may be necessary to direct the airflow over the components that need cooling.

The figures below show the nonlinear relationship between airflow and static pressure for a typical fan. The System Impedance Curve is a property inherent to an individual electronics enclosure. This curve can easily be generated experimentally, by testing the enclosure pressure at various airflow rates. The performance of a fan in a specific application is determined by the intersection of the System Impedance Curve and the Fan Characteristic Curve.

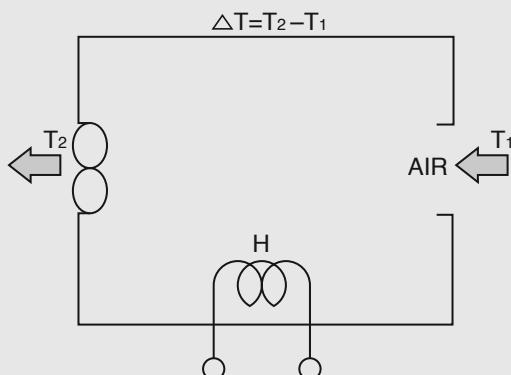



SYSTEM IMPEDANCE & OPERATING POINT (continued)

Chart 2.1

Typical relationship between Airflow and Static pressure for an Axial cooling fan.

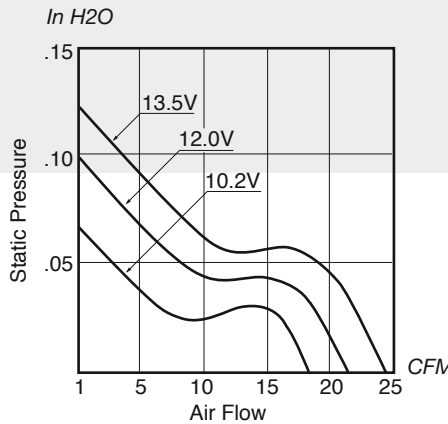

Chart 2.2

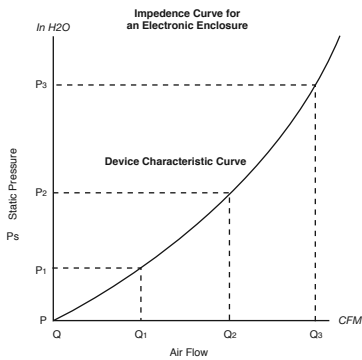
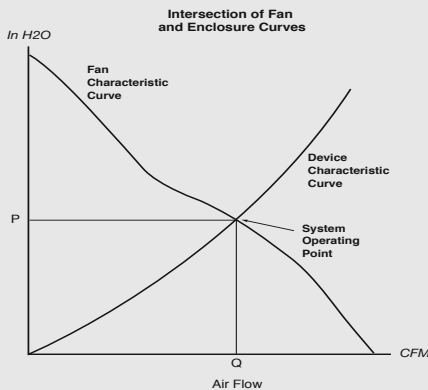
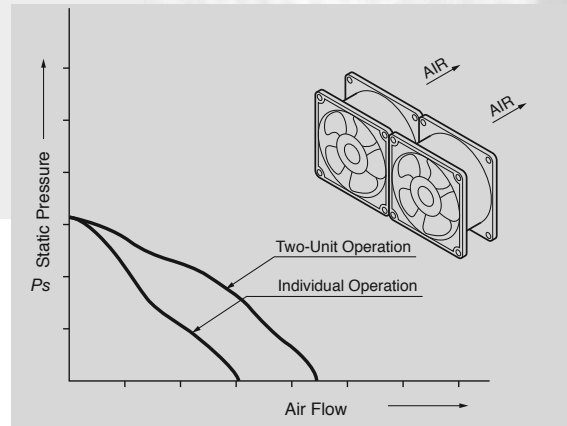

Chart 2.3



MULTIPLE FAN USE

The following figures show the performance characteristics for parallel and series operation of two identical fans.



Parallel Operation

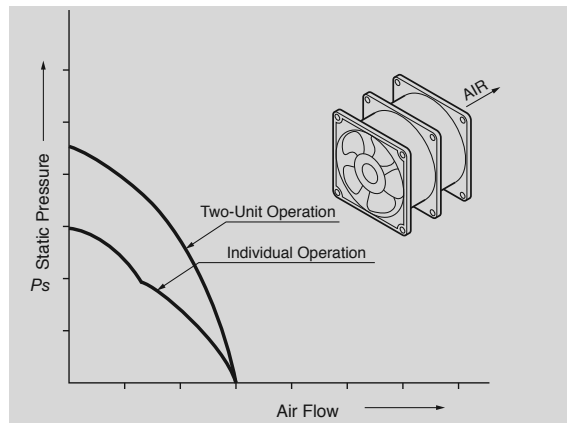

Series Operation

An additional fan in parallel to the first increases airflow in a low static pressure situation. An additional fan in series increases the airflow in a high static-pressure enclosure.

AIRFLOW & PRESSURE MEASUREMENT

An AMCA Standard 210 double chamber is used to accurately measure air volume and static pressure.

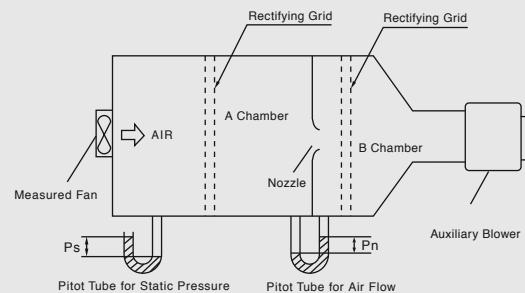



AIRFLOW & PRESSURE MEASUREMENT (continued)

Maximum Static Pressure: When the nozzle is closed, the pressure in chamber A will reach maximum.

Maximum Airflow: When opening the nozzle and absorbing the air using the auxiliary blower to make the static pressure zero ($P_s = 0$), the differential pressure (P_n) between A chamber and B chamber will reach maximum. The airflow obtained by applying the differential pressure (P_n) to the above equation can be called the maximum airflow.

Note: **Fan performance is calculated using the data obtained from this equipment according to the following formula:**

The Equation: Airflow

$$Q = 60 \cdot C \cdot \frac{\pi}{4} \cdot D^2 \sqrt{2g/r \cdot 0.10197 P_n} \quad (\text{m}^3/\text{min})$$

C: Coefficient of nozzle air

D: Diameter of nozzle (m)

r: Air density

$$\left(1.293 \times \frac{273}{273+t} \times \frac{P}{1013.25} \right) \quad (\text{kg}/\text{m}^3)$$

t: Temperature ($^{\circ}\text{C}$)

P: Air pressure (hPa)

P_n : differential pressure of air flow (Pa)

g: $9.8\text{m}/\text{s}^2$

ACOUSTIC NOISE MEASUREMENT

Noise measurements are performed in an Anechoic Chamber with less than 16 dBA background noise in compliance with JIS C 9603 standards.

DC Fan 1 m from inlet side

AC Fan 1 m from the side

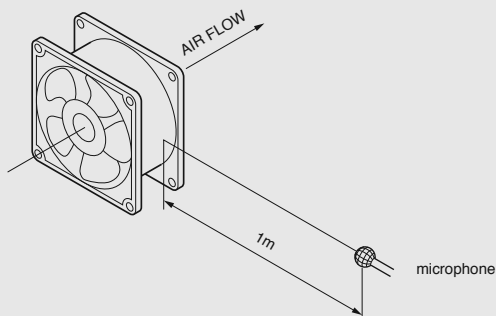

FAN SENSORS

Three types of DC fan sensors are available for NMB fans:

Locked Rotor Signal – outputs the status of the fan motor and is ideal for detecting if the fan motor is rotating or stopped.

Tachometer Signal – set to produce two cycles of rectangular waveform as the fan motor makes one rotation and is ideal for detecting speed.

Life Signal – detects a reduction in fan speed at a specified RPM level.

Locked Rotor Alarm Signal:

Output Circuit: Open Collector

Specifications:

Vce max: +30V

Vce max: +15V(1004KL, 1404KL, 1204KL, 1604KL, 1606KL, 1608KL, 2004KL, 2106KL, 2406KL, BM4515, BM5115, BM5125, BM6015)

Ic max: 5mA (Vce(sat)max=0.4V)

Alarm Signal Circuit

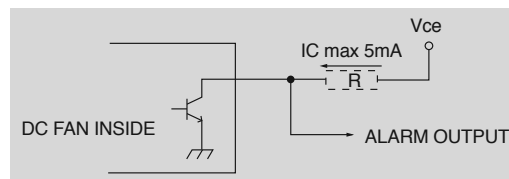

Alarm Signal Output: White, +:Red, -:Black

TTL output is an available option.

Alarm Signal Circuit

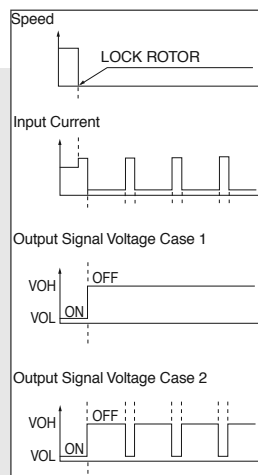
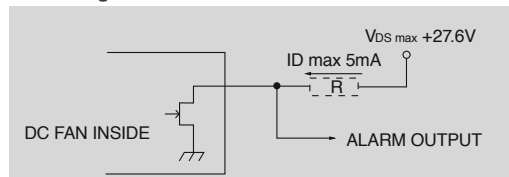

Output Waveform:

At Rated Voltag, the output signal may correspond to either Case 1 or Case 2.

Your design should provide for both waveforms.



Tachometer Signal

Output Waveform: At Rated Voltage

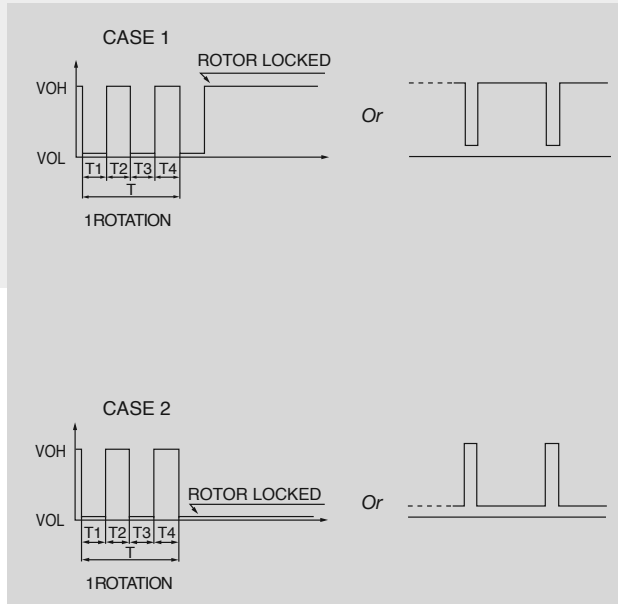

$T = T1 + T2 + T3 + T4 = 1 \text{ Rotation}$, $T1 = T2 = T3 = T4 = 60/4 \text{ m m: Rotation Speed min}^{-1}$

The output signal may correspond to Case 1 or Case 2. Your design should provide for both waveforms.

Life Signal

Output Waveform: At Rated Voltage

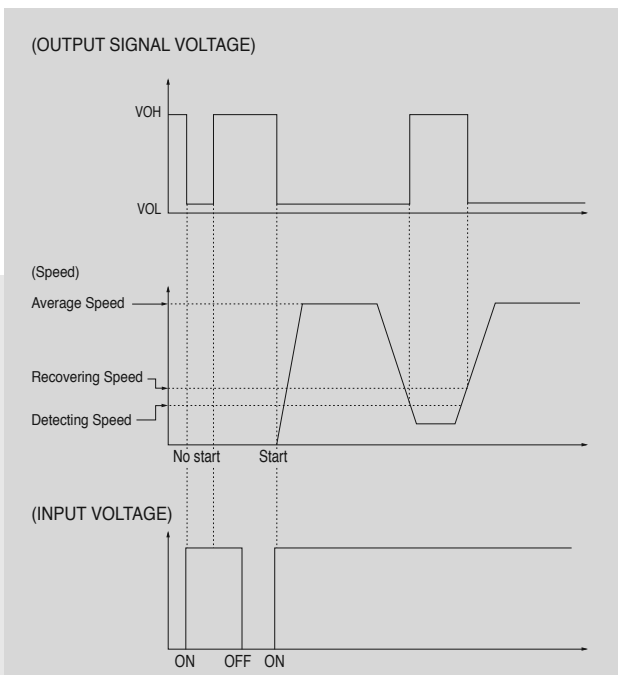

SPEED CONTROL

DC fan speed can be controlled in order to optimize cooling, reduce noise and decrease system power draw. There are various methods of controlling fan speed.

2-speed DC fan motor

NMB's custom 2 speed fans are available with high and low speeds specified by the customer. The low end operating speed is fixed in order to reduce noise and lower power consumption.

Below is an example of an External connection for a 2-speed DC fan motor.

Control by relay contact

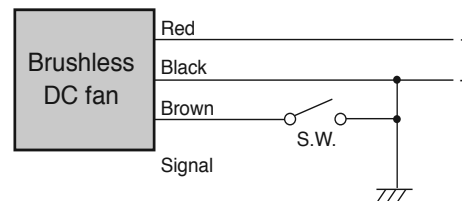

Control by transistor

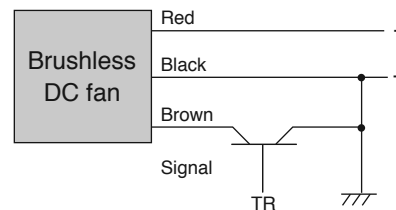

Switch-over of fan speed

S.W. OFF: LOW SPEED, ON: HI SPEED

Temperature Detecting Variable Speed DC Fan

The RPM may be automatically controlled and synchronized with temperature variation by installing a thermistor.

Varying the control voltage (0 to 6V) enables speed variation between the signal wire and ground.

Example of connection diagram:

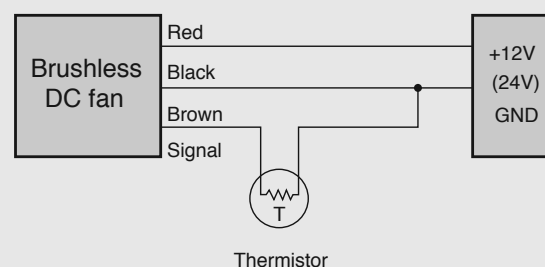



PWM Control DC Fan

In PWM speed control, a fixed frequency square wave is applied to the speed control leadwire of the fan. The ratio of on time vs. off time (duty cycle) is directly proportional to the speed of the fan.

Example:

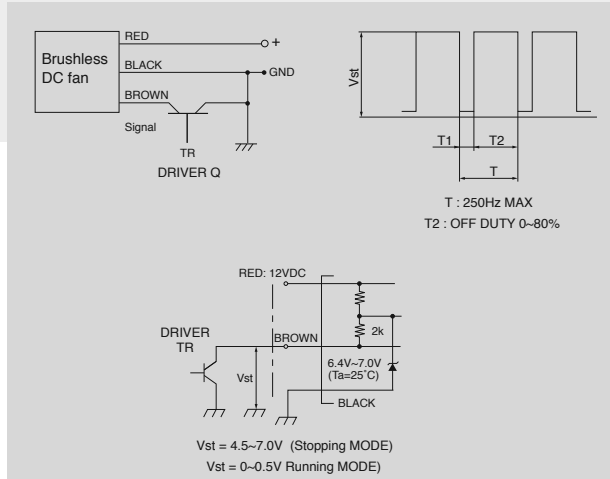

Correct Signal Connection

Correct signal connection is important to prevent damage to the internal fan IC. Connection should be design as shown below:

Signal Output



RPM Control Signal

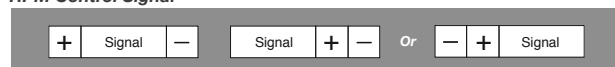

RPM Control Signal & Sensor Signal Output

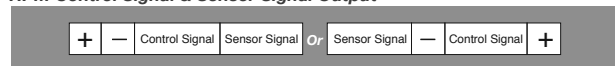

FAN LAWS

There are various laws useful in determining different fan performance parameters. We have selected a few of these that can be useful in calculating airflow (CFM), pressure (inches H₂O), power consumption (Watts), and noise (dBA), when operating at differing speeds (RPM).

Only fans of the same physical dimensions, same motor and impeller should be used for comparative analysis. The variables below are used in the formulas that follow:

Where:

- Speed _k = Known Speed
- Speed _n = The new speed we are using for calculation
- Airflow _k = Known airflow at Speed _k
- Airflow _n = New airflow calculated at new speed
- Pressure _k = Known Pressure at Speed _k
- Pressure _n = New pressure calculated at new speed
- Power _k = Known Power at Speed _k
- Power _n = New Power calculated at new speed
- Noise _k = Known Noise at Speed _k
- Noise _n = New Noise calculated at new speed

Calculating Airflow at different speeds:

$$\text{Airflow}_n = \text{Airflow}_k \left(\frac{\text{Speed}_n}{\text{Speed}_k} \right)$$

Calculating Pressure at different speeds:

$$\text{Airflow}_n = \text{Airflow}_k \left(\frac{\text{Speed}_n}{\text{Speed}_k} \right)^2$$

Calculating Power Draw at different speeds:

$$\text{Power}_n = \text{Power}_k \left(\frac{\text{Speed}_n}{\text{Speed}_k} \right)^3$$

Calculating Noise at different speeds:

$$\text{Noise}_n = \text{Noise}_k + 50 \log \left(\frac{\text{Speed}_n}{\text{Speed}_k} \right)$$

Airflow Calculation Example:

If a fan provides 210 CFM of airflow at 3000 RPM. What airflow (CFM) would be expected if the speed (RPM) is increased to 3500 RPM?

- Speed _k = 3000 RPM
- Airflow _k = 210 FM
- Speed _n = 3500 RPM

$$\text{Airflow}_n = \text{Airflow}_k \left(\frac{\text{Speed}_n}{\text{Speed}_k} \right)$$

$$\text{Airflow}_n = 245 \text{ CFM}$$



Pressure Calculation Example:

In the example above the fan provides 0.1 inches of H₂O Pressure at the system operating point. What pressure would be expected if the fan speed were increased to 3500 RPM?

Speed _ k = 3000 RPM
 Speed _ n = 3500 RPM
 Pressure _ k = 0.1 in H₂O

$$\text{Pressure}_n = \text{Pressure}_k \left(\frac{\text{Speed}_n}{\text{Speed}_k} \right)^2$$

Pressure _ k = 0.136 in H₂O

Power Calculation Example:

The fan in question draws 22 Watts at 3000 RPM. What power draw would be expected if the fan speed were increased to 3500 RPM?

Speed _ k = 3000 RPM
 Speed _ n = 3500 RPM
 Power _ k = 22 watt

$$\text{Power}_n = \text{Power}_k \left(\frac{\text{Speed}_n}{\text{Speed}_k} \right)^3$$

Power _ n = 34.935 watt

Noise Calculation Example:

The fan in question generates 58 dBA of noise measured 1 meter from the inlet side of the fan. What would the increase in noise be if the the speed were increased form 3000 RPM to 3500 RPM?

Speed _ k = 3000 RPM
 Speed _ n = 3500 RPM
 Noise _ k = 58 dBA

$$\text{Noise}_n = \text{Noise}_k + 50 \cdot \log \left(\frac{\text{Speed}_n}{\text{Speed}_k} \right)$$

Noise _ n = 61.347 dBA

UNITS OF MEASURE AND CONVERSIONS

Fan airflow, static pressure, temperature, and dimensions are often referred to in a variety of unit measures. Below are the measures and methods of conversion.

Airflow

CFM	m ³ /min	m ³ /hr	1/sec
1	0.028	1.7	0.47
35.3	1	6.	16.7
0.59	0.017	1	0.28
0.16	0.06	3.6	1

To convert CFM to m³/hr, multiply by 1.7

Static Pressure

in H ₂ O	mm H ₂ O	Pa
1	25.4	249
0.039	1	9.81
0.004	0.1	1

To convert PA to H₂O, multiply by 0.004

Temperature

Degree F = 9/5 C + 32
 Degree K = C + 273/15

Linear Dimensions

1mm = 0.0394" ~ 0.04
 1" = 25.4mm = 2.54 cm
 1U = 44.4 mm = 1.75"

NMB TECHNICAL SUPPORT

NMB offers a full range of application and design support services, including thermal modeling and flow analysis. For assistance with any technical issue, please contact the NMB Fan Team through our web site at www.nmbtc.com or e-mail us at fans@nmbtc.com.



FAN LIFE AND RELIABILITY

Fan Life Testing

Life expectancy of a cooling fan is a critical element in thermal design. NMB uses parametric failure modes during life testing to calculate for life expectancy. Speed (RPM) and Current (mA) failures include both “hard failures” (where the fan is non-functional) and “parametric failures”. These parametric failures are defined as 15% decrease in RPM and an increase in mA of 15%.

Including parametric failure modes leads to a more conservative L-10 and MTTF reporting standard than those methods that measure life performance using only hard failures.

The benefit to the customer is a fan that sets the quality and reliability standard for the cooling industry.

NMB evaluates fan life and reliability during the design phase using accelerated life testing in conjunction with ORT (Ongoing Reliability Testing). Accelerated life testing is used to compress the amount of time required to conduct life testing. Development testing occurs early in the product design, prior to product release. It is vital to characterize the reliability of the product in the initial stages of design to allow for improvements and to meet the reliability specifications prior to release to manufacturing.

Once the design has been through design verification testing and is turned over to manufacturing, ORT is conducted. For some models, ORT evaluation has continued beyond 10 years. The value of ORT is a continued refinement of the accuracy of the accelerated life testing and constant review of the design of the fan. This continued process improvement allows for ongoing evaluation and increase in fan life and reliability.

Under accelerated life testing NMB fans are tested at extreme environmental conditions, with temperature stress factors above standard operating levels. In order to gather meaningful data within a reasonable time frame, the stress factors must be accelerated to simulate different operating environments. High temperature stress is the most common stress factor used for these purposes.

Proper understanding of accelerating stresses and design limits are necessary to implement a meaningful accelerated reliability test. NMB uses the Arrhenius model for determining acceleration factors (AF) during life testing. This is the most commonly used model in accelerated life testing where thermal stress is the primary factor affecting life.

Life test data gathered from different types of fans and blowers lends to highly accurate statistical analysis. This data can produce very detailed information about the behavior of the product for reliability and prediction of fan performance in the field. The Weibull Distribution is a typical method employed by NMB for statistical analysis. An explanation of this calculation model is shown below.

Arrhenius Weibull Model:

Life Stress Relation: Arrhenius

The Arrhenius life-stress relationship is given by:

$$\eta = L(V) = C \cdot e^{\frac{\beta}{V}}$$

Where:

- L represents a quantifiable life measure, which is the scale parameter or characteristic life of the Weibull Distribution.
- V represents the stress level (formulated for temperature and temperature values in absolute units, i.e. degrees Kelvin or degrees Rankine)
- C is one of the model parameters to be determined ($C > 0$).
- B is another model parameter to be determined

Mean Life or MTTF

The mean, \bar{T} , also called MTTF or Mean Time To Failure, of the Arrhenius-Weibull relationship is given by:

$$\bar{T} = C \cdot \frac{B}{eV} \cdot T \left(\frac{1}{\beta} + 1 \right)$$

Reliable Life

The Arrhenius Weibull Distribution model predicts the length of time at which a defined percentage of a product population will still be operating without failing to meet pre-set criteria. For cooling fans, this is normally characterized as L10 life expectancy, or the time at which 10% of a population will have failed and 90% of a population will continue to operate within specifications.

For the Arrhenius-Weibull relationship, the reliable life, T_R , of a unit for a specified reliability and starting the mission at age zero is given by:

$$T_R = C \cdot \frac{B}{eV} \{ -\ln [R(T_R, V)] \} \frac{1}{\beta}$$

This is the life for which the unit will function successfully with a reliability of $R(T_R)$. If $R(T_R) = 0.90$ then $T_R = 90\%$ reliability or 10% unreliability (L10) or the life by which 90% of the units will survive.



NMB uses parametric failure modes, or the condition at which a performance parameter fails to meet pre-set criteria, to record failures during accelerated life testing. This produces a more accurate prediction of field reliability than methods which use only non-operating failure modes to record failures.

Example: Life Experiment Data Using Arrhenius Weibull

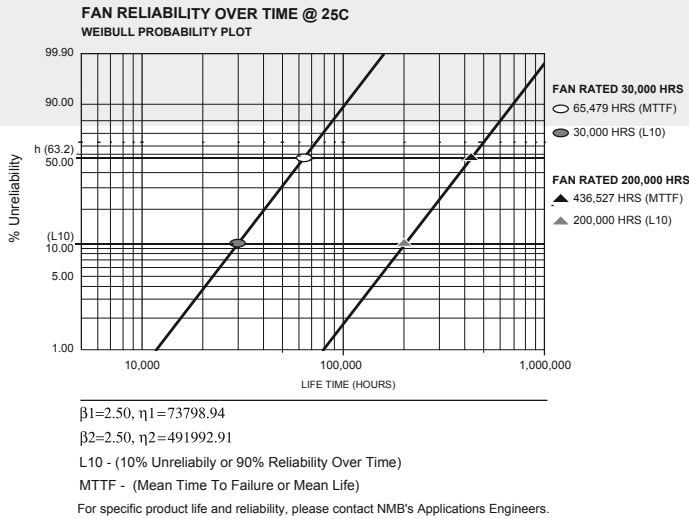

Product L10 life expectancy for NMB fans ranges from 30,000 hours to 200,000 hours of continuous operation at room temperature depending on fan speed, frame size, design structure, size of ball bearings and the type of ball bearings used. NMB, a world leader in miniature precision ball bearings design and manufacturing, uses high quality, long life bearings produced in house to ensure extended fan life.

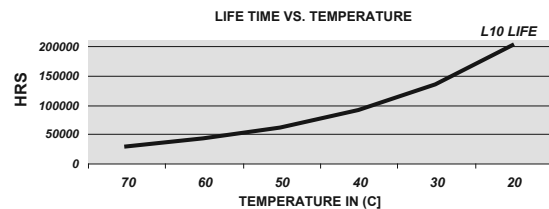
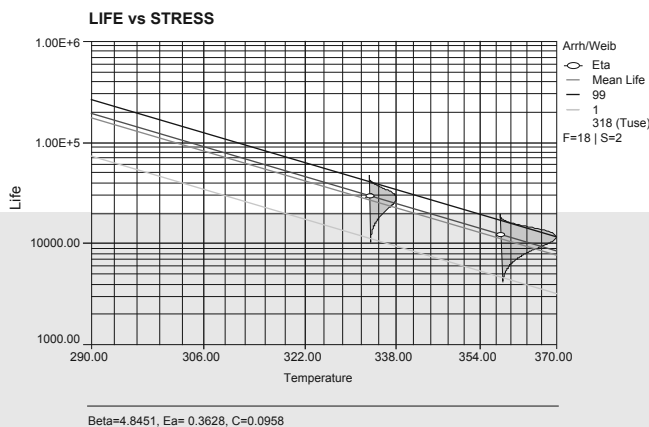



Fan Guards

- Designed to insure safety
- Plating bright nickel chrome, black electro deposit available
- Plating thickness of .0005 min.
- Weld joints withstand 230 lbs. separation force
- Wire base C1010 steel

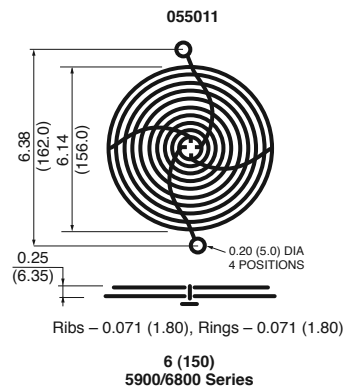
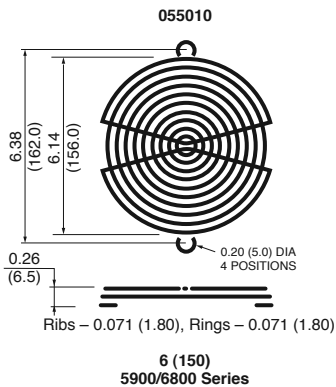
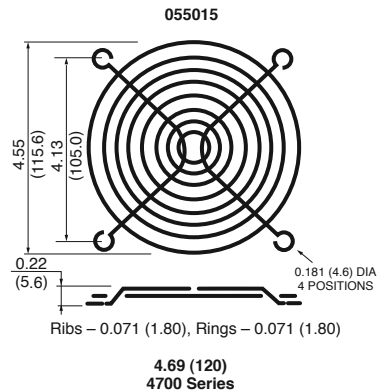
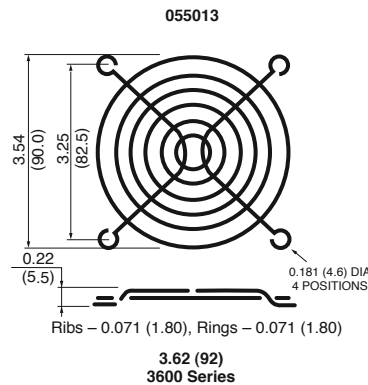
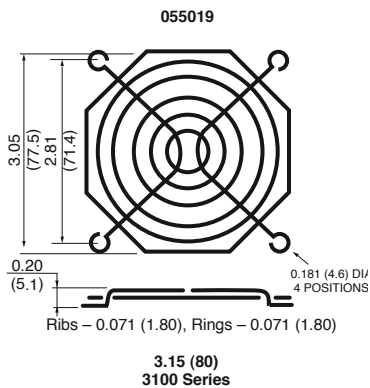
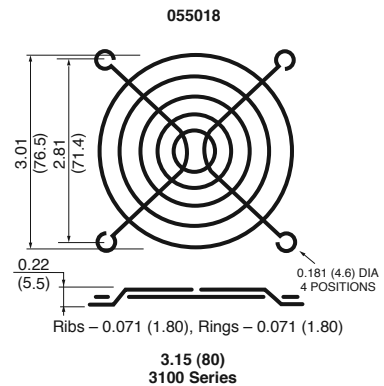
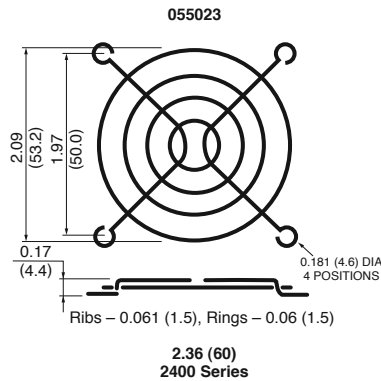
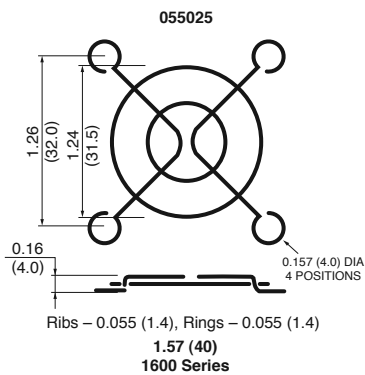

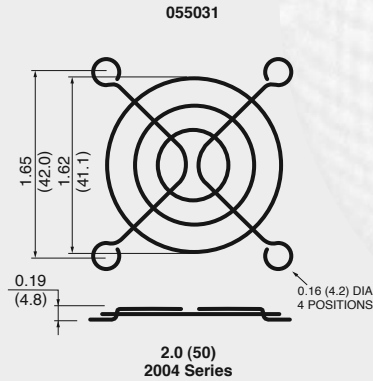
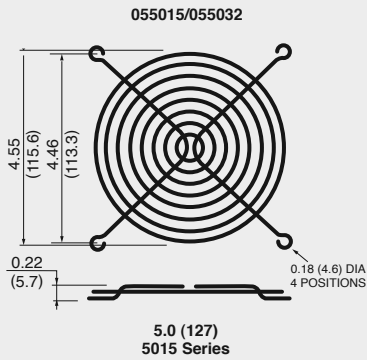

Fan Mode	055010	055011	055013	055015	055018	055019	055023	055025	055031	055032	512011	512020	512023	432000	432002	432021
1004KL																
1204KL																
1404KL																
1604KL																
1606KL																
1608KL																
2004KL																
2106KL																
2406KL																
2408NL																
2410ML																
2410ML Vented																
3108NL																
3110KL																
3112KL																
3610KL																
3610KL Vented																
3612KL																
3615KL																
4710KL																
4712KL																
4715KL																
4715SL																
5015KL																
5020KL																
5910PL																
5920PL																
6820PL																
2412PS																
3110PS																
3115FS																
3115PS																
3610PS																
4710PS																
4715FS																
4715MS																
5915PC																

***NMB Fan Warranty Policy***

NMB warranties our fans to be free from defects in material and workmanship for a period of one (1) year. In order to accommodate transportation and installation we extend this warranty to 15 months from the date of manufacture.

This warranty applies to fans and blowers which are used within the design parameters and when used in an approved application. If there are any questions regarding proper application please contact your NMB representative and an applications engineer can review the customer's operational requirements.

Warranty Limitations and Liability

In the event of an operational failure of an NMB fan or blower, which was used in a manner specifically approved by NMB, NMB will at its option, repair or replace the defective fan or blower with an identical or functionally equivalent product.

In no case will NMB's liability exceed the purchase price of the defective product.

Errors

All information, data and dimension tables in this catalog have been carefully compiled and thoroughly checked. However, no responsibility for possible errors or omissions can be assumed.

Changes

The company reserves the right to change specifications and other information included in this catalog without notice.



Additional Products from NMB

Mechanical Assemblies

NMB's Precision Mechanical Assemblies are bearing assemblies designed for a wide range of applications, including high-accuracy head positioning pivot assemblies, encoder assemblies for robotics, CAD/CAM systems and factory automation.



Many of these mechanical assemblies are found in office automation, including integral bearings for use in rigid disk drive spindles, and as part of printers, fax machines and copiers. Our Precision Mechanical Assemblies are custom made - NMB engineers work with you to design the best solution for your project.

For more information on our mechanical assembly products, e-mail us at: assemblies@nmbtc.com

Small Motors

NMB offers a wide variety of small motors, including hybrid step motors in standard NEMA sizes 14 to 23, as well as molded type flange (MTF) step motors available in NEMA sizes 10 to 17.



A new line of gear motors available in range of ratios from 3:1 to 2000:1. Gearbox offerings are available for all hybrid and PM motors. The NMB family of small motors also includes hybrid linear motors, brush DC motors and a range of brushless DC motors from 0.1 W to 500 W. Our newest small step motor line is found in the consumer electronic industry, from digital cameras, mobile, and audio visual equipment to measuring and game equipment.

For more information on our motor products, e-mail us at motors@nmbtc.com

Bearings

Our miniature bearings range in sizes from .1181 to 1.000 inch O.D. (3mm to 26mm), and are available in inch and metric sizes. Stainless steel or chrome



steel bearings are available with crown or ribbon type metallic cages, as well as plastic crown type cages. NMB bearings are found in medical equipment, advanced automotive applications and household electrical appliances such as air conditioners, vacuum cleaners, VCRs and video cameras, and in motors for electronic controls systems, among others.

Keyboards

NMB produces more than 1.5 million keyboards each month to meet the needs of leading PC OEM's. The keyboard division offers a wide range of



standard and custom product. We are experts in desktop, notebook, wireless, security and accessory keyboard designs. Capabilities include industrial design, keyswitches, protocols, firmware development and wireless technology such as Radio Frequency and Infrared Communications.

For more information on our keyboard products, e-mail us at keyboards@nmbtc.com

Audio

PC and consumer industries turn to NMB for speaker drivers as well as total audio solutions. NMB is a leading speaker driver supplier to elite audio brands found in Hi-Fi, home entertainment, and automotive sound systems. In addition, PC industry leaders choose NMB to provide high quality, cost-effective multimedia solutions.



For more information on our audio products, e-mail us at speakers@nmbtc.com



Personal Service... Global Reach

NMB Technologies Corporation Sales Offices

North America

Corporate Headquarters

9730 Independence Avenue
Chatsworth, CA 91311
Ph. 818-341-3355, Fax 818-341-8207

NMB Automotive Division & Technical Center

28700 Beck Road
Wixom, MI 48393
Ph. 248-926-0026, Fax 248-926-0025

International Sales Offices

Shanghai, China
Bangalore, India
Bracknell, England
Baillet en France, France
Langen, Germany
Kowloon, Hong Kong
Milan, Italy
Tokyo, Japan
Kuala Lumpur, Malaysia
Manila, Philippines
Singapore
Seoul, South Korea
Taipei, Taiwan
Bangkok, Thailand
Hanoi, Vietnam

Represented by:

E-mail: info@nmbtc.com
Web site: www.nmbtc.com

ISO 14001 • ISO 9001:2000 • TS 16949 • OHSAS 18001