

4.5 mm Square SMD Light Touch Switches

Type: **EVQPQ**



■ Features

- External dimensions: 4.5 mm×4.5 mm, Height 0.55 mm
- Lightweight: 20 mg (1/2 compared with conventional type)

■ Recommended Applications

- Operation switches for portable electronic equipment (Camcorders, Portable audio players, etc.)

■ Explanation of Part Numbers

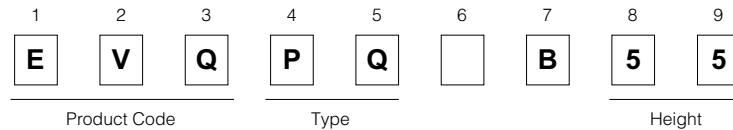

■ Specifications

Type		Snap action/Push-on type SPST
Electrical	Rating	10 μ A 2 Vdc to 20 mA 15 Vdc (Resistive load)
	Contact Resistance	100 m Ω max.
	Insulation Resistance	50 M Ω min. (at 100 Vdc)
	Dielectric Withstanding Voltage	250 Vac for 1 minute
	Bouncing	3 ms max. (ON) 10 ms max. (OFF)
Mechanical	Operating Force	1.6 N \pm 0.5 N 2.4 N \pm 0.6 N
	Travel	0.2 mm \pm 0.1 mm
Endurance	Operating Life	200000 cycles min. (1.6 N), 50000 cycles min. (2.4 N)
Operating Temperature		-20 $^{\circ}$ C to +70 $^{\circ}$ C
Storage Temperature		-40 $^{\circ}$ C to +85 $^{\circ}$ C (Bulk) -20 $^{\circ}$ C to +60 $^{\circ}$ C (Taping)
Minimum Quantity/Packing Unit		10000 pcs. Embossed Taping (Reel Pack)
Quantity/Carton		50000 pcs.

Note: Non washable

Design and specifications are each subject to change without notice. Ask factory for the current technical specifications before purchase and/or use. Should a safety concern arise regarding this product, please be sure to contact us immediately.

00 Sep. 2010

■ Dimensions in mm (not to scale)

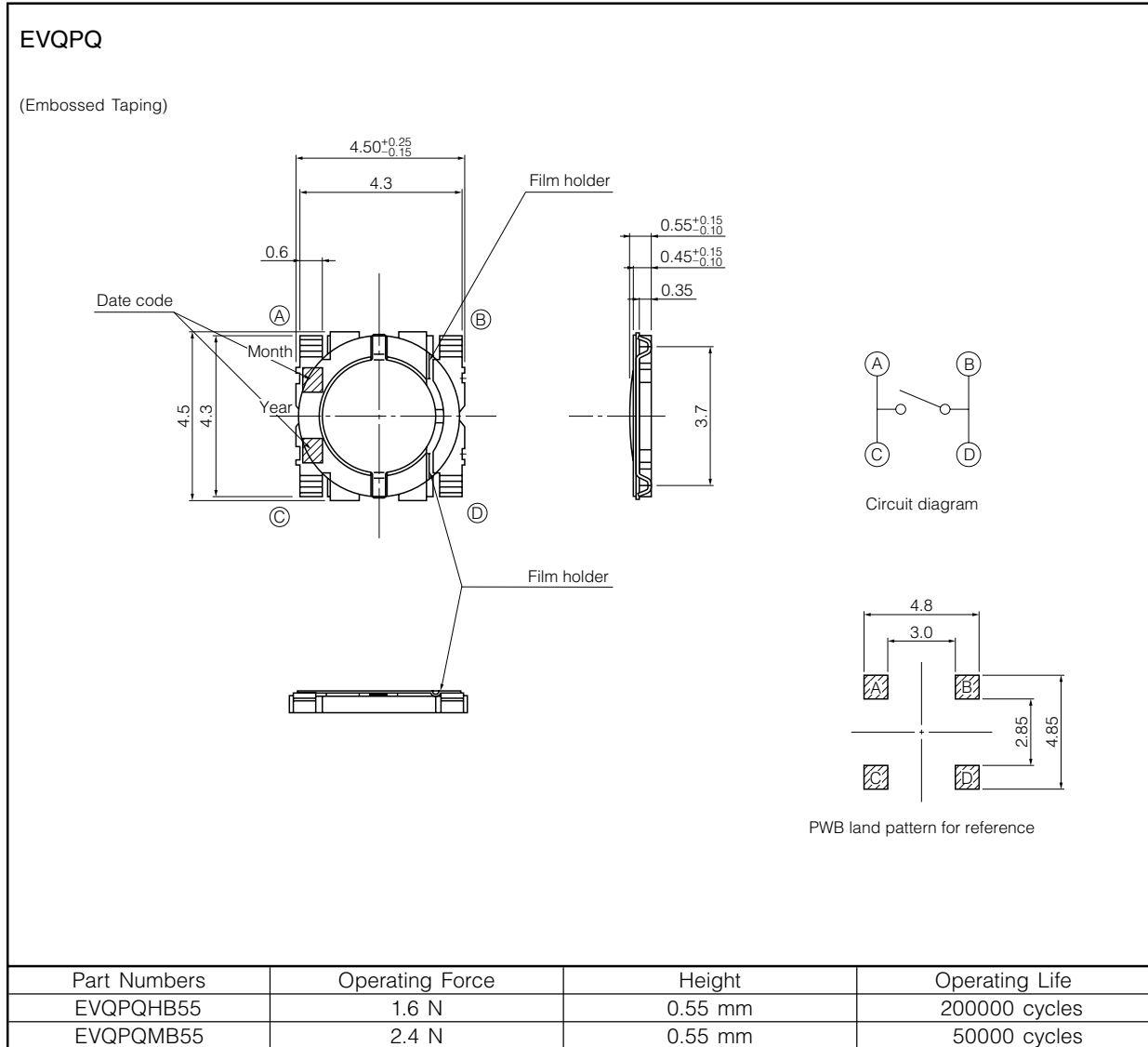

■ Before using this product

- If the inclination of the actuator is widened by using soft materials, such as rubber, for the setting side of the operation section (connecting area between button and actuator), it may cause functional problems.

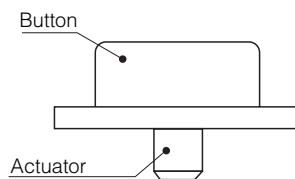

Recommended Reflow Soldering Conditions

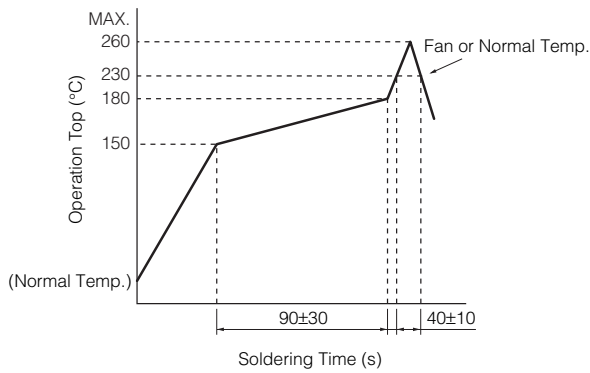

Embossed Carrier Taping

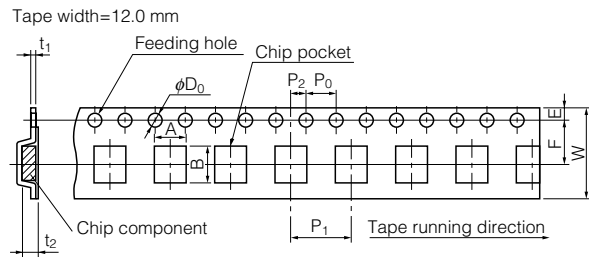

Unit: mm

Part No.	Height	A	B	W	F	E	P ₁	P ₂	P ₀	D ₀ Dia.	t ₁	t ₂
EVQPQ	0.55	5.0 ^{+0.30} _{-0.25}	4.6 ^{+0.3} ₋₀	12.0±0.1	5.5±0.1	1.75±0.10	8.0±0.1	2.0±0.1	4.0±0.1	1.5 ^{+0.1} ₋₀	0.30±0.05	0.65 ^{+0.2} _{-0.1}

Standard Reel Dimensions in mm (not to scale)

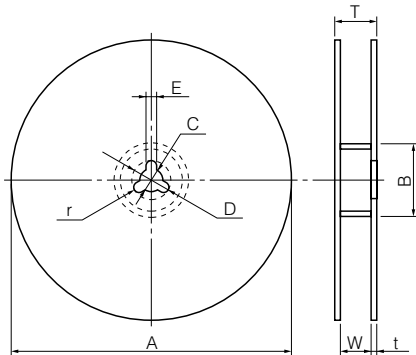

Item	A	B	C	D	E
Rate (mm)	φ370.0±2.0	φ50.0 min.	φ13.0±0.5	φ21.0±1.0	2.0±0.5

Item	W	T	t	r
Rate (mm)	14.0±1.5	—	1.0 to 3.0	1.0±0.5

Recommended Shape of Test Pole

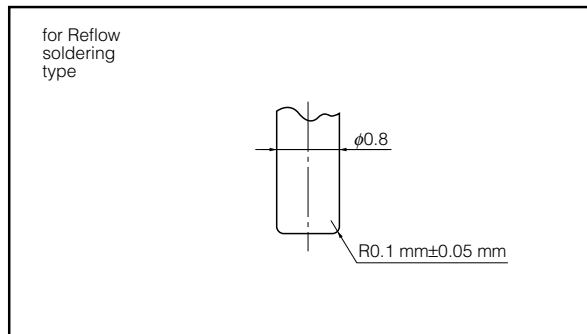

Recommended Operating Conditions

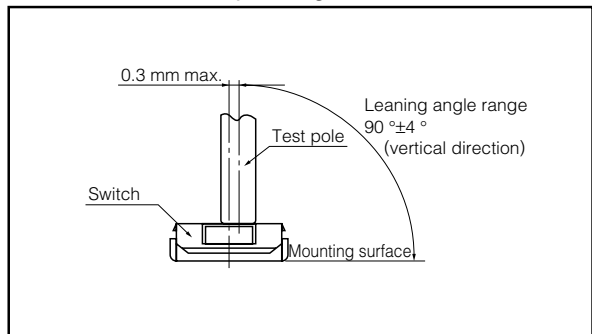

Design and specifications are each subject to change without notice. Ask factory for the current technical specifications before purchase and/or use. Should a safety concern arise regarding this product, please be sure to contact us immediately.

00 Sep. 2010