

Flavus GSM Snap-In Antenna

Part No. B5812-xx

Product Specification

1 Features

- GSM/UMTS antenna supporting up to 5 frequency bands
- High efficiency
- Easy to integrate
- Supplied in trays for simple snap-in assembly

Flavus GSM supports the following communication standards:

GSM/GPRS/EDGE	CDMA2000 1xRTT/EV-DO/EV-DV	UMTS WCDMA/HSPA	Other Standards
GSM850 (E)GSM900 GSM1800 (DCS) GSM1900 (PCS)	Band Classes: 1,2,3,4,6,8,9,12,14,15	Bands I – VI Bands VIII – X	Korean PCS DECT TD-SCDMA AWS

2 Description

The antenna is intended for snap-in assembly and is supplied in three different clip lengths suitable for attaching to different thicknesses of PCB.

Flavus uses a ground plane in order to radiate efficiently, but the ground plane must not be present underneath the antenna itself.

The antenna is used in conjunction with a matching circuit that can be optimized for the specific frequency bands that are required. This product specification shows the performance of the antenna when optimized to cover the following five bands: GSM850/900/1800/1900 and WCDMA. If the antenna is used for fewer than 5 bands, higher efficiencies are possible.

3 Applications

- Mobile handsets
- Pico base stations
- Vehicle tracking
- Machine to machine communication
- Remote monitoring



4 Part numbers

Flavus GSM: B5812-01 (for PCB thickness of 0.8 mm)
 Flavus GSM: B5812-02 (for PCB thickness of 1.0 mm)
 Flavus GSM: B5812-04 (for PCB thickness of 1.6 mm)

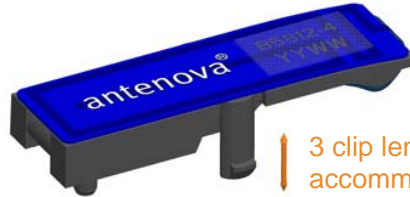

3 clip length versions to accommodate different PCB thicknesses

5 General data

Product name	Flavus GSM
Part Numbers: 0.8mm PCB 1.0mm PCB 1.6mm PCB	B5812-01 B5812-02 B5812-04
Frequency	824MHz-960MHz 1710MHz -2170MHz
Polarization	Linear
Operating temperature	-40 °C to +85 °C
Impedance with matching	50 Ω
Weight	0.6g
Antenna type	Snap - In
Dimensions: 1020B5812-01 1020B5812-02 1020B5812-04	27.3 x 9.6 x 4.05 [mm] 27.3 x 9.6 x 4.25 [mm] 27.3 x 9.6 x 4.85 [mm]

6 Electrical characteristics

	Typical performance	Conditions
Peak gain	3.2dBi	All data measured on Antenova's reference board, part number B5812-U1 Data given for the 824MHz-960MHz and 1710MHz-2170MHz frequency ranges
Average gain	-1.6dBi	
Average efficiency	70%	
Maximum Return Loss	-6dB	
Maximum VSWR	3:1	

7 Electrical performance

7-1 Return Loss

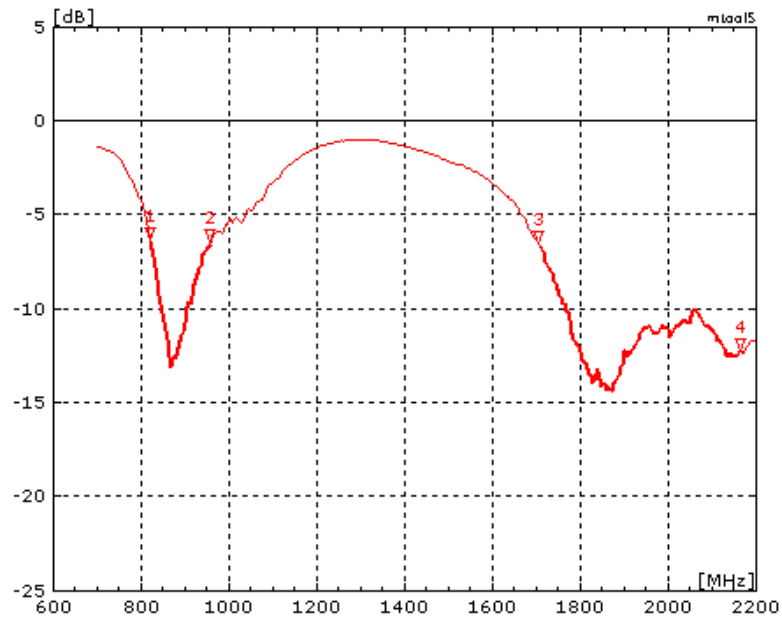

7-2 VSWR

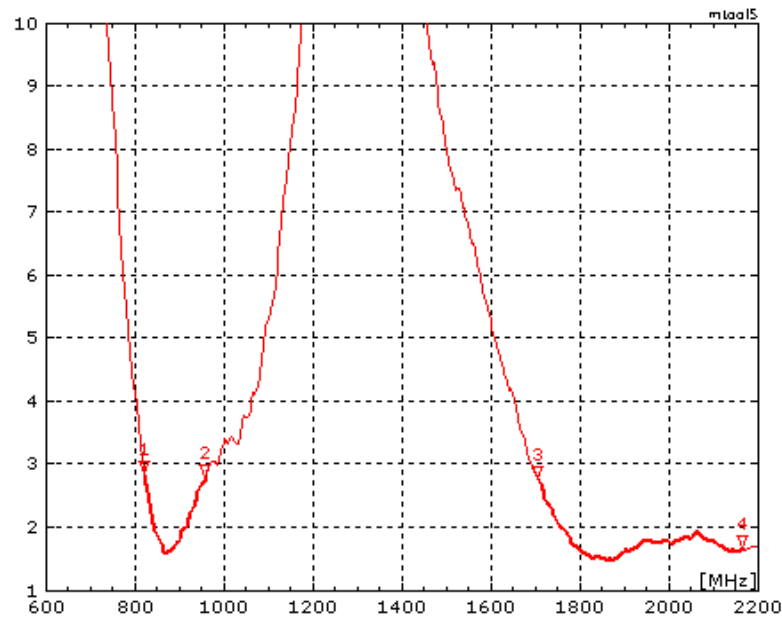

7-3 Antenna patterns – Low Frequency

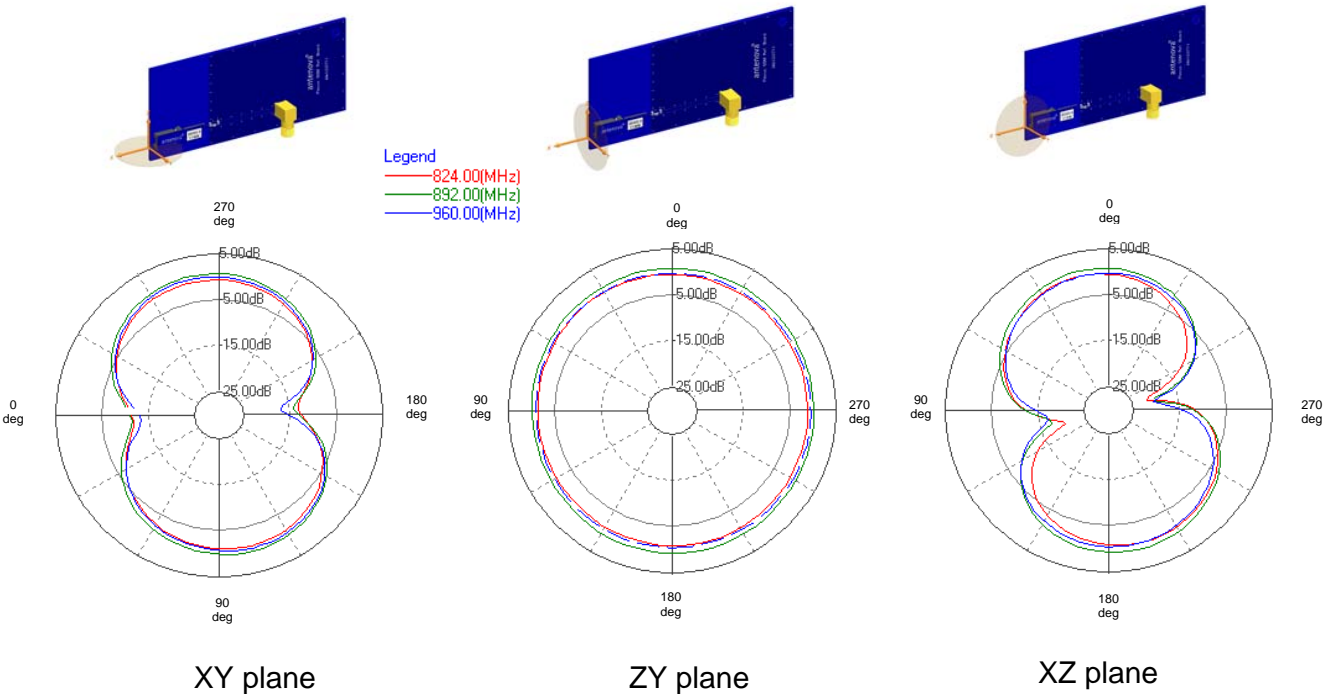
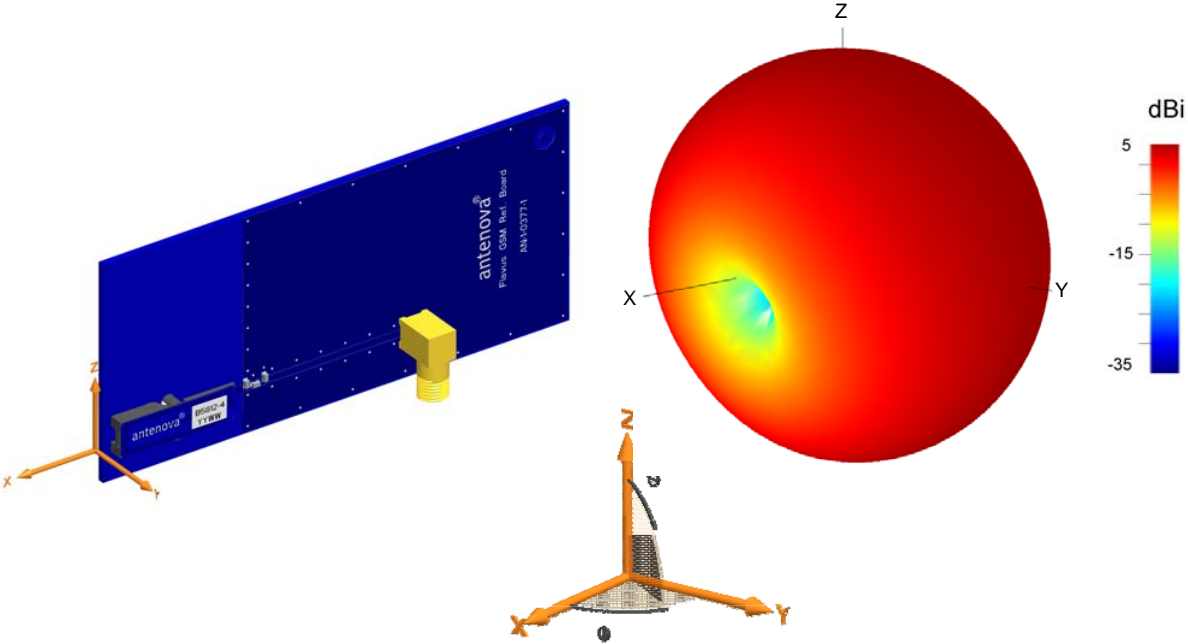

Patterns show combined polarisations measured on reference board B5812-U1. 3D Pattern measured at 892MHz

7-4 Antenna patterns – High Frequency

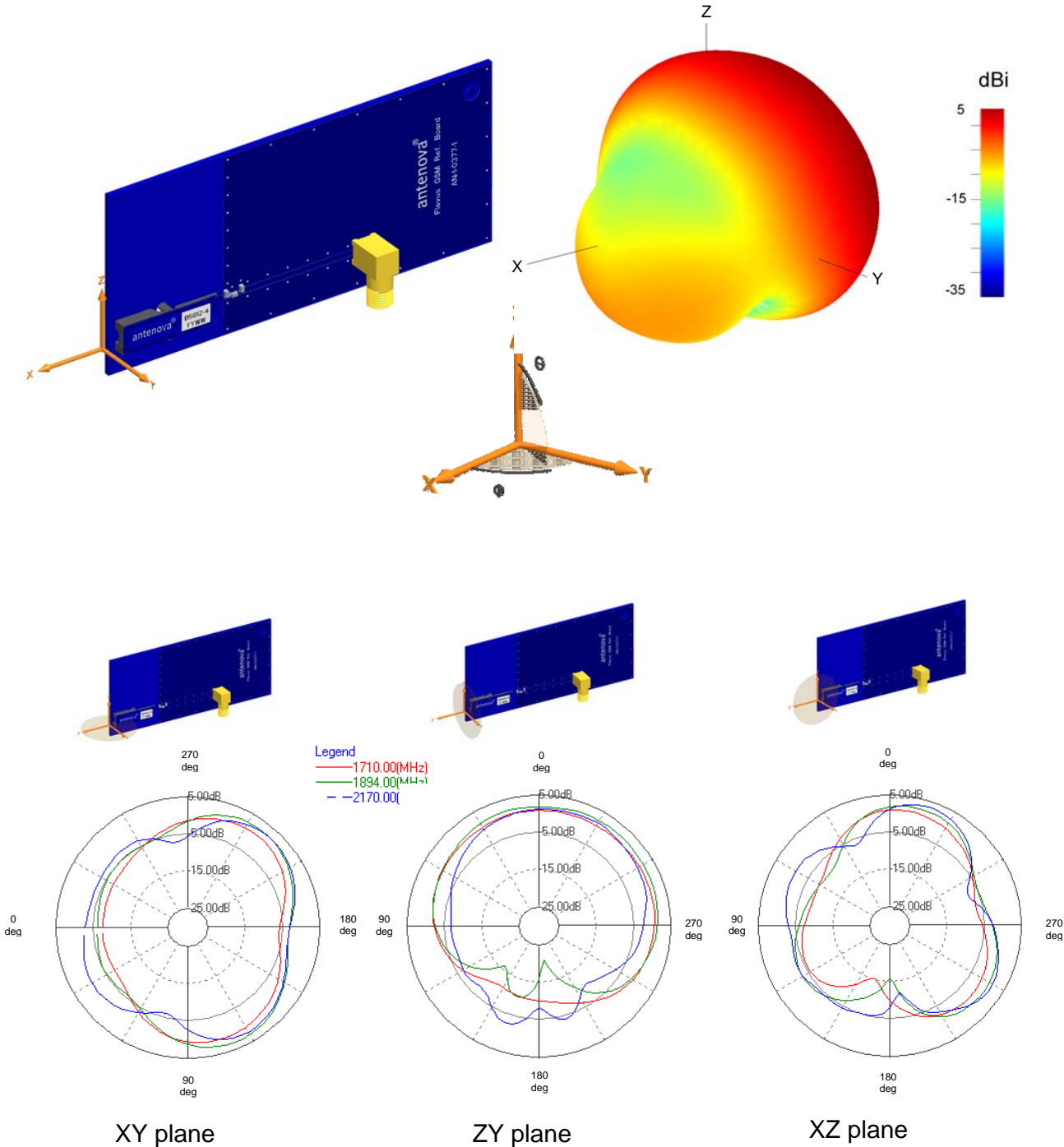

Patterns show combined polarisations measured on reference board B5812-U1. 3D Pattern measured at 1894MHz

Downloaded from Elcodis.com electronic components distributor

8 Antenna dimensions

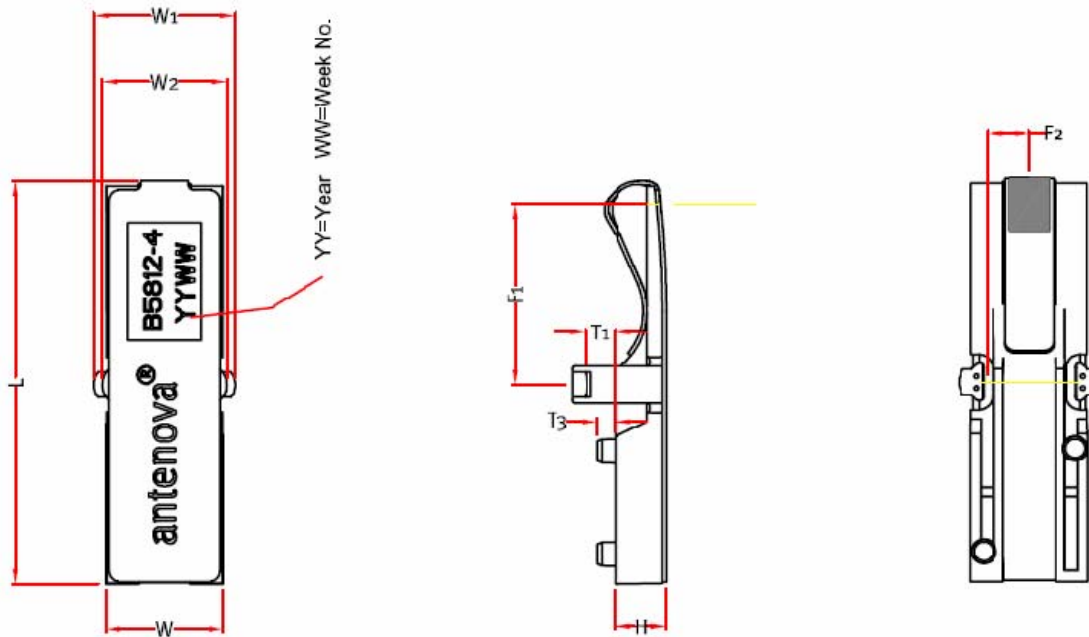

L	W	W1	W2	H	H1	F1	F2	T1*	T2	T3
Length	Width	Width	Width	Height	Height	Feed	Feed	PCB		
27.3+/-0.2	7.9+/-0.2	9.6+/-0.2	8.5 +/-0.2	3.45+/-0.1	3.85+/-0.1	11.85+/-0.2	2.8+/-0.1	0.8, 1.0, 1.6	1.35+/-0.2	1.3+/-0.1

* Flavus is available in three clip lengths to fit boards of 0.8mm, 1.0mm or 1.6mm thickness

9 Antenna footprint

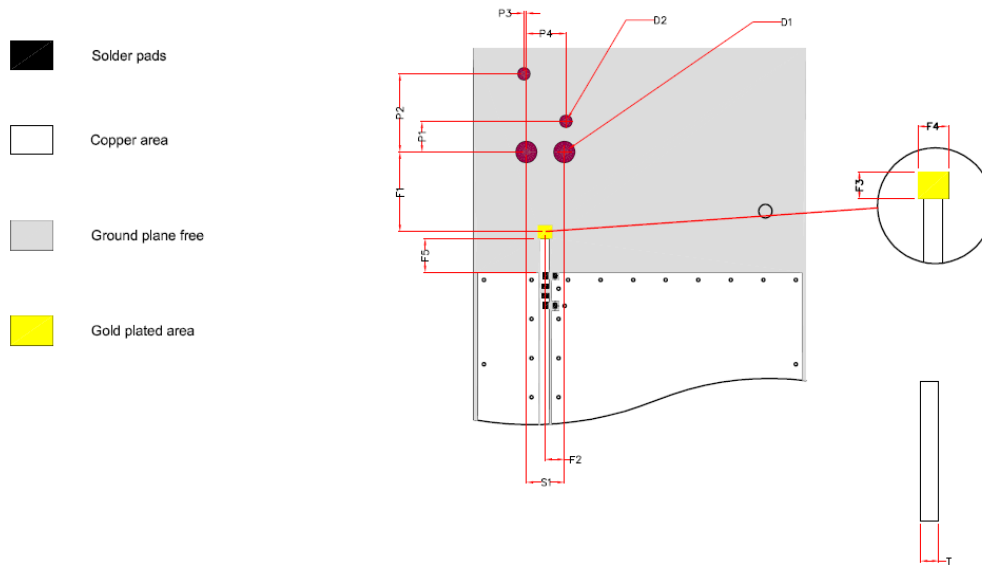

Flavus GSM (Part No: B5812-XX)

CAD files of the antenna footprint are available from Antenova on request. Please contact info@antenova.com for further details.

F1	F2	F3	F4	F5	S1	P1	P2	P3	P4	D1	D2	T*
Feed	Feed	Feed	Feed	Feed	Snap-In	Position	Position	Position	Position	Diameter	Diameter	PCB
11.85 +/-0.1	2.8 +/-0.1	2 +/-0.05	2.25 +/-0.05	5 +/-0.05	5.6 +/-0.1	4.5 +/-0.1	11.5 +/- 0.1	0.3 +/-0.1	5.9 +/-0.1	3.05 +/- 0.1	1.75 +/- 0.1	0.8, 1.0, 1.6

*PCB thickness dependent on Flavus model used.

10 Electrical interface

10-1 Transmission lines

The antenna should be connected using an RF transmission line.

- All transmission lines should be designed to have a characteristic impedance of 50 Ω
- The length of the transmission lines should be kept to a minimum
- Any other parts of the RF system like transceivers, power amplifiers, etc, should also be designed to have an impedance of 50 Ω

Once the material for the PCB has been chosen (PCB thickness and dielectric constant), a co-planar transmission line can easily be designed using any of the commercial software packages for transmission line design. For the chosen PCB thickness, copper thickness and substrate dielectric constant, the program will calculate the appropriate transmission line width and gaps on either side of the track so the characteristic impedance of the co-planar transmission line is 50 Ω .

10-2 Matching circuit

The antenna requires a matching circuit that must be optimized for each customer's product. The matching circuit will require up to three components and the following pad layout should be designed into the device so the correct circuit can be installed:

In addition to the matching circuit, a separate DC blocking capacitor will also be required between the radio and the antenna matching circuit.

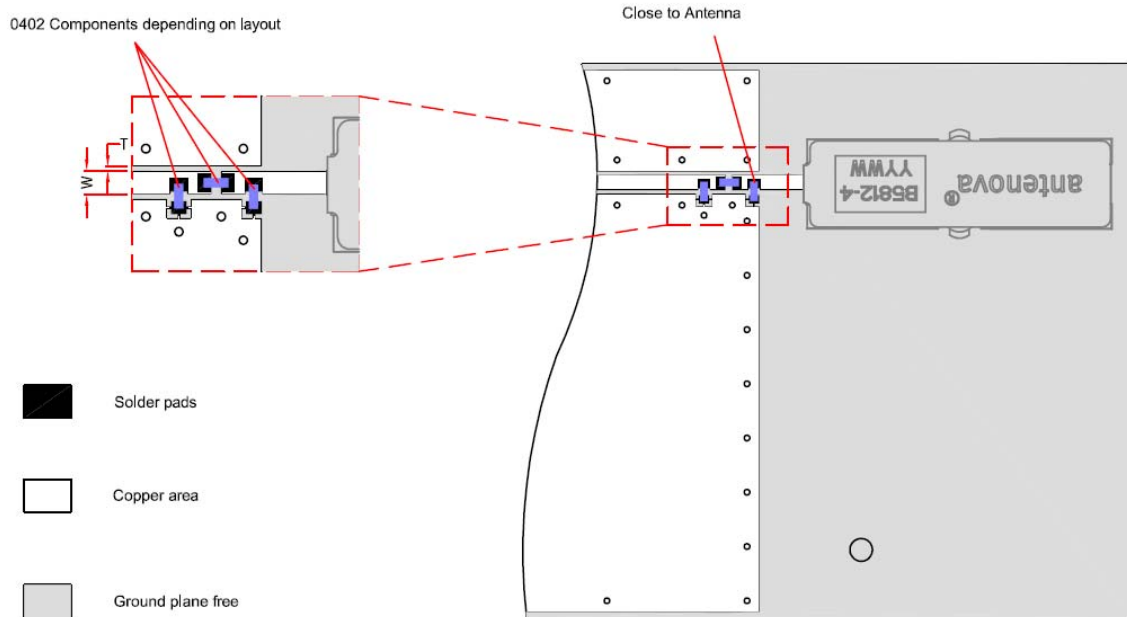

Dimensions "W" and "T" will depend on the material and thickness of the PCB and must be calculated to give a transmission line with a 50Ω characteristic impedance.

Note: The component values for the matching circuit will vary depending on the size of the PCB and surrounding components. The impedance of the antenna should be measured before selecting suitable matching components. AntenoVA offers a matching service on request. Contact info@antenoVA.com for further information.

10-3 Antenna placement

Flavus must be fitted to the device so that power from the antenna can radiate into free space. Antenna recommends fitting the antenna close to the corner of the PCB with few components or metal objects nearby. Ground can be placed at the side of the antenna closest to the feed, but the remaining space around the antenna, including directly above and below should be free from components or conducting objects.

Two recommended configurations are shown below, but other layouts are possible.

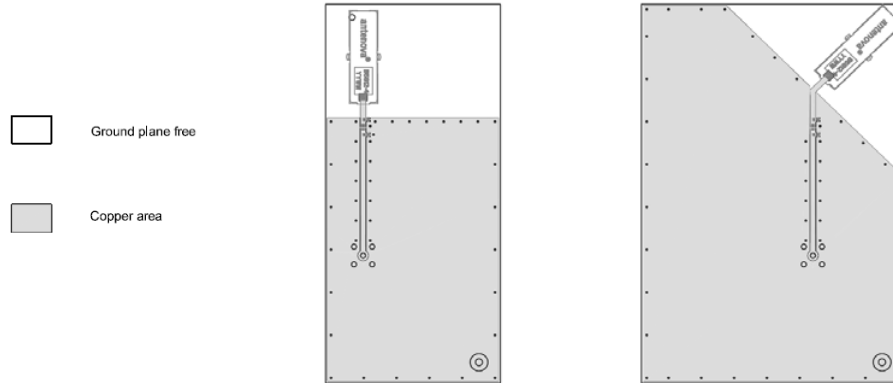

Recommended PCB layouts: antenna mounted straight (left) and at 45 degrees (right).

10-4 Space saving configuration

Where board space is limited, Flavus can be positioned closer to the main PCB ground plane as shown below. In this position good results can be achieved in up to three bands as shown in the performance table.

Please contact info@antenna for technical advice on getting the best results from Flavus into your product.

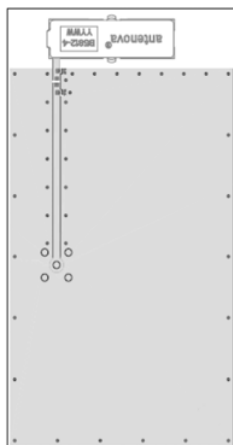

Space Saving Performance

	Typical performance	Conditions
Peak gain	1.4dBi	Space Saving Layout Data given for the 880MHz-960MHz and 1710MHz-1990MHz frequency ranges
Average gain	-3.5dBi	
Average efficiency	45%	
Maximum Return Loss	-3.0dB	
Maximum VSWR	5.9:1	

10-5 Reference board

The reference board has been designed for evaluation purposes of Flavus GSM and it includes a SMA female connector. The reference board is available with Flavus tuned to cover 5 bands: GSM850/900/1800/1900 and WCDMA , Part number : B5812-U1.

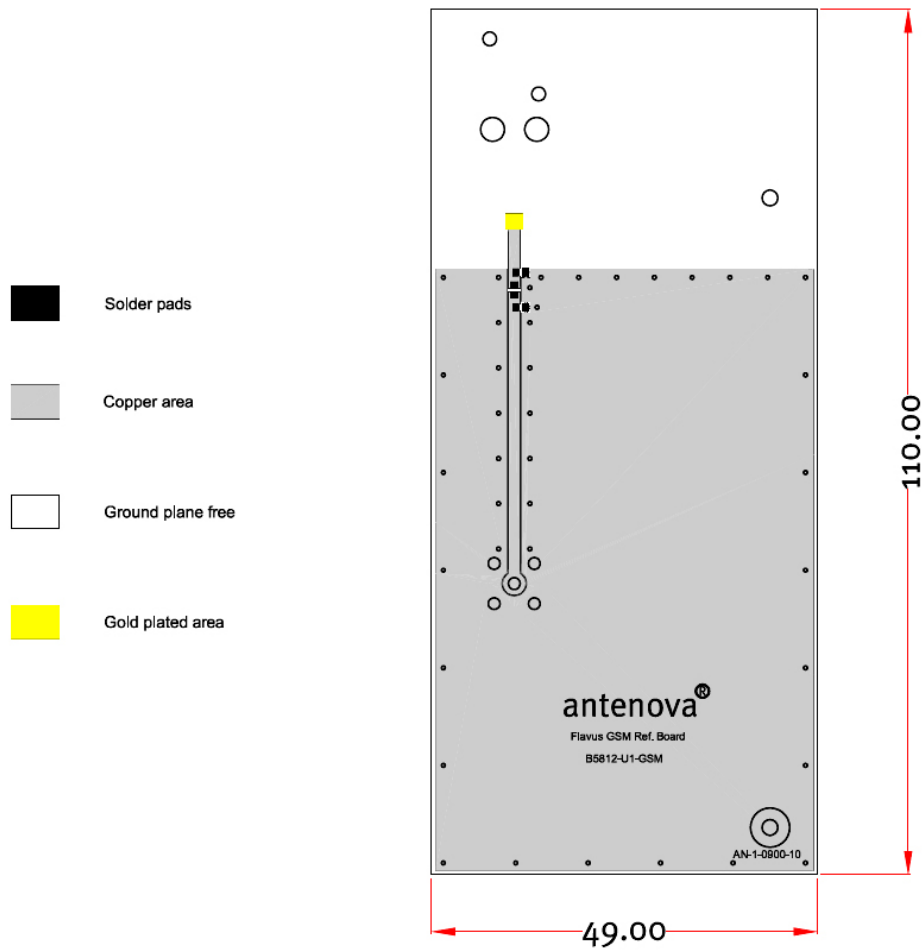

Dimensions in mm

To order a reference board contact info@antenna.com

11 Hazardous material regulation conformance

The antenna has been tested to conform to RoHS requirements. A certificate of conformance is available from Antenova's website.

12 Packaging

12-1 Optimal storage conditions

Temperature	-10°C to 40°C
Humidity	Less than 75% RH
Shelf Life	12 Months
Storage place	Away from corrosive gas and direct sunlight

12-2 Packaging information

The antennas are delivered in trays of 140 pieces packaged in boxes of 980 pieces.

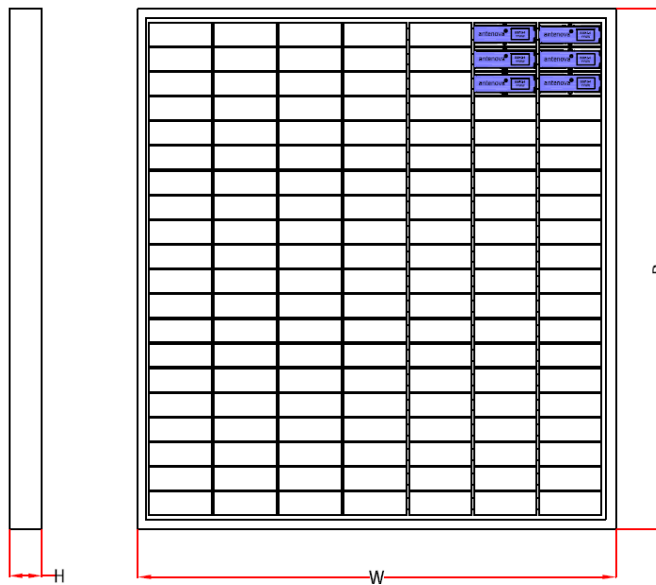

Quantity	Number of Trays	Tray Quantity
980 pcs/box	7/Box	140 pcs

12-3 Box label information

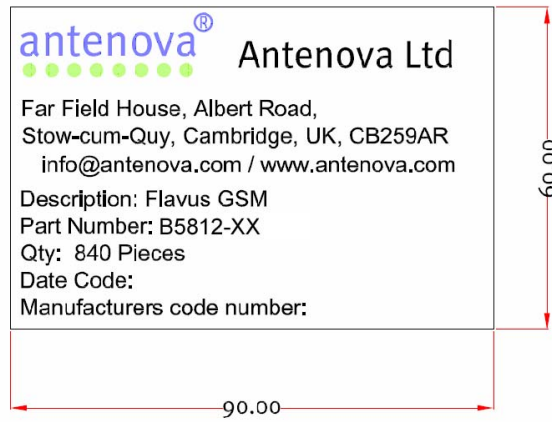

Dimensions in mm



www.antenova.com

Corporate Headquarters

Antenova Ltd.
Far Field House
Albert Road
Stow-cum-Quy
Cambridge
CB25 9AR
UK

Tel: +44 1223810600
Fax: +44 1223 810650
Email: info@antenova.com

North America Headquarters

Antenova Ltd.
Rogers Business Park
2541 Technology Drive Suite 403
Elgin, IL 60124
USA

Tel: +1 (847) 551 9710
Fax: +1 (847) 551 9719
Email: info@antenova.com

Asia Headquarters

Antenova Asia Ltd.
4F, No. 324, Sec. 1, Nei-Hu Road
Nei-Hu District
Taipei 11493
Taiwan, ROC

Tel: +886 (0) 2 8797 8630
Fax: +886 (0) 2 8797 6890
Email: info@antenova.com

Copyright® 2009 Antenova Ltd. All Rights Reserved. Antenova® and gigaNOVA® are trademarks of Antenova Ltd. Any other names and/or trademarks belong to their respective companies.

The materials provided herein are believed to be reliable and correct at the time of print. Antenova does not warrant the accuracy or completeness of the information, text, graphics or other items contained within these information. Antenova further assumes no responsibility for the use of this information, and all such information shall be entirely at the user's risk.



Certificate No: 4598

Integrated Antenna and RF Solutions