

REVISIONS			
LTR	DESCRIPTION	DATE	APPROVED
N\C	INITIAL RELEASE PER DCR# T-21465	5/29/97	M.HOBSON
A	REVISED PER DCR# T21661	97OCT17	M.HOBSON

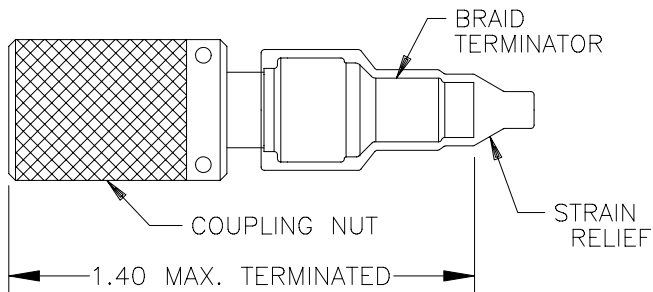

PLUG ASSEMBLY: D-621-0911

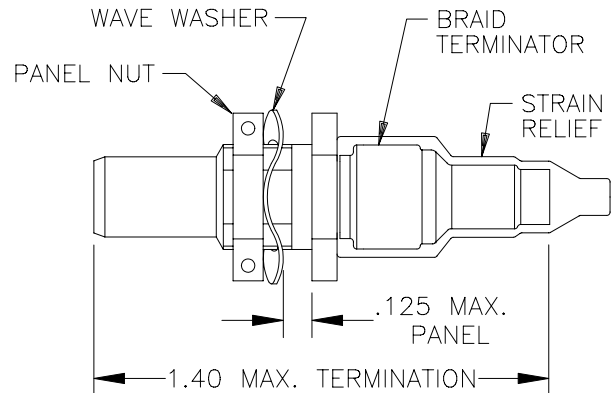

JACK ASSEMBLY: D-621-0912

NOTES:

1.0 REFER TO THE FOLLOWING RAYCHEM SPECIFICATION CONTROL DRAWINGS (SCD) FOR INDIVIDUAL COMPONENT DETAILS.

- |                 |   |
|-----------------|---|
| D-621-0911/0912 | CONNECTOR, TRIAXIAL, THREADED, COUPLED. |
| D-602-0126      | CONTACT, PIN, TWISTED PAIR              |
| D-602-0127      | CONTACT, SOCKET, TWISTED PAIR           |
| (D-600-0032)    | BRAID TERMINATOR                        |
| (D-600-0919)    | LOW OUTGASSING STRAIN RELIEF            |

2.0 CONNECTORS ARE QUALIFIED TO RAYCHEM SPECIFICATION D-6025.

3.0 TERMINATION PROCEDURE: RAYCHEM ES 61162.

## SPECIFICATION CONTROL DRAWING

UNLESS OTHERWISE SPECIFIED DIMENSIONS ARE IN INCHES. METRIC DIMENSIONS ARE IN BRACKETS.  DECIMALS .XXX ± — [ — mm] .XX ± — [ — mm] ANGLES .X — ± — WEIGHT — lbs [ — g]	DRAWN ZS.O. 97MAY29		Tyco Electronics Corporation 300 Constitution Drive Menlo Park, CA. 94025 U.S.A.	
	REDRAWN MHOBSON 97JUL3			
	APPROVED			
	APPROVED			
CAD NAME T21661A	TITLE KITS FOR D-621-0911/0912 TRIAXIAL CONNECTORS MIL-STD-1553			
THIRD ANGLE PROJECTION 	SIZE A	CODE IDENT. NO. 06090	DWG. NO. DK-621-0911/0912-X	REV A
DO NOT SCALE THIS DRAWING			SHEET 1 OF 2	

TABULATION TABLE		
KIT	CONNECTOR	CONTACT, TWINAXIAL
DK-621-0911-P	PLUG	PIN
DK-621-0911-S	PLUG	SOCKET
DK-621-0912-P	JACK	PIN
DK-621-0912-S	JACK	SOCKET

CAD NAME: T21661B	DRAWN	ZS.O.	97MAY29	SIZE	CODE IDENT. NO.	DWG. NO.	REV
	ISSUED			A	06090	DK-621-0911/0912-X	A
DO NOT SCALE THIS DRAWING						SHEET 2 OF 2	