

**MGH1V
(HB1Vxx-LP)
Series**

**REV
M**



**Product
Description**

**10/100BASE-T Magnetics, VoIP/Power Applications
Single Port, Surface Mount Modules**

Standard Features

- Single port interface for 10/100Mbps Ethernet applications
- Cable side data pairs capable to 350MA DC
- Designed for IP phone or switch applications
- Compact footprint
- Low profile package
- Compliant with IEEE 802.3 and ANSI X3.263 Standards
- OCL of 350uH min. when biased at 8mA from 0°C to 70°C
- Surface mount package designed for reflow process (240°C peak)
- Tape and Reel packaging is standard
- Package molding using UL94-V0 rated material

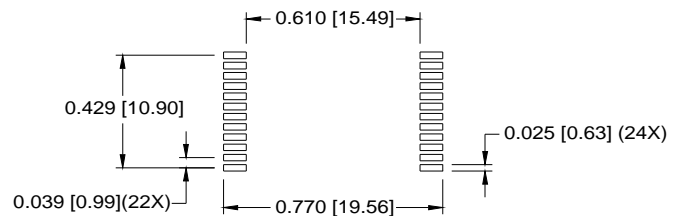
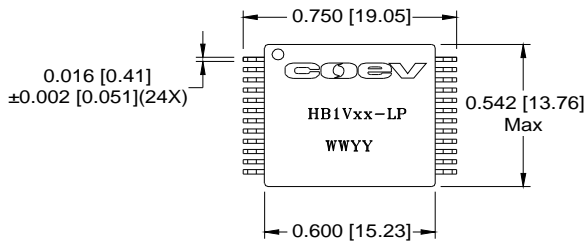

Suggested Pad Layout

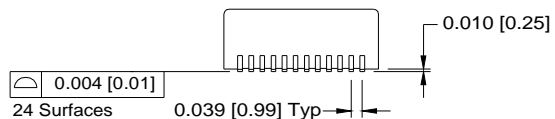
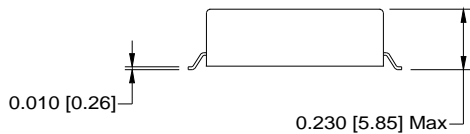

All dimensions are in inches [millimeters].
All dimensions are ±0.005 [0.127] unless otherwise noted.

The information contained in this drawing is the sole property of Tyco Electronics Corporation

TEL 888-978-2638 - FAX 605-886-8995 - Specifications subject to change without notice. For latest revision visit www.tycopowercomponents.com

**MGH1V
(HB1Vxx-LP)
Series**

**REV
M**



**Product
Description**

**10/100BASE-T Magnetics, VoIP/Power Applications
Single Port, Surface Mount Modules**

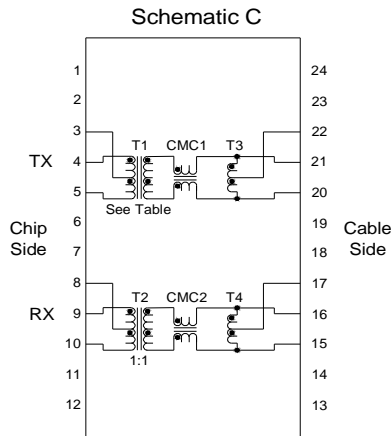
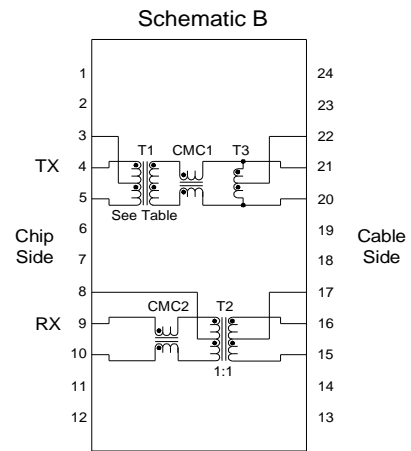
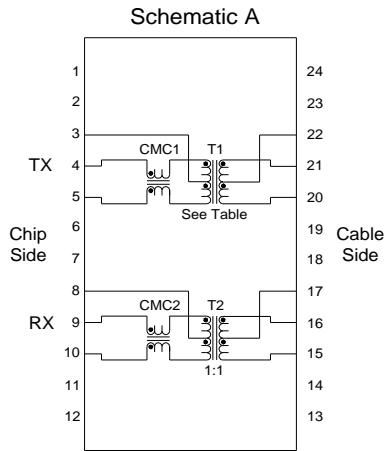

Part Number Table

Part Number	TX Turns Ratio	Schematic
HB1V09-LP	1.41:1	C
HB1V14-LP	1:1	B
HB1V15-LP	1:1	C
HB1V26-LP	1:1	A
HB1V38-LP	1.41:1	B
HB1V39-LP	1.41:1	A

10/100BASE-T Electrical Characteristics @ 25°C

Inductance: 350uH Min with 8mADC Bias, 0°C to +70°C
(each transformer measured on the cable side)

Dielectric Isolation: 1500Vrms Minimum

Frequency	Insertion Loss (dB Max)	Return Loss (dB Min) (Note 1)	Crosstalk Attenuation (dB Min)	Transmit CMRR (dB Min)	Receive CMRR (dB Min)
0.1MHz - 1MHz	1.0	18.0	43.0	42.0	42.0
1.1MHz - 15MHz	0.5	18.0	43.0	42.0	42.0
15.1MHz - 30MHz	0.8	18.0	43.0	42.0	42.0
30.1MHz - 60MHz	0.8	12.0 @ 60Mhz	43.0	42.0	42.0
60.1MHz - 80MHz	1.2	12.0 @ 80MHz	38.0	38.0	38.0
80.1MHz - 100MHz	1.4	10.0 @ 100MHz	38.0	35.0	35.0

Notes:

- 1) Minimum return loss is as follows with a circuit impedance of 100 Ohms +/- 15%:
 0.1Mhz - 29.9MHz = 18dB
 30Mhz - 60MHz = 18 - 20Log₁₀(f/30) dB where f is in MHz
 60Mhz - 80MHz = 12dB
 80.1Mhz - 100MHz = 10dB

The information contained in this drawing is the sole property of Tyco Electronics Corporation.

TEL 888-978-2638 - FAX 605-886-8995 - Specifications subject to change without notice. For latest revision visit www.tycopowercomponents.com