

VAL-CP-2S-350 VF

Order No.: 2859592



<http://eshop.phoenixcontact.de/phoenix/treeViewClick.do?UID=2859592>

Leakage current free pluggable type 2 arrester (surge arrester) for 2-phase current supply networks with separate N and PE (4-conductor system: L1, L2, N, PE), with remote indication contact. Overall width: 36 mm.



Commercial data	
GTIN (EAN)	 4 017918 980580
Note	Made-to-order
sales group	J020
Pack	1 pcs.
Customs tariff	85363030
Catalog page information	Page 29 (TT-2009)

Product notes

WEEE/RoHS-compliant since:
06/03/2006



<http://www.download.phoenixcontact.com>
 Please note that the data given here has been taken from the online catalog. For comprehensive information and data, please refer to the user documentation. The General Terms and Conditions of Use apply to Internet downloads.

Technical data	
Standards	
Housing material	PBT
Inflammability class acc. to UL 94	V0
Color	gray

Standards for air and creepage distances	DIN VDE 0110-1
	IEC 60664-1: 1992-10
	IEC 61643-1
Surge voltage category	III
Pollution degree	2
Degree of protection	IP20
Mounting type	DIN rail: 35 mm
Design	DIN rail module, two-section, divisible
Number of positions	3
Ambient temperature (operation)	-40 °C ... 80 °C
Message: Surge protection fault	Optical, remote indicator contact
Direction of action	2L-N & N-PE
Width	37.25 mm
Height	70.00 mm
Length	98.50 mm

Protective circuit

IEC category	II
	T2
EN type	T2
Nominal voltage U_N	240 V AC (230/400 V AC ... 240/415 V AC)
	415 V AC (L-L)
Arrester rated voltage U_C (L-N)	350 V AC
Arrester rated voltage U_C (N-PE)	264 V AC
U_T (TOV-proof)	350 V AC (5 s)
	1200 V AC (200 ms / N-PE)
Nominal frequency f_N	50 Hz
	60 Hz
Nominal load current I_L	40 A (biconnect, 6 mm ²)
	63 A (2 x 10 mm ²)
Ground conductor current I_{PE}	≤ 1 μA (ground conductor current I_{PE})
Standby power consumption P_C	≤ 0.35 mW
Max. discharge surge current I_{max} (8/20) μs maximum (L-N)	40 kA (all channels)
Max. discharge surge current I_{max} (8/20) μs maximum (N-PE)	40 kA

Nominal discharge surge current I_n (8/20) μ s (L-N)	20 kA (all channels)
Nominal discharge surge current I_n (8/20) μ s (N-PE)	20 kA
Impulse operate voltage at 6 kV (1.2/50) μ s (L-N)	≤ 1.5 kV
Impulse operate voltage at 6 kV (1.2/50) μ s (N-PE)	≤ 1.5 kV
Protection level U_p (L-N)	≤ 1.5 kV
Protection level U_p (N-PE)	≤ 1.5 kV
Residual voltage (L-N)	≤ 1.1 kV (at I_n) ≤ 1 kV (at 5 kA) ≤ 0.9 kV (at 3 kA)
Residual voltage (L-PE)	≤ 1.3 kV (at I_n) ≤ 1.1 kV (at 5 kA) ≤ 1 kV (at 3 kA)
Residual voltage (N-PE)	≤ 0.3 kV (at I_n) ≤ 0.25 kV (at 5 kA) ≤ 0.2 kV (at 3 kA)
Clamping voltage SVR (L-N)	≤ 1.2 kV
Clamping voltage SVR (L-PE)	≤ 1.5 kV
Clamping voltage SVR (N-PE)	≤ 1.2 kV
Response time (L-N)	≤ 100 ns
Response time (L-PE)	100 ns
Response time (N-PE)	≤ 100 ns
Max. required backup fuse with branch wiring	125 A (gL/gG)
Max. required backup fuse with V-type through wiring	40 A (gL/gG)
Short-circuit resistance I_p with max. backup fuse (effective)	25 kA
Follow current quenching capacity I_f (N-PE)	100 A

Connection, protective circuit

Connection method	Screw connection
Connection type IN	Biconnect screw terminal block
Connection type OUT	Biconnect screw terminal block
Connection method	Biconnect terminal block
Screw thread	M5
Tightening torque	4.5 Nm
Stripping length	16 mm

Conductor cross section stranded min.	2.5 mm ²
Conductor cross section stranded max.	16 mm ²
Conductor cross section solid min.	2.5 mm ²
Conductor cross section solid max.	25 mm ²
Conductor cross section AWG/kcmil min.	12
Conductor cross section AWG/kcmil max	4

Remote indicator contact

Connection name	Remote fault indicator contact
Switching function	PDT contact
Connection method	Pluggable screw connection
Screw thread	M2
Tightening torque	0.25 Nm
Stripping length	7 mm
Conductor cross section stranded min.	0.14 mm ²
Conductor cross section stranded max.	1.5 mm ²
Conductor cross section solid min.	0.14 mm ²
Conductor cross section solid max.	1.5 mm ²
Conductor cross section AWG/kcmil min.	28
Conductor cross section AWG/kcmil max	16
Maximum operating voltage U _{max} AC	250 V AC
Maximum operating voltage U _{max} DC	125 V DC
Max. operating current I _{max}	1 A AC (inductive)
	1 A AC (ohmic)
	30 mA DC (inductive)
	200 mA DC (ohmic)

Standards

Standards/regulations	IEC 61643-1 2005
	DIN EN 61643-11 2002
	DIN EN 61643-11/A11 2007
	IEEE C62.1 / C62.34 / C62.45
	UL 1449

Certificates / Approvals



Certification

CB, CUL, GOST, KEMA, UL

Accessories

Item	Designation	Description
Bridges		
2880684	MPB SET VAL-CP-3S	Wiring bridge set, consisting of three flexible bridges 15 cm black, 1 bridge 27 cm blue.
Marking		
0811228	X-PEN 0,35	Marker pen without ink cartridge, for manual labeling of markers, labeling extremely wipe-proof, line thickness 0.35 mm
0809735	ZBF 12:UNBEDRUCKT	Zack strip, flat, unprinted, 5-section, divisible, for labeling by the customer
0803595	ZBFM 5/WH:UNBEDRUCKT	Zack marker sheet, flat, unprinted: 120-section, 10 strips à 12 markers, sufficient for 120 terminal blocks, for all terminal blocks, pitch 5.2 mm, labeling with M-PEN or CMS system, color: white

Diagrams/Drawings

Dimensioned drawing

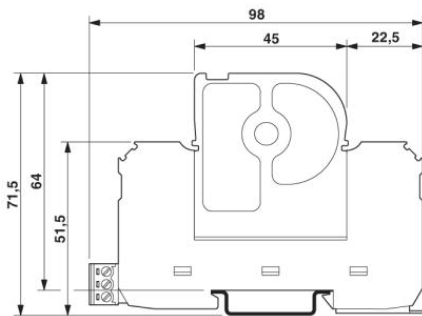

Circuit diagram

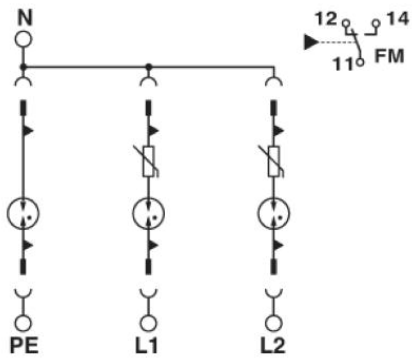

Address

PHOENIX CONTACT Inc., USA
586 Fulling Mill Road
Middletown, PA 17057, USA
Phone (800) 888-7388
Fax (717) 944-1625
<http://www.phoenixcon.com>



© 2011 Phoenix Contact
Technical modifications reserved;