

FLT-CP-PLUS-1S-350

Order No.: 2882682



<http://eshop.phoenixcontact.de/phoenix/treeViewClick.do?UID=2882682>

Pluggable lighting current arrester, in acc. with type 1/class I/B for 1-phase power supply networks with separately installed PE and N (L1, PE, N).



Commercial data	
GTIN (EAN)	 4 046356 098205
sales group	J010
Pack	1 pcs.
Customs tariff	85363010
Catalog page information	Page 15 (TT-2009)

Product notes

WEEE/RoHS-compliant since:
05/09/2006



<http://www.download.phoenixcontact.com>
Please note that the data given here has been taken from the online catalog. For comprehensive information and data, please refer to the user documentation. The General Terms and Conditions of Use apply to Internet downloads.

Technical data	
Standards	
Housing material	PBT
Inflammability class acc. to UL 94	V0
Color	gray

Standards for air and creepage distances	EN 60664-1
	IEC 60664-1: 1992-10
	IEC 61643-11
Degree of protection	IP20
Mounting type	DIN rail: 35 mm
Design	DIN rail module, two-section, divisible
Number of positions	2
Ambient temperature (operation)	-40 °C ... 80 °C
Message: Surge protection fault	Optical, remote indicator contact
Direction of action	1L-N & N-PE
Width	71.60 mm
Height	70.00 mm
Length	95.80 mm
Pitch unit	4 Div.

Protective circuit

IEC category	I
	T1
EN type	T1
Lightning protection class	III-IV /50 kA (TT, TN-C-S)
Nominal voltage U_N	240 V AC (230/400 V AC ... 240/415 V AC)
Arrester rated voltage U_C (L-N)	350 V AC
Arrester rated voltage U_C (N-PE)	350 V AC
U_T (TOV-proof)	415 V (5 s)
	1200 V AC (200 ms / N-PE)
Nominal frequency f_N	50 Hz (60 Hz)
Nominal load current I_L	125 A ($\leq 55^\circ\text{C}$)
Ground conductor current I_{PE}	$\leq 5 \mu\text{A}$
Standby power consumption P_C	$\leq 3 \text{ mVA}$
Nominal discharge surge current I_n (8/20) μs (L-N)	25 kA
Nominal discharge surge current I_n (8/20) μs (N-PE)	100 kA
Lightning test current (10/350) μs , charge	25 As
Lightning test current (10/350) μs , specific energy	625.00 kJ/ Ω
Lightning test current (10/350) μs , peak value I_{imp}	50 kA
Lightning test current (10/350) μs , charge	12.5 As

Lightning test current (10/350) μ s, specific energy	160.00 kJ/ Ω (L-N)
Lightning test current (10/350) μ s, peak value I_{imp}	25 kA (per channel L-N)
Impulse operate voltage at 6 kV (1.2/50) μ s (N-PE)	≤ 1.5 kV
Protection level U_p (L-N)	≤ 1.5 kV
Protection level U_p (L-PE)	≤ 2.5 kV
Protection level U_p (N-PE)	≤ 1.5 kV
Response time (L-N)	≤ 100 ns
Response time (L-PE)	≤ 100 ns
Response time (N-PE)	≤ 100 ns
Max. required backup fuse with branch wiring	315 A (gL/gG)
Max. required backup fuse with V-type through wiring	125 A (gL/gG)
Recommended backup fuse maximum	160 A (gL/gG, 125 A with serial through wiring)
Short-circuit resistance I_p with max. backup fuse (effective)	50 kA
Short-circuit current self-quenching	100 A (effective (N-PE))
Follow current quenching capacity I_f (L-N)	50 kA (264 V AC)
	25 kA (350 V AC)
Follow current quenching capacity I_f (N-PE)	100 A

Connection, protective circuit

Connection method	Screw terminal blocks
Connection type IN	Biconnect screw terminal block
Connection type OUT	Biconnect screw terminal block
Connection method	Biconnect terminal block
Screw thread	M5
Tightening torque	4.5 Nm
Stripping length	18 mm
Conductor cross section stranded min.	2.5 mm ²
Conductor cross section stranded max.	25 mm ²
Conductor cross section solid min.	2.5 mm ²
Conductor cross section solid max.	35 mm ²
Conductor cross section AWG/kcmil min.	13
Conductor cross section AWG/kcmil max	2

Remote indicator contact

Connection name	Remote fault indicator contact
-----------------	--------------------------------

Switching function	PDT contact
Connection method	Plug-in/screw connection via COMBICON
Screw thread	M2
Tightening torque	0.25 Nm
Stripping length	7 mm
Conductor cross section stranded min.	0.14 mm ²
Conductor cross section stranded max.	1.5 mm ²
Conductor cross section solid min.	0.14 mm ²
Conductor cross section solid max.	1.5 mm ²
Conductor cross section AWG/kcmil min.	28
Conductor cross section AWG/kcmil max	16
Maximum operating voltage U _{max.} AC	250 V AC
Maximum operating voltage U _{max.} DC	125 V DC
Max. operating current I _{max}	1 A AC (inductive)
	1 A AC (ohmic)
	30 mA DC (inductive)
	200 mA DC (ohmic)
Min. permissible switching capacity	0.12 VA (12 V, 10 mA)

Standards

Standards/regulations	IEC 61643-1 2005
	EN 61643-11 2002
	EN 61643-11/A11 2007
	UL 1449 ed. 2

Certificates / Approvals



Certification

CUL, GOST, UL

Accessories

Item	Designation	Description
General		
2859686	FLT-CP-N/PE-350-ST	Type 1 / Class I / B arrester (lightning arrester) replacement plug for path N-PE, can be combined with FLASHTRAB compact series of products.
2859913	FLT-CP-PLUS-350-ST	Type 1 / Class I / B arrester (lightning arrester) replacement plug for paths L-N and L-PEN, can be combined with FLASHTRAB compact series of products.

Marking

1051993	B-STIFT	Marker pen, for manual labeling of unprinted Zack strips, smear-proof and waterproof, line thickness 0.5 mm
2749589	ZBN 18,LGS:ERDE	Marking labels, printed horizontally, strips with 5 labels, GND (grounding symbol), color: White
2749576	ZBN 18,LGS:L1-N,ERDE	Marker labels, printed horizontally, strips with 5 labels, L1, L2, L3, N, GND, color: white
0800763	ZBN 18:SO/CMS	Marker labels, 5-section, special printing, labeled according to customer requirements (Please specify the required marking with order), for terminal width: 17.5 mm, color: White
2809128	ZBN 18:UNBEDRUCKT	Unprinted marker labels, strips with 5 labels for individual labeling with M-PEN or CMS system, for terminal block width: 17.5 mm, color: White

Diagrams/Drawings

Dimensioned drawing

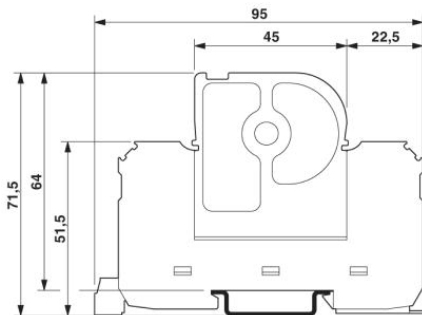

Circuit diagram

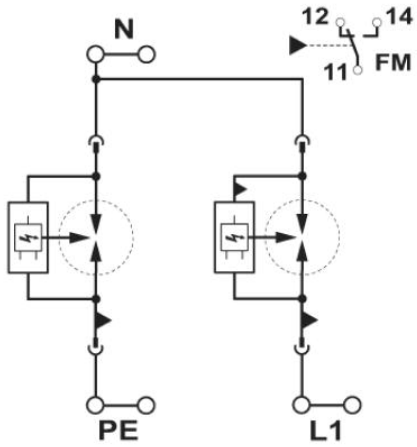

Address

PHOENIX CONTACT Inc., USA
586 Fulling Mill Road
Middletown, PA 17057, USA
Phone (800) 888-7388
Fax (717) 944-1625
<http://www.phoenixcon.com>



© 2011 Phoenix Contact
Technical modifications reserved;