

SynJet[®] Spotlight Cooler 21W

SynJet cooling technology provides the most reliable thermal management solution available. This LED cooler has been developed by Nuventix for cooling tracklight, spotlight and recessed downlight modules.

- Cools up to 21 W⁴
- Reliable 100K Hours Lifetime
- Energy Efficient
- 5 Year Warranty
- Small Form Factor
- Quiet Acoustics



Specifications¹

Thermal & Acoustic

SynJet Setting ²	Θs-a ³	TDP ⁴ (W)	SPL (dBA) ⁵	Wire Connections
High Performance	1.41	21	28	Red to +VDC Black & Blue to Ground
Standard	1.75	17	22	Red to +VDC Black only to Ground
Silent	2.33	13	18	Red to +VDC Black & Purple to Ground
PWM at 100% duty cycle	1.41	21	28	Red to +VDC Black only to Ground Blue to PWM Signal

Electrical

SynJet Setting ²	Voltage (VDC) +/- 10%	Current (mA) ⁶			Pavg (mW)	Voltage (VDC) +/- 10%	Current (mA) ⁶			Pavg (mW)
		Imin	Iavg	Ipeak			Imin	Iavg	Ipeak	
High Performance	5	20	140	280	700	12	10	71	142	850
Standard			70	140	350			42	84	500
Silent			60	120	300			38	76	450
PWM at 100% duty cycle			140	280	700			71	142	850

Environmental

All Settings	Min	Max	Units	Conditions
Operating Temperature	-40	70	°C	Air temperature surrounding cooler
Storage Temperature	-50	95	°C	Air temperature surrounding cooler
Storage Altitude		15K	m	Above sea level
Operating Relative Humidity	5	95	%	Non-condensing
Weight		300	g	SynJet with heat sink
Reliability		100K	hrs	L10 @ 60°C
Regulatory Compliance				RoHS, UL, FCC Part 15 Class B, CE

¹ All values are typical at 25°C unless otherwise stated.

² The Level Select model should be used for discrete performance settings. Follow the instructions in the Product Design Guide for adjusting settings.

³ Thermal resistance values are given as reference only and are measured in free air without airflow obstructions. Thermal resistance is measured from the bottom middle of the heat sink to ambient air measured at the inlet to the SynJet, with a heat source at least 19cm² using the 21W reference heat sink. Actual thermal performance may vary by application and final product design should be tested to assure proper thermal performance.

⁴ Thermal Design Power is based on a 30°C temperature rise of heat sink mounting surface above ambient temperature around cooler.

⁵ Sound Pressure Level is measured at 1 meter distance per ISO 7779.

⁶ The SynJet has a time varying current. The current waveform is sinusoidal and the average current (Iavg) is used to calculate the average power consumption (Pavg) at nominal input voltage (VDC). See the Electrical section in the Product Design Guide for a detailed explanation.

PRODUCT DATASHEET

Mechanical

SynJet Cooling Solution shown with HSSLS-CALCL-006

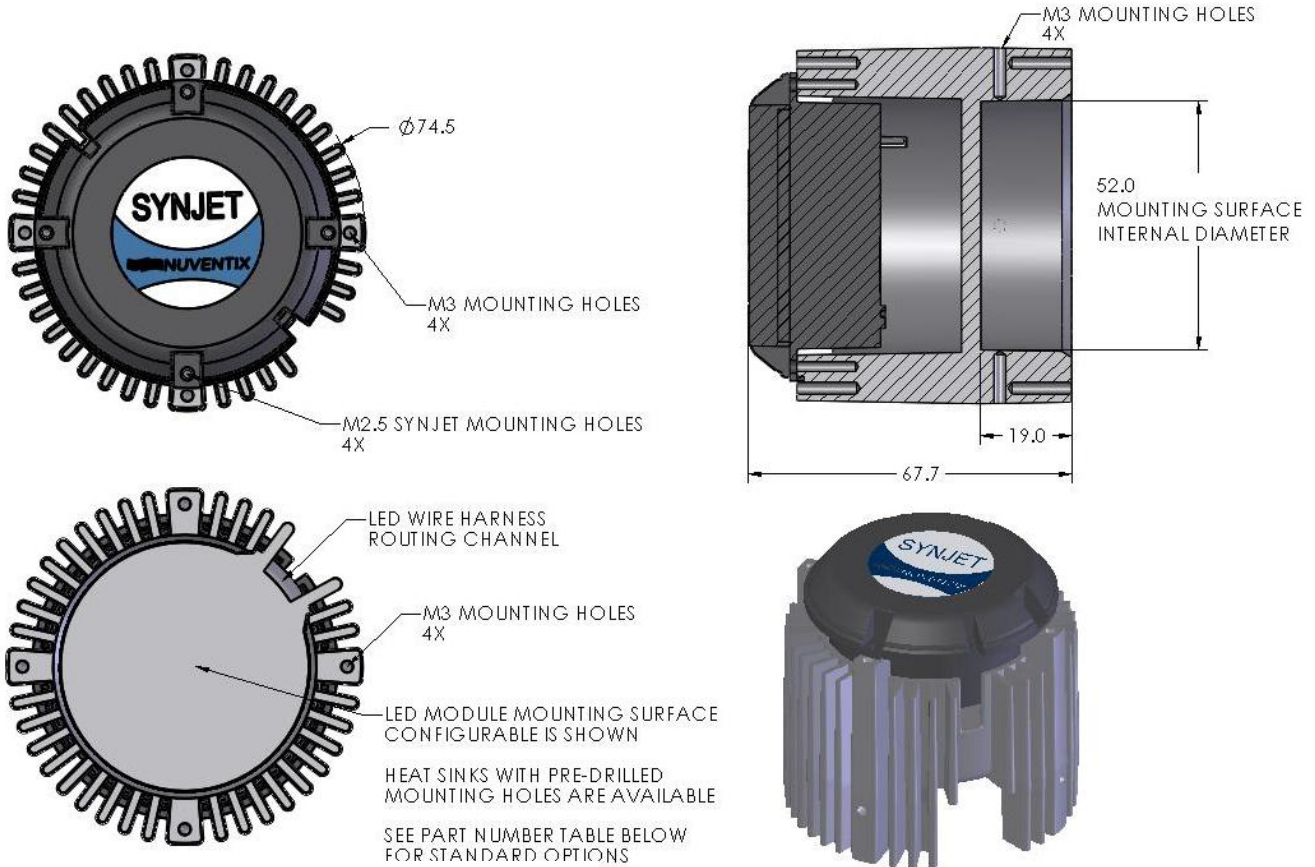

All dimensions are nominal and in mm unless otherwise stated. See product drawings for more detail.

SynJet Wire Harness

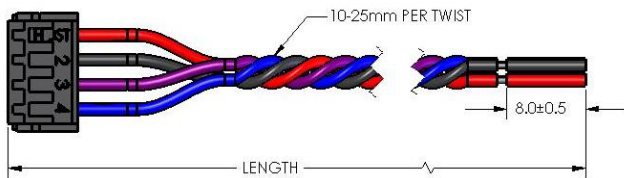

Connector Pinout

Pin	Wire Color	Symbol	Description
1	Red	+VDC	5 V or 12 V depending on model
2	Black	GND	Ground
3	Purple	CTRL2	Input for Level Select model Status signal for PWM model
4	Blue	CTRL1	Input for Level Select model PWM input for PWM model

Part Numbers

Part Number	Description	Notes
SPARS-CM005-002	SynJet, ZFlow 65 Cooler, Level Select, 5V, Black	Hard wired performance settings
SPARS-CM005-001	SynJet, ZFlow 65 Cooler, PWM, 5V, Black	Use PWM input to control performance setting
SPARS-CM012-002	SynJet, ZFlow 65 Cooler, Level Select, 12V, Black	Hard wired performance settings
SPARS-CM012-001	SynJet, ZFlow 65 Cooler, PWM, 12V, Black	Use PWM input to control performance setting
HSSLS-CALCL-005	Heatsink, 21W, Spotlight Cooler, Philips SLM, VS Opto, Stark SLE, Matte Silver	Contact sales for other heatsink options
HSSLS-CALCL-006	Heatsink, 21W, Spotlight Cooler, Configurable, Matte Silver	Contact sales for other heatsink options
HSSLS-CALCL-009	Heatsink, 21W, Spotlight Cooler, Osram PrevaLED, Matte Silver	Contact sales for other heatsink options
HSSLS-CALCL-010	Heatsink, 21W, Spotlight Cooler, Bridgelux ES, Matte Silver	Contact sales for other heatsink options
WALLS-C4150-001	Wire Harness, 4-Wire, 150 mm Length	Contact sales for other wire harness options
WALLS-C4600-001	Wire Harness, 4-Wire, 600 mm Length	Contact sales for other wire harness options

Nuventix reserves the right to make changes to the products or information contained herein without notice. No liability is assumed as a result of their use or applications. For additional information, please contact Nuventix directly.