

FCI CONFIDENTIAL

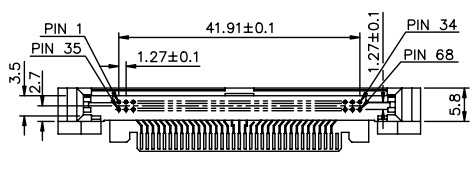

This document is the property of and includes CONFIDENTIAL and PROPRIETARY information of FCI. No part of the information shown on this document may be used in any way or disclosed to others without the written consent of FCI. Copyright FCI.

PRODUCT NO.	88640-***
	88640-***LF

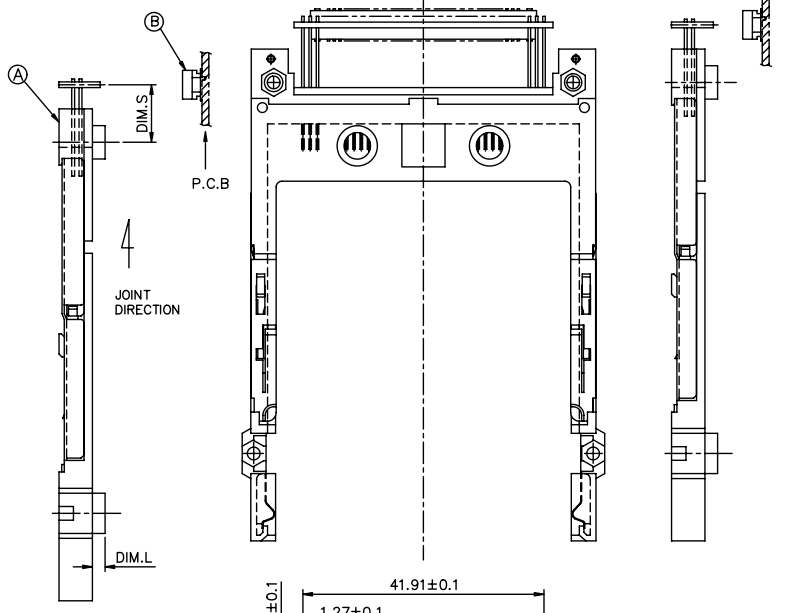
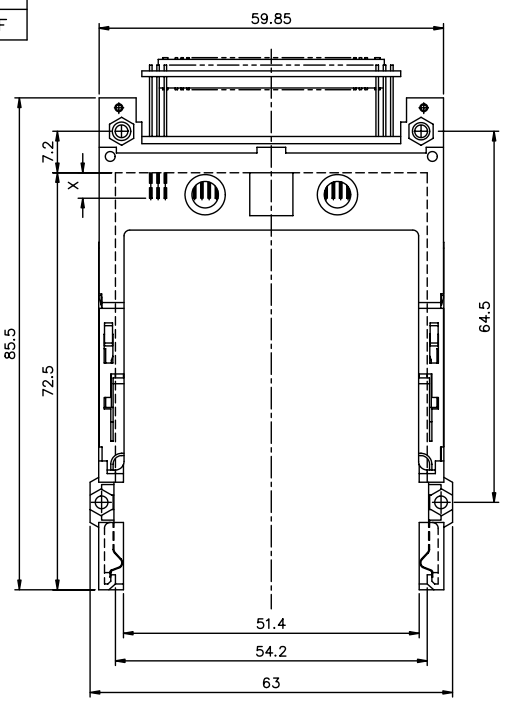

ABOVE P.C.B(P.C.B LAYOUT SEE PAGE 3,4)

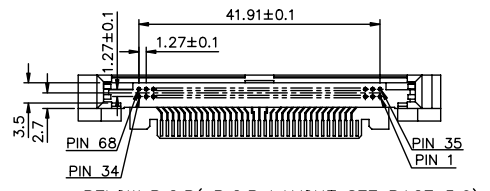

BELOW P.C.B(P.C.B LAYOUT SEE PAGE 5,6)

mat'l. code		surface		tolerance		projection		product family	
		ISO 1302		ISO 406		ISO 1012			
lfr		ecn no		date		tolerances unless otherwise specified		title	
E		T90210		W L 05/24/99		angles		EJECTOR HEADER ASS'Y	
F		T04-0205		W L 05/13/04		linear		68POS. SMT TYP 1/2/3	
G		N05-0156		W B 06/15/05		±2'		scale 1:1	
H		N08-0099		M Z 12/11/07		dr		dwg no	
						enr		88640	
						chr		sheet 1 of 6 size	
						pppd		A4	
								type	
								CUSTOMER	
								Drawing	
sheet index		revision sheet		H H H H H H					
1		2		3 4 5 6					

1 | 2 | 3 | 4 | 5 | 6

P.C.B. SIDE ①	DIM. L	③ EJ HEADER ASS'Y	④ CONAN RECEPTACLE	DIM.S	CAN BE USED FOR SINGLE DECK	P.C.B LAYOUT
BELOW	0	88640-155/155LF	91931-31169 91931-31169LF	6.55	NO	LAYOUT 6-1
	5	88640-150/150LF		-0.3	YES	LAYOUT 6-2
	0	88640-145/145LF		6.55	NO	LAYOUT 6-1
	4.3	88640-143/143LF		-0.3	YES	LAYOUT 6-2
	0	88640-125/125LF		9.0	NO	LAYOUT 5-1
	2.2	88640-122/122LF		2.15	YES	LAYOUT 5-2
	0	88640-100/100LF		10.0	NO	LAYOUT 4
ABOVE	0	88640-055/055LF	91931-31169 91931-31169LF	6.55	NO	LAYOUT 3-1
	5	88640-050H/050HLF		-0.3	YES	LAYOUT 3-2
	5	88640-050/050LF		-0.3	YES	LAYOUT 3-2
	5	88640-051/051LF		-0.3	YES	LAYOUT 3-2
	0	88640-045/045LF		6.55	NO	LAYOUT 3-1
	4.3	88640-043/043LF		-0.3	YES	LAYOUT 3-2
	0	88640-025/025LF		9.0	NO	LAYOUT 2-1
	2.2	88640-022/022LF		2.15	YES	LAYOUT 2-2
	0	88640-000/000LF		10.0	NO	LAYOUT 1

NOTES:

- P.C.B SIDE ARE AS APPEARS INSTALLED.
- MATERIAL
- 2.1 HEADER ASS'Y :
PLASTIC : HOUSING ...LCP UL94V-0 BLACK (ABOVE P.C.B)
...LCP UL94V-0 NATURAL (BELOW P.C.B)
PIN : COPPER ALLOY
PCB : FR4
- 2.2 EJECT MECHANISM ASS'Y :
PLASTIC : GUIDE: POLYPHTHARAMID UL94V-0 BLACK
PLATE : STAINLESS
EMI CONTACT: PHOSPHOR BRONZE
3. FINISH (PIN)
UNDER PLATING : 0.5 um MIN. Ni
1.27um Ni (ONLY FOR 88640-051LF)
CONTACT AREA : 0.1 um MIN. GOLD OVER 0.5 um MIN. Pd-Ni
0.76 um MIN. GOLD. (FOR 88640-051LF)
SOLDER TAIL : 2.5 um MIN. Sn-Pb
: 2.5 um MIN. PURE Sn (FOR -****LF)
4. DIM "X"

4.25±0.1	3.5±0.1	5.0±0.1
OTHERS	36,67	1,17,34,35,51,68
- DO NOT TOUCH AND KEEP CLEAN THE SURFACES OF P.C.B OF HEADER.
- ADD "H" TO PART NUMBER FOR OPTIONAL HOLD DOWN (4 PER ASSEMBLY IN EJECT MECHANISM AND HEADER)
- IF LEAD FREE P.N. THE HOUSING WILL WITHSTAND EXPOSURE TO 260°C PEAK TEMPERATURE FOR 10 SECONDS IN A WAVE SOLDER APPLICATION WITH A 1.00MM MINIMUM THICK CIRCUIT BOARD.
- IF LEAD FREE P/N. THE PRODUCT MEETS EUROPEAN UNION DIRECTIVES AND OTHER COUNTRY REGULATIONS AS DESCRIBED IN GS-22-008
- LEAD FREE P/N PACKAGING MEETS GS-14-920 SPECIFICATION

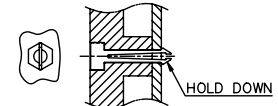

ORDERING INFORMATION

NAME	PART NO.	Q'TY
③ EJ EJECT HEADER ASS'Y	88640-XXXX	1
④ MATING RECEPTACLE	91931-31169	1

NAME	PART NO.	Q'TY
③ EJ EJECT HEADER ASS'Y	88640-XXXXLF	1
④ MATING RECEPTACLE	91931-31169LF	1

mat'l. code	surface ISO 1302	tolerance ISO 406 ISO 101	projection	product family
ltr	ecn no	dr	date	title
H				EJECTOR HEADER ASS'Y 68POS. SMT TYP 1/2/3
	angles	linear	± 0.30	MM
	± 2°			scale 1:1
	dr	WENDY CHEN	12/19/95	dwg no
	enr	JOSEPH HSIA	12/19/95	88640
	chr	JOSEPH HSIA	12/19/95	sheet 2 of 6 size
	ppd	JENN TSAO	12/19/95	A4
sheet index	revision sheet			type CUSTOMER Drawing

FCI CONFIDENTIAL

FCI

This document is the property of and includes CONFIDENTIAL and PROPRIETARY information of FCI. No part of the information shown on this document may be used in any way or disclosed to others without the written consent of FCI. Copyright FCI.

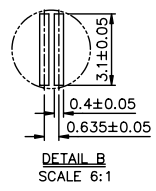
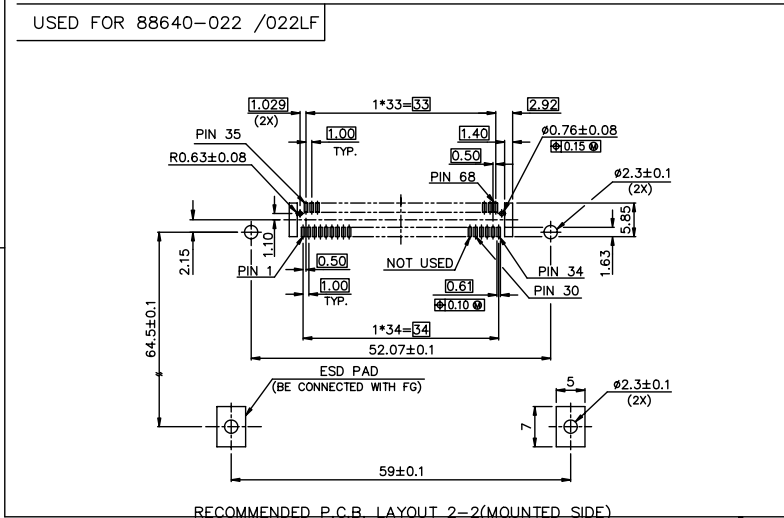
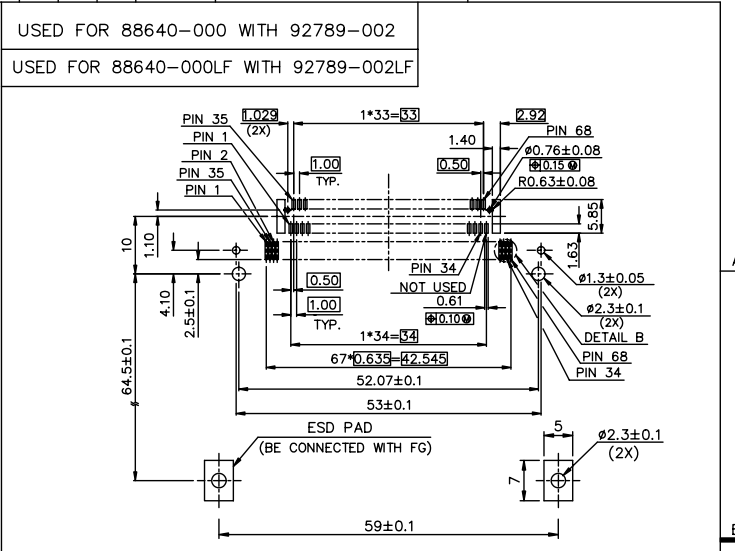
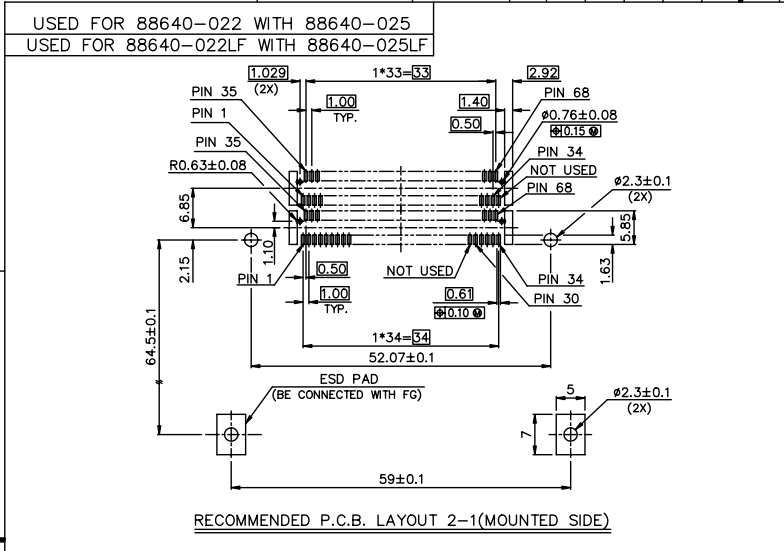

mat'l. code	surface ISO 1302	tolerance ISO 406	projection ISO 101	product family	
lfr	ecn no	dr	date	title	
H				EJECTOR HEADER ASS'Y 68POS. SMT TYP 1/2/3	
	angles	linear	± 0.30	MM	
	± 2°			scale 1:4:1	
	dr	WENDY CHEN	12/19/95		
	enr	JOSEPH HSIA	12/19/95		dwg no 88640 sheet 3 of 6 size A4
	chr	JOSEPH HSIA	12/19/95		type CUSTOMER Drawing
sheet index	revision sheet	pppd	JENN TSAO	12/19/95	

PDM: Rev:H STATUS Released Printed: Oct 12, 2010 6

FCI CONFIDENTIAL

FCI

This document is the property of and includes CONFIDENTIAL and PROPRIETARY information of FCI. No part of the information shown on this document may be used in any way or disclosed to others without the written consent of FCI. Copyright © FCI.

USED FOR 88640-043 WITH 88640-045
 USED FOR 88640-050 WITH 88640-055
 USED FOR 88640-043LF WITH 88640-045LF
 USED FOR 88640-050LF WITH 88640-055LF

USED FOR 88640-043
 USED FOR 88640-050
 USED FOR 88640-051
 USED FOR 88640-050H

USED FOR 88640-043LF
 USED FOR 88640-050LF
 USED FOR 88640-051LF
 USED FOR 88640-050HLF

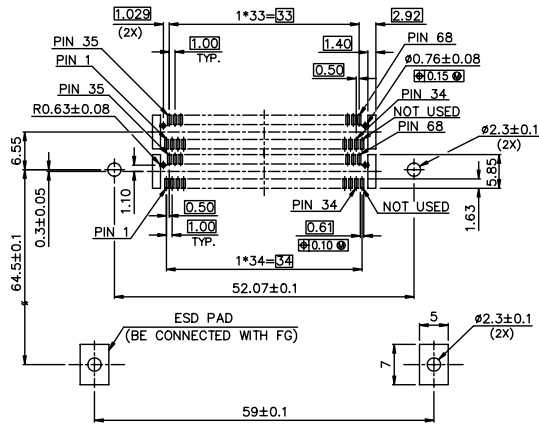

RECOMMENDED P.C.B. LAYOUT 3-1 (MOUNTED SIDE)

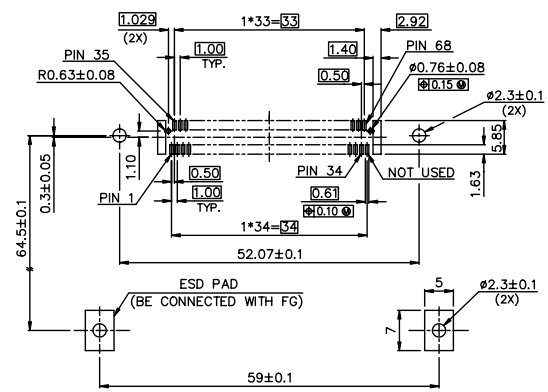

RECOMMENDED P.C.B. LAYOUT 3-2 (MOUNTED SIDE)

mat'l. code		surface	tolerance	projection	product family
ISO 1302		ISO 406	ISO 101		
ltr	ecr no	dr	date	title	
H				EJECTOR HEADER ASS'Y 68POS. SMT TYP 1/2/3	
angles		linear	± 0.30	MM	
± 2°				scale	1.5:1
dr	WENDY CHEN		12/19/95	dwg no	sheet 4 of 6 size
enr	JOSEPH HSIA		12/19/95	88640	A4
chr	JOSEPH HSIA		12/19/95	type	CUSTOMER Drawing
ppd	JENN TSAO		12/19/95		
sheet index	revision sheet				

PDM: Rev:H STATUS Released Printed: Oct 12, 2010 6

FCI CONFIDENTIAL

FCI

This document is the property of and includes CONFIDENTIAL and PROPRIETARY information of FCI. No part of the information shown on this document may be used in any way or disclosed to others without the written consent of FCI. Copyright © FCI.

USED FOR 88640-122 WITH 88640-125
USED FOR 88640-122LF WITH 88640-125LF

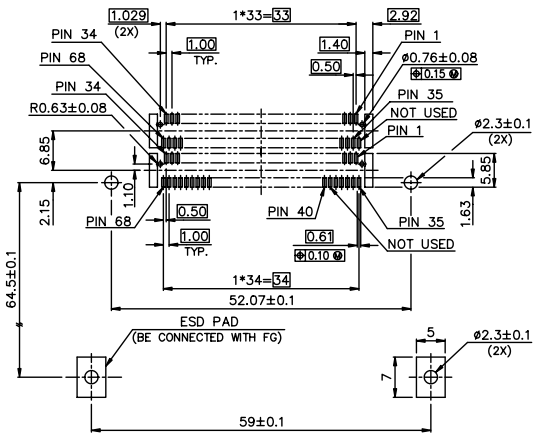

RECOMMENDED P.C.B. LAYOUT 5-1 (MOUNTED SIDE)

USED FOR 88640-100 WITH 92789-502
USED FOR 88640-100LF WITH 92789-502LF

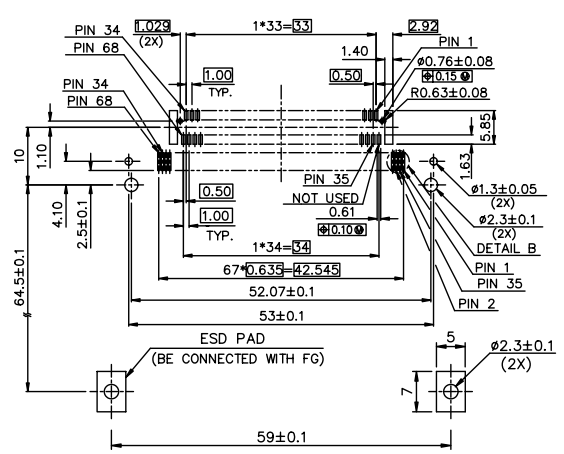

RECOMMENDED P.C.B. LAYOUT 4 (MOUNTED SIDE)

USED FOR 88640-122/122LF

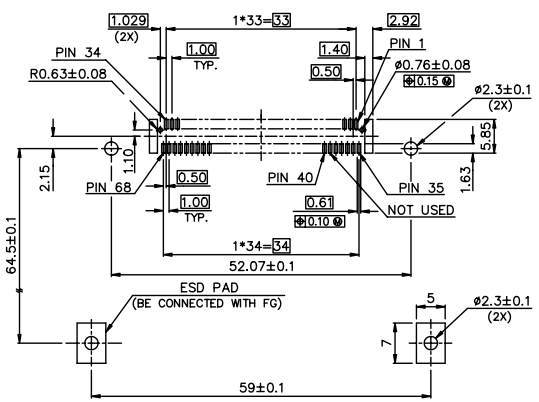

RECOMMENDED P.C.B. LAYOUT 5-2 (MOUNTED SIDE)

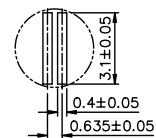

mat'l. code	surface ISO 1302	tolerance ISO 406	projection ISO 101	product family
lfr	ecn no	dr	date	title
H				EJECTOR HEADER ASS'Y 68POS. SMT TYP 1/2/3
	angles	linear	± 0.30	MM
	dr	WENDY CHEN	12/19/95	scale 1.4:1
	enr	JOSEPH HSIA	12/19/95	dwg no 88640
	chr	JOSEPH HSIA	12/19/95	sheet 5 of 6 size A4
	ppd	JENN TSAO	12/19/95	type CUSTOMER Drawing
sheet index	revision sheet			

PDM: Rev:H STATUS Released Printed: Oct 12, 2010 6

form: A3

FCI CONFIDENTIAL

FCI

This document is the property of and includes CONFIDENTIAL and PROPRIETARY information of FCI. No part of the information herein may be used in any way or disclosed to others without the written consent of FCI. Copyright FCI.

USED FOR 88640-143 WITH 88640-145
 USED FOR 88640-150 WITH 88640-155
 USED FOR 88640-143LF WITH 88640-145LF
 USED FOR 88640-150LF WITH 88640-155LF

USED FOR 88640-143
 USED FOR 88640-150
 USED FOR 88640-143LF
 USED FOR 88640-150LF

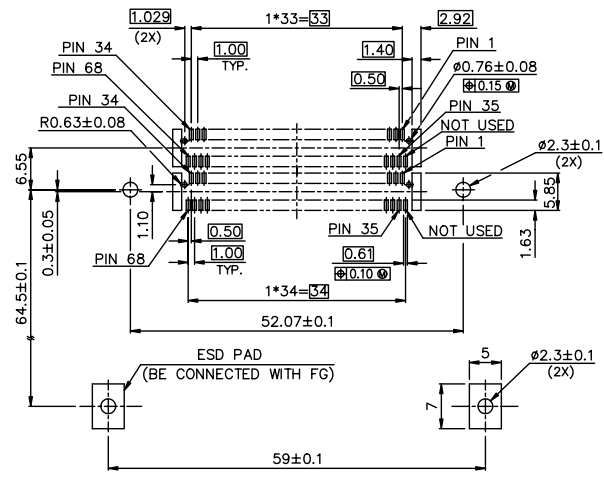

RECOMMENDED P.C.B. LAYOUT 6-1 (MOUNTED SIDE)

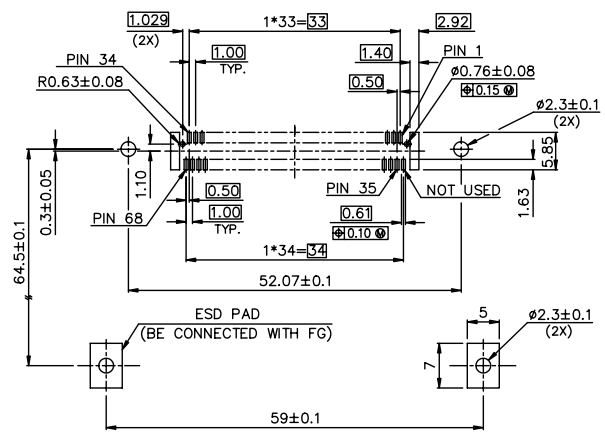

RECOMMENDED P.C.B. LAYOUT 6-2 (MOUNTED SIDE)

mat'l. code		surface		tolerance		projection		product family	
ISO 1302		ISO 406		ISO 101		MM		EJECTOR HEADER ASS'Y	
ltr		ecn no		dr		date		title	
H								EJECTOR HEADER ASS'Y	
								68POS. SMT TYP 1/2/3	
								scale 1.5 : 1	
								dwg no	
								88640	
								sheet 6 of 6 size	
								A4	
								type	
								CUSTOMER Drawing	
sheet index		revision sheet							

PDM: Rev:H STATUS: Released Printed: Oct 12, 2010 6