

PRODUCT NO	MOTOROLA P/N	DIM A	DIM B	DIM C	DIM D	DIM E	DIM F	REMARK
10067099-100LF	3971730C03	3.05MM	1.85MM	3.40MM	1.00MM	1.20MM	3.05MM	NO PROTECTION
10067099-200LF	3971730C02	2.65MM	1.45MM	3.50MM	0.90MM	1.00MM	2.95MM	NO PROTECTION
10067099-400LF	3971730C03	3.05MM	1.85MM	3.40MM	1.00MM	1.20MM	3.05MM	WITH PROTECTION

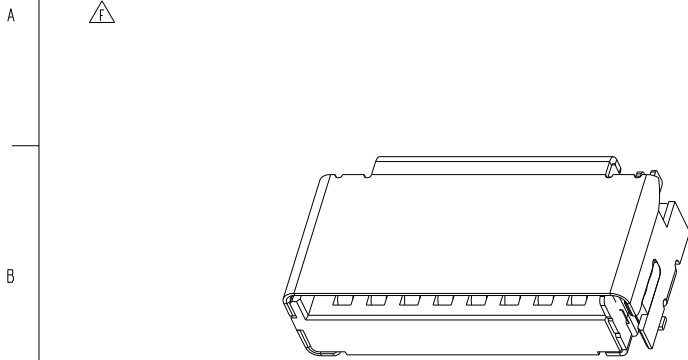

10067099-100LF/200LF

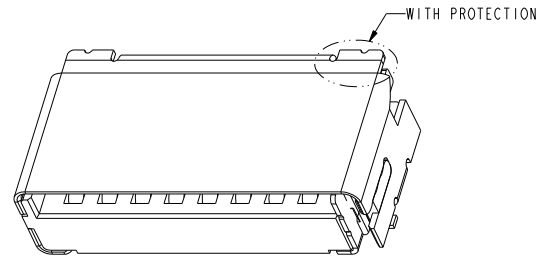

10067099-400LF

NOTES:

- MATERIAL:
HOUSING: 30% G/F LCP, UL 94V-0, COLOR: BLACK.
CONTACT & DETECT PIN: COPPER ALLOY, THICKNESS=0.15MM.
CONTACT PLATING: 50u" MIN. OF Ni UNDERPLATE, GOLD FLASH OVER ALL, CONTACT AREA PLATING 30u" GOLD.
DETECT PIN PLATING: 50u" MIN. OF Ni UNDERPLATE, GOLD FLASH ON CONTACT AREA, TIN PLATED ON SOLDER AREA.
BRACKET: STAINLESS STEEL, THICKNESS=0.20MM, GOLD FLASH ON SOLDER AREA.
- PRODUCT PERFORMANCE SPEC. PER GS-12-451.
- PACKAGE SPEC. PER GS-14-1162.
- "■" REPRESENT CRITICAL DIMS AND NEED TO MEET Cpk>1.5
- THIS PRODUCT IS RoHS COMPLIANT, AND MEETS EUROPEAN UNION DIRECTIVES AND OTHER COUNTRY REGULATIONS AS PER GS-22-008.
- A ΔSYMBOL WILL BE NEXT TO ANY DIMENSION, VIEW OR NOTE WHICH HAS BEEN MODIFIED WITH CURRENT DRAWING VERSION.

rev	ecr no	dr	date
A	0607-0087	DT	2007.03.15
B	0607-0098	DT	2007.04.04
C	0608-0005	SH	2008.01.04
D	0608-0339	SH	2008.12.04
E	0610-0457	SM	2010.12.21
F	0610-0462	SM	2010.12.28

www.fciconnect.com		surface	tolerance std	projection	MM
Dr DAVID TENG 2007-02-12		ANGULAR	0.x ±0.30	size A4	Scale 1.000
Eng DAVID TENG 2007-02-12		LINEAR	0.xx ±0.15	ECN DG10-0462	
Chr PAUL WANG 2007-02-12		0° ±2°	0.xxx ±0.08	Spec ref	
Appr Joseph Hsia 2007-02-12		Product family	Moblie I/O		
FCJ		TFLASH CONNECTOR ASSEMBLY		10067099	Rev. F
		TFLASH CONNECTOR WITH CARD DETECTING		CUSTOMER	sheet 1 of 3
		catalog no	10067099		

REV F - 2010-04-17

3PDM: Rev:F

STATUS:Released

4 Printed: Dec 29, 2010



Copyright FCJ.

PRODUCT NO	MOTOROLA P/N	DIM A	DIM B	DIM C	DIM D	DIM E	DIM F	REMARK
10067099-100LF	3971730C03	3.05MM	1.85MM	3.40MM	1.00MM	1.20MM	3.05MM	NO PROTECTION
10067099-200LF	3971730C02	2.65MM	1.45MM	3.50MM	0.90MM	1.00MM	2.95MM	NO PROTECTION

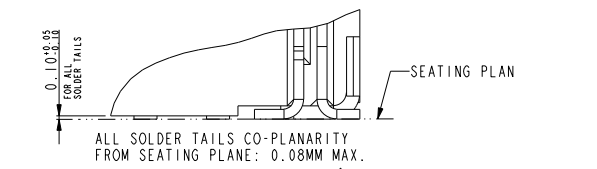
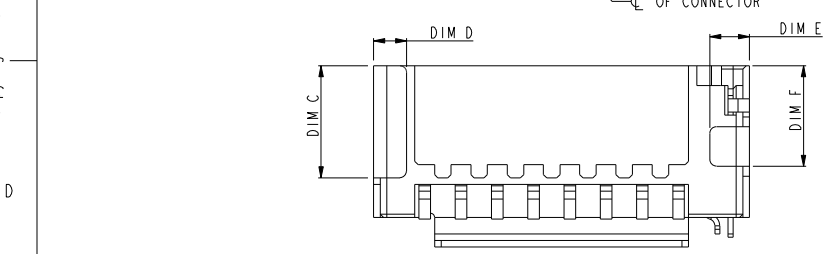
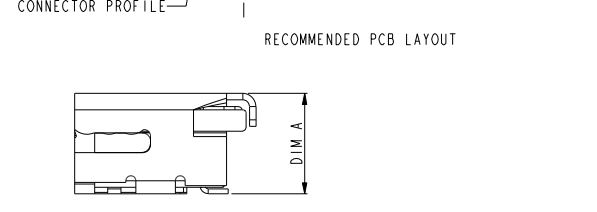
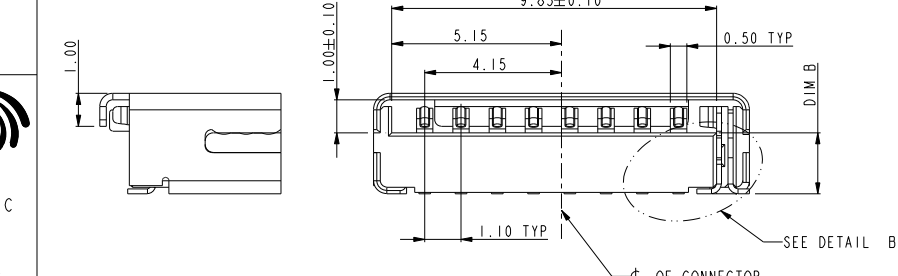
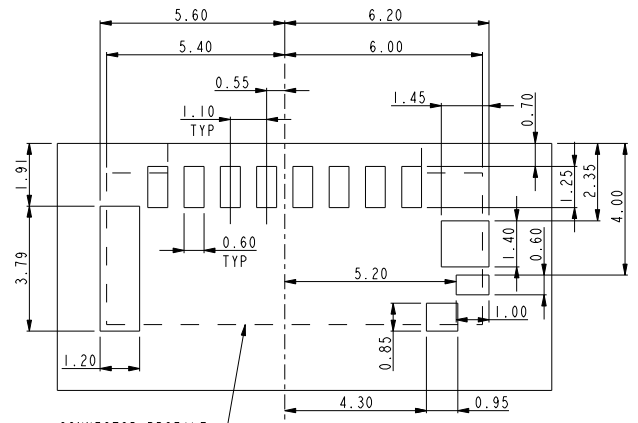
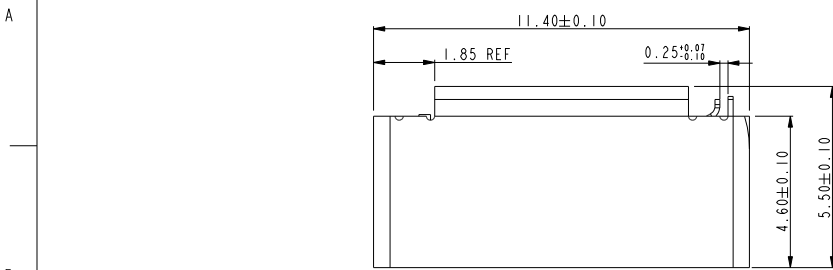

ALL SOLDER TAILS CO-PLANARITY FROM SEATING PLANE: 0.08MM MAX.

DETAIL B SCALE 12.000

TOLERANCES UNLESS OTHERWISE SPECIFIED		
LINEAR	0.X	±0.30
	0.XX	±0.15
ANGULAR	0.XXX	±0.08
	0°	±2°

SCALE 6.000

	TITLE	TFLASH CONNECTOR ASSEMBLY	dwg no	10067099	Rev.	F
		TFLASH CONNECTOR WITH CARD DETECTING				
	CATALOG NO	10067099	CUSTOMER		SHEET	2 OF 3

3 PDM: Rev:F STATUS:Released 4 Printed: Dec 29, 2010

Copyright FCI

PRODUCT NO	MOTOROLA P/N	DIM A	DIM B	DIM C	DIM D	DIM E	DIM F	REMARK
10067099-400LF	3971730C03	3.05MM	1.85MM	3.40MM	1.00MM	1.20MM	3.05MM	WITH PROTECTION

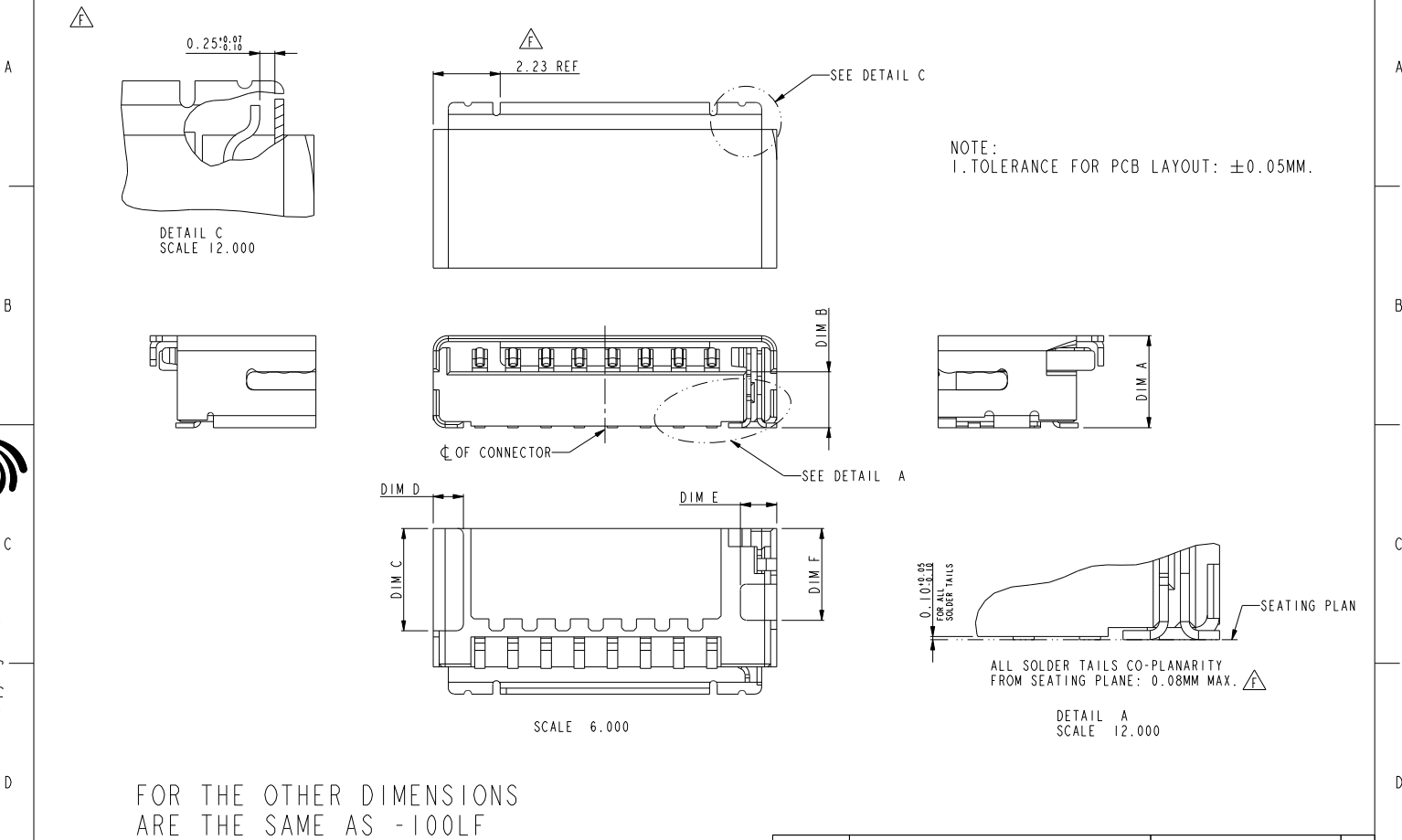

FCJ
 Copyright FCJ.

FCJ	TITLE	TFLASH CONNECTOR ASSEMBLY	Qty no	10067099	Rev.	F
		TFLASH CONNECTOR WITH CARD DETECTING	catalog no	10067099	CUSTOMER	sheet 3 of 3

3PDM: Rev:F **STATUS:Released** **4** Printed: Dec 29, 2010