

DESCRIPTION : ABOVE PCB, DECK AND PUSH ROD LOCATION ARE AS VIEW BY USER.

PRODUCT NO.	PUSH ROD LOCATION	DECK CLOSEST TO PCB	DECK FARTHEST TO PCB	STAND-OFF HEIGHT	CLOSEST TO PCB	FARTHEST FROM PCB	MATING RECEPTACLE	P.C.B SIDE	RECOMMENDED P.C.B LAYOUT (SEE PAGE 6&7)	MOUNT STYLE TO PCB AND PUSH ROD SIDE
					EJ HDR ASS'Y	EJ HDR ASS'Y				
(A) 95562-*****					(B)	(C)	(D)			
200CA/200CALF	RIGHT	RIGHT	RIGHT	0.0	95620-002CA/002CALF	95547-005CA/005CALF	RECEPTACLE PART NO. 91931-31169	ABOVE	LAYOUT 1	
220CA	RIGHT	RIGHT	RIGHT	2.2	95547-020CA	95547-025CA			LAYOUT 2	
240CA	RIGHT	RIGHT	RIGHT	4.3	95547-040CA	95547-045CA			LAYOUT 3	
250CA	RIGHT	RIGHT	RIGHT	5.0	95547-050CA	95547-055CA			LAYOUT 3	
300CA	LEFT	LEFT	LEFT	0.0	95620-102CA	95547-105CA			LAYOUT 1	
320CA	LEFT	LEFT	LEFT	2.2	95547-120CA	95547-125CA			LAYOUT 2	
340CA	LEFT	LEFT	LEFT	4.3	95547-140CA	95547-145CA	LAYOUT 3			
350CA	LEFT	LEFT	LEFT	5.0	95547-150CA	95547-155CA	LAYOUT 3			
700CA	RIGHT	RIGHT	RIGHT	0.0	95620-502CA	95547-505CA	LAYOUT 4			
720CA	RIGHT	RIGHT	RIGHT	2.2	95547-520CA	95547-525CA	LAYOUT 5			
740CA	RIGHT	RIGHT	RIGHT	4.3	95547-540CA	95547-545CA	LAYOUT 6			
750CA	RIGHT	RIGHT	RIGHT	5.0	95547-550CA	95547-555CA	LAYOUT 6			
800CA	LEFT	LEFT	LEFT	0.0	95620-602CA	95547-605CA	RECEPTACLE PART NO. 91931-31169	BELOW	LAYOUT 4	
820CA	LEFT	LEFT	LEFT	2.2	95547-620CA	95547-625CA			LAYOUT 5	
840CA	LEFT	LEFT	LEFT	4.3	95547-640CA	95547-645CA			LAYOUT 6	
850CA	LEFT	LEFT	LEFT	5.0	95547-650CA	95547-655CA			LAYOUT 6	

ORDERING INFORMATION

NAME	PART NO.	Q'TY
(A) EJECT HEADER ASS'Y	95562-*****	1
(D) MATING RECEPTACLE	91931-31169	2

OR

ORDERING INFORMATION

NAME	PART NO.	Q'TY
(B) DECK CLOSEST TO PCB	95547-*****	1
(C) DECK FARTHEST FROM PCB	95547-*****	1
(D) MATING RECEPTACLE	91931-31169	2

OR

ORDERING INFORMATION

NAME	PART NO.	Q'TY
(B) DECK CLOSEST TO PCB	95620-*****	1
(C) DECK FARTHEST FROM PCB	95547-*****	1
(D) MATING RECEPTACLE	91931-31169	1

mat'l code		tolerance unless otherwise specified		CUSTOMER COPY		FCI		www.fciconnect.com	
rev.	ecm no. dr	date	linear	± 0.30	projection	title	EJECTOR HEADER ASS'Y		
J	N05-0127	W	Bps/11/05			5.0V SMT, TYPE 1/2/3			
K	N06-0135	C	Mos/22/06						
L	N09-0091	MZ	03/19/09	angles ± 2°		product family	PCMCIA	code	1/2/3
		dr	WENDY CHEN	02/14/95	unit	mm/inch	size	dwg no.	sheet
		engr	JOSEPH HSIAO	02/14/95	scale	1:1	A3	95562	1 of 9
		chr	JOSEPH HSIAO	02/14/95					
		pppd	JENN TSAO	02/14/95					
sheet index	revision sheet	L	L	L	L	L	L	L	L
	1	2	3	4	5	6	7	8	9

Tous droits strictement réservés. Reproduction ou communication de ces liens int. sans autorisation écrite du propriétaire. FCI et FCI Connect sont des marques de propriété intellectuelle de FCI Electronics. Droits de reproduction BERG ELECTRONICS bv.

All rights strictly reserved. Reproduction or issue to third parties in any form or by any means, electronic, mechanical, photocopying, recording, or by any information storage and retrieval system, without written authority from the proprietor. FCI and FCI Connect are trademarks of FCI Electronics. Copyright BERG ELECTRONICS bv.

DESCRIPTION : ABOVE PCB, DECK AND PUSH ROD LOCATION ARE AS VIEW BY USER.

PRODUCT NO.	PUSH ROD LOCATION	DECK CLOSEST TO PCB	DECK FARTHEST TO PCB	STAND-OFF HEIGHT	CLOSEST TO PCB		FARTHEST FROM PCB		MATING RECEPTACLE	P.C.B SIDE	RECOMMENDED P.C.B LAYOUT (SEE PAGE 6&7)	MOUNT STYLE TO PCB AND PUSH ROD SIDE
					EJ HDR ASS'Y	EJ HDR ASS'Y	EJ HDR ASS'Y	EJ HDR ASS'Y				
(A) 95562-****					(B)	(C)			(D)			
200CA/200CALF	RIGHT	RIGHT	RIGHT	0.0	95620-002CA/002CALF	95547-005CA/005CALF	RECEPTACLE PART NO. 91931-31169LF	ABOVE		LAYOUT 1		
220CALF	RIGHT	RIGHT	RIGHT	2.2	95547-020CALF	95547-025CALF				LAYOUT 2		
240CALF	RIGHT	RIGHT	RIGHT	4.3	95547-040CALF	95547-045CALF				LAYOUT 3		
241CALF	RIGHT	RIGHT	RIGHT	4.3	95547-041CALF	95547-045CALF				LAYOUT 3		
250CALF	RIGHT	RIGHT	RIGHT	5.0	95547-050CALF	95547-055CALF				LAYOUT 3		
300CA	LEFT	LEFT	LEFT	0.0	95620-102CA	95547-105CA				LAYOUT 1		
320CALF	LEFT	LEFT	LEFT	2.2	95547-120CALF	95547-125CALF				LAYOUT 2		
340CALF	LEFT	LEFT	LEFT	4.3	95547-140CALF	95547-145CALF				LAYOUT 3		
350CALF	LEFT	LEFT	LEFT	5.0	95547-150CALF	95547-155CALF				LAYOUT 3		
700CA	RIGHT	RIGHT	RIGHT	0.0	95620-502CA	95547-505CA				RECEPTACLE PART NO. 91931-31169LF		BELOW
720CALF	RIGHT	RIGHT	RIGHT	2.2	95547-520CALF	95547-525CALF	LAYOUT 5					
740CALF	RIGHT	RIGHT	RIGHT	4.3	95547-540CALF	95547-545CALF	LAYOUT 6					
750CALF	RIGHT	RIGHT	RIGHT	5.0	95547-550CALF	95547-555CALF	LAYOUT 6					
800CA	LEFT	LEFT	LEFT	0.0	95620-602CA	95547-605CA	LAYOUT 4					
820CALF	LEFT	LEFT	LEFT	2.2	95547-620CALF	95547-625CALF	LAYOUT 5					
840CALF	LEFT	LEFT	LEFT	4.3	95547-640CALF	95547-645CALF	LAYOUT 6					
850CALF	LEFT	LEFT	LEFT	5.0	95547-650CALF	95547-655CALF	LAYOUT 6					

ORDERING INFORMATION

NAME	PART NO.	Q'TY
(A) EJECT HEADER ASS'Y	95562-****LF	1
(D) MATING RECEPTACLE	91931-31169LF	2

OR

ORDERING INFORMATION

NAME	PART NO.	Q'TY
(B) DECK CLOSEST TO PCB	95547-****LF	1
(C) DECK FARTHEST FROM PCB	95547-****LF	1
(D) MATING RECEPTACLE	91931-31169LF	2

OR

ORDERING INFORMATION

NAME	PART NO.	Q'TY
(B) DECK CLOSEST TO PCB	95620-****LF	1
(C) DECK FARTHEST FROM PCB	95547-****LF	1
(D) MATING RECEPTACLE	91931-31169LF	1

mat'l code		tolerance unless otherwise specified		CUSTOMER COPY				www.fciconnect.com	
rev. L	ecn no.	dr	date	linear	± 0.30	projection	title	EJECTOR HEADER ASS'Y	
				angles	± 2°		5.0V SMT, TYPE 1/2/3		
				dr	WENDY CHEN02/14/95	unit	product family	PCMCIA	code
				enrg	JOSEPH HSIA02/14/95	mm/inch	size	dwg no.	sheet
				chr	JOSEPH HSIA02/14/95	scale	A3	95562	2 of
				app	JENN TSAO02/14/95	1:1			
sheet index	revision								
	sheet								

PDM: Rev:L STATUS Released Printed: Oct 12, 2010

All rights strictly reserved. Reproduction or issue to third parties in any form or by any means without the written authority from the proprietor. Copyright © BERG ELECTRONICS by

Tous droits r serv s. Toute r impression, reproduction ou utilisation sans autorisation  crita du propri taire.   
 All rights reserved. Any reprinting or unauthorized use without written authority is prohibited.   
 Property of e BERG ELECTRONICS. Copyright BERG ELECTRONICS BV

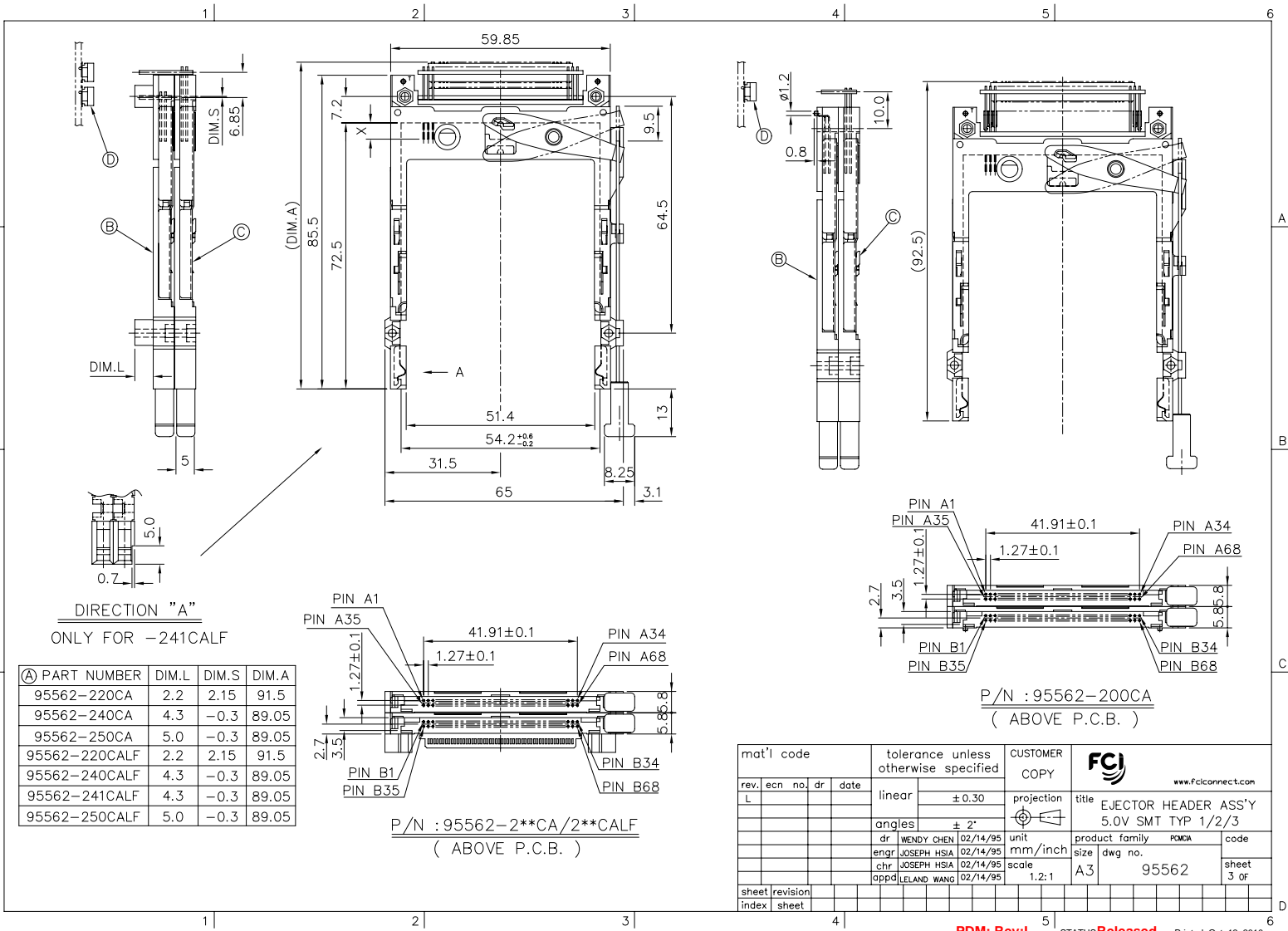

mat'l code	tolerance unless otherwise specified	CUSTOMER COPY	<b>FCj</b> www.falconconnect.com
rev. ecn no. dr date	linear ± 0.30	projection	title EJECTOR HEADER ASS'Y 5.0V SMT TYP 1/2/3
	angles ± 2°	unit mm/inch	product family PDMCA code
	dr WENDY CHEN 02/14/95	size A3	dwg no. 95562 sheet 3 of
	enrg JOSEPH HSIA 02/14/95	scale 1.2:1	
	chr JOSEPH HSIA 02/14/95		
	appd LELAND WANG 02/14/95		
sheet index	revision sheet		

PDM: Rev:L STATUS Released Printed: Oct 12, 2010

Tous droits strictement réservés. Reproduction ou communication à des tiers sans autorisation écrite du propriétaire.  
 FCJ ELECTRONICS  
 Droits de reproduction BERG ELECTRONICS by

All rights strictly reserved. Reproduction or issue to third parties in any form without the written authority from the proprietor.  
 FCJ ELECTRONICS  
 Copyright BERG ELECTRONICS by

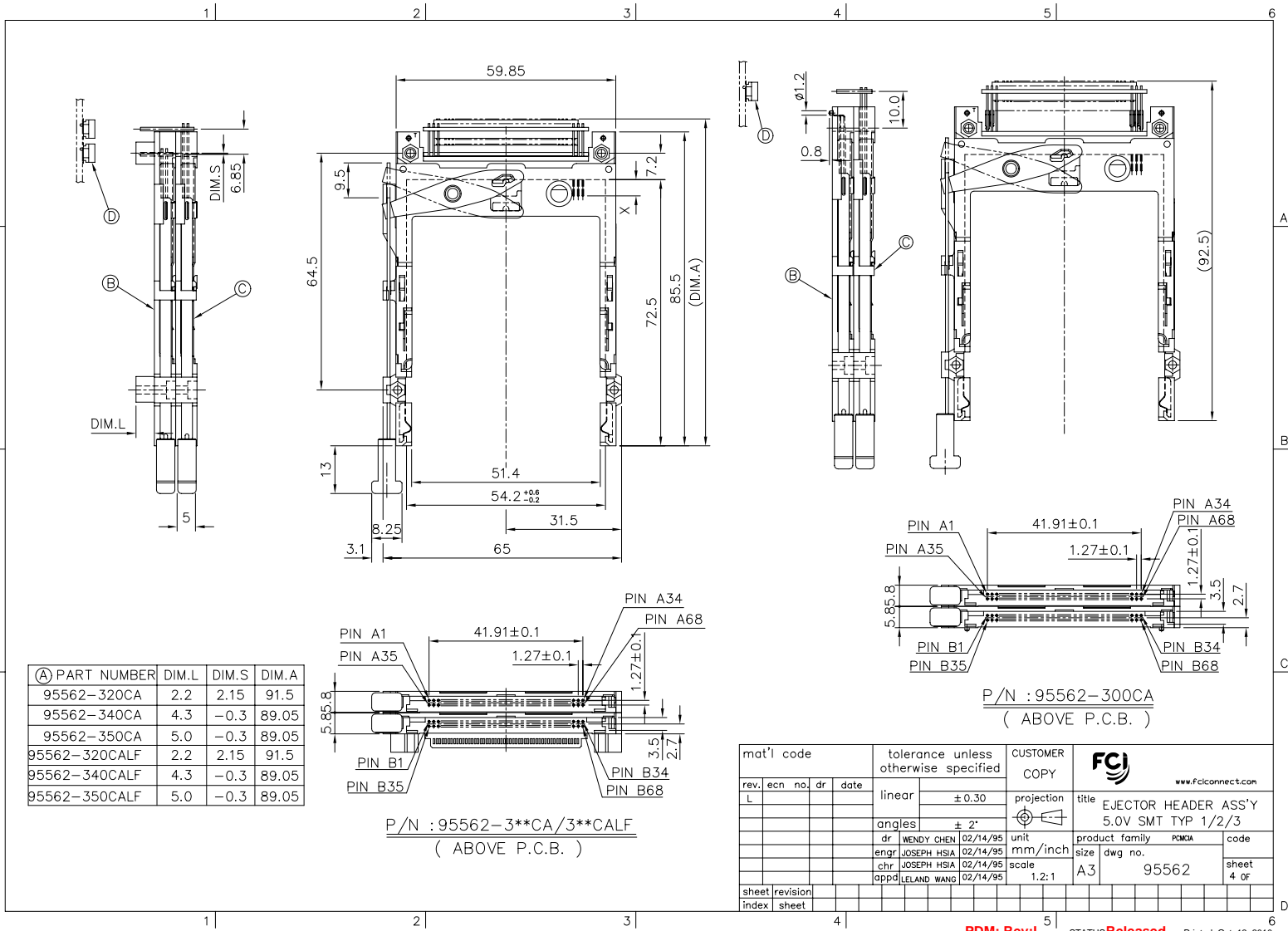

Tous droits strictement réservés. Reproduction ou communication à des tiers interdite sans autorisation écrite du propriétaire.  
 All rights strictly reserved. Reproduction or communication to third parties in any form or by any means is not permitted without written authority from the proprietor.  
 Copyright BERG ELECTRONICS by

All rights strictly reserved. Reproduction or issue to third parties in any form or by any means is not permitted without written authority from the proprietor.  
 Copyright BERG ELECTRONICS by

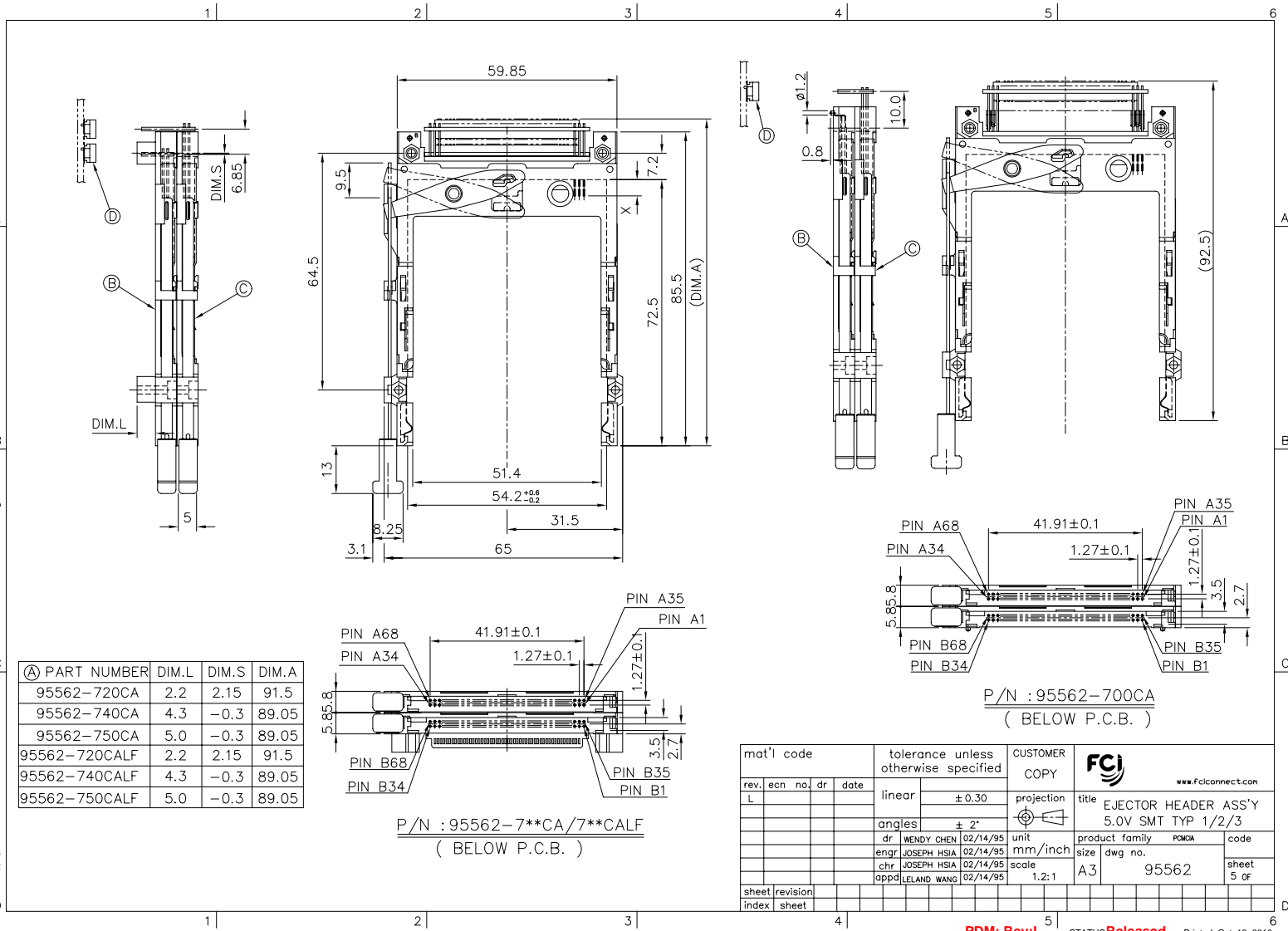

mat'l code	tolerance unless otherwise specified	CUSTOMER COPY	<b>FCJ</b> www.fcconnect.com
rev. L	linear ±0.30	projection	title EJECTOR HEADER ASS'Y 5.0V SMT TYP 1/2/3
ecn no.	angles ± 2°	unit mm/inch	product family PMGA
dr	dr WENDY CHEN 02/14/95	scale 1.2:1	size A3
engr	engr JOSEPH HSIA 02/14/95		dwg no. 95562
chr	chr JOSEPH HSIA 02/14/95		sheet 5 of
app'd	app'd LELAND WANG 02/14/95		
sheet index	revision sheet		

PDM: Rev:L STATUS Released Printed: Oct 12, 2010

Tous droits strictement réservés. Reproduction ou communication d'un tiers int  
 sous quelque forme que ce soit, sans autorisation écrite du propriétaire.  
 All rights strictly reserved. Reproduction or communication of a third party int  
 without written authority from the proprietor.  
 Copyright BERG ELECTRONICS BV

All rights strictly reserved. Reproduction or issue to third parties, in any for  
 whatever is not permitted without written authority from the proprietor.  
 Copyright BERG ELECTRONICS BV

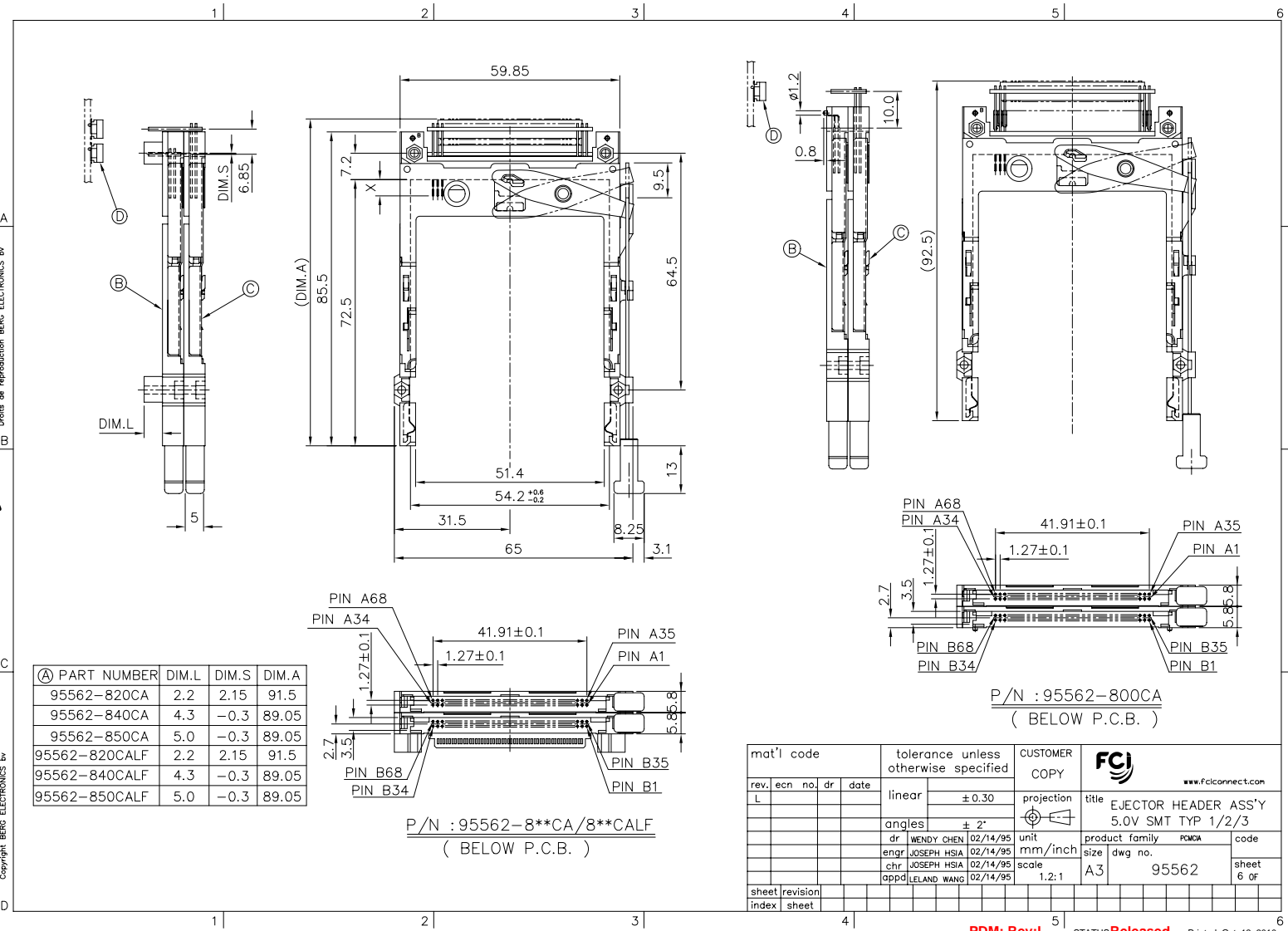

Ⓐ PART NUMBER	DIM.L	DIM.S	DIM.A
95562-820CA	2.2	2.15	91.5
95562-840CA	4.3	-0.3	89.05
95562-850CA	5.0	-0.3	89.05
95562-820CALF	2.2	2.15	91.5
95562-840CALF	4.3	-0.3	89.05
95562-850CALF	5.0	-0.3	89.05

P/N : 95562-8\*\*CA/8\*\*CALF  
 ( BELOW P.C.B. )

P/N : 95562-800CA  
 ( BELOW P.C.B. )

mat'l code	tolerance unless otherwise specified	CUSTOMER COPY	<b>FCJ</b>	www.fcjconnect.com
rev. ecn no. dr date	linear ±0.30	projection	title EJECTOR HEADER ASS'Y	
	angles ± 2'	unit	5.0V SMT TYP 1/2/3	
dr WENDY CHEN 02/14/95		mm/inch	product family	PCMCIA
enqr JOSEPH HSIA 02/14/95		scale	size	dwg no.
chr JOSEPH HSIA 02/14/95		1.2:1	A3	95562
oppd LELAND WANG 02/14/95				sheet 6 of
sheet index	revision sheet			

PDM: Rev:L STATUS Released Printed: Oct 12, 2010

Tous droits strictement réservés. Reproduction ou communication à des tiers sans autorisation écrite du propriétaire.  
 All rights strictly reserved. Reproduction or communication to third parties in any form without the written authority of the proprietor.  
 Copyright BERG ELECTRONICS BV

PRODUCT NO.	95562-*****
	95562-*****LF

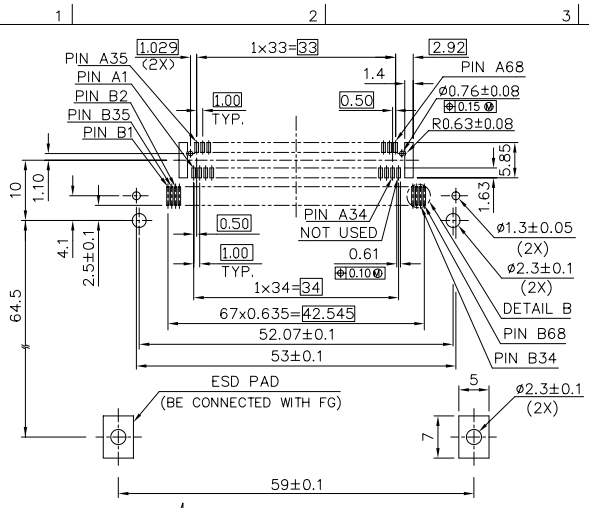

4 CARD INSERTION DIRECTION  
 RECOMMENDED P.C.B. LAYOUT 1 (MOUNTED SIDE)

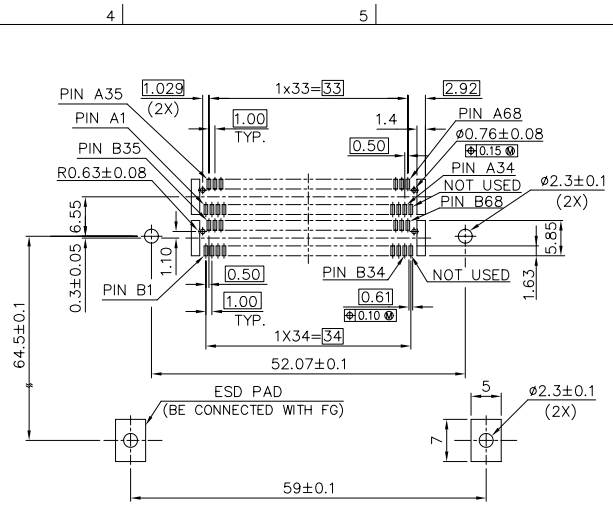

4 CARD INSERTION DIRECTION  
 RECOMMENDED P.C.B. LAYOUT 3 (MOUNTED SIDE)

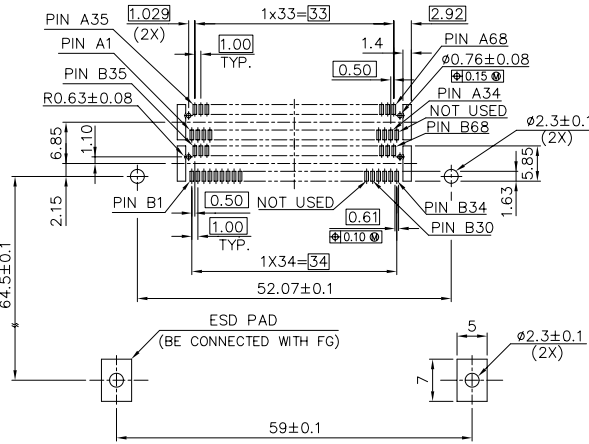

4 CARD INSERTION DIRECTION  
 RECOMMENDED P.C.B. LAYOUT 2 (MOUNTED SIDE)

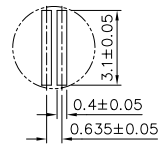

mat'l code		tolerance unless otherwise specified		CUSTOMER COPY		 www.fciconnect.com	
rev.	ecn no.	dr	date	linear	±0.30	projection	title
L				angles	± 2'		EJECTOR HEADER ASS'Y 6.8POS.SMT TYPE 1/2/3
				dr	WENDY CHEN 02/08/95	unit	product family
				enqr	JOSEPH HSIA 02/08/95	mm/inch	POMGA
				chr	JOSEPH HSIA 02/08/95	scale	size
				oppd	LELAND WANG 02/08/95	1.5:1	dwg no.
							A3
sheet	revision						product family
index	sheet						POMGA
							code
							95562
							size
							A3
							dwg no.
							95562
							sheet
							7 of

PDM: Rev:L STATUS Released Printed: Oct 12, 2010

Tous droits strictement réservés. Reproduction ou communication de ces plans int.  
 sous quelque forme que ce soit, sans autorisation écrite du propriétaire.  
 All rights strictly reserved. Reproduction or communication of these plans int.  
 in any form, without written authority from the proprietor.  
 Copyright BERG ELECTRONICS INC.

All rights strictly reserved. Reproduction or issue to third parties in any form  
 whatsoever is not permitted without written authority from the proprietor.  
 Copyright BERG ELECTRONICS INC.

PRODUCT NO.	
95562-*****	
95562-*****LF	

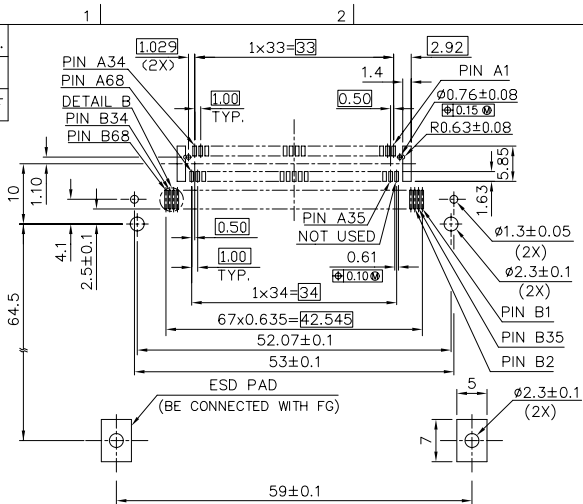

4 CARD INSERTION DIRECTION  
 RECOMMENDED P.C.B. LAYOUT 4 (MOUNTED SIDE)

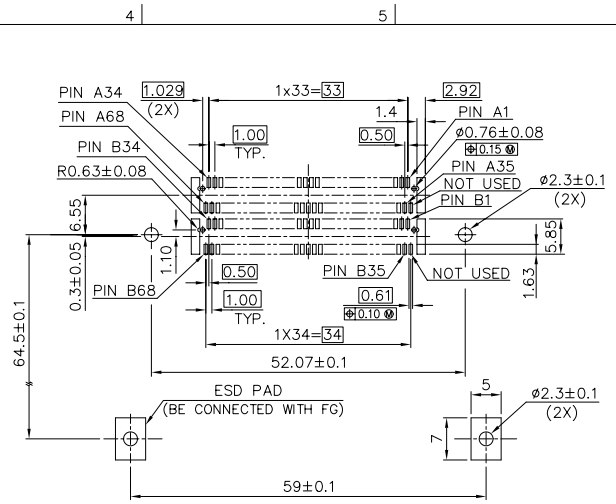

4 CARD INSERTION DIRECTION  
 RECOMMENDED P.C.B. LAYOUT 6 (MOUNTED SIDE)

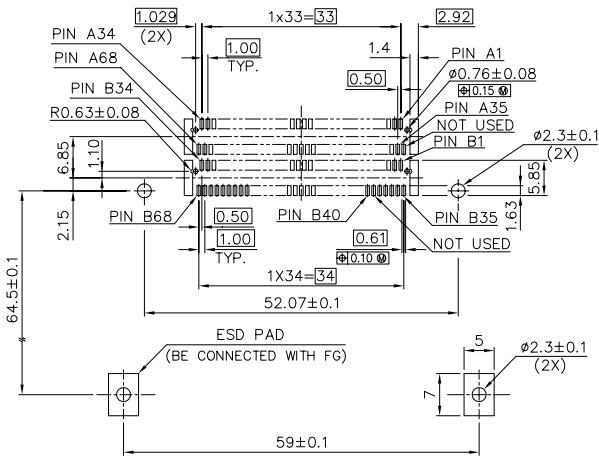

4 CARD INSERTION DIRECTION  
 RECOMMENDED P.C.B. LAYOUT 5 (MOUNTED SIDE)

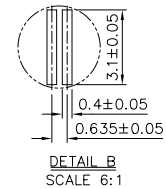

mat'l code		tolerance unless otherwise specified		CUSTOMER COPY		FCI		www.fciconnect.com	
rev.	ecn no.	dr	date	linear	±0.30	projection	title EJECTOR HEADER ASS'Y		
L				angles	± 2°		68POS.SMT TYPE 1/2/3		
				dr	WENDY CHEN	02/08/95	unit	product family	POMGA
				engr	JOSEPH HSIA	02/08/95	mm/inch	size	dwg no.
				chr	JOSEPH HSIA	02/08/95	scale	A3	95562
				pppd	LELAND WANG	02/08/95	1.5:1		8 of
sheet	revision								
index	sheet								



Tous droits strictement réservés. Reproduction ou communication à des tiers sans autorisation écrite du propriétaire.  
 All rights strictly reserved. Reproduction or issue to third parties in any form without the written authority from the proprietor.  
 Property of © BERG ELECTRONICS. Copyright BERG ELECTRONICS by

PART NUMBER DESCRIPTION :

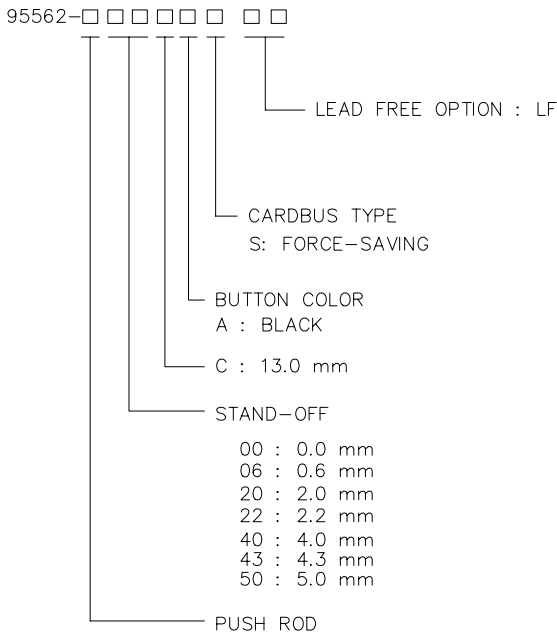

TOP MOUNT	BOTTOM MOUNT
0 : RIGHT-LEFT	5 : RIGHT-LEFT
1 : LEFT-RIGHT	6 : LEFT-RIGHT
2 : RIGHT-RIGHT	7 : RIGHT-RIGHT
3 : LEFT-LEFT	8 : LEFT-LEFT

NOTES:

- 8mm MIN. CARD EJECT.
- EJECT TRAVEL: 9.5mm
- MATERIAL
  - HEADER ASS'Y :
    - PLASTIC : HOUSING ...LCP UL94V-0 BLACK
    - PIN : COPPER ALLOY
    - PCB : FR4
  - EJECT MECHANISM ASS'Y :
    - PLASTIC : GUIDE: POLYPHTHARAMID UL94V-0 BLACK
    - : BUTTON: POLYPHTHARAMID UL94V-0 BLACK
    - PLATE : STAINLESS
    - EMI CONTACT: PHOSPHOR BRONZE
  - RECEPTACLE :
    - PLASTIC : LCP 94V-0, NATURAL.
    - PIN: BeCu
- FINISH (PIN)
  - UNDER PLATING : 0.5µm MIN. Ni
  - CONTACT AREA : 0.1µm MIN. GOLD OVER
  - 0.5µm MIN. Pd-Ni
  - SOLDER TAIL : 2.5µm MIN. Sn-Pb(FOR TIN LEAD OPTION)
  - : 2.5µm MIN. PURE TIN (FOR LEAD FREE OPTION)
- PUSH ROD LOCATION AND P.C.B. SIDE ARE AS APPEARS INSTALLED.
- DIM "X"
 

4.25±0.1	3.5±0.1	5.0±0.1
OTHERS	36,67	1,17,34,35,51,68
- DO NOT TOUCH AND KEEP CLEAN THE SURFACES OF PCB OF HEADER.
- IF LEAD FREE P.N.THE HOUSING WILL WITHSTAND EXPOSURE TO 260°C PEAK TEMPERATURE FOR 10 SECONDS IN A WAVE SOLDER APPLICATION WITH A 1.00MM MINIMUM THICK CIRCUIT BOARD.
- IF LEAD FREE P/N.THE PRODUCT MEETS EUROPEAN UNION DIRECTIVES AND OTHER COUNTRY REGULATIONS AS DESCRIBED IN GS-22-008
- LEAD FREE P/N PACKAGING MEETS GS-14-920 SPECIFICATION

mat'l code		tolerance unless otherwise specified		CUSTOMER COPY		 www.fcjconnect.com	
rev.	ecn no.	dr	date	linear	±0.30	projection	title
L				angles	± 2°		EJECTOR HEADER ASS'Y
				dr	WENDY CHEN 02/29/00	unit	68POS. SMT, TYPE 1/2/3
				enrg	JOSEPH HSIAO 02/29/00	mm/inch	product family
				chr	JOSEPH HSIAO 02/29/00	scale	PKGA
				appd	LELAND WANG 02/29/00	1:1	code
sheet	revision						size
index	sheet						dwg no.
							95562
							sheet
							9 of