

DESCRIPTION: ABOVE AND BELOW P.C.B., DECK IS AS VIEWED BY USER.

PRODUCT NO. 72306-XXX	STAND-OFF HEIGHT DIM L	Ⓐ CLOSEST TO P.C.B. HEADER ASSY 72305-XXX	Ⓑ FARTHEST FROM P.C.B. HEADER ASSY 72305-XXX	Ⓒ MATING RECEPTACLE	MOUNTING STYLE TO PCB
000	0.0	000	005	100 POSITION (2x50) 0.8mm RECEPTACLE PART NO. 73277-101000 ORDER SEPARATELY	
020	2.2	020	025		
040	4.3	040	045		
050	5.0	050	055		
520	2.2	520	525		
540	4.3	540	545	100 POSITION (2x50) 0.8mm RECEPTACLE PART NO. 73277-101000LF ORDER SEPARATELY	
550	5.0	550	555		
000LF	0.0	000LF	005LF		
020LF	2.2	020LF	025LF		
040LF	4.3	040LF	045LF		
050LF	5.0	050LF	055LF		
520LF	2.2	520LF	525LF		
540LF	4.3	540LF	545LF		
550LF	5.0	550LF	555LF		

NOTE:
1. SEE 72305 FOR SINGLE DECK APPLICATIONS

ORDERING INFORMATION
ORDER:
1. Ⓐ DECK CLOSEST TO P.C.B.
2. Ⓑ DECK FARTHEST FROM P.C.B.
3. Ⓒ 2 EACH MATING RECEPTACLES

mat'l. code		tolerances unless otherwise specified		CUSTOMER COPY	FCI Electronics www.fciconnect.com	
ltr	ecr no	dr	date	linear	projection	title
A	V61041	RHG	9/9/96	.X±.3		CARDBUS DOUBLE DECK ASS'Y SMT TYPE 123
B	V70392	RHG	6/18/97	.XX±.13		
C	V81734	DAI	10/6/98	.XXX±.051	MM	product family MCS
D	V02257	TFG	11/3/00	0° ±2°		
E	N05-0165	WB	06/15/06		scale	dwg no
				chr	1:1	A4
				enrg		72306
				D.BRANN		sheet
				9/9/96		1 of 9
				D.BRANN		
				9/9/96		
sheet	revision	E	E	E	E	E
index	sheet	1	2	3	4	5

ACAD

PDM: Rev:E

STATUS: Released

Printed: Oct 12, 2010

Tous droits strictement reserves. Reproduction ou communication a des tiers interdite sous quelque forme que ce soit sans autorisation écrite du propriétaire. Property of FCI. Copyright FCI.

All rights strictly reserved. Reproduction or issue to third parties in any form whatever is not permitted without written authority from the proprietor. Property of FCI. Copyright FCI.

Tous droits strictement réservés. Reproduction ou communication à des tiers interdite sous quelque forme que ce soit sans autorisation écrite du propriétaire. Propriété de c FCI. Droits de reproduction FCI.

All rights strictly reserved. Reproduction or issue to third parties in any form whatever is not permitted without written authority from the proprietor. Property of FCI. Copyright FCI.

FCI

PRODUCT NUMBER
72306-***/***/LF

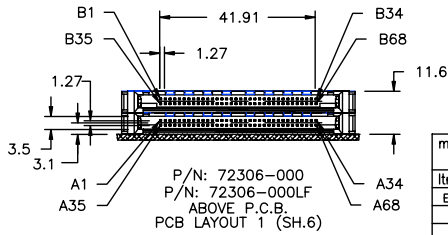
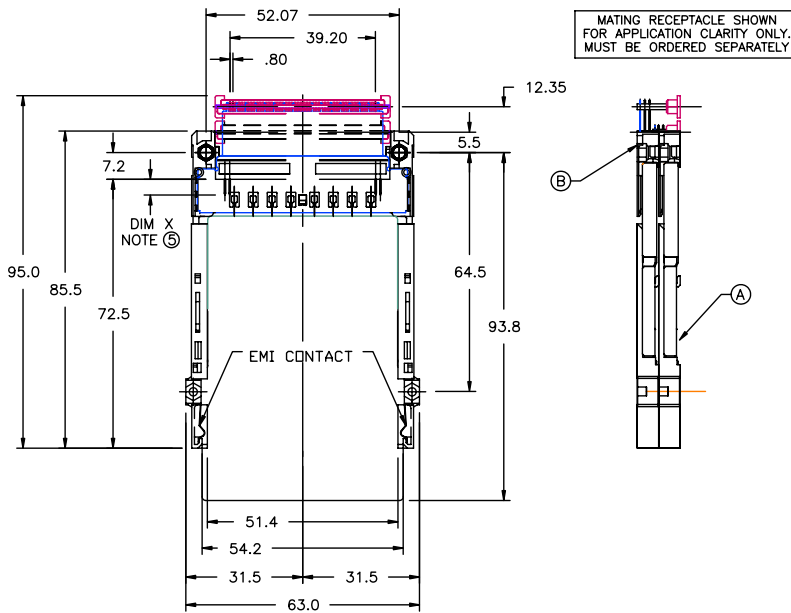

mat'l. code		tolerances unless otherwise specified		CUSTOMER COPY	FCI Electronics www.fciconnect.com	
ltr	ecn no	dr	date	linear	projection	title
E						CARBUS DOUBLE DECK ASS'Y SMT TYPE 123
				angles	MM	product family
				dr		MCS
				enrg		size
				chr		dwg no
				appd		A4
					scale	72306
					1:1	sheet
sheet index	revision sheet					2 of

ACAD

PDM: Rev:E

STATUS Released
cage code 26
Printed: Oct 12, 2010

Tous droits strictement réservés. Reproduction ou communication à des tiers
interdite sous quelque forme que ce soit sans autorisation écrite du propriétaire.
Propriété de c FCI. Droits de reproduction FCI.

All rights strictly reserved. Reproduction or issue to third parties in any
form whatever is not permitted without written authority from the proprietor.
Property of FCI. Copyright FCI.

PRODUCT NUMBER
72306-***/**LF

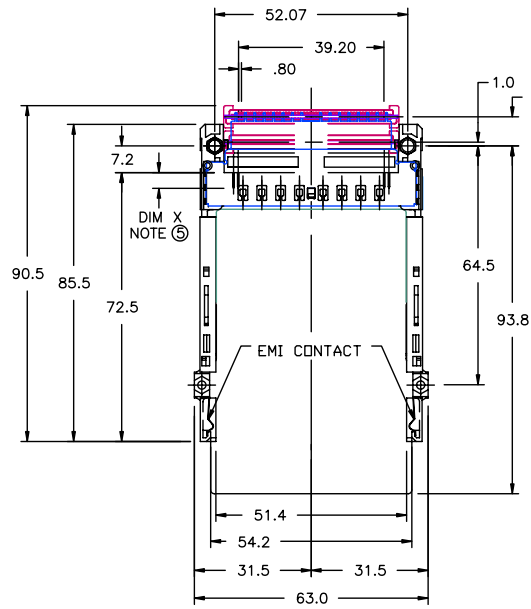

MATING RECEPTACLE SHOWN
FOR APPLICATION CLARITY ONLY.
MUST BE ORDERED SEPARATELY

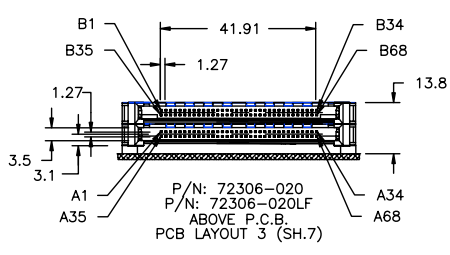
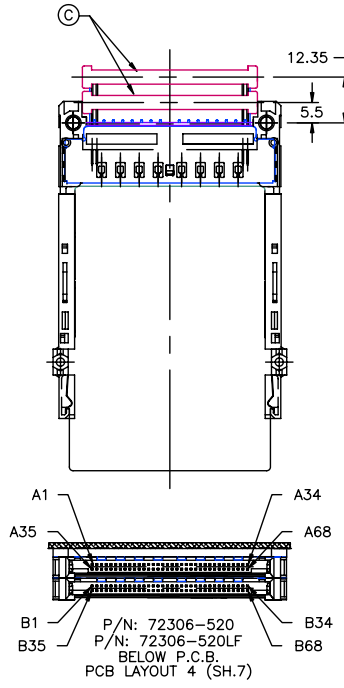
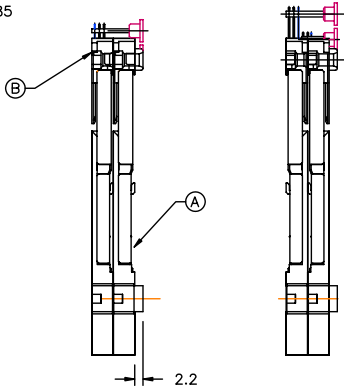

mat'l. code		tolerances unless otherwise specified		CUSTOMER COPY		Electronics www.fciconnect.com	
ltr	ecn no	dr	date	linear	.XX±.13	projection	title
E				angles	.XXX±.051		CARDBUS DOUBLE DECK ASS'Y SMT TYPE 123
				dr	0° ±2'		product family
				engr	R.GRAPE 9/9/96	size	dwg no
				chr	D.BRANN 9/9/96	scale	A4
				appd	D.BRANN 9/9/96	1:1	72306
sheet	revision						
index	sheet						

ACAD PDM: Rev:E STATUS Released 2.6 Printed: Oct 12, 2010

Tous droits strictement réservés. Reproduction ou communication à des tiers
interdite sous quelque forme que ce soit sans autorisation écrite du propriétaire.
Propriété de c FCI. Droits de reproduction FCI.

All rights strictly reserved. Reproduction or issue to third parties in any
form whatever is not permitted without written authority from the proprietor.
Property of FCI. Copyright FCI.

PRODUCT NUMBER
72306-***/**LF

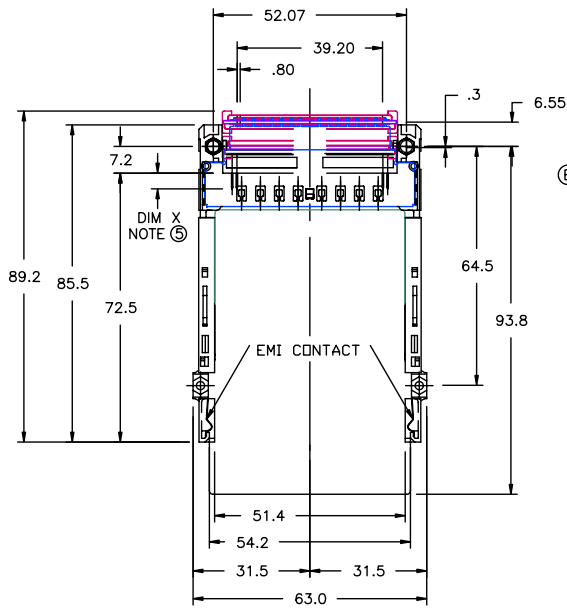

MATING RECEPTACLE SHOWN
FOR APPLICATION CLARITY ONLY.
MUST BE ORDERED SEPARATELY

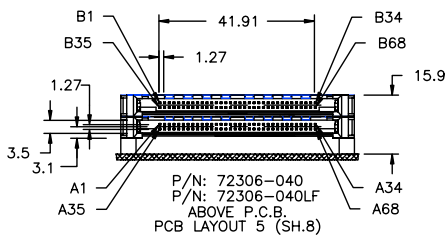
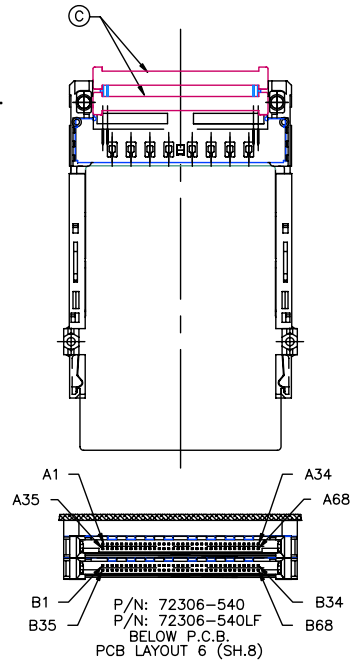
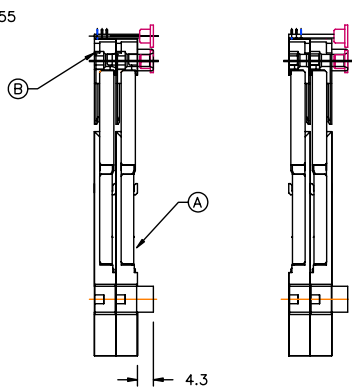

mat'l. code		tolerances unless otherwise specified		CUSTOMER COPY		Electronics www.fciconnect.com	
ltr	ecn no	dr	date	linear	.XX±.13	projection	title
E				angles	.XXX±.051		CARDBUS DOUBLE DECK ASS'Y SMT TYPE 123
				dr	R.GRAPE 9/9/96		product family MCS
				engr	D.BRANN 9/9/96	MM	size dwg no
				chr	D.BRANN 9/9/96	1:1	A4 72306
				appd	D.BRANN 9/9/96		code
sheet	revision						4 of
index	sheet						

ACAD

PDM: Rev:E

STATUS Released 26 Printed: Oct 12, 2014

Tous droits strictement réservés. Reproduction ou communication à des tiers
interdite sous quelque forme que ce soit sans autorisation écrite du propriétaire.
Propriété de c FCI. Droits de reproduction FCI.

All rights strictly reserved. Reproduction or issue to third parties in any
form whatever is not permitted without written authority from the proprietor.
Property of FCI. Copyright FCI.

PRODUCT NUMBER
72306-***/**LF

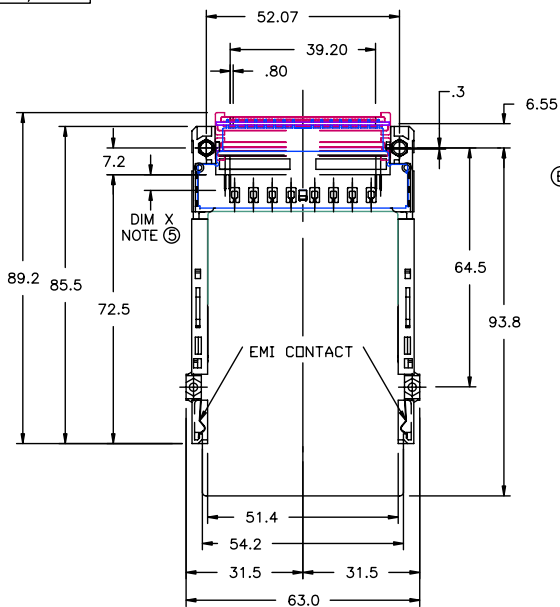

MATING RECEPTACLE SHOWN
FOR APPLICATION CLARITY ONLY.
MUST BE ORDERED SEPARATELY

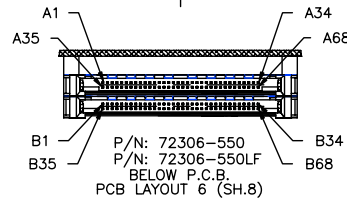
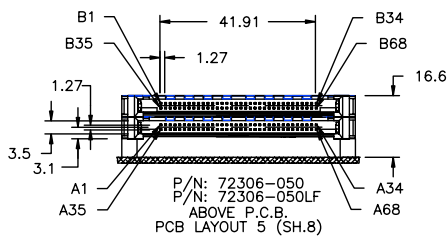
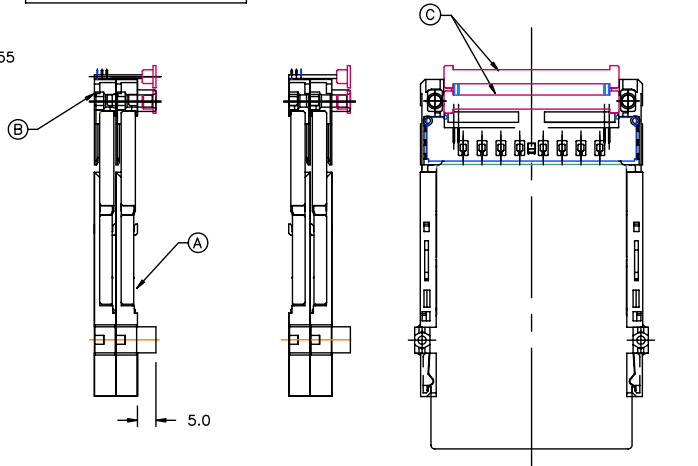

mat'l. code		tolerances unless otherwise specified		CUSTOMER COPY		Electronics www.fciconnect.com	
ltr	ecn no	dr	date	linear	.XX±.13	projection	title
E				angles	.XXX±.051		CARDBUS DOUBLE DECK ASS'Y SMT TYPE 123
				dr	R.GRAPE 9/9/96		product family MCS
				engr	D.BRANN 9/9/96	MM	size dwg no
				chr	D.BRANN 9/9/96	1:1	A4 72306
				appd	D.BRANN 9/9/96		sheet 5 of
sheet index	revision sheet						cage code

ACAD

PDM: Rev: E

STATUS Released 2.6 Printed: Oct 12, 2014

1 | 2

3 |

4

1 | 2

3

4

P.C.B. LAYOUT FOR 0mm STANDOFF

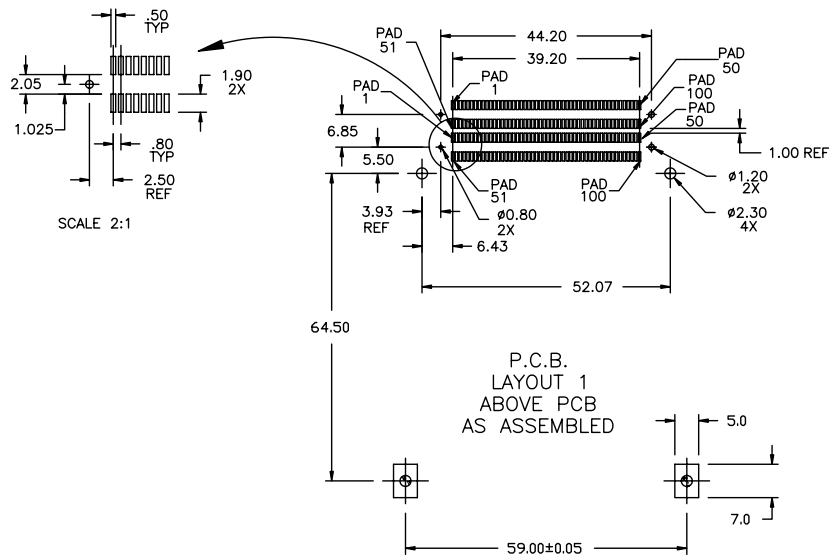

P.C.B.
LAYOUT 1
ABOVE PCB
AS ASSEMBLED

mat'l. code				tolerances unless otherwise specified		CUSTOMER COPY		 www.fciconnect.com	
ltr	ecn no	dr	date	linear	.X±.3	projection	title		
E					.XX±.13	 MM	CARDBUS DOUBLE DECK		
				angles	.XXX±.051		ASS'Y SMT TYPE 123		
					0° ±2'	scale	product family	MCS	code
				dr	R.GRAPE 9/9/96	1:1	size	dwg no	sheet
				engr	D.BRANN 9/9/96		A4	72306	6 of
				chr	D.BRANN 9/9/96				
				appd	D.BRANN 9/9/96				
sheet index	revision sheet								

ACAD PDM: Rev:E STATUS Released 2.6 Printed: Oct 12, 2014

Tous droits strictement reserves. Reproduction ou communication a des tiers
 interdite sous quelque forme que ce soit sans autorisation écrite du propriétaire.
 Propriete de c FCI. Droits de reproduction FCI.

All rights strictly reserved. Reproduction or issue to third parties in any
 form whatever is not permitted without written authority from the proprietor.
 Property of FCI. Copyright FCI.

Tous droits strictement réservés. Reproduction ou communication à des tiers
interdite sous quelque forme que ce soit sans autorisation écrite du propriétaire.
Propriété de FCI. Droits de reproduction FCI.

All rights strictly reserved. Reproduction or issue to third parties in any
form whatever is not permitted without written authority from the proprietor.
Property of FCI. Copyright FCI.

P.C.B. LAYOUT FOR 2.2mm STANDOFF

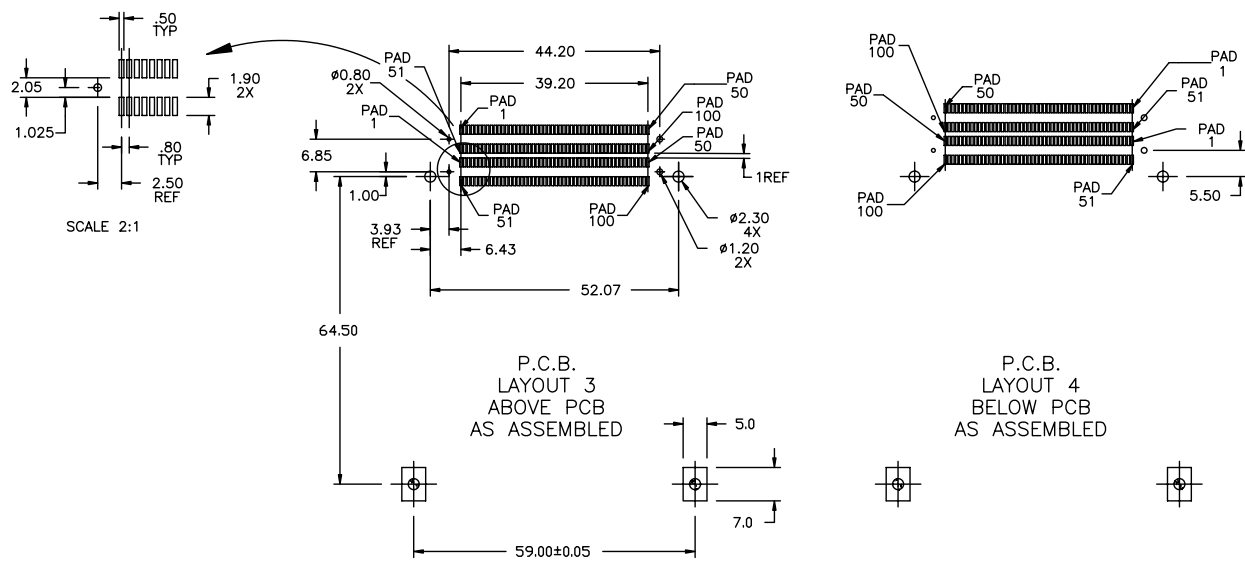

mat'l. code		tolerances unless otherwise specified		CUSTOMER COPY	 FCI www.fclconnect.com			
ltr	ecn no	dr	date	linear	projection	title		
E				.X±.3		CARDBUS DOUBLE DECK ASS'Y SMT TYPE 123		
				.XX±.13		product family	MCS	
				.XXX±.051	← MM →	size	dwg no	
				angles	scale	A4	72306	
				0° ±2°	1:1		sheet 7 of	
				dr	R.GRAPE	9/9/96	code	
				engr	D.BRANN	9/9/96		
				chr	D.BRANN	9/9/96		
				appd	D.BRANN	9/9/96		
sheet index	revision sheet							

P.C.B. LAYOUT FOR 4.3 AND 5.0mm STANDOFFS

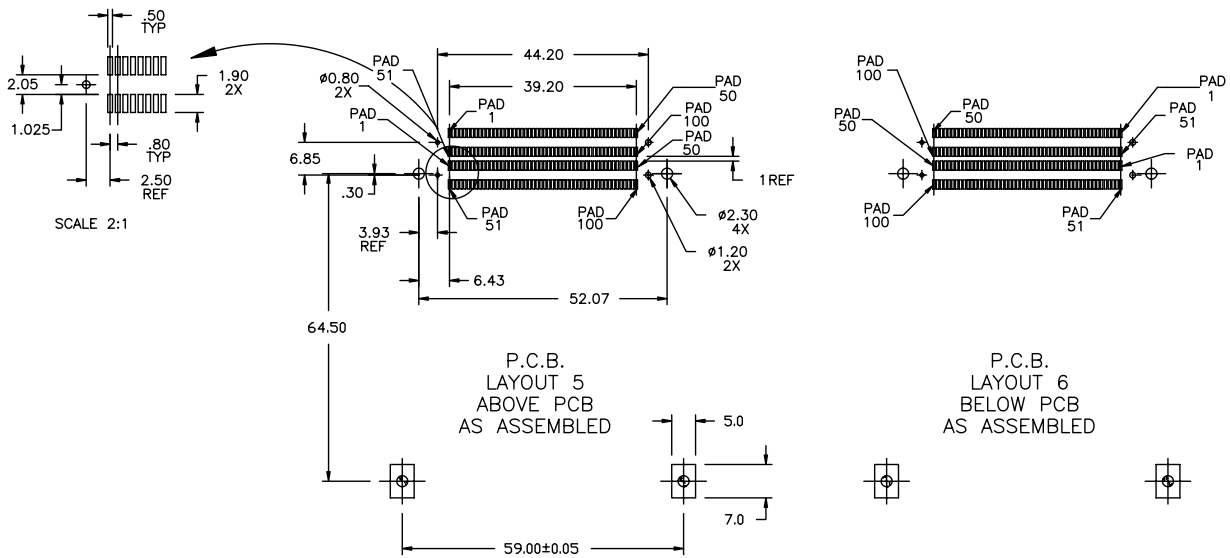

mat'l. code		tolerances unless otherwise specified		CUSTOMER COPY		 FCI Electronics www.fciconnect.com	
ltr	ecn no	dr	date	linear	.XX±.13	projection	title
E				angles	.XXX±.051		CARDBUS DOUBLE DECK ASS'Y SMT TYPE 123
				dr	0° ±2'		product family
				enrg	R.GRAPE 9/9/96	MM	MCS
				chr	D.BRANN 9/9/96	scale	size
				appd	D.BRANN 9/9/96	1:1	dwg no
sheet	revision						A4
index	sheet						72306
							code
							8 of

ACAD PDM: Rev:E STATUS Released 2.6 Printed: Oct 12, 2014

Tous droits strictement réservés. Reproduction ou communication à des tiers
 interdite sous quelque forme que ce soit sans autorisation écrite du propriétaire.
 Propriété de c FCI. Droits de reproduction FCI.

All rights strictly reserved. Reproduction or issue to third parties in any
 form whatever is not permitted without written authority from the proprietor.
 Property of FCI. Copyright FCI.

Tous droits strictement réservés. Reproduction ou communication à des tiers interdite sous quelque forme que ce soit sans autorisation écrite du propriétaire. Propriété de c FCI. Droits de reproduction FCI.

All rights strictly reserved. Reproduction or issue to third parties in any form whatever is not permitted without written authority from the proprietor. Property of FCI. Copyright FCI.

HEADER PINOUT	TYPE	BTB 100 POS RECEPTACLE	HEADER PINOUT	TYPE	BTB 100 POS RECEPTACLE	SHIELD PINOUT	TYPE	BTB 100 POS RECEPTACLE
1	GND	1	35	GND	51	1	GND	4 & 54
2	SIG	2	36	DET	52	2	GND	7 & 57
3	SIG	3	37	SIG	53	3	GND	10 & 60
4	SIG	5	38	SIG	55	4	GND	13 & 63
5	SIG	6	39	SIG	56	5	GND	16 & 66
6	SIG	8	40	SIG	58	6	GND	19 & 69
7	SIG	9	41	SIG	59	7	GND	22 & 72
8	SIG	11	42	SIG	61	8	GND	25 & 75
9	SIG	12	43	SIG	62	9	GND	26 & 76
10	SIG	14	44	SIG	64	10	GND	29 & 79
11	SIG	15	45	SIG	65	11	GND	32 & 82
12	SIG	17	46	SIG	67	12	GND	35 & 85
13	SIG	18	47	SIG	68	13	GND	38 & 88
14	SIG	20	48	SIG	70	14	GND	41 & 91
15	SIG	21	49	SIG	71	15	GND	44 & 94
16	SIG	23	50	SIG	73	16	GND	47 & 97
17	PWR	24	51	PWR	74			
18	SIG	27	52	SIG	77			
19	SIG	28	53	SIG	78			
20	SIG	30	54	SIG	80			
21	SIG	31	55	SIG	81			
22	SIG	33	56	SIG	83			
23	SIG	34	57	SIG	84			
24	SIG	36	58	SIG	86			
25	SIG	37	59	SIG	87			
26	SIG	39	60	SIG	89			
27	SIG	40	61	SIG	90			
28	SIG	42	62	SIG	92			
29	SIG	43	63	SIG	93			
30	SIG	45	64	SIG	95			
31	SIG	46	65	SIG	96			
32	SIG	48	66	SIG	98			
33	SIG	49	67	DET	99			
34	GND	50	68	GND	100			

NOTES:

- ORDER MATING RECEPTACLES SEPARATELY.
- RECOMMENDED SCREW TORQUE: 1.0 TO 1.5 MAX in-lbs. (1.2-1.7 cm-kgs).
RECOMMENDED HOLD-DOWN - 2mm SCREWS (95121) AND HEX NUTS (92869).
- MATERIAL:
 - HEADER ASSY:
PLASTIC HOUSING: LCP UL94V-0 BLACK - ABOVE PCB
LCP UL94V-0 BLACK - BELOW PCB
PIN: PHOSPHOR BRONZE
PCB: FR4
 - MECHANISM ASSY:
PLASTIC GUIDE: POLYPHTHARAMID UL94V-0 BLACK
COVER PLATE: STAINLESS STEEL
EMI CONTACT: PHOSPHOR BRONZE
 - .8 BTB RECEPTACLE (73277-101000):
PLASTIC: LCP 94V-0 BLACK
CONTACT: BeCu
- FINISH (PIN)
UNDER PLATING: 0.5um Ni
CONTACT AREA: 0.1um GOLD OVER
0.5um Pd-Ni
SOLDER TAIL: 2.5um Sn-Pb
2.5um PURE Sn (FOR -***LF)

⑤ DIM "X"

4.25±0.1	3.5±0.1	5.0±0.1
OTHERS	36,67	1,17,34,35,51,68

- IF LEAD FREE P.N.THE HOUSING WILL WITHSTAND EXPOSURE TO 260°C PEAK TEMPERATURE FOR 10 SECONDS IN A WAVE SOLDER APPLICATION WITH A 1.00MM MINIMUM THICK CIRCUIT BOARD.
- IF LEAD FREE P/N.THE PRODUCT MEETS EUROPEAN UNION DIRECTIVES AND OTHER COUNTRY REGULATIONS AS DESCRIBED IN GS-22-008
- LEAD FREE P/N PACKAGING MEETS GS-14-920 SPECIFICATION

mat'l. code		tolerances unless otherwise specified		CUSTOMER COPY		 www.fciconnect.com	
ltr	ecn no	dr	date	linear	projection	title	
E				.X±.3	MM	CARDBUS DOUBLE DECK	
				.XX±.13		ASS'Y SMT TYPE 123	
				.XXX±.051		product family	code
				0° ±2'		MCS	-
				dr R.GRAPE 9/9/96		size	dwg no
				enrg D.BRANN 9/9/96		A4	72306
				chr D.BRANN 9/9/96	scale	1:1	sheet
				appd D.BRANN 9/9/96			9 of
sheet index	revision						
	sheet						