

Tous droits strictement réservés. Reproduction ou communication a des tiers interdite sous quelque forme que ce soit sans autorisation écrite du propriétaire. Propriété de c FCI. Droits de reproduction FCI.

All rights strictly reserved. Reproduction or issue to third parties in any form whatever is not permitted without written authority from the proprietor. Property of FCI. Copyright FCI.

PRODUCT NO.
73408-003
73408-003LF

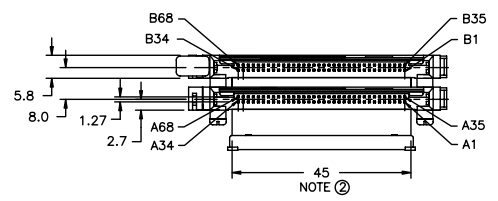
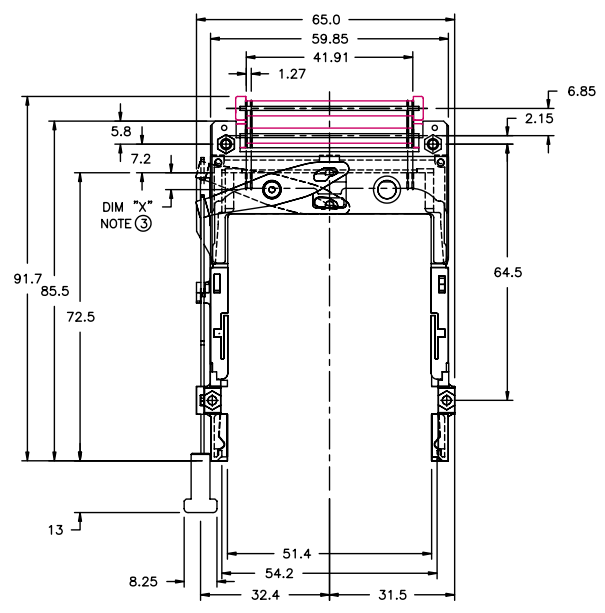
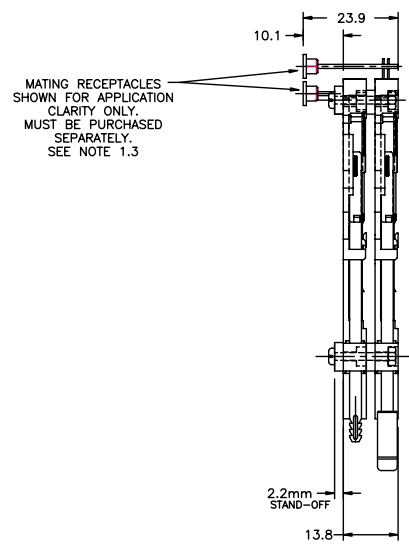

NOTE:
 1. APPLICATION IS BELOW P.C.B. MOUNT
 ② BOARD WIDTH - 45mm MAX
 EXAMPLE:

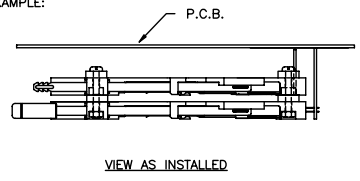

mat'l. code		tolerances unless otherwise specified		CUSTOMER COPY		 www.fciconnect.com		
ltr	ecn no	dr	date	linear	projection	title		
A	V70358	RHG	3/10/97	.X±.3	 MM scale 1:1	DOUBLE DECK VTB HEADER ASSEMBLY		
B	V71625	RHG	11/25/97	.XX±.13		product family	MCS	code
C	V12254	TFG	9/26/01	.XXX±.051		size	dwg no	
D	N05-0196	WB	07/05/05	0° ±2'		A4	73408	
				dr R.GRAPE 3/10/97				
				enrg D.BRANN 3/10/97				
				chr D.BRANN 3/10/97				
				appd D.BRANN 3/10/97				
sheet index	revision sheet	D	D					sheet 1 of 2
		1	2					

