

Tous droits strictement réservés. Reproduction ou communication à des tiers
interdite sous quelque forme que ce soit sans autorisation écrite du propriétaire.
Property of FCI. Prohibits de reproduction FCI.

All rights strictly reserved. Reproduction or issue to third parties in any
form whatever is not permitted without written authority from the proprietor.
Property of FCI. Copyright FCI.

PRODUCT NUMBER
94050-XXXX/XXXXLF

PCMCIA COMPONENTS
DOUBLE DECK 5V EJECT HEADER ASSEMBLY
65mm WIDE, 8mm CARD TRAVEL

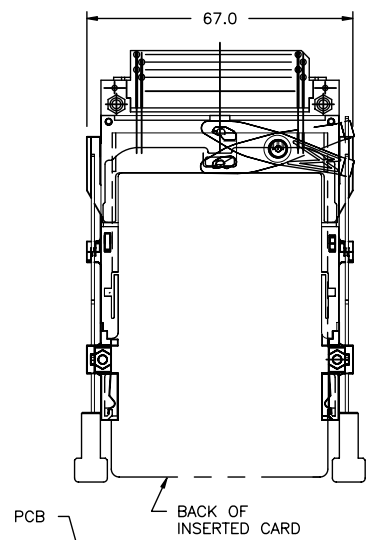

LEFT/RIGHT PUSH ROD
RT. ANGLE SOLDER TAIL
BELOW PCB SIDE
P/N: 94050-600CA/600CALF

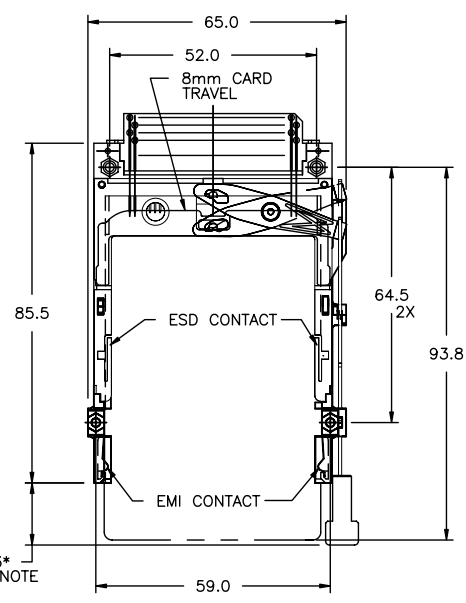

RIGHT/RIGHT PUSH ROD
RT. ANGLE SOLDER TAIL
ABOVE PCB SIDE
P/N: 94050-200CA/200CALF

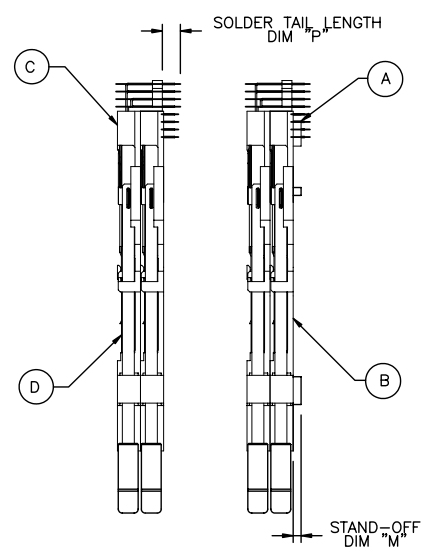

STAND-OFF
RT. ANGLE
SOLDER TAIL

NOTE: * 21 FOR 94050-220FA/220FALF

CONFIDENTIAL

| mat'l. code | | tolerances unless otherwise specified | | CUSTOMER COPY | |
|-------------|----------------|---------------------------------------|----------|---------------|------------|
| ltr | ecn no | dr | date | linear | projection |
| A | V41863 | RDS | 12/7/94 | .X±.3 | MM |
| B | V50126 | MSC | 2/3/95 | .XX±.13 | MM |
| C | V50254 | MSC | 3/1/95 | .XXX±.051 | MM |
| D | V60578 | RHG | 4/9/96 | 0° ±2° | MM |
| E | V02234 | RJR | 10/10/00 | | MM |
| F | V12707 | RGD | 11/15/01 | | MM |
| G | N05-0045 | WB | 02/18/05 | | MM |
| sheet index | revision sheet | G | G | G | |

| | | |
|----------------|----------------------------------|--------|
| product family | title | code |
| MCS | DOUBLE DECK 5V EJECT HEADER ASSY | |
| size | dwg no | sheet |
| A4 | 94050 | 1 of 3 |

1 | 2

3 |

4

ACAD

PDM: Rev:G

STATUS: Released

Printed: Oct 12, 2010

All rights strictly reserved. Reproduction or issue to third parties in any form and by any means, without written authority from the proprietor. Property of FCI. Copyright FCI.

Tous droits strictement réservés. Reproduction ou communication à des tiers sous quelque forme que ce soit sans autorisation écrite du propriétaire. Propriété de FCI. Droits de reproduction FCI.

1 | 2

3

4

DESCRIPTION: ABOVE AND BELOW P.C.B., DECK AND PUSH-ROD LOCATION ARE AS VIEW BY USER.

| PRODUCT NO. 94050-XXXX | STAND OFF DIM "M" (mm) | UPPER DECK | | LOWER DECK | | DIM "P" (mm) | HEADER COLOR | MOUNTING STYLE TO PCB & PUSH ROD SIDE |
|---------------------------|------------------------------|-------------------------------|---------------------------|-------------------------------|---------------------------|-----------------|-----------------|---|
| | | MECHANISM 95079- XXXX ④ | HEADER 92140- XXX ③ | MECHANISM 95079- XXXX ⑥ | HEADER 92140- XXX ⑤ | | | |
| 000CA | 0 | 00CA | 005 | 10CA | 000 | 2.8 | BLACK | |
| 020CA | 2 | 00CA | 045 | 12CA | 040 | 2.5 | BLACK | |
| 000CALF | 0 | 00CA | 005LF | 10CA | 000LF | 2.8 | BLACK | |
| 020CALF | 2 | 00CA | 045LF | 12CA | 040LF | 2.5 | BLACK | |
| 100CA | 0 | 10CA | 005 | 00CA | 000 | 2.8 | BLACK | |
| 120CA | 2 | 10CA | 045 | 02CA | 040 | 2.5 | BLACK | |
| 100CALF | 0 | 10CA | 005LF | 00CA | 000LF | 2.8 | BLACK | |
| 120CALF | 2 | 10CA | 045LF | 02CA | 040LF | 2.5 | BLACK | |
| 200CA | 0 | 00CA | 005 | 00CA | 000 | 2.8 | BLACK | |
| 220CA | 2 | 00CA | 045 | 02CA | 040 | 2.5 | BLACK | |
| 220FA | 2 | 00FA | 045 | 02FA | 040 | 2.5 | BLACK | |
| 200CALF | 0 | 00CA | 005LF | 00CA | 000LF | 2.8 | BLACK | |
| 220CALF | 2 | 00CA | 045LF | 02CA | 040LF | 2.5 | BLACK | |
| 220FALF | 2 | 00FA | 045LF | 02FA | 040LF | 2.5 | BLACK | |
| 300CA | 0 | 10CA | 005 | 10CA | 000 | 2.8 | BLACK | |
| 320CA | 2 | 10CA | 045 | 12CA | 040 | 2.5 | BLACK | |
| 300CALF | 0 | 10CA | 005LF | 10CA | 000LF | 2.8 | BLACK | |
| 320CALF | 2 | 10CA | 045LF | 12CA | 040LF | 2.5 | BLACK | |
| 500CA | 0 | 00CA | 505 | 10CA | 500 | 2.8 | NATURAL | |
| 520CA | 2 | 00CA | 545 | 12CA | 540 | 2.5 | NATURAL | |
| 500CALF | 0 | 00CA | 505LF | 10CA | 500LF | 2.8 | NATURAL | |
| 520CALF | 2 | 00CA | 545LF | 12CA | 540LF | 2.5 | NATURAL | |
| 600CA | 0 | 10CA | 505 | 00CA | 500 | 2.8 | NATURAL | |
| 620CA | 2 | 10CA | 545 | 02CA | 540 | 2.5 | NATURAL | |
| 600CALF | 0 | 10CA | 505LF | 00CA | 500LF | 2.8 | NATURAL | |
| 620CALF | 2 | 10CA | 545LF | 02CA | 540LF | 2.5 | NATURAL | |
| 700CA | 0 | 10CA | 505 | 10CA | 500 | 2.8 | NATURAL | |
| 720CA | 2 | 10CA | 545 | 12CA | 540 | 2.5 | NATURAL | |
| 700CALF | 0 | 10CA | 505LF | 10CA | 500LF | 2.8 | NATURAL | |
| 720CALF | 2 | 10CA | 545LF | 12CA | 540LF | 2.5 | NATURAL | |
| 800CA | 0 | 00CA | 505 | 00CA | 500 | 2.8 | NATURAL | |
| 820CA | 2 | 00CA | 545 | 02CA | 540 | 2.5 | NATURAL | |
| 800CALF | 0 | 00CA | 505LF | 00CA | 500LF | 2.8 | NATURAL | |
| 820CALF | 2 | 00CA | 545LF | 02CA | 540LF | 2.5 | NATURAL | |

NOTES:

- REFER TO HEADER DRAWING 92140 AND EJECT MECHANISM 95079 FOR ADDITIONAL DIMENSIONS, MATERIAL, AND PLATING INFORMATION.
- RECOMMENDED SCREW TORQUE: 1.0 TO 1.5 MAX in.-lbs. (1.2-1.7 cm.-kgs). RECOMMENDED HOLD-DOWN: 2mm SCREWS AND NUTS. SEE DRAWINGS 95121 AND 92869.
- FOR SINGLE-DECK APPLICATIONS, SEE DRAWING 95620.
- ADD "H" TO END OF PRODUCT NO. FOR OPTIONAL SOLDERABLE HOLD DOWN.

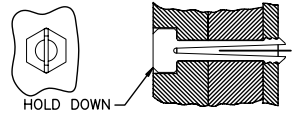

| PRODUCT NO. | STAND-OFF | HOLD-DOWN P/N(4) |
|-----------------------|-----------|------------------|
| 94050-X00CAH/X00CAHLF | 0mm | 93925-005 |
| 94050-X20CAH/X20CAHLF | 2mm | 93925-006 |

CONFIDENTIAL

| | | | | | | | |
|-------------|----------------|---------------------------------------|------|---------------|-----------|------------------------|----------------------|
| mat'l. code | | tolerances unless otherwise specified | | CUSTOMER COPY | | www.fciconnect.com | |
| ltr | ecr no | dr | date | linear | .X±.3 | projection | title |
| G | | | | angles | .XX±.13 | MM | DOUBLE DECK |
| | | | | dr | .XXX±.051 | | 5V EJECT HEADER ASSY |
| | | | | engr | 0' ±2" | product family | MCS |
| | | | | chr | | size | dwg no |
| | | | | appd | | scale | 94050 |
| | | | | | | 1/1 | sheet |
| sheet index | revision sheet | | | | | | 2 of 3 |

1 | 2

3

4

ACAD

PDM: Rev.G

STATUS: Released

Printed: Oct 12, 2010

Tous droits strictement réservés. Reproduction ou communication à des tiers
interdite sous quelque forme que ce soit sans autorisation écrite du propriétaire.
Property of FCI. Copyright FCI. Prohibits reproduction FCI.

All rights strictly reserved. Reproduction or issue to third parties in any
form whatever is not permitted without written authority from the proprietor.
Property of FCI. Copyright FCI.

PRODUCT NUMBER

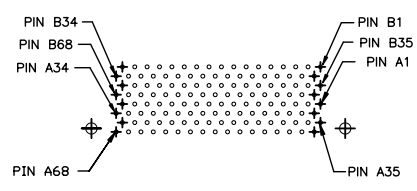
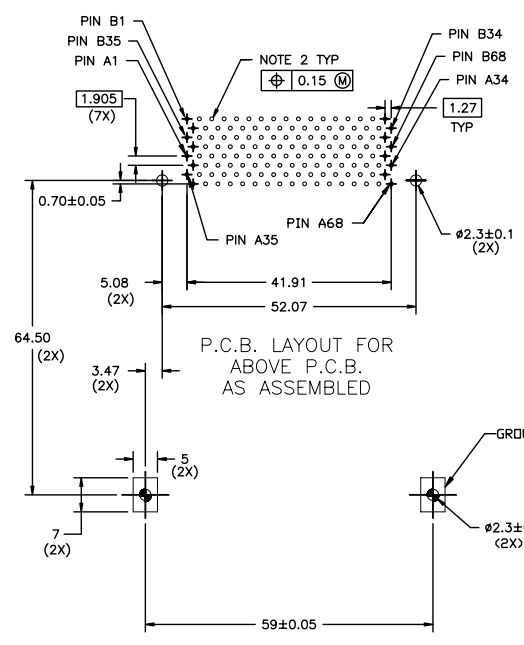

CONFIDENTIAL

NOTES:

1. ALL TOLERANCES ±0.15 UNLESS NOTED.
2. RECOMMENDED DIAMETER IS #1.0 FOR PROCESSES USING PASTE REFLOW, HOLE MAY BE AS SMALL AS #0.79
3. GS-14-920 SPEC. SHOULD BE APPLIED LEAD FREE P/N.
4. IF LEAD FREE P/N.THE HOUSING WILL WITHSTAND EXPOSURE TO 260°C PEAK TEMPERATURE FOR 10 SECONDS IN A WAVE SOLDER APPLICATION WITH A 1.00MM MINIMUM THICK CIRCUIT BOARD.

| | | | | | | |
|-------------|----------------|---------------------------------------|------|---------------|----------------------------------|--------------|
| mat'l. code | | tolerances unless otherwise specified | | CUSTOMER COPY | A FCI www.fciconnect.com | |
| ltr | ecr no | dr | date | projection | title | |
| G | | | | | DOUBLE DECK 5V EJECT HEADER ASSY | |
| | | | | MM | product family | code |
| | | | | | MCS | - |
| | | | | scale | size | dwg no |
| | | | | | 2:1 | A4 |
| sheet index | revision sheet | | | | cage code | sheet 3 of 3 |