

Tous droits strictement réservés. Reproduction ou communication à des tiers sans autorisation écrite du propriétaire.
 Copyright BERG ELECTRONICS S.r.l.
 Droits de reproduction BERG ELECTRONICS S.r.l.

All rights strictly reserved. Reproduction or issue to third parties in any form or by any means without written authority from the proprietor.
 Copyright BERG ELECTRONICS S.r.l.

| PRODUCT NO. | DIM.L |
|------------------|-------|
| 10001489-050HA | 5.0 |
| 10001489-056HA | 5.6 |
| 10001489-050HALF | 5.0 |
| 10001489-056HALF | 5.6 |

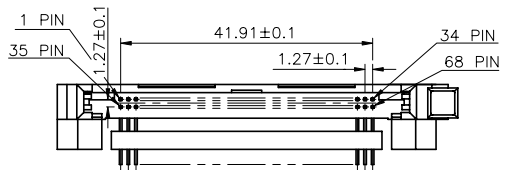
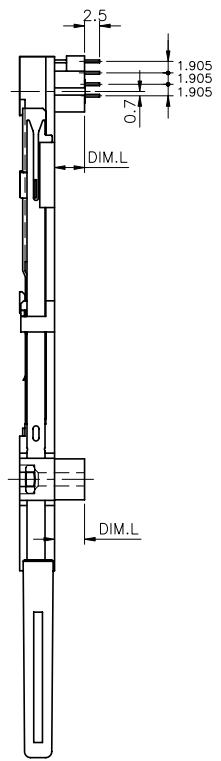
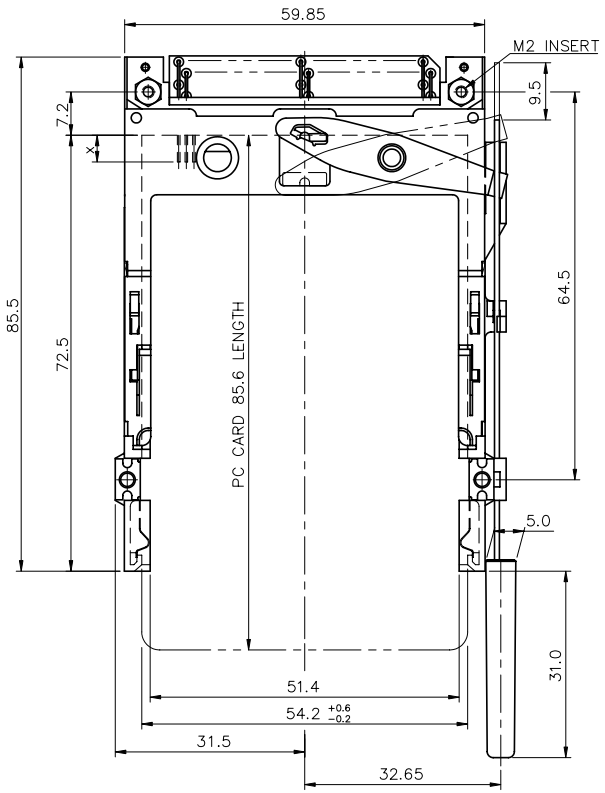

| mat'l code | | tolerance unless otherwise specified | | CUSTOMER COPY | | FCI www.fciconnect.com | |
|------------|----------|--------------------------------------|----------|---------------|--------------|------------------------|----------------------------|
| rev. | ecn no. | dr | date | linear | ±0.30 | projection | title |
| A | T20084 | WL | 03/18/02 | angles | ± 2° | ↑ | SINGLE DECK EJECTOR HEADER |
| B | T03-0017 | WL | 01/16/03 | | | | 5.0V R/A TYPE 1/2/3 |
| C | T03-0079 | WL | 03/08/03 | | | | product family |
| D | N04-0094 | WB | 12/01/04 | dr | WENDY CHEN | 02/22/02 | size |
| | | | | engr | MINERVA WANG | 02/22/02 | dwg no. |
| | | | | chr | MINERVA WANG | 02/22/02 | 10001489 |
| | | | | appd | JENN TSAO | 02/22/02 | code |
| sheet | revision | D | D | | | | 1 OF 2 |
| index | sheet | 1 | 2 | | | | |

PDM: Rev:D STATUS: Released Printed: Oct 12, 2010

