

ADSL LINE TRANSFORMER

For Globespan CO Chipsets



- Matched to Globespan G24 ADSL+ Chipset with Elantec Line Drivers
- Designed to comply with EN60950 basic insulation requirements for working voltages up to 250 Vrms
- Compact SMD footprint

Electrical Specifications @ 25°C — Operating Temperature -40°C to 85°C

Part Number	Turns Ratio Ratio (Line:Chip)	OCL Primary ($\mu\text{H} \pm 7\%$)	Leakage Inductance ($\mu\text{H} \text{ MAX}$)	Interwinding Capacitance (pF MAX)	Isolation Voltage (Vrms)	THD @ 25kHz, 5Vrms (dB MIN)
B2517JB	0.95 : 1	760	7.5 - 10.5	25	1500	-75
BX2485L	0.90 : 1	1000	7.0 - 10.5	15	1500	-78

NOTE: Transformers are shipped in trays unless Tape & Reel packaging is specified by adding the suffix "T" to the part number (i.e. B2517JBT).

Mechanical

Schematic

B2517JB/BX2485L

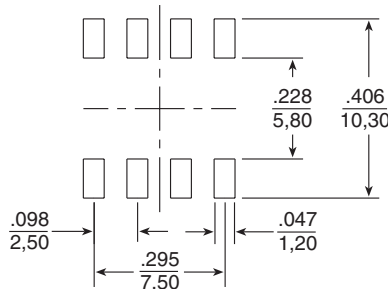
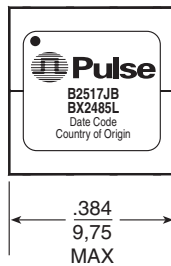

SUGGESTED PAD LAYOUT

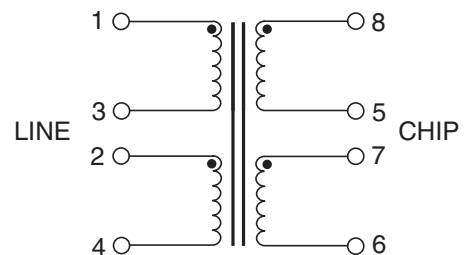
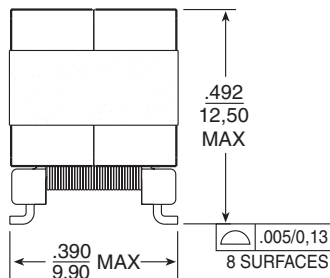
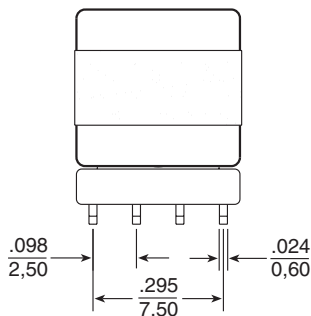

Weight 3.2 grams
 Tape & Reel 175/reel
 Tray90/tray

Dimensions: $\frac{\text{Inches}}{\text{mm}}$

Unless otherwise specified, all tolerances are $\pm \frac{.010}{0.25}$

For More Information :

UNITED STATES (Worldwide)	UNITED KINGDOM (Northern Europe)	FRANCE (Southern Europe)	SINGAPORE (Southern Asia)	TAIWAN, R.O.C. (Northern Asia)	HONG KONG (China/Hong Kong)	DISTRIBUTOR
12220 World Trade Drive San Diego, CA 92128 U.S.A. http://www.pulseeng.com TEL: 858 674 8100 FAX: 858 674 8262	3 Huxley Road Surrey Research Park Guildford, Surrey GU2 5RE United Kingdom TEL: 44 1483 401700 FAX: 44 1483 401701	Zone Industrielle F-39270 Orgelet France TEL: 33 3 84 35 04 04 FAX: 33 3 84 25 46 41	150 Kampong Ampat #07-01/02 KA Centre Singapore 368324 TEL: 65 6287 8998 FAX: 65 6280 0080	3F-4, No. 81, Sec. 1 HsinTai Wu Road Hsi-Chih, Taipei Hsien Taiwan, R.O.C. Tel: 886 2 2698 0228 FAX: 886 2 2698 0948	Unit 11, 11/F Wah Lai Industrial Centre 10-14 Kwei Tei Street, Fotan, Shatin, Hong Kong TEL: 852 2788 6588 FAX: 852 2776 1055	

Performance warranty of products offered on this data sheet is limited to the parameters specified. Data is subject to change without notice. Other brand and product names mentioned herein may be trademarks or registered trademarks of their respective owners.

©2005, Pulse Engineering, Inc. All Rights Reserved.

B836.B (6/05)