

Tous droits strictement réservés. Reproduction ou communication à des tiers sans autorisation écrite du propriétaire. FCI ELECTRONICS INC. Droits de reproduction BERG ELECTRONICS bv

All rights strictly reserved. Reproduction or issue to third parties in any form without written authority from the proprietor. FCI ELECTRONICS INC. Copyright BERG ELECTRONICS bv

PRODUCT NO.	DIM.M
61125-005CA/005CALF	10.0
61125-025CA/025CALF	6.55
61125-045CA/045CALF	6.55
61125-055CA/055CALF	6.55
61125-025CAC/025CACLF	6.55
61125-045CAC/045CACLF	6.55
61125-055CAC/055CACLF	6.55

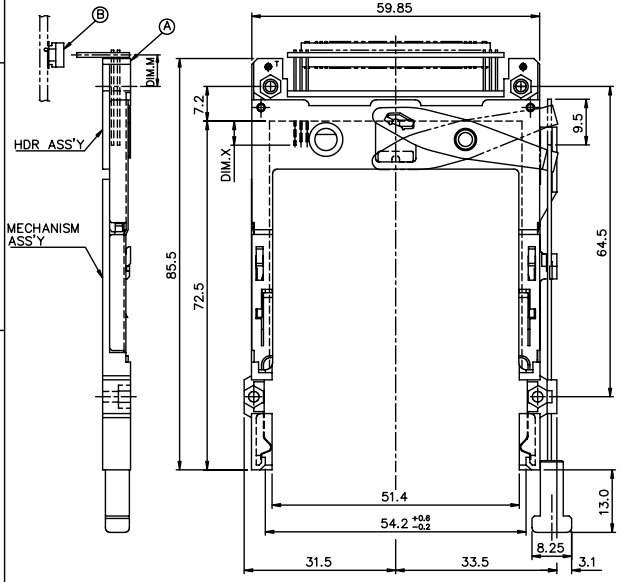

PRODUCT NO.	DIM.M
61125-020CA/020CALF	-0.3
61125-220CA/220CALF	2.15
61125-040CA/040CALF	-0.3
61125-050CA/050CALF	-0.3
61125-050CAN/050CANLF	-0.3
61125-020CAC/020CACLF	-0.3
61125-040CAC/040CACLF	-0.3
61125-050CAC/050CACLF	-0.3

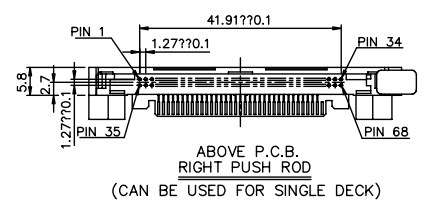
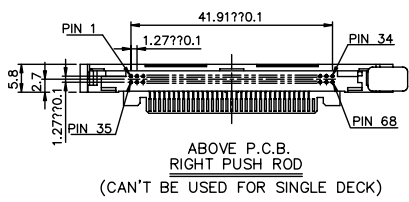
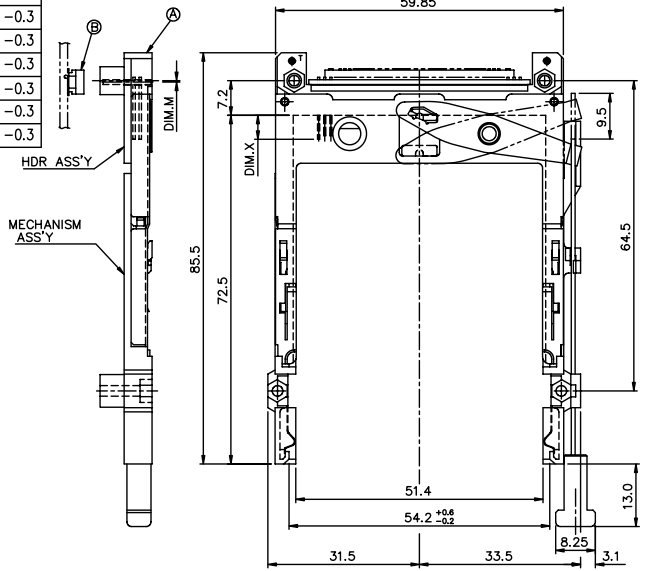

mat'l code		tolerance unless otherwise specified		CUSTOMER COPY		FCI		www.fciconnect.com	
rev.	ecn no.	dr	date	linear	±0.30	projection	title	EJECTOR HEADER ASS'Y	
J	N05-0063	w	03/04/05				3.3V, SMT TYPE 1/2/3		
K	N05-0140	w	05/31/05						
D	T10132	w	05/11/01	angles	± 2°				
E	T10162	w	06/14/01	dr	WENDY CHEN 07/11/95	unit	product family	PCMCIA	
F	T20036	w	01/30/02	engr	JOSEPH HSIA 07/11/95	mm/inch	size	dwg no.	
G	T20234	w	07/25/02	chr	JOSEPH HSIA 07/11/95	scale	A3	61125	
H	T03-0216	w	06/09/03	appd	JENN TSAO 07/11/95	1:2:1		sheet 1 of 6	
sheet	revision	K	J	J	J	K	J		
index	sheet	1	2	3	4	5	6		

Tous droits strictement réservés. Reproduction ou communication à des tiers sans autorisation écrite du propriétaire.
 All rights strictly reserved. Reproduction or issue to third parties in any form without written authority from the proprietor.
 Copyright BERG ELECTRONICS S.A.
 Droits de reproduction BERG ELECTRONICS S.A.

All rights strictly reserved. Reproduction or issue to third parties in any form without written authority from the proprietor.
 Copyright BERG ELECTRONICS S.A.

PRODUCT NO.	DIM.M
61125-105CA/105CALF	10.0
61125-125CA/125CALF	6.55
61125-145CA/145CALF	6.55
61125-155CA/155CALF	6.55

PRODUCT NO.	DIM.M
61125-120CA/120CALF	-0.3
61125-140CA/140CALF	-0.3
61125-150CA/150CALF	-0.3

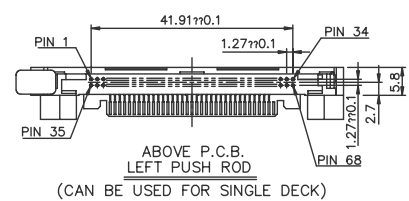
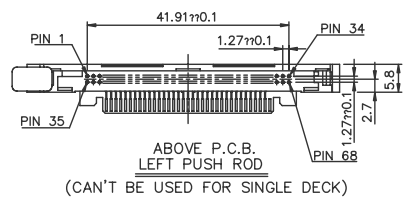
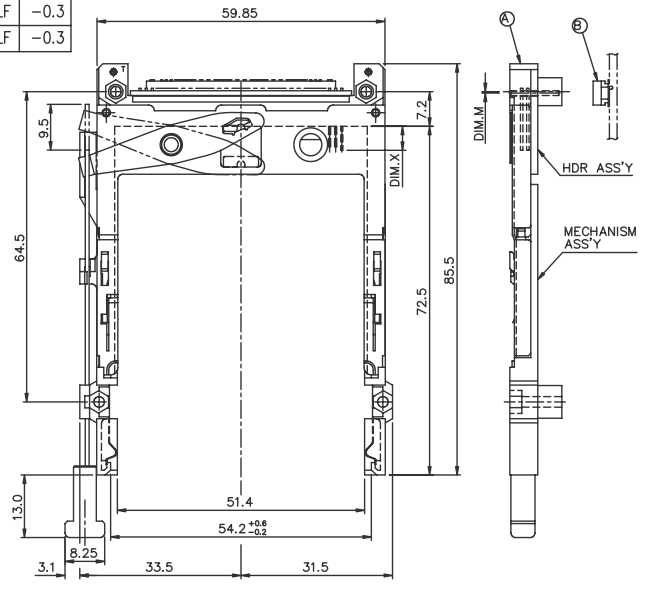
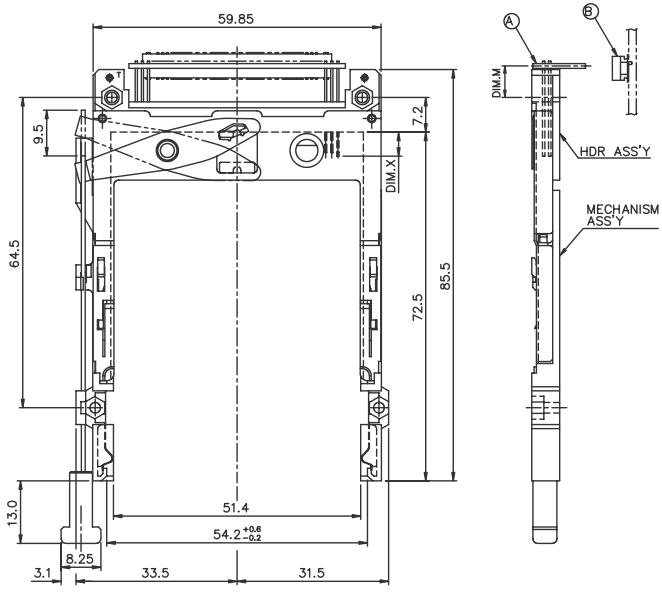

mat'l code	tolerance unless otherwise specified	CUSTOMER COPY	 www.fciconnect.com
rev. J	linear ±0.30	projection	
ecn no.	angles ± 2°	title	EJECTOR HEADER ASS'Y
dr	dr WENDY CHEN 07/11/95	product family	3.3V, SMT TYPE 1/2/3
enr	enr JOSEPH HSIA 07/11/95	unit	mm/inch
chr	chr JOSEPH HSIA 07/11/95	size	A3
app	app JENN TSAO 07/11/95	scale	1.2:1
sheet index	revision sheet	product family	61125
		dwg no.	code
			sheet 2 of

Tous droits strictement réservés. Reproduction ou communication à des tiers sans autorisation écrite du propriétaire. FCI ELECTRONICS. Droits de reproduction BERG ELECTRONICS bv

All rights strictly reserved. Reproduction or issue to third parties in any form without written authority from the proprietor. FCI ELECTRONICS. Copyright BERG ELECTRONICS bv

PRODUCT NO.	DIM.M
61125-605CA/650CALF	10.0
61125-625CA/625CALF	6.55
61125-645CA/645CALF	6.55
61125-655CA/655CALF	6.55

PRODUCT NO.	DIM.M
61125-620CA/620CALF	-0.3
61125-640CA/640CALF	-0.3
61125-650CA/650CALF	-0.3

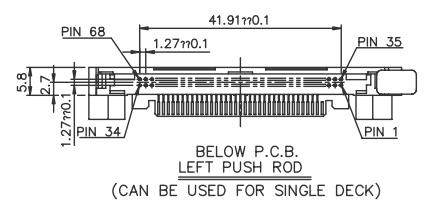
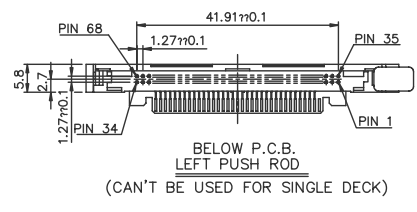
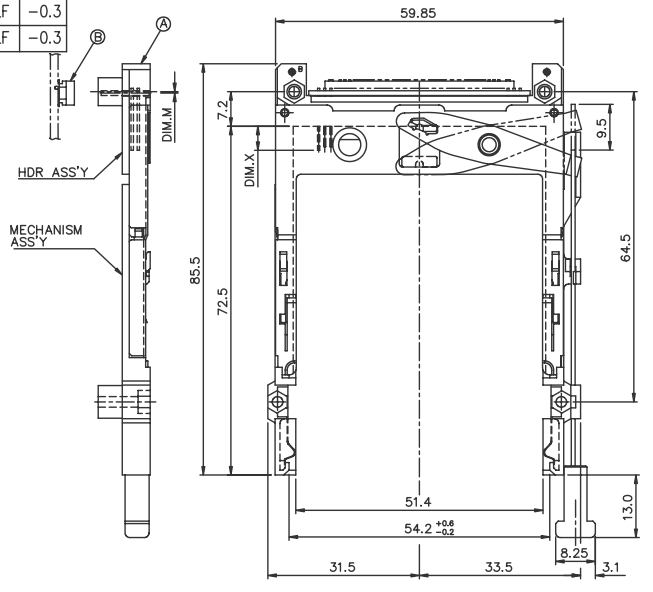
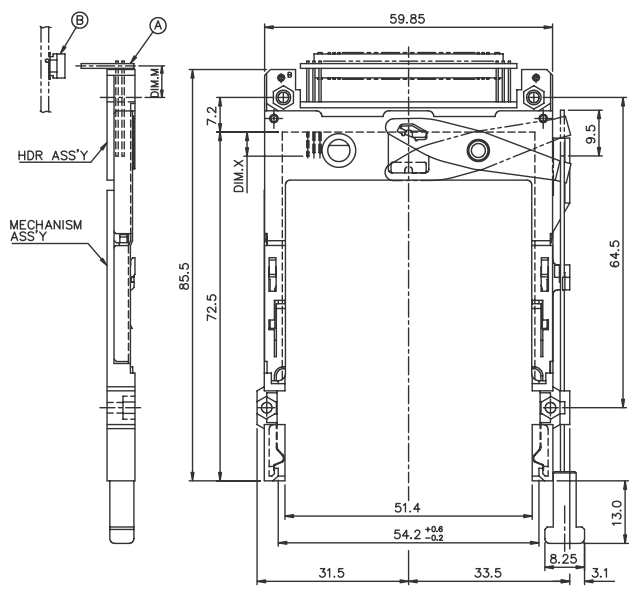

BELOW P.C.B. LEFT PUSH ROD
(CAN BE USED FOR SINGLE DECK)

mat'l code	tolerance unless otherwise specified	CUSTOMER COPY	 www.fciconnect.com
rev. J	linear ±0.30	projection	
ecn	angles ± 2°	unit	title
no.	dr WENDY CHEN 07/11/95	mm/inch	EJECTOR HEADER ASS'Y
date	enrg JOSEPH HSIA 07/11/95	size	3.3V, SMT TYPE 1/2/3
	chr JOSEPH HSIA 07/11/95	scale	product family
	appd JENN TSAO 07/11/95	1.2:1	61125
			code
sheet	revision		3 of
index	sheet		

Tous droits strictement réservés. Reproduction ou communication à des tiers int.
 without written authority from the proprietor.
 FCI ELECTRONICS
 Droits de reproduction BERG ELECTRONICS by

All rights strictly reserved. Reproduction or issue to third parties in any form
 without written authority from the proprietor.
 FCI ELECTRONICS
 Copyright BERG ELECTRONICS by

PRODUCT NO.	DIM.M
61125-505CA/505CALF	10.0
61125-525CA/525CALF	6.55
61125-545CA/545CALF	6.55
61125-555CA/555CALF	6.55

PRODUCT NO.	DIM.M	DIM.S
61125-520CA/520CALF	-0.3	
61125-540CA/540CALF	-0.3	13.0
61125-550CA/550CALF	-0.3	
61125-520DA/520DALF	-0.3	15.6
61125-520FA/520FALF	-0.3	21.0

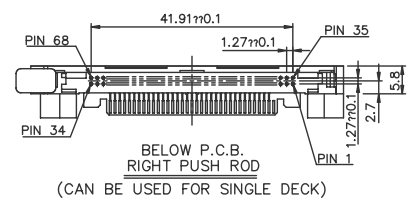
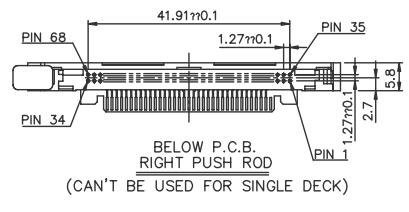
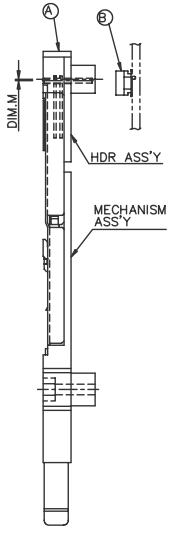
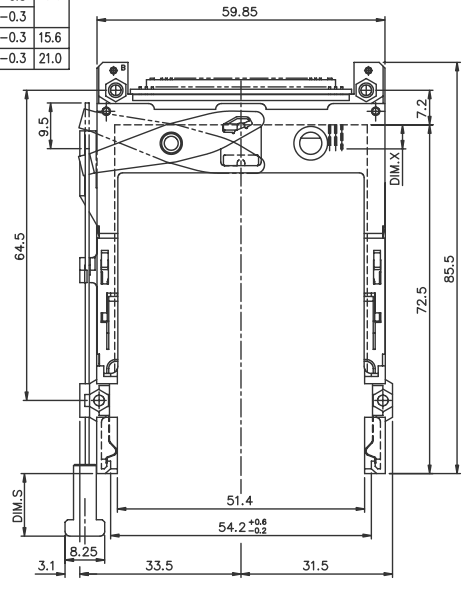
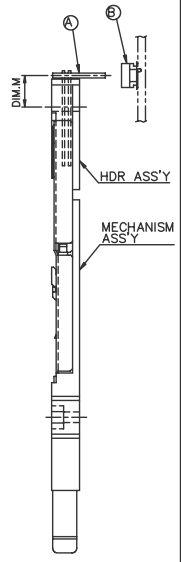
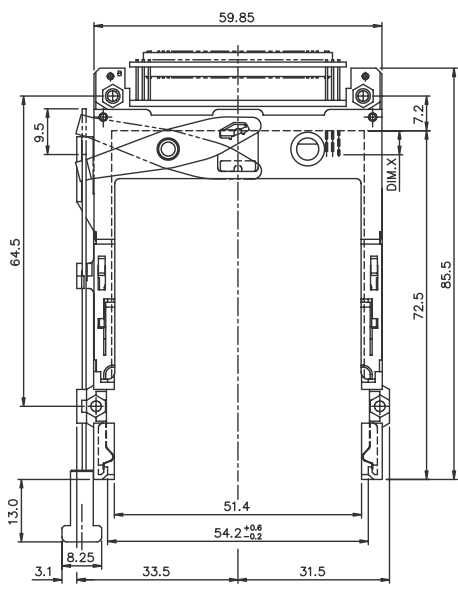

mat'l code	tolerance unless otherwise specified	CUSTOMER COPY	 www.fciconnect.com
rev. J	linear ±0.30	projection	
ecn	angles ± 2°	title	EJECTOR HEADER ASS'Y
no.	dr WENDY CHEN 07/11/95	unit	3.3V, SMT TYPE 1/2/3
dr	enr JOSEPH HSIA 07/11/95	product family	PCMCA
enr	chr JOSEPH HSIA 07/11/95	size	dwg no. 61125
chr	appd JENN TSAO 07/11/95	scale	A3
appd		sheet	4 OF
sheet index	revision sheet		

PDM: Rev:K STATUS Released Printed: Oct 12, 2010

Tous droits strictement réservés. Reproduction ou communication a des tiers int. sans autorisation écrite du propriétaire. FCI ELECTRONICS. Droits de reproduction BERG ELECTRONICS by

All rights strictly reserved. Reproduction or issue to third parties in any form without the prior written authority from the proprietor. FCI ELECTRONICS. Copyright BERG ELECTRONICS by

DESCRIPTION : ABOVE PCB, DECK AND PUSH ROD LOCATION ARE AS VIEW BY USER.





- NOTES:
1. 8mm MIN. CARD EJECT.
 2. EJECT TRAVEL: 9.5mm
 3. PUSH ROD LOCATION AND P.C.B. SIDE ARE AS APPEARS INSTALLED.
 4. MATERIAL
 - 4.1 HEADER ASS'Y:
PLASTIC : HOUSING ...LCP UL94V-0 BLACK
PIN : PHOSPHOR BRONZE
PCB : FR4
 - 4.2 EJECT MECHANISM ASS'Y:
PLASTIC : GUIDE: POLYPHTHARAMID UL94V-0 BLACK
: BUTTON: POLYPHTHARAMID UL94V-0 BLACK
PLATE AND PUSH ROD : STAINLESS
EMI CONTACT: PHOSPHOR BRONZE
 5. FINISH (PIN)
UNDER PLATING : 0.5µm MIN. Ni
CONTACT AREA : 0.1µm MIN. GOLD OVER
0.5µm MIN. Pd-Ni
SOLDER TAIL (FOR TIN LEAD OPTION) : 2.5µm MIN. Sn-Pb
SOLDER TAIL (FOR LEAD FREE OPTION) : 2.5µm MIN. PURE TIN
 6. DIM "X"

4.25±0.1	3.5±0.1	5.0±0.1
OTHERS	36,67	1,17,34,35,51,68

7. FOR P/N: 61125-050CAN AND 61125-050CANLF:
 - a. TIGHTENING TORQUE OF SCREW: 1.5 ~ 2.0 Kgf-cm
 - b. LUBRICANT SHOULD BE SPREAD TO MATING AREA OF PINS.
8. IF LEAD FREE P.N. THE HOUSING WILL WITHSTAND EXPOSURE TO 260°C PEAK TEMPERATURE FOR 10 SECONDS IN A WAVE SOLDER APPLICATION WITH A 1.00MM MINIMUM THICK CIRCUIT BOARD.
9. IF LEAD FREE P.N. THE PRODUCT MEETS EUROPEAN UNION DIRECTIVES AND OTHER COUNTRY REGULATIONS AS DISCRIBED IN GS-22-008
10. LEAD FREE P/N PACKAGING MEETS GS-14-920 SPECIFICATION
11. PART NUMBER 61125-****CAC, -****CACLF IS FOR CISCO

ORDERING INFORMATION			
NAME	PART NO.	PART NO.	Q'TY
Ⓐ EJECT HEADER ASS'Y	61125-****	61125-****LF	1
Ⓑ MATING RECEPTACLE	91931-31169	91931-31169LF	1

LOWER DECK					
Ⓐ PRODUCT NO.	STAND-OFF HIGH DIM. L	PUSH ROD LOCATION ④	P.C.B. SIDE ⑤	P.C.B LAYOUT RECOMMENDED	Ⓒ MATING RECEPTACLE
61125-020CA/020CALF	2.2	RIGHT	ABOVE	P/N: TA-1056	RECEPTACLE PART NUMBER: 91931-31169 91931-31169LF
61125-220CA/220CALF	2.2	RIGHT	ABOVE	SEE PAGE 6	
61125-040CA/040CALF	4.3	RIGHT	ABOVE	SEE DRAWING P/N: TA-1056	
61125-050CA/050CALF	5.0				
61125-050CAN/050CANLF	5.0				
61125-020CAC/020CACLF	2.2				
61125-040CAC/040CACLF	4.3	LEFT	ABOVE	SEE DRAWING P/N: TA-1056	
61125-050CAC/050CACLF	5.0				
61125-120CA/120CALF	2.2				
61125-140CA/140CALF	4.3				
61125-150CA/150CALF	5.0	RIGHT	BELOW	SEE DRAWING P/N: TA-1056	
61125-520CA/520CALF	2.2				
61125-520FA/520FALF	2.2				
61125-520DA/520DALF	2.2				
61125-540CA/540CALF	4.3	LEFT	BELOW	SEE DRAWING P/N: TA-1056	
61125-550CA/550CALF	5.0				
61125-620CA/620CALF	2.2				
61125-640CA/640CALF	4.3				
61125-650CA/650CALF	5.0				

UPPER DECK						
Ⓐ PRODUCT NO.	JOINT WITH LOWER DECK STAND-OFF HIGH(DIM. L)	PUSH ROD LOCATION ④	P.C.B. SIDE ⑤	Ⓒ MATING RECEPTACLE	MOUNT STYLE TO PCB AND PUSH ROD SIDE	
61125-005CA/005CALF	0.0	RIGHT	ABOVE	RECEPTACLE PART NUMBER: 91931-31169 91931-31169LF		
61125-025CA/025CALF	2.2					
61125-045CA/045CALF	4.3					
61125-055CA/055CALF	5.0					
61125-025CAC/025CACLF	2.2	LEFT	ABOVE			
61125-045CAC/045CACLF	4.3					
61125-055CAC/055CACLF	5.0					
61125-105CA/105CALF	0.0					
61125-125CA/125CALF	2.2	RIGHT	BELOW			
61125-145CA/145CALF	4.3					
61125-155CA/155CALF	5.0					
61125-505CA/505CALF	0.0					
61125-525CA/525CALF	2.2	LEFT	BELOW			
61125-545CA/545CALF	4.3					
61125-555CA/555CALF	5.0					
61125-605CA/605CALF	0.0					
61125-625CA/625CALF	2.2					

- NOTES:
1. IT CAN'T BE USED FOR SINGLE DECK.
 2. IT MUST BE ASSEMBLED BY USER FOR DOUBLE DECK APPLICATION.(PLEASE REFER TO P/N 61124)

mat'l code	tolerance unless otherwise specified	CUSTOMER COPY	 www.fciconnect.com
rev. K	linear	projection	
ecn no.	angles	unit	product family PCMCIA
dr	dr WENDY CHEN 07/11/95	mm/inch	code
engr	engr JOSEPH HSIA 07/11/95	scale	size 61125
chr	chr JOSEPH HSIA 07/11/95	1:2:1	sheet 5 of
appd	appd JENN TSAO 07/11/95		
sheet index	revision sheet		

Tous droits strictement réservés. Reproduction ou communication à des tiers sans autorisation écrite du propriétaire. FCI ELECTRONICS. Droits de reproduction BERG ELECTRONICS by

All rights strictly reserved. Reproduction or issue to third parties in any form without the prior written authority from the proprietor. Copyright BERG ELECTRONICS by

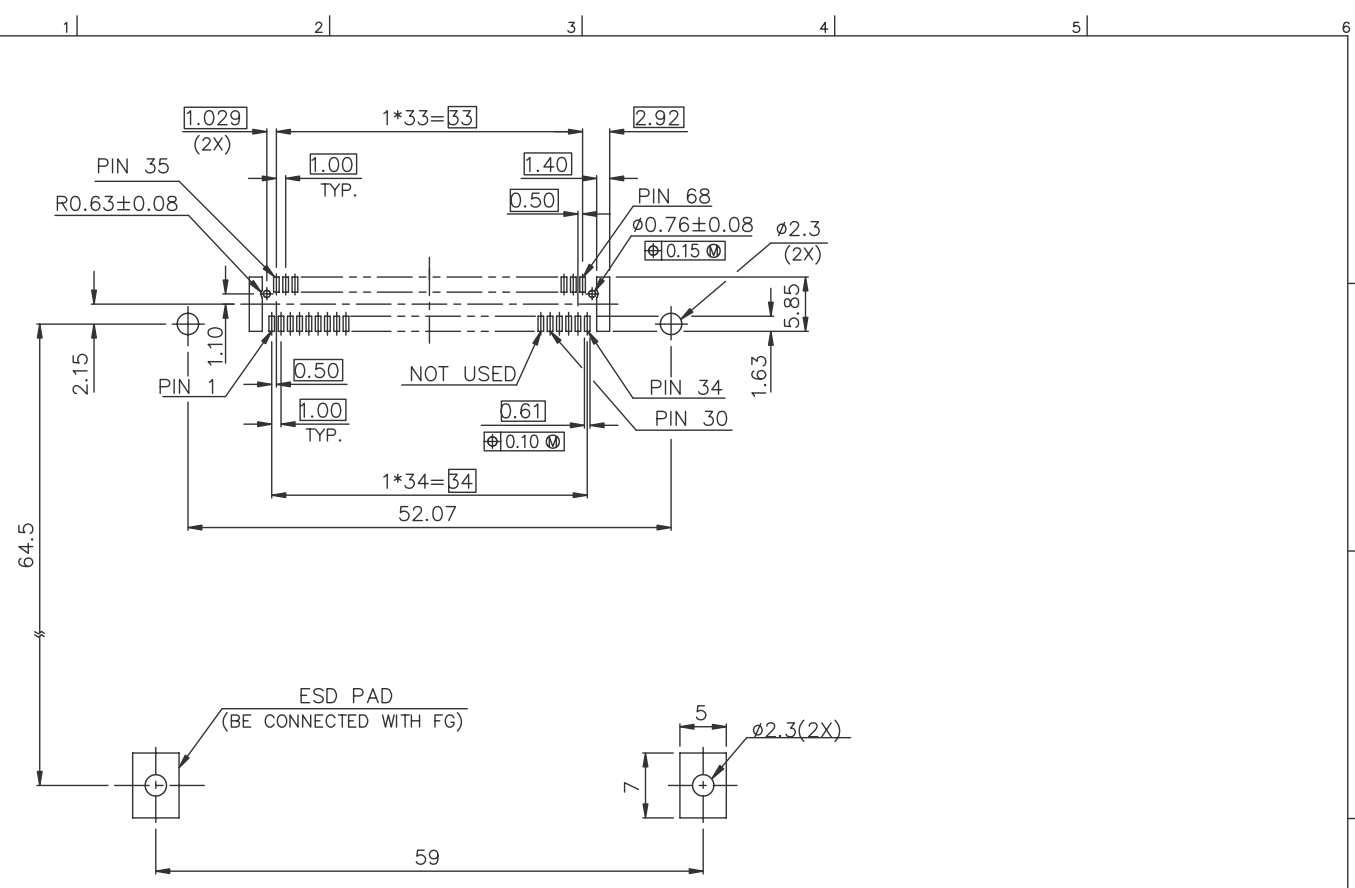

BOARD VIEW FROM CONNECTOR MOUNTED SIDE
TOP OF BOARD IN APPLICATION
FOR 61125-220CA/220CALF ONLY

mat'l code		tolerance unless otherwise specified		CUSTOMER COPY		FCI www.fciconnect.com	
rev. J	ecn no.	dr	date	linear	±0.1	projection	title P.C.B LAYOUT
				angles			
				dr	WENDY CHEN 01/30/02	unit	product family PCMG
				engr	MINERVA WANG 01/30/02	mm/inch	code
				chr	MINERVA WANG 01/30/02	scale	size A3
				appd	JENN TSAO 01/30/02	1.2:1	dwg no. 61125
sheet index	revision sheet						sheet 6 OF

PDM: Rev:K STATUS Released Printed: Oct 12, 2010