

SMD Inductors(Coils) For Power Line(Multilayer, Magnetic Shielded)

Conformity to RoHS Directive

MLZ Series MLZ2012

The MLZ Series is a new line of laminated choke coils for decoupling with the industry's best DC superimposition characteristics and lowest DC resistance*. TDK has developed this coil using its proprietary ferrite material technique and dense electrodes.

The MLZ Series exerts an excellent effect mainly on the decoupling of power circuits. It also exerts an effect on audio lines because of its low DC resistance.

The DC superimposition characteristics of the MLZ2012-W Series (IDC UP type) have been improved by up to 250% in comparison with those of other existing products. New addition of 22 and 47 μ H products has satisfied more needs: low through to high frequency ranges are supported.

* The MLZ Series was regarded as having the industry's best DC superimposition characteristics and lowest DC resistance according to research conducted in September 2009.

FEATURES

- The IDC UP type is a line of products with the industry's best DC superimposition characteristics.
- High-inductance(22 and 47 μ H products have been introduced).
- Thanks to a broad inductance range (0.1 to 47 μ H), wide-ranging needs (from low through to high frequency ranges) can be satisfied.

APPLICATIONS

Modules such as digital cellular phone and camera module, Netbooks, note PCs, DSCs, DVCs, video games, portable memory audio devices, navigation systems, PNDs, TVs, W-LANs, solid state drives

SPECIFICATIONS

Operating temperature range	-55 to +125°C
Storage temperature range	-55 to +125°C

RECOMMENDED SOLDERING CONDITION REFLOW SOLDERING

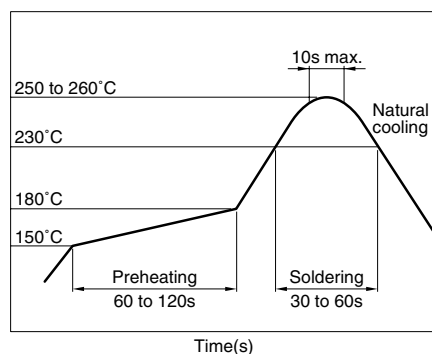

- Conformity to RoHS Directive: This means that, in conformity with EU Directive 2002/95/EC, lead, cadmium, mercury, hexavalent chromium, and specific bromine-based flame retardants, PBB and PBDE, have not been used, except for exempted applications.
- Please contact our Sales office when your application are considered the following:
The device's failure or malfunction may directly endanger human life (e.g. application for automobile/aircraft/medical/nuclear power devices, etc.)

• All specifications are subject to change without notice.

PRODUCT IDENTIFICATION

MLZ	2012	A	1R0	M	T
(1)	(2)	(3)	(4)	(5)	(6)

(1) Series name

(2) Dimensions L×W

2012	2.0×1.25mm
------	------------

(3) Material code

(4) Inductance value

R10	0.1 μ H
1R0	1.0 μ H
100	10.0 μ H

(5) Management symbol

M	STD
W	IDC-UP

(6) Packaging style

T	Taping [reel]
---	---------------

PACKAGING STYLE AND QUANTITIES

Packaging style	Thickness T(mm)	Quantity
Taping	0.85	4000 pieces/reel
	1.25	2000 pieces/reel

HANDLING AND PRECAUTIONS

- Before soldering, be sure to preheat components.
The preheating temperature should be set so that the temperature difference between the solder temperature and product temperature does not exceed 150°C.
- After mounting components onto the printed circuit board, do not apply stress through board bending or mishandling.
- The inductance value may change due to magnetic saturation if the current exceeds the rated maximum.
- Do not expose the inductors to stray magnetic fields.
- Avoid static electricity discharge during handling.
- When hand soldering, apply the soldering iron to the printed circuit board only. Temperature of the iron tip should not exceed 350°C. Soldering time should not exceed 3 seconds.

SHAPES AND DIMENSIONS/RECOMMENDED PC BOARD PATTERN

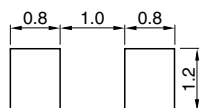
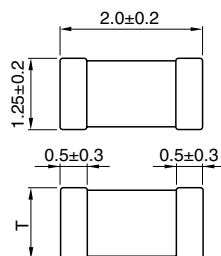

Dimensions in mm

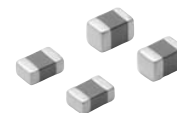

T(Thickness)	Weight(mg)
0.85±0.2	10
1.25±0.2	14

ELECTRICAL CHARACTERISTICS

Classification	Part No.	Inductance (μH)	Inductance tolerance	Thickness (mm)	Test frequency L (MHz)	Test current L (mA)	Self-resonant frequency (MHz)typ.	DC resistance (Ω)±30%	Rated current (mA)
High frequency supported	MLZ2012DR10MT	0.10	±20%	0.85	25	1.0	500	0.07	1000
	MLZ2012DR22MT	0.22	±20%	0.85	25	1.0	330	0.13	800
	MLZ2012DR47MT	0.47	±20%	1.25	25	1.0	230	0.18	550
STD	MLZ2012A1R0MT	1.0	±20%	0.85	10	1.0	160	0.12	220
	MLZ2012A2R2MT	2.2	±20%	0.85	10	1.0	120	0.20	160
	MLZ2012E4R7MT	4.7	±20%	0.85	2	0.1	70	0.30	80
	MLZ2012E100MT	10.0	±20%	1.25	2	0.1	50	0.40	60
IDC-UP	MLZ2012A1R0WT	1.0	±20%	0.85	10	1.0	160	0.10	280
	MLZ2012A2R2WT	2.2	±20%	0.85	10	1.0	120	0.15	210
	MLZ2012M4R7WT	4.7	±20%	0.85	2	0.1	70	0.30	180
	MLZ2012M100WT	10.0	±20%	1.25	2	0.1	50	0.47	150
	MLZ2012M220WT	22	±20%	1.25	2	0.1	35	2.2	60
	MLZ2012M470WT	47	±20%	1.25	2	0.1	20	4.3	50

- Test equipment
Inductance: Ag4294A-16034G

TYPICAL ELECTRICAL CHARACTERISTICS

INDUCTANCE vs. FREQUENCY CHARACTERISTICS

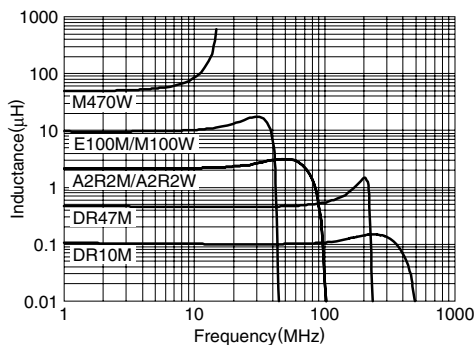

IMPEDANCE vs. FREQUENCY CHARACTERISTICS

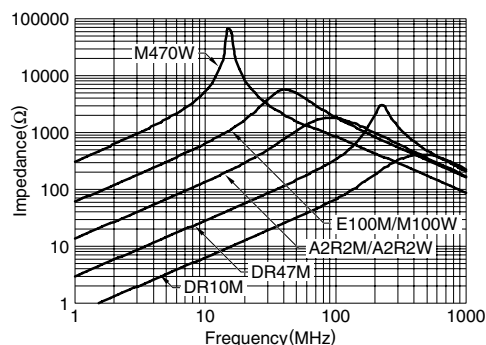

INDUCTANCE CHANGE vs. DC SUPERPOSITION CHARACTERISTICS

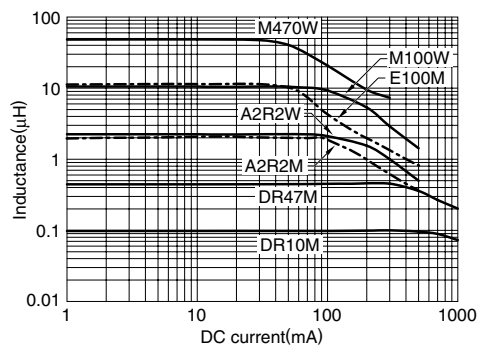

TEMPERATURE CHARACTERISTICS

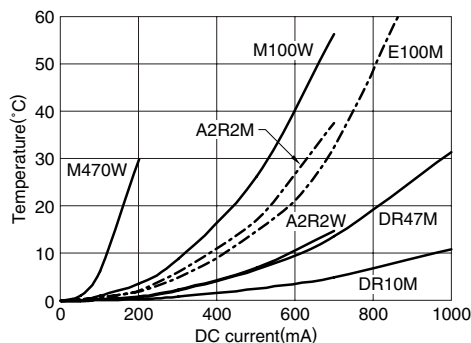

• All specifications are subject to change without notice.

PACKAGING STYLES

REEL DIMENSIONS

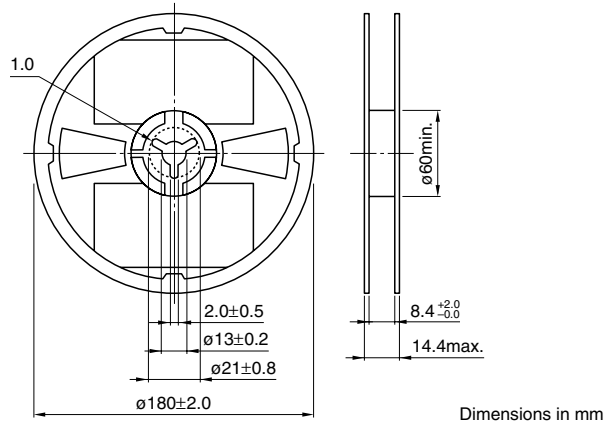

TAPE DIMENSIONS

t=0.85mm

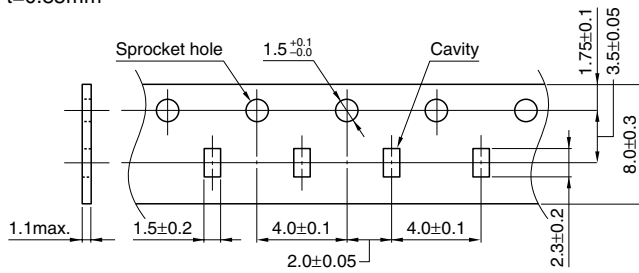

t=1.25mm

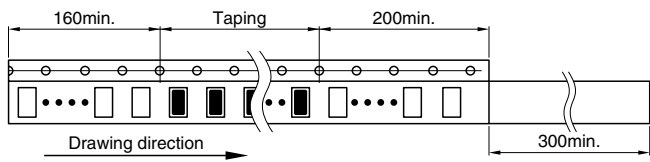
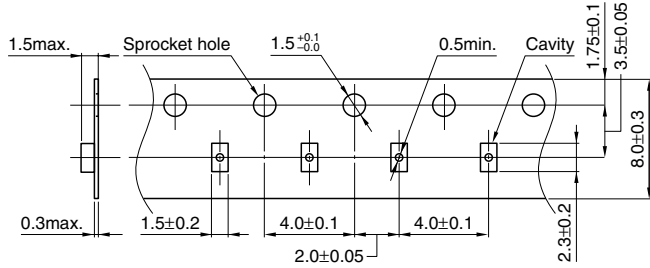

Dimensions in mm

• All specifications are subject to change without notice.