

PRODUCT NO.	APPEARANCE	COMPONENTS	FPC	EJECT	PACKAGING	MAIN BODY	REMARK
55640-10101(LF)	BLUE	N/A	52534-002(LF)	55644-001	340391-001	55641-001	
55640-20301(LF)	BLUE	N/A	10115336-001	55644-001	340391-101	55641-001	
55640-23201(LF)	BLUE	10018024-001	52534-004(LF)	55644-001	340391-201	55641-002	
55640-20201(LF)	BLUE	N/A	52534-004(LF)	55644-001	340391-201	55641-002	
55640-20202(LF)	BLUE	10062236-001	52534-004(LF)	55644-001	10062267-02-001	55641-002	
55640-23301(LF)	BLUE	10018024-001	52534-006(LF)	55644-001	340391-201	55641-002	
55640-20211(LF)	BLUE	N/A	52534-004(LF)	55644-002	340391-201	55641-003	FOR MOTOROLA
55640-30201(LF)	BLUE	N/A	10093563-001<FFC>	55644-002	340391-201	55641-002	FOR MITAC

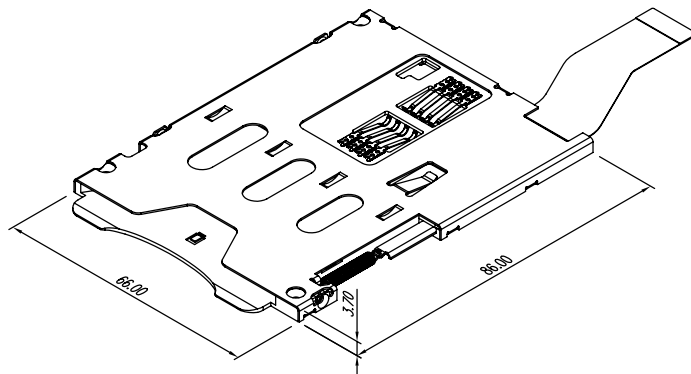

NOTE :

- SMART CARD READER FOR LOWER PROFILE HEIGHT OF 3.6 mm.
- TOTAL CIRCUIT RESISTANCE PER ONE LOOP SHALL NOT EXCEED 200 MILLIOHMS.
- THE INSERTION & EJECTING FORCE < 650g.
- MATERIALS :
CONTACTS : COPPER ALLOY, GOLD OVER NICKEL ON CONTACT AREA.
HOUSING : THERMOPLASTIC POLYCARBONATE.
COVER : STAINLESS STEEL.
- ENVIRONMENT :
STORAGE TEMPERATURE : FROM -40°C TO 85°C.
OPERATION TEMPERATURE : FROM -20°C TO 70°C.
- ORDER DATAS : 55640-X X X X X LF
 - LEAD FREE OPTION
 - PACKAGING
 - EJECT
 - FPC SHAPE
 - CUSTOMIZED COMPONENTS OPTIONS
 - GUIDE PLATE
- 7.IF LEAD FREE P/N, GS-14-920 SHOULD BE APPLIED.
- 8.THIS PRODUCT MEETS EUROPEAN UNION DIRECTIVES AND OTHER COUNTRY REGULATIONS AS DESCRIBED IN GS-22-008.



Copyright FCI.

rev	ecn no	dr	date
J	N08-0158	SH	08/01/08
K	N09-0283	SH	26/08/09
L	N10-0227	SH	19/07/10
-	-	-	-
-	-	-	-
-	-	-	-
-	-	-	-

www.fciconnect.com		surface 6.4/	tolerance std	projection	←→
		ISD 1302	ISD 406 ISD 110	⊕	
		TOLERANCES UNLESS OTHERWISE SPECIFIED		size A4	Scale 1.000
Dr	A JUANG	9/4/00	ANGULAR	0X ±0.3	ECN
Eng	MINERVA WANG	9/4/00	LINEAR	0XX ±0.15	Spec ref
Chr	JDESEPH HSIA	9/4/00	0° ±2°	0XXX ±0.05	
Appr	JENN TSAD	9/4/00	Product family		
FCI		title SMART PLUS B ASSEMBLY		dwg no 55640	Rev. L
catalog no		CUSTOMER		sheet 1 of 7	

3 PDM: Rev:L

STATUS:Released

4 Printed: Aug 06, 2010



Copyright FCI.

PRODUCT NO.
55640-10101(LF)

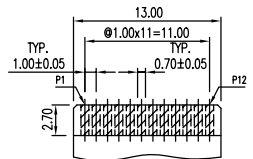
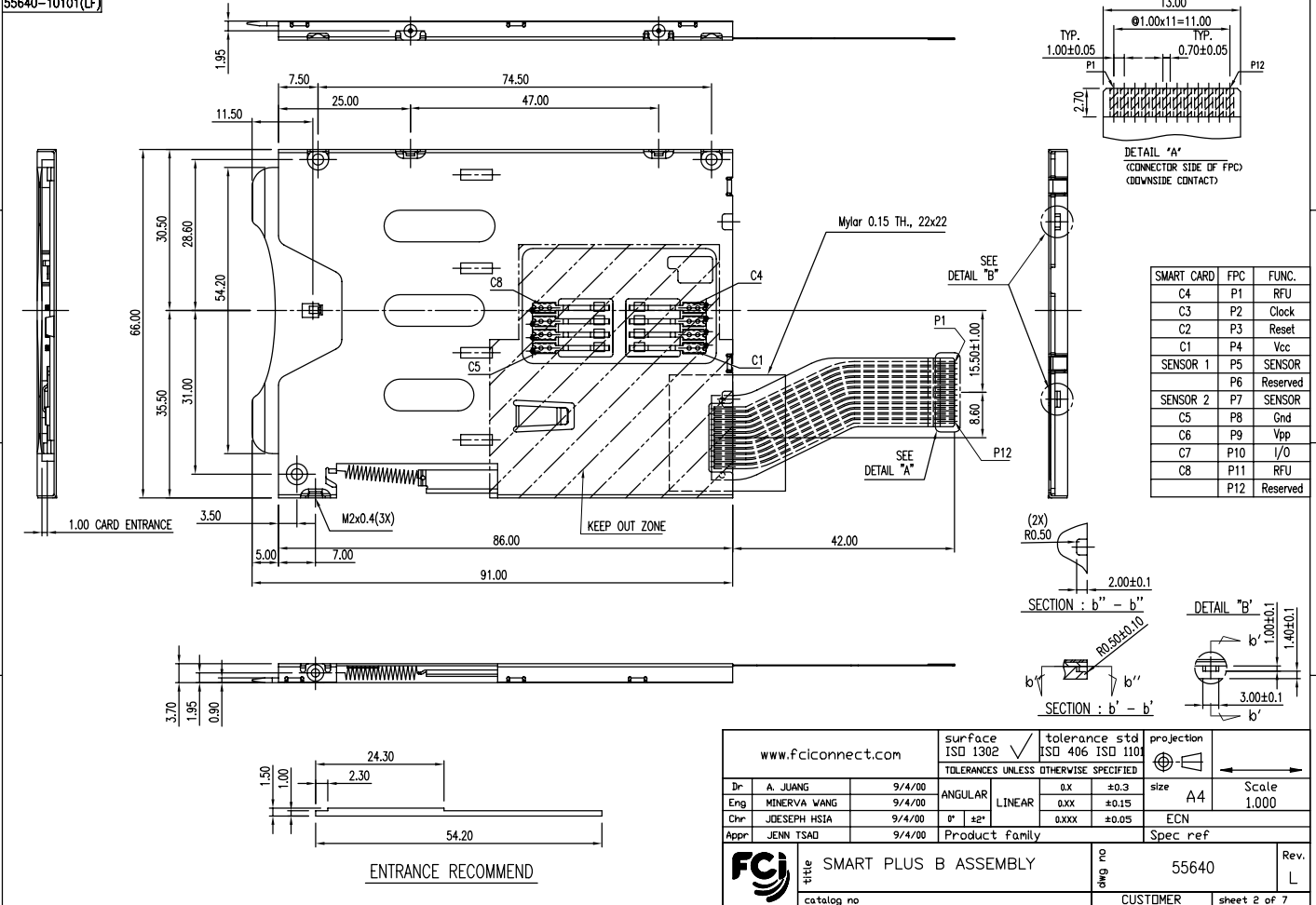

DETAIL "A"
(CONNECTOR SIDE OF FPC)
(DOWNSIDE CONTACT)

SMART CARD	FPC	FUNC.
C4	P1	RFU
C3	P2	Clock
C2	P3	Reset
C1	P4	Vcc
SENSOR 1	P5	SENSOR
	P6	Reserved
SENSOR 2	P7	SENSOR
C5	P8	Gnd
C6	P9	Vpp
C7	P10	I/O
C8	P11	RFU
	P12	Reserved

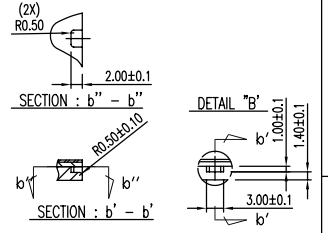

www.fciconnect.com		surface	tolerance std	projection
		ISO 1302	ISO 406 ISO 1101	ISO 10303-21
		TOLERANCES UNLESS OTHERWISE SPECIFIED		size A4
Dr	A. JUANG	9/4/00	ANGULAR	Scale 1.000
Eng	MINERVA WANG	9/4/00	LINEAR	
Chr	JOSEPH HSIA	9/4/00	0° ±2°	ECN
Appr	JENN TSAD	9/4/00	Product family	Spec ref
FCI title SMART PLUS B ASSEMBLY		ang no	55640	Rev. L
catalog no		CUSTOMER		sheet 2 of 7

REV F - 2006-06-17



Copyright FCI

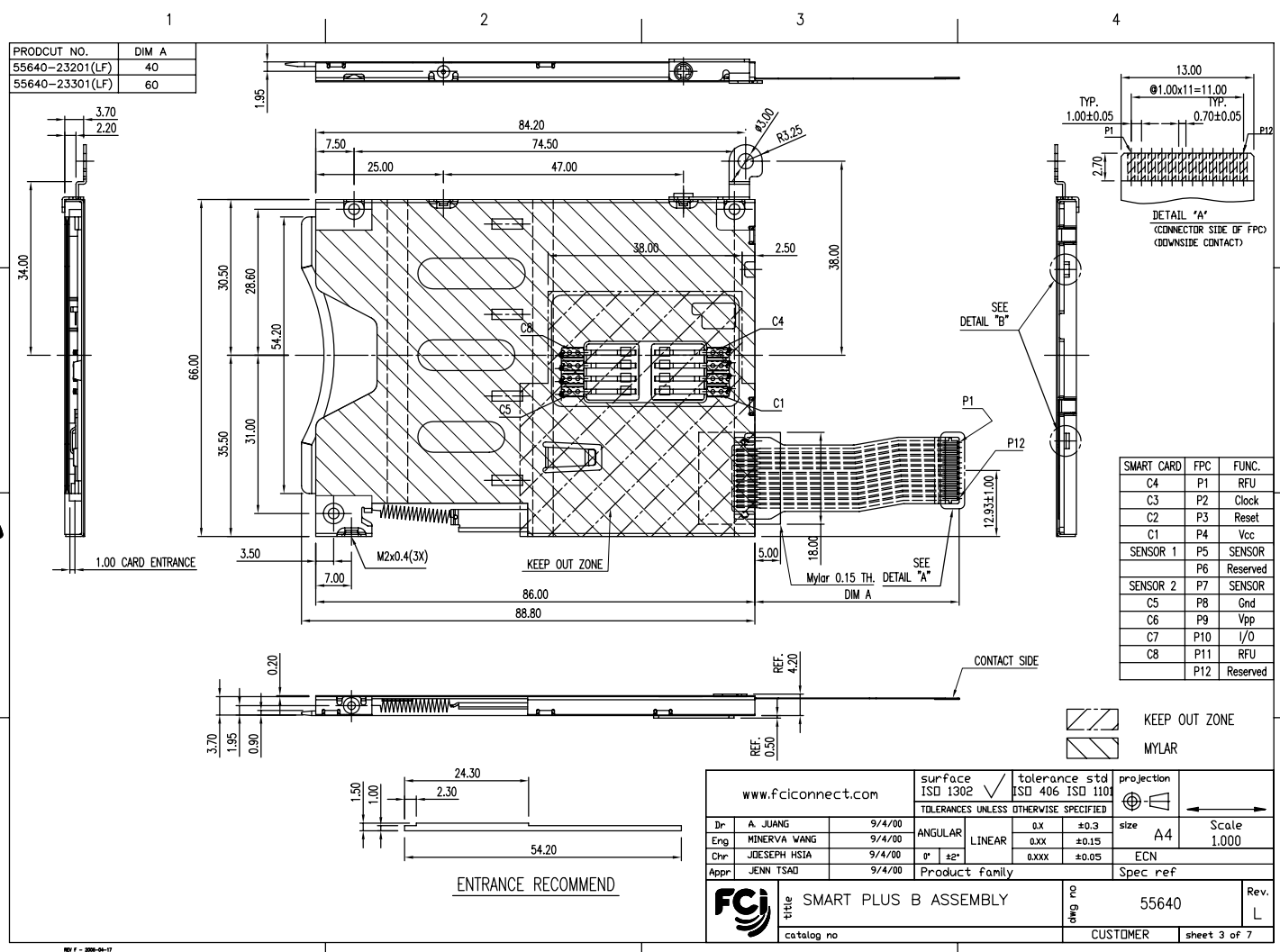



Copyright FCI.

PRODUCT NO.
55640-20201(LF)
55640-20211(LF)

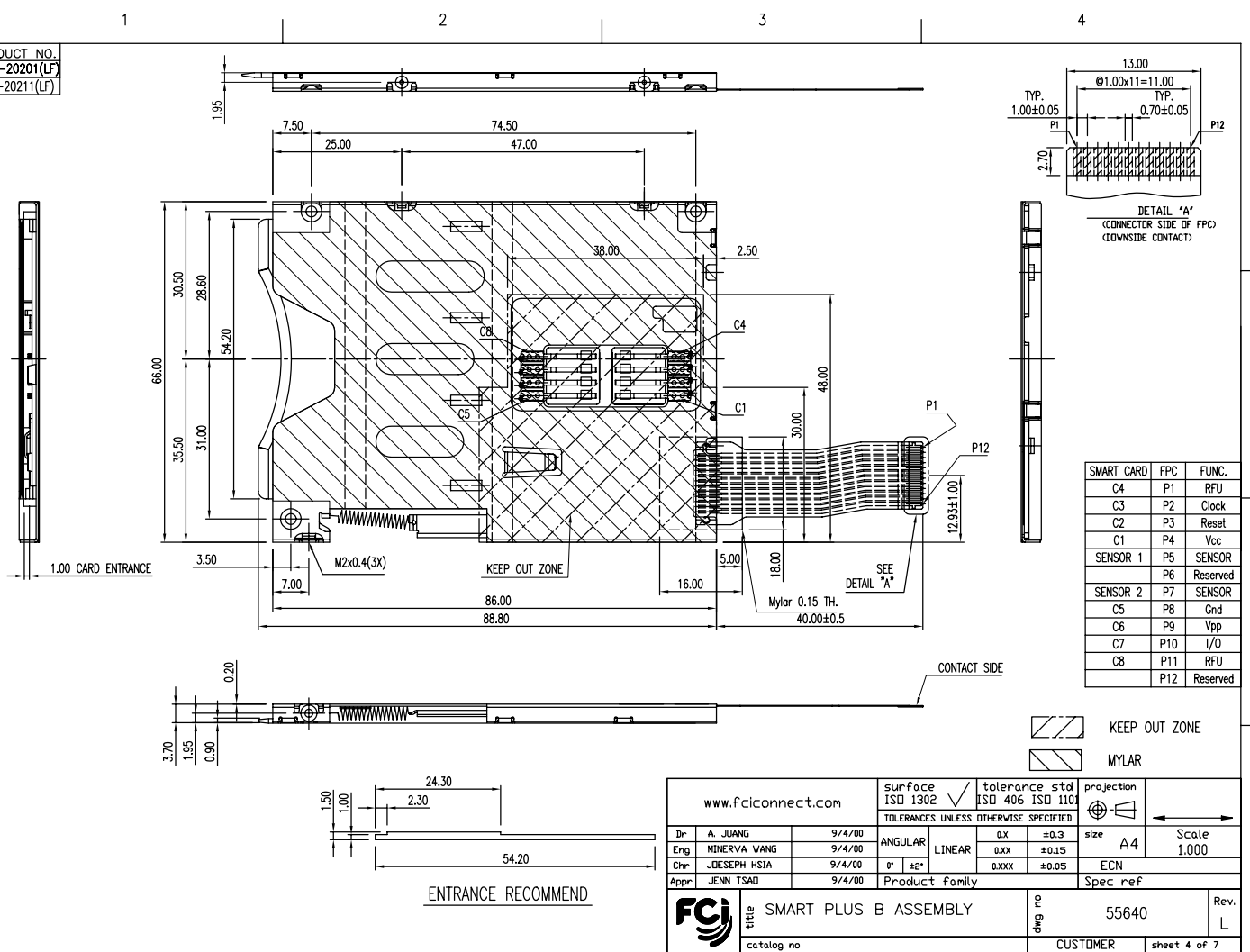

SMART CARD	FPC	FUNC.
C4	P1	RFU
C3	P2	Clock
C2	P3	Reset
C1	P4	Vcc
SENSOR 1	P5	SENSOR
	P6	Reserved
SENSOR 2	P7	SENSOR
C5	P8	Gnd
C6	P9	Vpp
C7	P10	I/O
C8	P11	RFU
	P12	Reserved

KEEP OUT ZONE
MYLAR

www.fciconnect.com		surface ISD 1302	tolerance std ISD 406 ISD 110	projection	
TOLERANCES UNLESS OTHERWISE SPECIFIED		ANGULAR	LINEAR	size A4	Scale 1,000
Dr A. JUANG	9/4/00	0.X	±0.3	ECN	
Eng MINERVA WANG	9/4/00	0.XX	±0.15	Spec ref	
Chr JOSEPH HSIA	9/4/00	0.XXX	±0.05		
Appr JENN TSAO	9/4/00	Product family			
FCI	title SMART PLUS B ASSEMBLY	ding no 55640	Rev. L		
catalog no	CUSTOMER	sheet 4 of 7			



Copyright FCI.

PRODUCT NO
55640-2020ELF

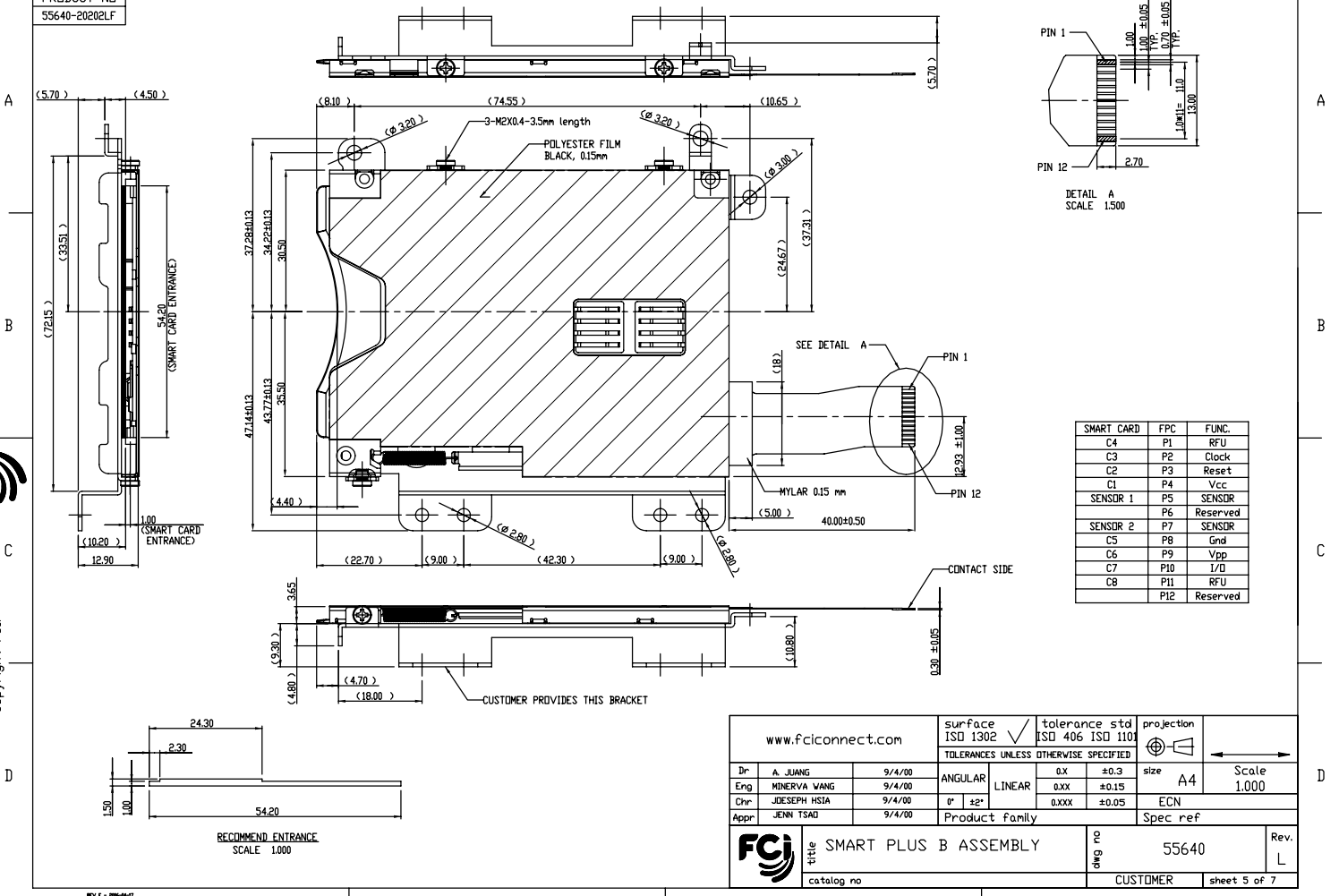

www.fciconnect.com		surface ISO 1302	tolerance std ISO 406 ISO 1101	projection A4	Scale 1,000
TOLERANCES UNLESS OTHERWISE SPECIFIED		ANGULAR	LINEAR	size	ECN
Dr	A. JUANG	9/4/00	0.X	±0.3	
Eng	MINERVA WANG	9/4/00	0.XX	±0.15	
Chr	JOSEPH HSIA	9/4/00	0.XXX	±0.05	
Appr	JENN TSAD	9/4/00	Product family		Spec ref
title SMART PLUS B ASSEMBLY		drawing no. 55640		Rev. L	
catalog no.		CUSTOMER		sheet 5 of 7	

PRODUCT NO.
55640-30201LF

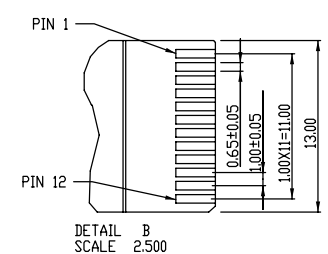
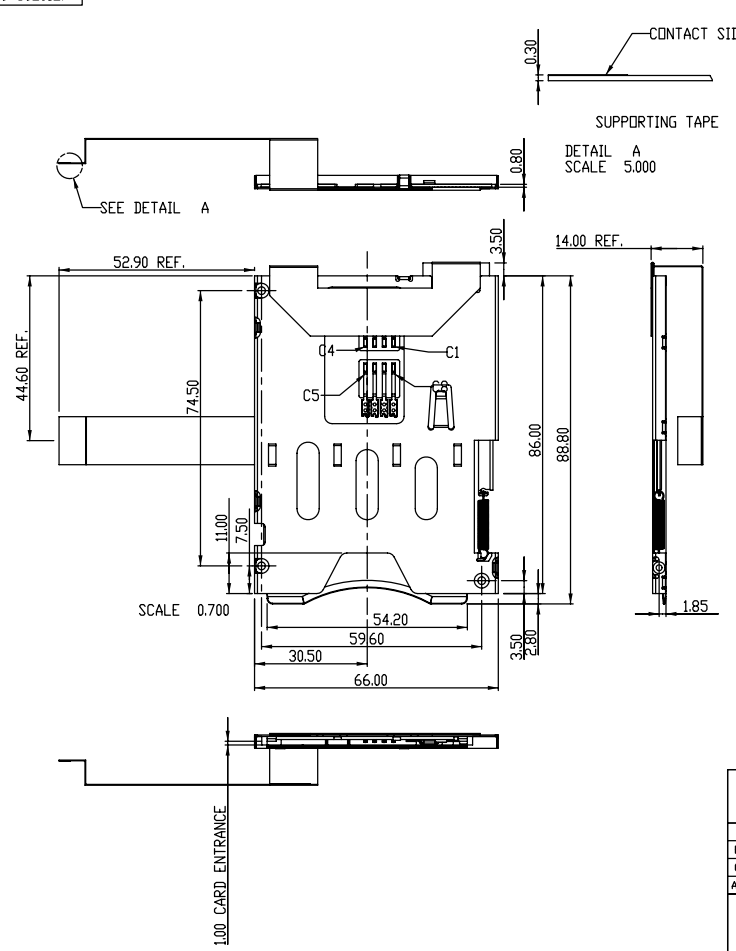

DETAIL A
SCALE 5.000

DETAIL B
SCALE 2.500

SMART CARD	FFC	FUNC.
C4	P1	RFU
C3	P2	CLOCK
C2	P3	RESET
C1	P4	VCC
SENSOR 1	P5	SENSOR
	P6	Reserved
SENSPR 2	P7	SENSOR
C5	P8	GND
C6	P9	VPP
C7	P10	I/O
C8	P11	RFU
	P12	Reserved

www.fciconnect.com		surface ISO 1302	tolerance std ISO 406 ISO 1101	projection ASME Y14.5
TOLERANCES UNLESS OTHERWISE SPECIFIED		ANGULAR	LINEAR	size A4 Scale 1.000
Dr	A. JIANG 9/4/00	0°	±0.3	ECN
Eng	MINERVA WANG 9/4/00	±0.15	±0.05	Product family
Chr	JOSEPH HSIA 9/4/00	±0.05	±0.05	Spec ref
Appr	JENI TSAD 9/4/00	Product family		title SMART PLUS B ASSEMBLY
catalog no		ang no	55640	Rev. L
CUSTOMER		sheet 6 of 7		



Copyright FCI.



Copyright FCI.

PRODUCT NUMBER
55640-20301LF

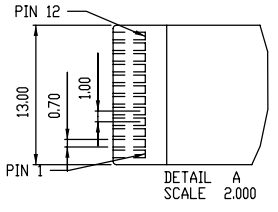
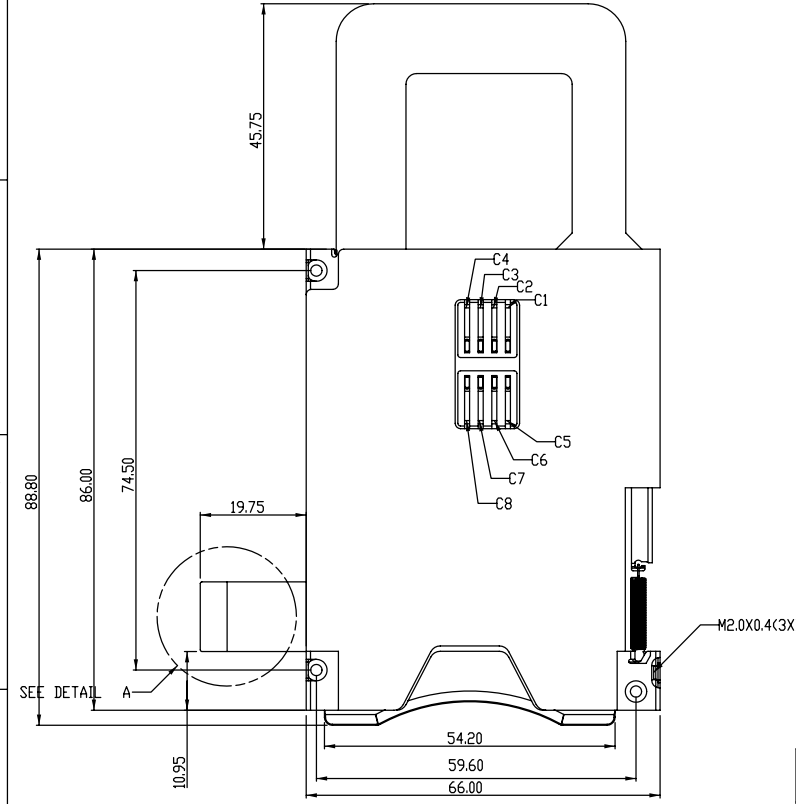

SMART CARD	FPC	FUNC.
C4	P1	RFU 4
C3	P2	CLOCK
C2	P3	RESET
C1	P4	Vcc
SENSOR 1	P5	SENSOR
	P6	RESERVED
SENSOR 2	P7	SENSOR
C5	P8	Gnd
C6	P9	Vpp
C7	P10	I/O
C8	P11	RFU 8
	P12	RESERVED

NOTE:
1. Material:
METAL SHELL: STAINLESS STEEL, T=0.40mm
PCB: FR-4, T=0.80mm
TERMINAL: PHOSPHOR BRONZE.
PLATING SPEC AS BELOW:
ALL OVER NICKEL UNDERPLATING
PURE TIN PLATING ON CONTACT SURFACE.
AND SOLDER TAIL.
2. CARD DETECTION SWITCH NORMALLY OPEN WITHOUT MATING CARD

www.fciconnect.com			surface	tolerance std	projection	
			ANGULAR	LINEAR	size	Scale
Dr	A. JUANG	9/4/00	0.X	±0.3	A4	1,000
Eng	MINERVA WANG	9/4/00	0.XX	±0.15		
Chr	JOSEPH HSIA	9/4/00	0.XXX	±0.05	ECN	
Appr	JENN TSAO	9/4/00	Product family		Spec ref	
title		SMART PLUS B ASSEMBLY		chg no	55640	Rev.
catalog no				CUSTOMER	sheet 7 of 7	L

REV 7 - 000-04-07