

Tous droits strictement réservés. Reproduction ou communication à des tiers interdite sous quelque forme que ce soit sans autorisation écrite du propriétaire. Propriété de c FCI. Droits de reproduction FCI.

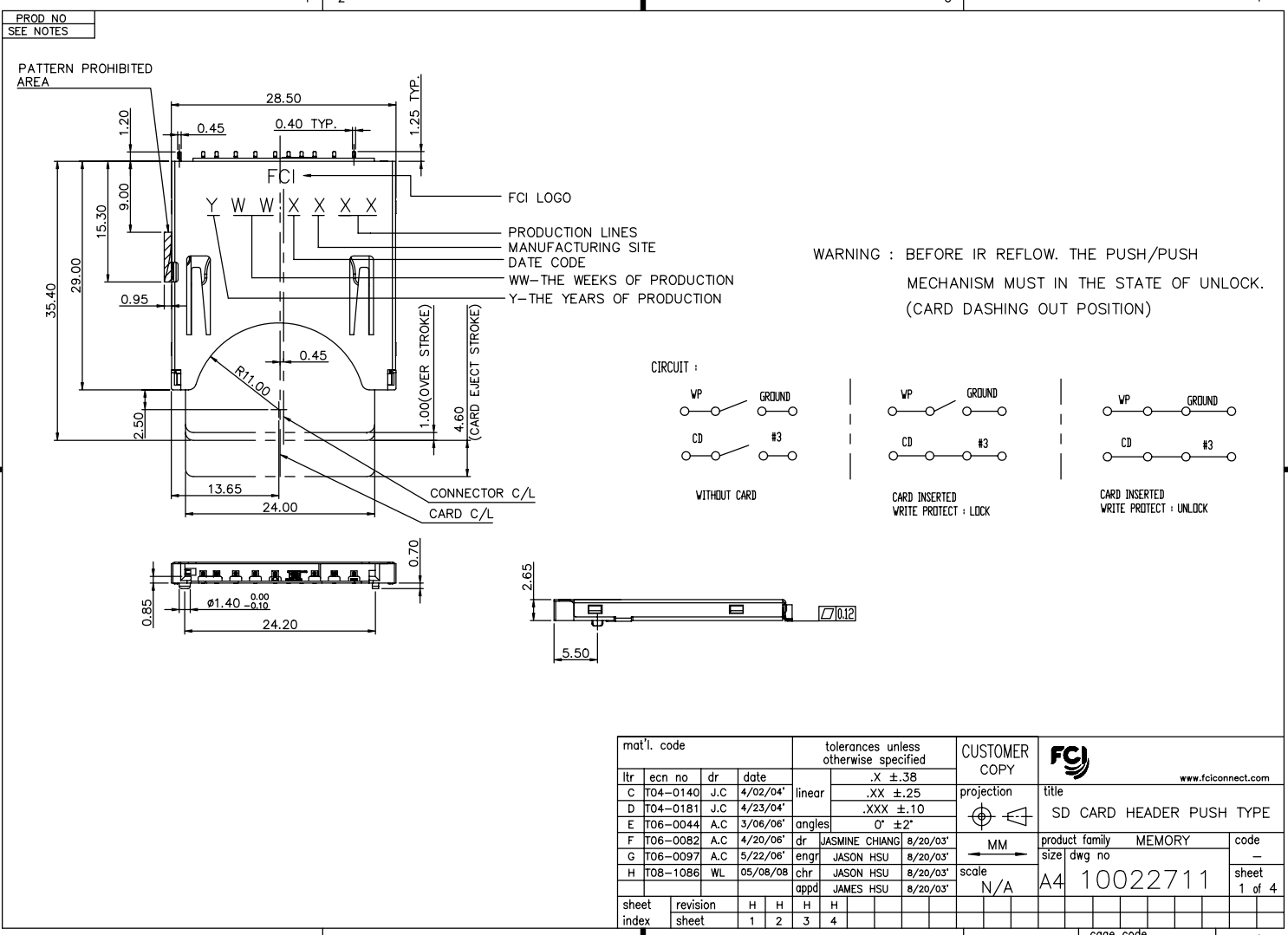

All rights strictly reserved. Reproduction or issue to third parties in any form whatever is not permitted without written authority from the proprietor. Property of FCI. Copyright FCI.



1 | 2 | 3 | 4

PROD NO  
SEE NOTES

WARNING : BEFORE IR REFLOW. THE PUSH/PUSH MECHANISM MUST IN THE STATE OF UNLOCK. (CARD DASHING OUT POSITION)

CIRCUIT :

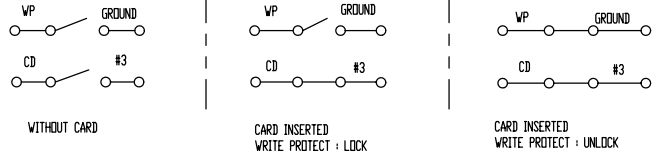

| mat'l. code |                |     |          | tolerances unless otherwise specified |                         | CUSTOMER COPY  | FCI                |
|-------------|----------------|-----|----------|---------------------------------------|-------------------------|----------------|--------------------|
| C           | T04-0140       | J.C | 4/02/04' | linear                                | .X ±.38                 | projection     | www.fciconnect.com |
| D           | T04-0181       | J.C | 4/23/04' |                                       | .XX ±.25                |                |                    |
| E           | T06-0044       | A.C | 3/06/06' | angles                                | .XXX ±.10               |                |                    |
| F           | T06-0082       | A.C | 4/20/06' | dr                                    | 0' ±2'                  |                |                    |
| G           | T06-0097       | A.C | 5/22/06' | enrg                                  | JASMINE CHIANG 8/20/03' | product family | MEMORY             |
| H           | T08-1086       | WL  | 05/08/08 | chr                                   | JASON HSU 8/20/03'      | size           | dwg no             |
|             |                |     |          | appd                                  | JAMES HSU 8/20/03'      | scale          | A4 10022711        |
| sheet index | revision sheet | H   | H        | H                                     | H                       |                | code               |
|             |                | 1   | 2        | 3                                     | 4                       |                | 225026             |

1 | 2 | 3 | 4

PDM: Rev:H STATUS Released 225026: Oct 10, 2008

Tous droits strictement réservés. Reproduction ou communication à des tiers interdite sous quelque forme que ce soit sans autorisation écrite du propriétaire. Property of FCJ. Droits de reproduction FCJ.



All rights strictly reserved. Reproduction or issue to third parties in any form whatsoever is not permitted without written authority from the proprietor. Property of FCJ. Copyright FCJ.

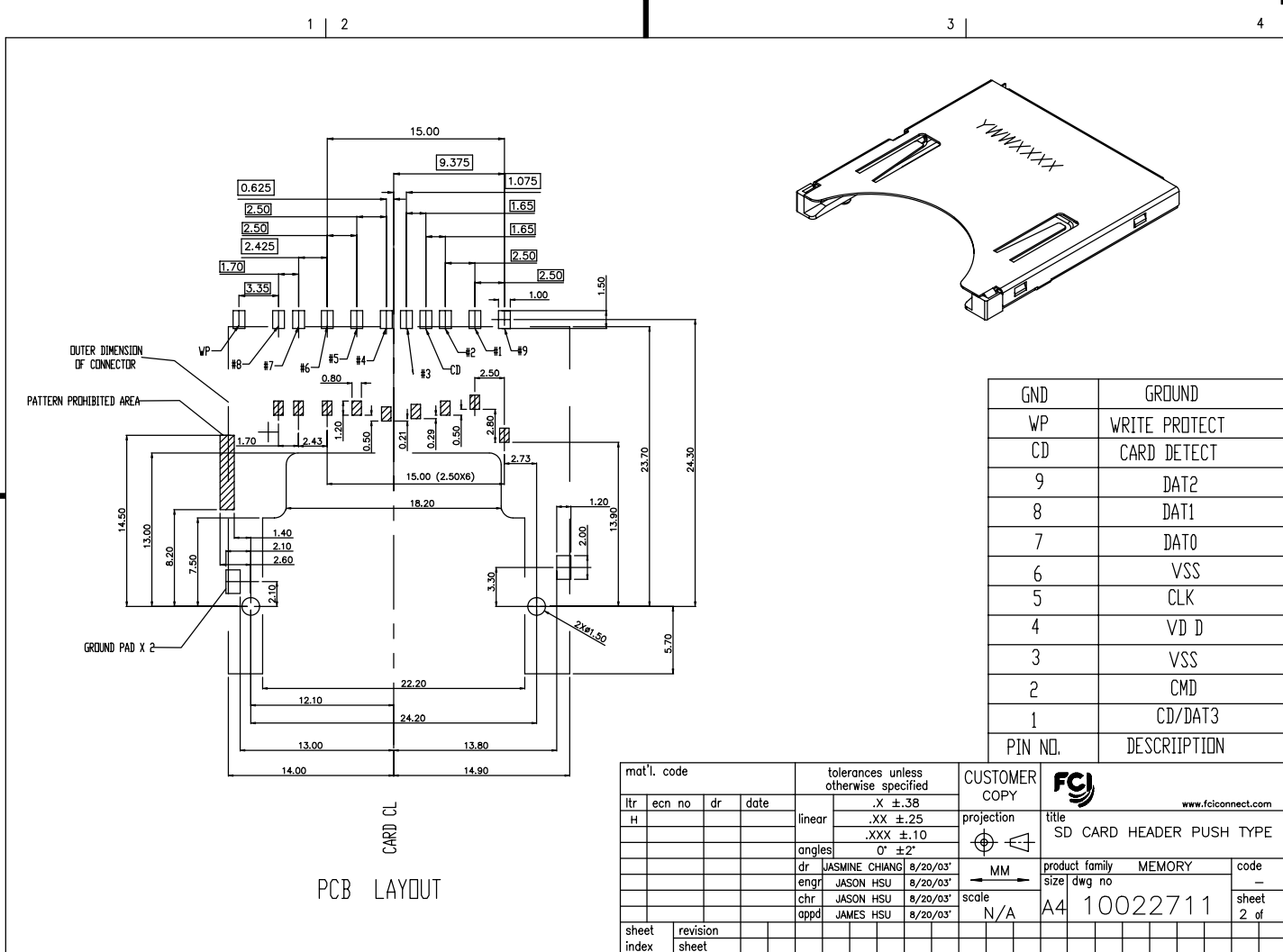

| PIN NO. | DESCRIPTION   |
|---------|---------------|
| GND     | GROUND        |
| WP      | WRITE PROTECT |
| CD      | CARD DETECT   |
| 9       | DAT2          |
| 8       | DAT1          |
| 7       | DAT0          |
| 6       | VSS           |
| 5       | CLK           |
| 4       | VD D          |
| 3       | VSS           |
| 2       | CMD           |
| 1       | CD/DAT3       |

|             |                |                                       |      |               |                         |            |                          |             |             |
|-------------|----------------|---------------------------------------|------|---------------|-------------------------|------------|--------------------------|-------------|-------------|
| mat'l. code |                | tolerances unless otherwise specified |      | CUSTOMER COPY |                         | FCJ        |                          |             |             |
| ltr         | ecn no         | dr                                    | date | linear        | .X ±.38                 | projection | title                    |             |             |
| H           |                |                                       |      |               | .XX ±.25                |            | SD CARD HEADER PUSH TYPE |             |             |
|             |                |                                       |      |               | .XXX ±.10               |            |                          |             |             |
|             |                |                                       |      | angles        | 0° ±2°                  |            | product family MEMORY    |             |             |
|             |                |                                       |      | dr            | JASMINE CHIANG 8/20/03' |            |                          | size dwg no |             |
|             |                |                                       |      | enrg          | JASON HSU 8/20/03'      |            |                          |             | A4 10022711 |
|             |                |                                       |      | chr           | JASON HSU 8/20/03'      |            |                          |             |             |
|             |                |                                       |      | appd          | JAMES HSU 8/20/03'      | scale      | N/A                      |             |             |
| sheet index | revision sheet |                                       |      |               |                         |            |                          |             |             |

ACAD

PDM: Rev:H

STATUS Released

Printed: Oct 10, 2006

cage code 22526

Tous droits strictement réservés. Reproduction ou communication a des tiers interdite sous quelque forme que ce soit sans autorisation écrite du propriétaire. Propriété de c FCI. Droits de reproduction FCI.

All rights strictly reserved. Reproduction or issue to third parties in any form whatever is not permitted without written authority from the proprietor. Property of FCI. Copyright FCI.

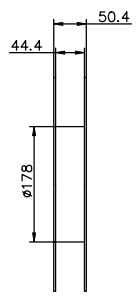
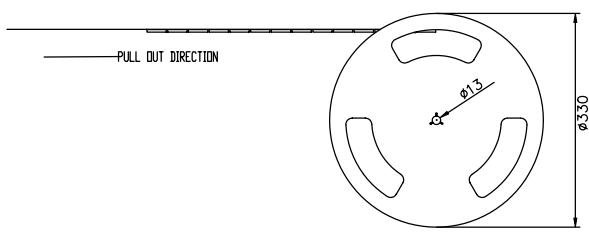
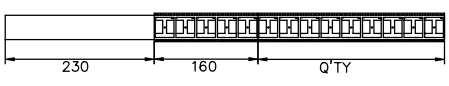
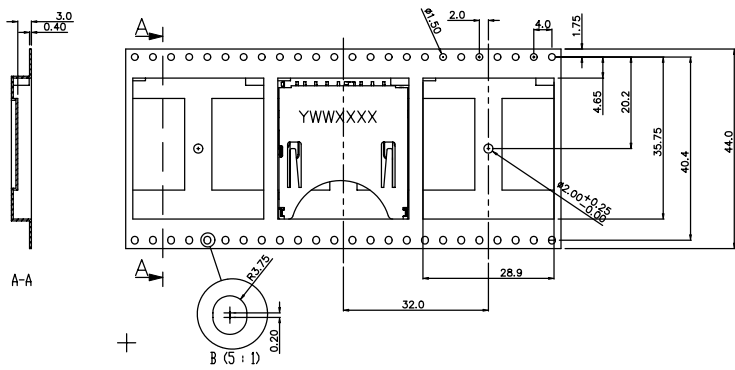

NOTES :  
 1. MATERIAL :  
 CARRIER TAPE: POLYSTYRENE , COLOR : BLACK  
 COVER TAPE : POLYSTYRENE , COLOR : TRANSPARENT  
 PLASTIC RELL : POLYSTYRENE , COLOR : BLUE  
 2. QUANTITY : 300PCS/REEL

|             |                |    |      |                                       |                         |               |                                |          |      |                    |  |
|-------------|----------------|----|------|---------------------------------------|-------------------------|---------------|--------------------------------|----------|------|--------------------|--|
| mat'l. code |                |    |      | tolerances unless otherwise specified |                         | CUSTOMER COPY |                                | FCI      |      | www.fciconnect.com |  |
| ltr         | ecn no         | dr | date | linear                                | .X ±.38                 | projection    | title SD CARD HEADER PUSH TYPE |          |      |                    |  |
| H           |                |    |      |                                       | .XX ±.25                |               |                                |          |      |                    |  |
|             |                |    |      | angles                                | .XXX ±.10               |               |                                |          |      |                    |  |
|             |                |    |      |                                       | 0' ±2'                  |               |                                |          |      |                    |  |
|             |                |    |      | dr                                    | JASMINE CHIANG 8/20/03' |               | product family MEMORY          |          | code |                    |  |
|             |                |    |      | enr                                   | JASON HSU 8/20/03'      | size          |                                | dwg no   |      | sheet              |  |
|             |                |    |      | chr                                   | JASON HSU 8/20/03'      | A4            |                                | 10022711 |      | 3 of               |  |
|             |                |    |      | appd                                  | JAMES HSU 8/20/03'      | N/A           |                                |          |      |                    |  |
| sheet index | revision sheet |    |      |                                       |                         |               |                                |          |      |                    |  |

ACAD PDM: Rev:H 3 STATUS Released 2008 Oct 10, 2008 cage code 20526 4

NOTES :

1. MATERIAL :

INSULATOR : UL 94V-0, LCP+30%G/F, COLOR : BLACK  
 SIGNAL CONTACTS : PHOSPHOR BRONZE, C5210R-SH.  
 CD/WP CONTACTS : Ti-Cu, TICUR1-M-EH.  
 SHIELD: STAINLESS STEEL SUS-301.

2. PLATING SPEC:

CONTACT: 50u" Min NICKEL UNDERPLATED ALL OVER,  
 100u" Min TIN/LEAD OR MATTE TIN ON SOLDER TAIL AREA,  
 SELECTIVE GOLD PLATED ON CONTACT AREA.

3. PRODUCT SPECIFICATION: GS-12-241.

4. PACKAGING SPECIFICATION: GS-14-851.

5. CARD PULLING-OUT FORCE EXCEED 0.36KGF(3.5N)  
 UNDER LOCKING-CONDITION.

6. MULTIMEDIA CARD COMPATIBLE.

7. WP: WRITE PROTECT

CD: CARD DETECT INDICATION

8. LEAD FREE NOTES:

- 8.1. THE HOUSING WILL WITHSTAND EXPOSURE TO 260°C PEAK TEMPERATURE FOR 10 SECONDS IN A CONVECTION, IR OR VAPOR PHASE REFLOW OVEN.
- 8.2. THIS PRODUCT (10022711-00XXLF) MEETS THE EUROPEAN UNION DIRECTIVE AS DESCRIBED IN GS-22-008.

9. PART NUMBER DESCRIPTIONS:

10022711- 0 0 X X X

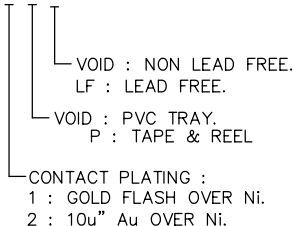

Tous droits strictement reserves. Reproduction ou communication a des tiers interdite sous quelque forme que ce soit sans autorisation écrite du propriétaire. Propriete de c FCI. Droits de reproduction FCI.



All rights strictly reserved. Reproduction or issue to third parties in any form whatever is not permitted without written authority from the proprietor. Property of FCI. Copyright FCI.

|             |                |    |      |                                       |                |          |  |               |            |                          |                |                    |        |  |
|-------------|----------------|----|------|---------------------------------------|----------------|----------|--|---------------|------------|--------------------------|----------------|--------------------|--------|--|
| mat'l. code |                |    |      | tolerances unless otherwise specified |                |          |  | CUSTOMER COPY |            | FCI                      |                | www.fciconnect.com |        |  |
| ltr         | ecn no         | dr | date | linear                                | .X ±.38        |          |  |               | projection | SD CARD HEADER PUSH TYPE |                |                    |        |  |
| H           |                |    |      |                                       | .XX ±.25       |          |  |               |            | MM                       | product family |                    | MEMORY |  |
|             |                |    |      |                                       | .XXX ±.10      |          |  |               |            |                          | size           |                    | dwg no |  |
|             |                |    |      | angles                                | 0° ±2°         |          |  |               | scale      | A4                       |                | 10022711           |        |  |
|             |                |    |      | dr                                    | JASMINE CHIANG | 8/20/03' |  |               |            |                          |                |                    |        |  |
|             |                |    |      | engr                                  | JASON HSU      | 8/20/03' |  |               |            |                          |                |                    |        |  |
|             |                |    |      | chr                                   | JASON HSU      | 8/20/03' |  |               |            |                          |                |                    |        |  |
|             |                |    |      | appd                                  | JAMES HSU      | 8/20/03' |  |               |            |                          |                |                    |        |  |
| sheet index | revision sheet |    |      |                                       |                |          |  |               |            | cage code                |                | 22526              |        |  |