

CCM03 MK II with Auto Lock cover



A new range of CCM03 connectors have been developed to interface with SIM/SAM cards as defined by GSM11-11 and ENV1375-1. The connectors are available with a hinged metallic cover and have been designed to provide an easier open/lock function and side card entry.

Features

- Available with 6 cross contacts which are designed to give a consistently reliable normal force over the life of the connector.
- The hinged metallic cover can automatically lock by pressure.
- Side entry of the card ensures easier positioning of the card into the connector.
- Insulated blade switch version available for detection card when cover is closed.
- The molding is polarized so that the cover can only be closed if the card is correctly inserted.
- Inspection slots allow an electrical test to be made without opening the cover.
- With tape and reel packaging as standard, the connectors are designed to be automatically pick-and-placed.
- The moldings are made from high-temperature thermoplastics suited to infrared and convection soldering processes.
- Robustly formed printed circuit tails allow a coplanarity of $\pm 0,05$ mm to be maintained.

Construction

Contacts	Copper alloy
Contacts finish	Gold over nickel
PC tail plating	Tin lead (2 μ min)
Molding	High temp. thermoplastic, UL94V-0
Cover	Stainless steel

Mechanical Data

Number of Contacts	6
Mechanical life	10,000 cycles min
Contact force	0.35 N min / 0.50 N max
Vibration	Frequency 10 to 500 Hz. Acceleration 50m/s ² Duration 6 hours - amplitude 0.35 mm (0.014) Max electrical discontinuity 1 μ s

Contact Electrical Data

Insulation resistance	1,000 M Ω min
Resistance	100 m Ω max
Current rating	10 μ A min / 1 A max
Dielectric strength	750 Vrms min

Switch Electrical Data

Card detection switch	Normally open
Contact resistance	100 m Ω max
Dielectric strength	250 Vrms min
Current rating	1mA min / 10m A max
Maximum power	0.2 VA

Environmental Data

Operating temperature	-40°C to +85°C
Soldering temperature	Temperature/time profile acc. to CECC00802 para. 6.1, Fig. 3 with peak temperature 250°C
Damp heat	IEC 512 test number 11c (10 days)
Salt mist	IEC 512 test number 11f (96 hours)

Ordering Code

Part Number	Number of Contacts	Cover	Card Presence Switch	Quantity per reel
CCM03-3517	6	Side Hinged	No	1300
CCM03-3518	6	Front Hinged	Yes (insulated)	1300
CCM03-3529	6	Front Hinged	No	1300

Packaging

5 reels per box.



Dimensions are shown in mm
Specifications and dimensions subject to change

www.ck-components.com

CCM03 MK II with Auto Lock cover

Dimensional Drawings

Hinged Cover CCM03 - 3517 (6 contacts)

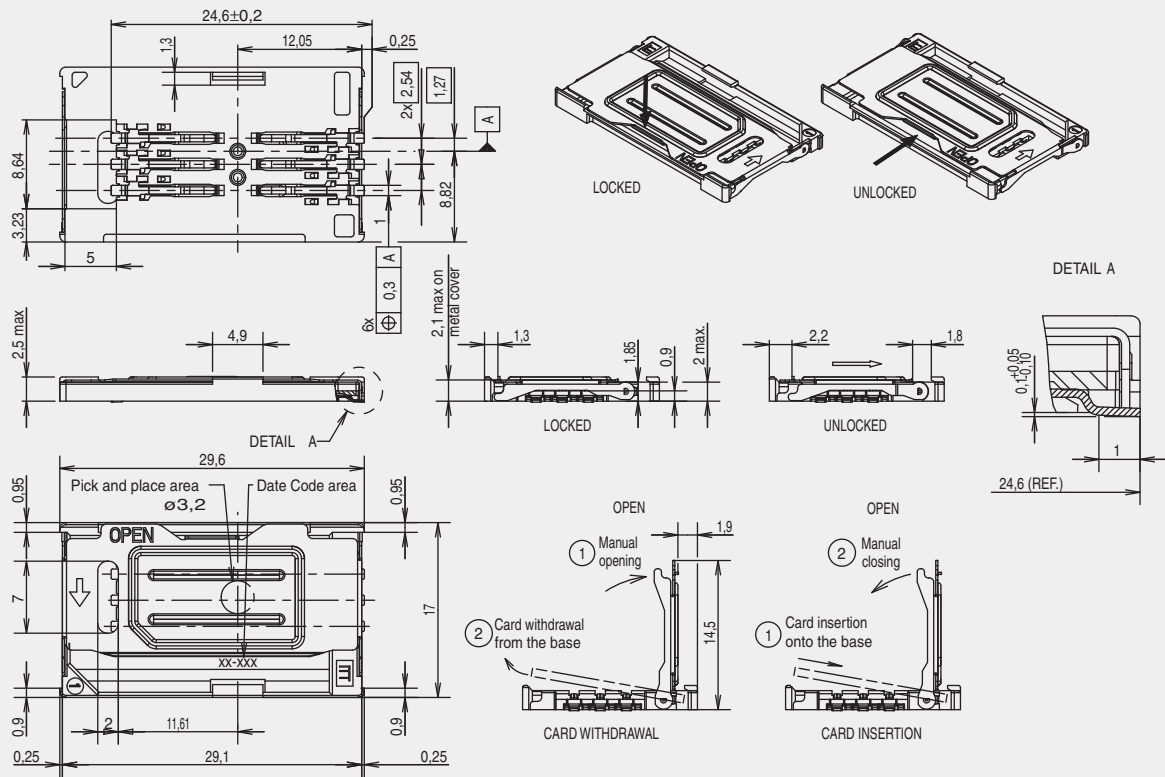

Note: Coplanarity of soldering surfaces: $\pm 0,05$ mm

PCB Layout

CCM03 - 3517 (6 contacts)

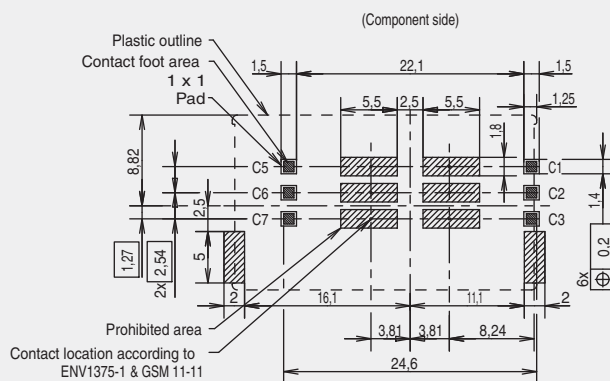

Unless otherwise stated, tolerances are $\pm 0,10$ mm



Dimensions are shown in mm
Specifications and dimensions subject to change

www.ck-components.com

CCM03 MK II with Auto Lock cover

Dimensional Drawings

Hinged Cover CCM03 - 3518 (6 contacts and switch)

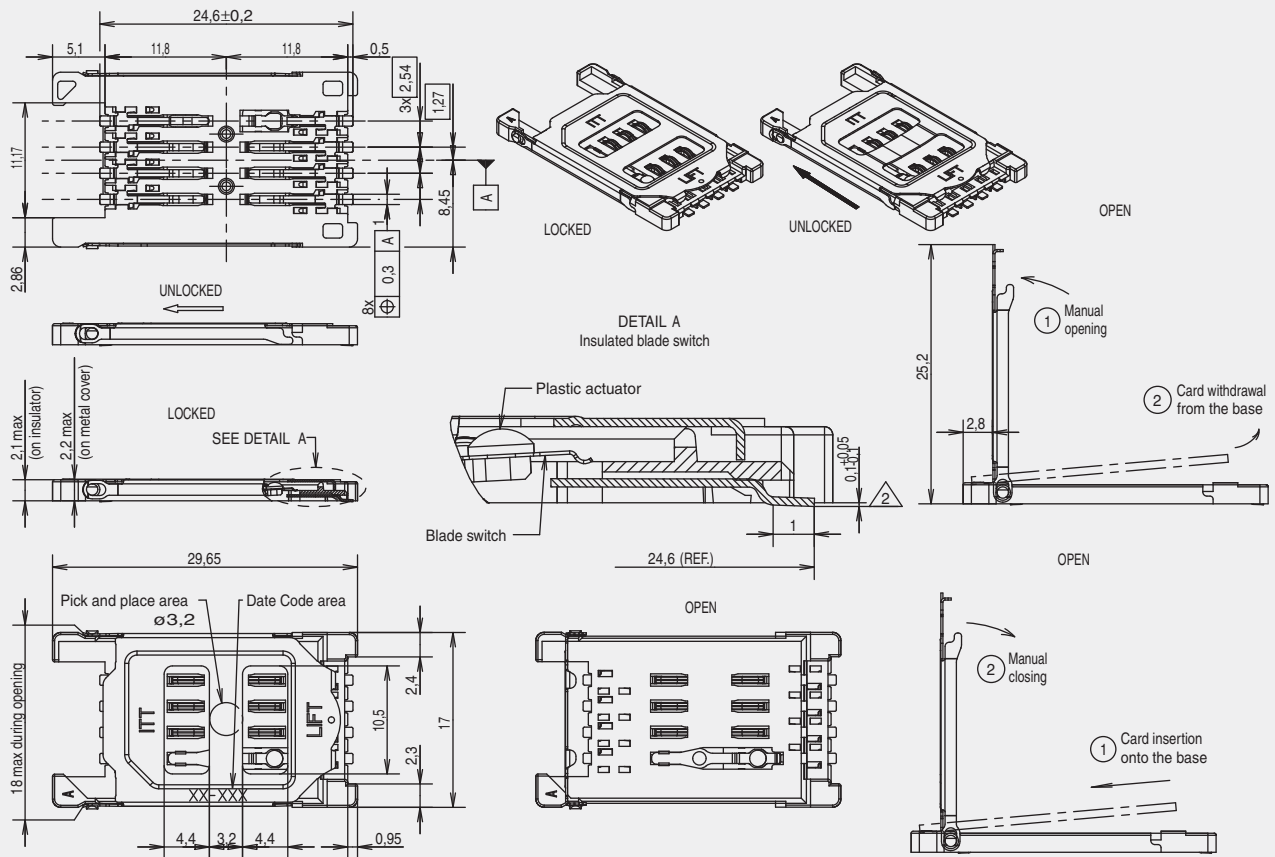

Note: Coplanarity of soldering surfaces: ± 0,05 mm

PCB Layout

CCM03 - 3518 (6 contacts and switch) CCM03-3529 (without switch) layout is similar except SW pads

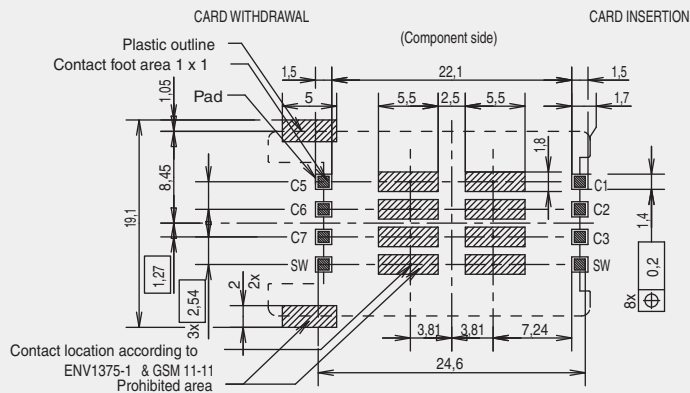

Unless otherwise stated, tolerances are ± 0,10 mm



Dimensions are shown in mm
Specifications and dimensions subject to change

www.ck-components.com