

PIN NUMBER	DIM. L
25,26	3.50
ALL OTHER PINS	4.25
1, 13, 38, 50	5.00

NOTES :

- MATERIAL :
INSULATOR : HIGH TEMPERATURE THERMOPLASTIC
FLAMMABILITY RATING: UL94V-0
COLOR: IVORY
CONTACT : COPPER ALLOY
GROUND MOUNTING EAR: COPPER ALLOY
- PLATING :
CONTACT AREA: SELECTIVE GOLD (SEE P/N DESCRIPTION)
UNDER PLATING: 50u" NICKEL OVERALL
SOLDER TAIL AREA: 100u" TIN/LEAD OR 100u" MATTE TIN
GROUND MOUNT EAR AREA: 100u" TIN/LEAD OR 100u" MATTE TIN
- SOLDERTAILS TO BE WITHIN 0.05 UPWARD AND 0.2 DOWNWARD FROM Z-DATUM PLACE, AND COPLANARITY OF SOLDER TAILS TO BE WITHIN 0.10mm.
- PRODUCT SPEC: GS-12-240.
- PACKAGING SPEC: GS-14-980.

mat'l. code				tolerances unless otherwise specified		CUSTOMER COPY	FCJ	
ltr	ecn no	dr	date	linear	.X ± 0.30	projection	www.fciconnect.com	
A	T04-0429	A.C	12/16/04		.XX ± 0.20		title	
B	T05-0256	A.C	11/09/05		.XXX ± 0.10		CF HEADER TYPE II NORMAL	
C	T06-0172	A.C	10/09/06	angles	0° ± 2°		S/O=0.0MM	
D	T09-1097	S.LIN	07/09/09	dr	ALLEN CHANG 12/16/04		product family	CF
E	T09-1113	S.LIN	09/03/09	engr	ALLEN CHANG 12/16/04	MM	size	TWN
F	T09-1144	S.LIN	11/27/09	chr	STERLING LIN 12/16/04	scale	NA	dwg no
				appd	H.C LIU 12/16/04	A4	10044078	sheet
sheet index	revision sheet	F	F					1 of 2
		1	2					

ACAD PDM: Rev:F STATUS: Released cage code Printed: Dec 01, 2009

Tous droits strictement réservés. Reproduction ou communication à des tiers interdite sous quelque forme que ce soit sans autorisation écrite du propriétaire. Propriété de c FCI. Droits de reproduction FCI.



All rights strictly reserved. Reproduction or issue to third parties in any form whatever is not permitted without written authority from the proprietor. Property of FCI. Copyright FCI.

Tous droits strictement réservés. Reproduction ou communication à des tiers interdite sous quelque forme que ce soit sans autorisation écrite du propriétaire. Propriété de c FCI. Droits de reproduction FCI.



All rights strictly reserved. Reproduction or issue to third parties in any form whatever is not permitted without written authority from the proprietor. Property of FCI. Copyright FCI.

6. Part Number Description:

P/N: 10044078-XX50XX

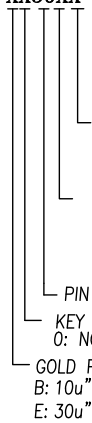

PLATING ON SOLDER TAIL AREA:
 BLANK: 100u" TIN/LEAD.
 LF: 100u" MATTE TIN.

BLANK: WITHOUT CAP+TRAY PACKING
 2: WITH CAP+TRAY PACKING
 3: WITH CAP+T&R PACKING

PIN COUNT.
 KEY TYPE:
 0: NORMAL TYPE
 GOLD PLATING:
 B: 10u" GOLD PLATE
 E: 30u" GOLD PLATE

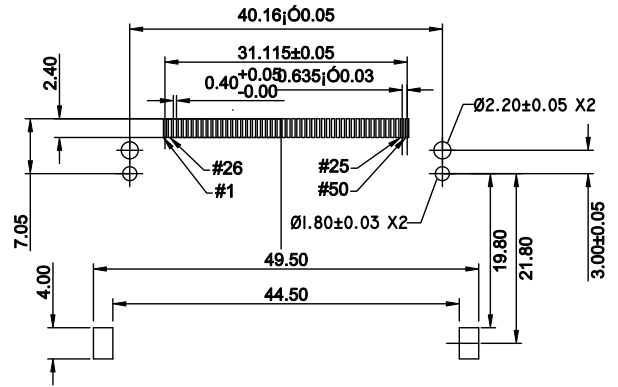

General Tolerance +/-0.05mm
 Recommended PCB Pattern

7. THE HOUSING WILL WITHSTAND EXPOSURE TO 260°C PEAK TEMPERATURE FOR 10 SECONDS IN A CONVECTION, IR OR VAPER PHASE REFLOW OVEN.
8. THIS PRODUCT (10053867-XXXXXLF) MEETS THE EUROPEAN UNION DIRECTIVE AS DESCRIBED IN GS-22-008.

mat'l. code				tolerances unless otherwise specified		CUSTOMER COPY		FCI		www.fciconnect.com	
ltr	ecn no	dr	date	linear	.X ± 0.30	projection	title				
F	-	-	-		.XX ± 0.20		CF HEADER TYPE II NORMAL				
				angles	.XXX ± 0.10		S/O=0.0MM				
					0° ±2'		product family		CF		
				dr	ALLEN CHANG 12/16/04	MM	size		dwg no		
				engr	ALLEN CHANG 12/16/04	NA	scale		A4 10044078		
				chr	STERLING LIN 12/16/04				code		
				appd	H.C LIU 12/16/04				TWN		
sheet index	revision sheet										sheet 2 of 2