

MEMORY CARD CONNECTORS (PCMCIA CONFORMABLE) CARDBUS

560H SERIES

■ FEATURES

- The connectors conform to the Japan Electronic Industry Development Association (JEIDA) and Personal Computer Memory Card International Association (PCMCIA) standards Ver. 4. for Cardbus
- Contact pitch of 1.27 mm (0.050 in.) x 1.27 mm (0.050 in.). Incorrect insertion is prevented. Hot system plugging is possible (contact detection).
- Plugs have an easy-to-use ejection mechanism.
- Raised mounting type connectors (under which components can be mounted) and low-profile connectors are available.
- Connectors accept Type I, II, and III cards.

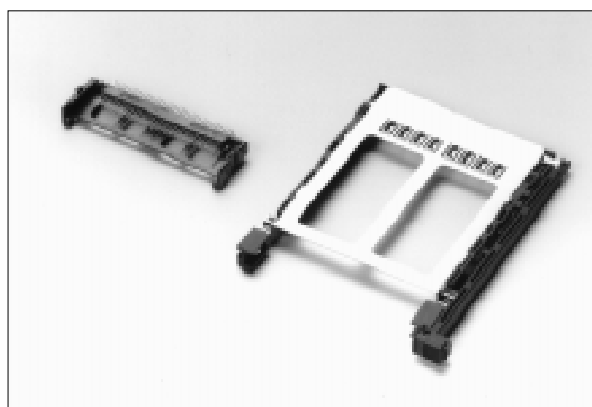

■ SPECIFICATIONS

Item	Specification
Operating temperature range	- 55°C to + 85°C
Current rating	DC 0.5 A
Voltage rating	AC 250 V
Contact resistance	40 mΩ max (6 VDC, 0.1 A)
Insulation resistance	1000 MΩ min. (500 VDC)
Dielectric withstanding voltage	500 VAC for 1 minute
Insertion/withdrawal life	Industrial environment: 5,000 times Office environment: 10,000 times

■ PIN CONNECTOR (PLUG) CONTACT LENGTH

Contact type	Pin No.	Contact length
Power, ground pins	1, 17, 34, 35, 51, 68	5.0 mm (0.196 in.)
Card detection pins	36, 67	3.5 mm (0.137 in.)
Other signal pins	Others	4.25 mm (0.167 in.)

■ MATERIALS

Item	Specification
Insulating material	Plug body: PPS resin UL94V-0 : 6T nylon (for type III card connector) UL94V-0 Ejector: Polyester : PPS resin (for SMT and type III card connectors)
Conductor	Copper alloy
Plating	Contact: Gold over palladium over nickel (PAGOS) Terminal: Palladium

560H Series Connector Conforming to Ver. 4

CARDBUS, CARD LOCK TYPE / SUPPORTS TYPE 1 ~ III CARD

RIGHT-ANGLE PLUG, SMT LIGHT WEIGHT TYPE (WITH RIGHT-BUTTON EJECTOR, 2MM RAISED TYPE WITH FG CLIP)

■ DIMENSIONS (3.3V CARD SUPPORT)

Part number: FCN-568P068-G/1594-4E

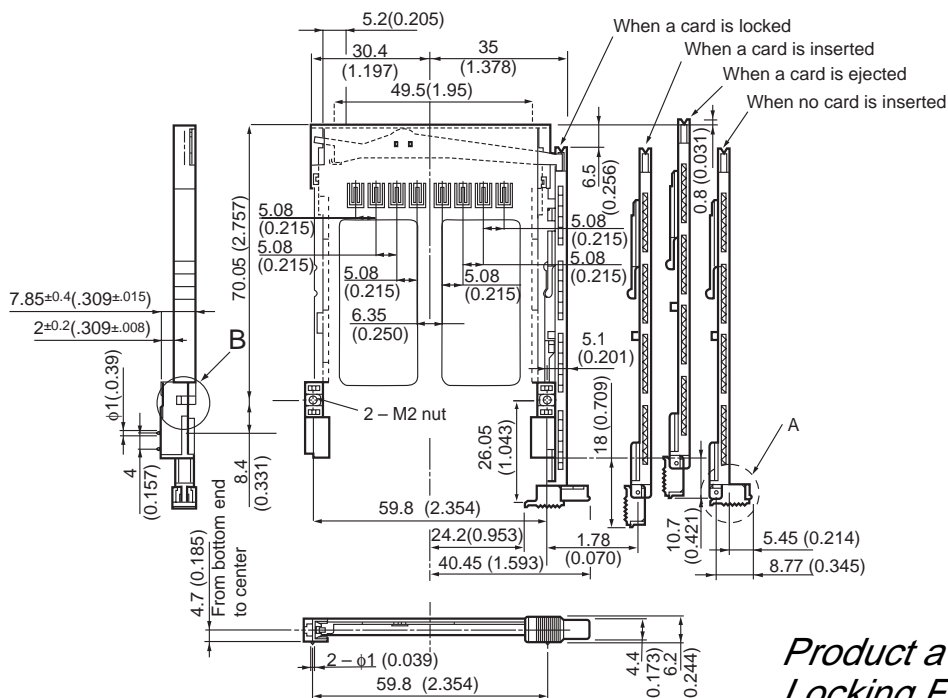
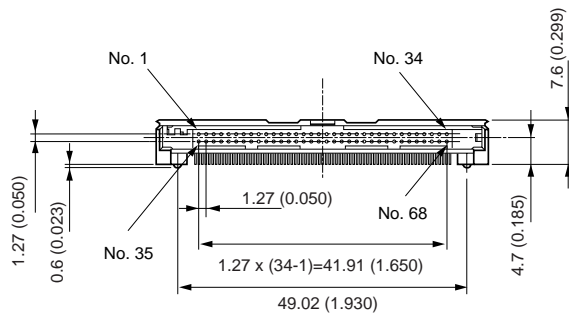
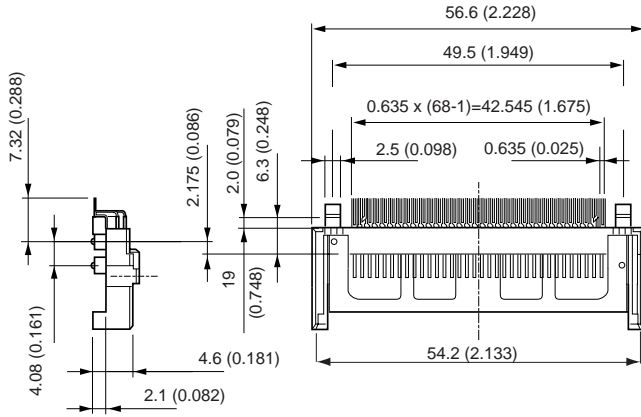
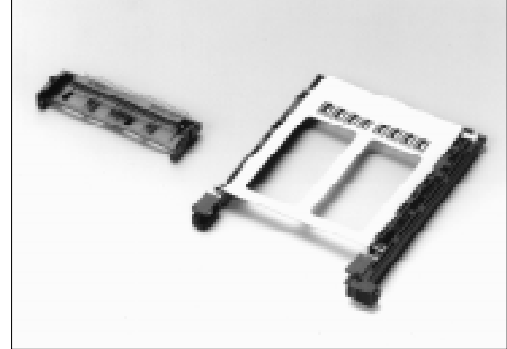

Product available with Non-Locking Feature. Please contact Factory for Details.

560H Series Connector Conforming to Ver. 4

CARDBUS, CARD LOCK TYPE / SUPPORTS TYPE 1 ~ III CARD

RIGHT-ANGLE PLUG, SMT LIGHT WEIGHT TYPE (WITH RIGHT-BUTTON EJECTOR, 2MM RAISED TYPE WITH FG CLIP)

■ PC BOARD MOUNTING PATTERN (MOUNTING SIDE)

Part number: FCN-568P068-G/1594-4E

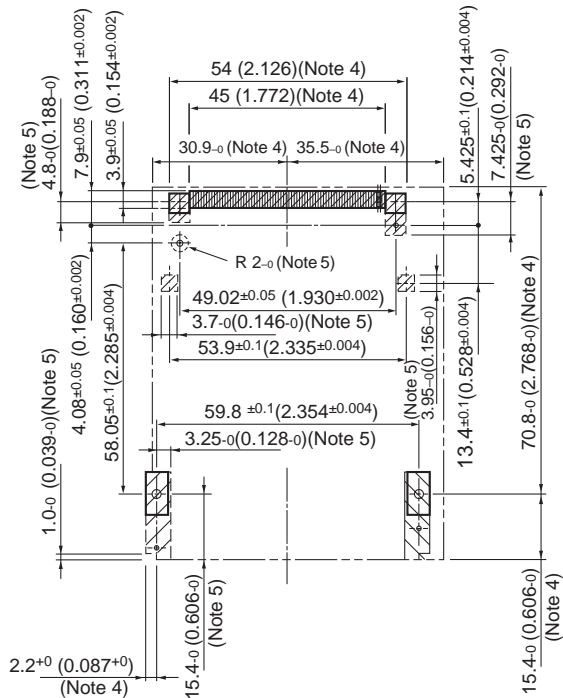
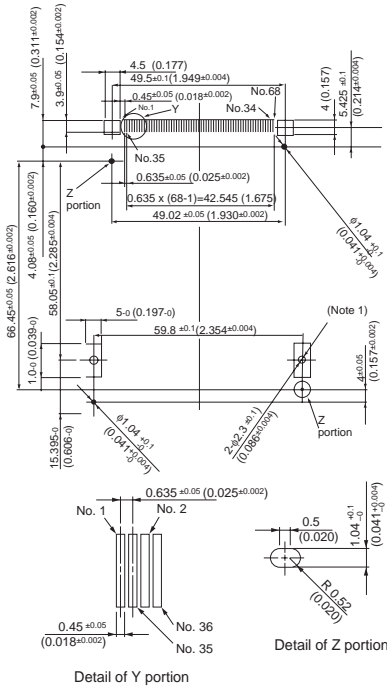

- Note 1: Ground Pattern
- Note 2: Pattern
- Note 3: This drawing is for the type to be inserted on the front of the PC board, and for the raised mounting type.
- Note 4: In the area enclosed by a chain double-dashed line, components with a 1.7mm height can be mounted
- Note 5: In the hatched area, component mounting is prohibited

Unit: mm (in.)

■ RECOMMENDED DIMENSION ■ CARD LOCK METHOD OF BODY (BUTTON AREA)

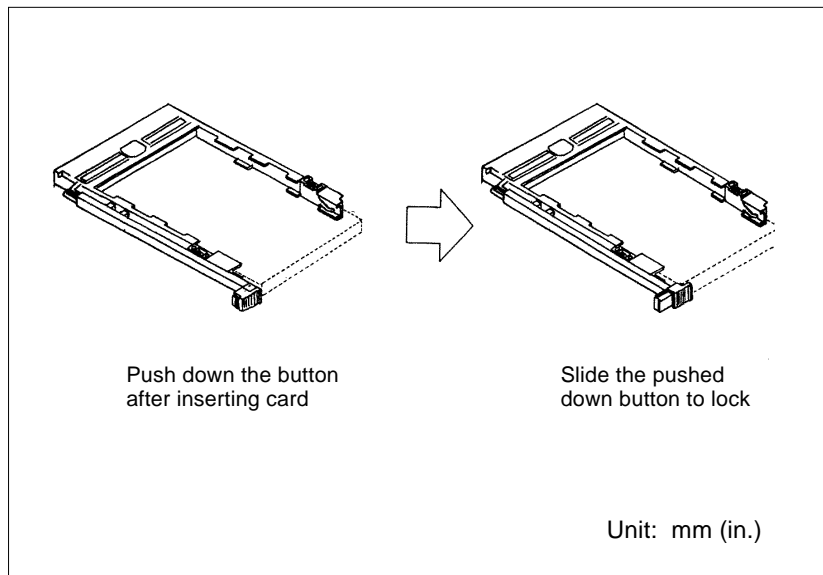
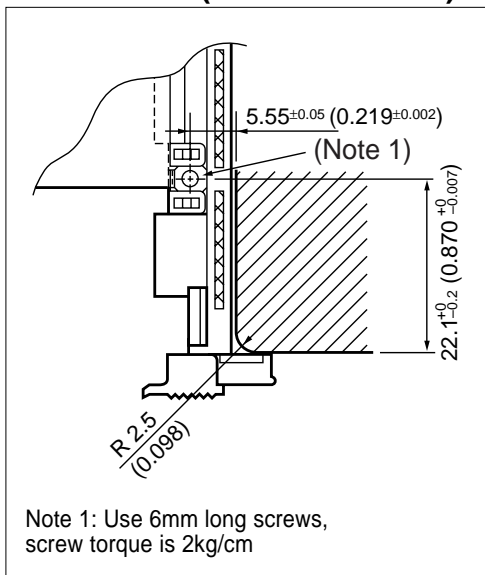

560H Series Connector Conforming to Ver. 4

RIGHT-ANGLE PLUG, SMT LIGHT WEIGHT TYPE

■ HOW TO MOUNT COMPACT AND LIGHT WEIGHT MEMORY CARD CONNECTOR

- The main body and ejector card are separated in this memory card connector

- MOUNTING**
- 1) Mount (solder) only the connector main body. Reinforced metal fittings conform to SMT specifications.
 - 2) Place the ejector (guide) on the main body and lock it to the main body.
 - 3) Secure the ejector (guide) from the back of the PC board using screws. By tightening these screws, the FG terminals contact the frame ground to ground the connector. (Screw torque is 2 kg/cm)

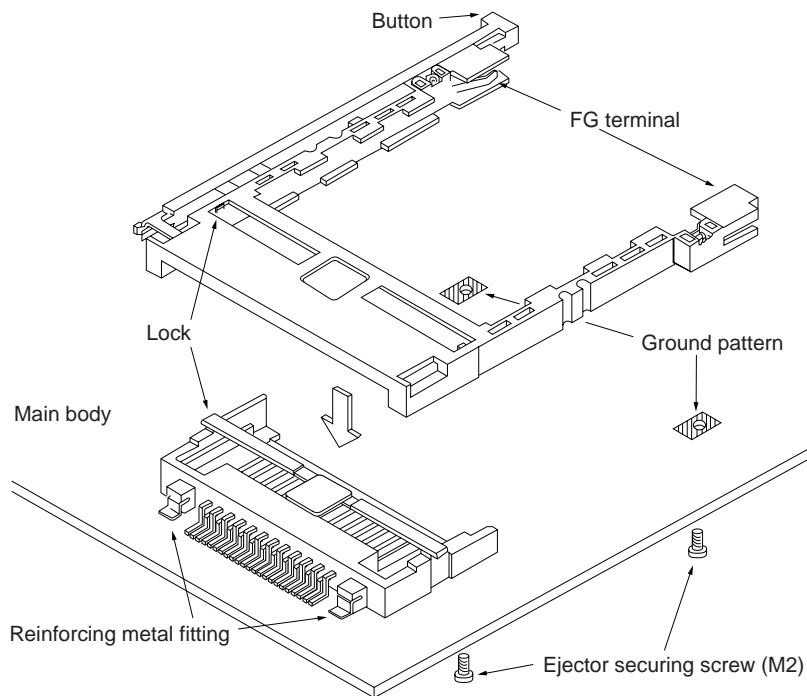

Fujitsu Components International Headquarter Offices

Japan

Fujitsu Component Limited
Gotanda-Chuo Building
3-5, Higashigotanda 2-chome, Shinagawa-ku
Tokyo 141, Japan
Tel: (81-3) 5449-7010
Fax: (81-3) 5449-2626
Email: promothq@ft.ed.fujitsu.com
Web: www.fcl.fujitsu.com

North and South America

Fujitsu Components America, Inc.
250 E. Caribbean Drive
Sunnyvale, CA 94089 U.S.A.
Tel: (1-408) 745-4900
Fax: (1-408) 745-4970
Email: marcom@fcai.fujitsu.com
Web: www.fcai.fujitsu.com

Europe

Fujitsu Components Europe B.V.
Diamantlaan 25
2132 WV Hoofddorp
Netherlands
Tel: (31-23) 5560910
Fax: (31-23) 5560950
Email: marketing@fceu.fujitsu.com
Web: www.fceu.fujitsu.com

Asia Pacific

Fujitsu Components Asia Ltd.
102E Pasir Panjang Road
#04-01 Citilink Warehouse Complex
Singapore 118529
Tel: (65) 375-8560
Fax: (65) 273-3021
Email: fcai@fcal.fujitsu.com
www.fcal.fujitsu.com

© 2002 Fujitsu Components America, Inc. All company and product names are trademarks or registered trademarks of their respective owners. Rev. 03/2002