

Amphenol

Amphenol-Tuchel Electronics GmbH

Smart Card Connectors Series C 700

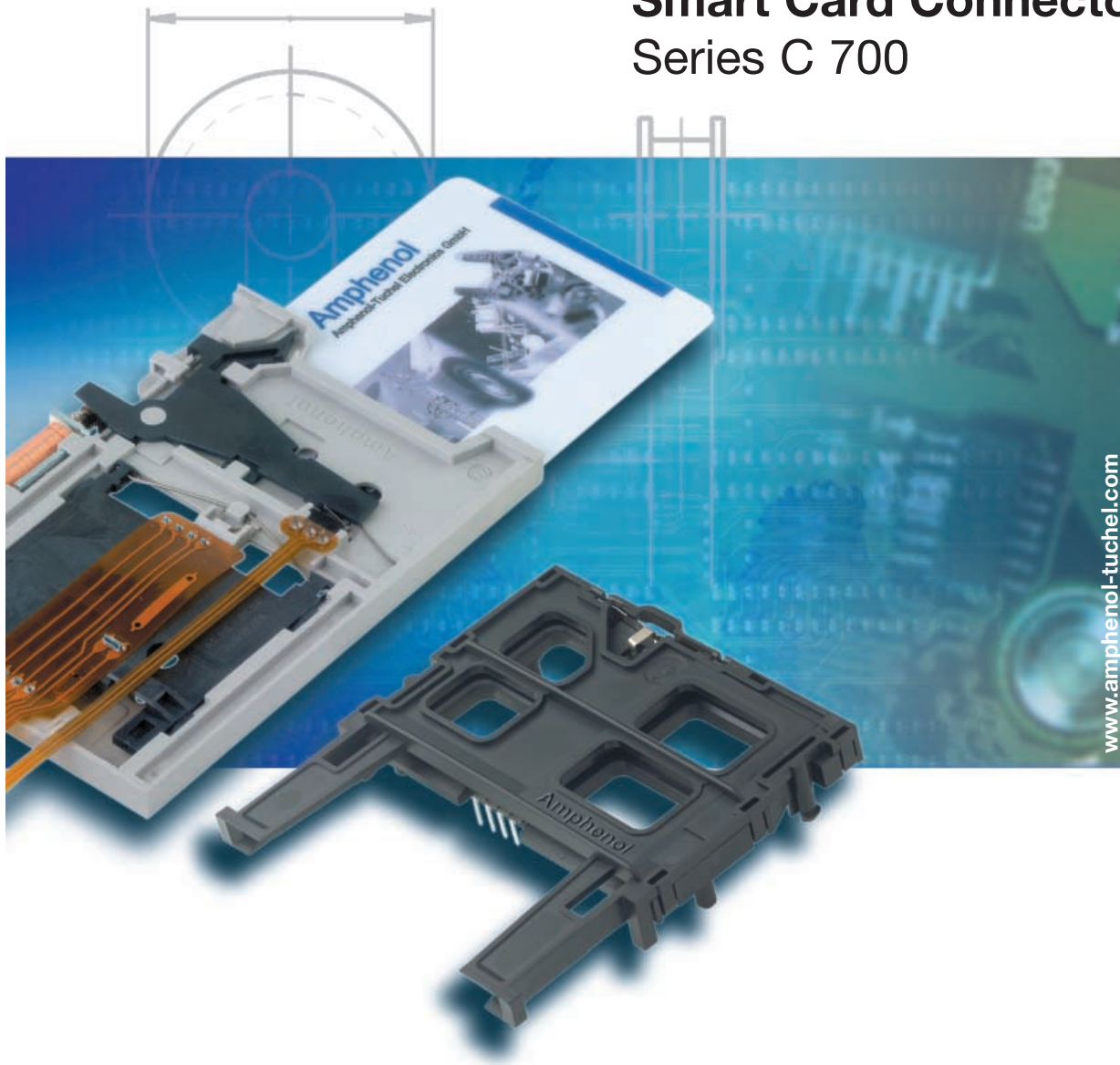



Security information

It is the user's responsibility to check whether the components illustrated in this catalogue comply with different regulations from those stated in special fields of application which we are unable to foresee.

These connectors are designed and produced in conformity with the low-voltage directive (72/73/EWG) respectively Gerätesicherheitsgesetz (German Law). We reserve the right to change the design due to improvement in quality, development or production requirements.

This catalogue must not be used in any form or manner without our prior approval in writing (Copyright Law, Fair Trading Law, Civil Code).

IP degree of protection for all Smart Card Connectors is IP 00, if not mentioned otherwise in technical data.

As far as Smart Card Connectors are mentioned without protection against electric shock, only Safety Extra Low Voltage (SELV) of AC 25 V_{eff} or DC 50 V is permissible. When mounted with protection against electric shock see table rated voltage acc. to IEC 60664-1.

The products specified in this catalogue have been developed for soldering proceedings with Sn Pb alloys. Other soldering proceedings are possible upon request.

Basically Smart Card Connectors are designed for indoor and outdoor applications with low dirt/dust contamination and environmental influences.

Connectors and/or plug and socket devices may only be used according to the specified technical ratings.

Please note that technical ratings represent often only initial values which have been investigated under determined conditions (tests) and may change under longer or stress conditions.

The referred IEC-Standards correspond to the DIN EN-Standards.

Contents

 Worldwide Performance Page 4	The Company Quality Leading Technology	 Series C703A Page 41	Hybrid Reader
 General Information Page 6	Chip Cards Smart Card Connectors Card Handling Systems Contact Methods	 Series C705A Page 44	Smart Card Connectors with Disk Drive Slot
 Series C702A Page 10	Smart Card Connectors Standard Style Accessories	 Series C707A Page 46	Smart Card Connectors SIMLOCK®
 Series C702B Page 17	Smart Card Connectors PUSHMATIC® II Accessories	 Series C707B Page 50	Smart Card Connectors SIMBLOCK®
 Series C702C Page 22	Smart Card Connectors Low Profile PUSHMATIC®	 Series C709A Page 55	MultiMediaCard Connector
 Series C702D Page 25	Smart Card Connectors Superflat Style Accessories	Keyword Index Page 58	
 Series C702E Page 31	Smart Card Connectors with PCB Mount Wiping Contacts	Part No. Index Page 59	
 Series C702F Page 39	Smart Card Connectors with Landing Card PCB Mount		

Worldwide Performance

The Company

Amphenol-Tuchel Electronics GmbH is a global company and leading manufacturer of electrical connector solutions.

The superior quality of our product line is a result of specialized engineering and techniques in conjunction with leading edge production methods.

Our worldwide production and sales channels provide local competency in a global marketplace. Amphenol has set standards in electrical connector technology with our many inventions and patents.

These solutions are reflected in product applications used by the industrial machine tool, automotive, telecom as well as datacom markets.



Quality

Quality stands not only for product quality but also for the quality of the connection solution. At Amphenol-Tuchel Electronics, quality is one of the first considerations during the initial development steps. The emphasis is not on the product, but on the existing requirements. Engineers with many years of experience work in interdisciplinary project teams to develop and supply absolutely reliable connection solutions.

Amphenol-Tuchel is certified in accordance with ISO 9001, QS 9000 and VDA 6.1, which means that not only the organizational prerequisites for compliance with the required product quality exist, but that they are actually applied throughout the process chain.

It goes without saying that all Smart Card connectors of the Amphenol product range meet the specified product characteristics. The various electrical, climatic and mechanical parameters are examined and tested in comprehensive inspections.

Technological Leadership

Amphenol-Tuchel Electronics derives its claims to technical advances and technological leadership from various technical and technological advantages.

These include high-performance precision pressing technology, modern injection-molding technology and a manufacturing and inspection technology which ensures that all processes operate reliably.

Production flexibility is guaranteed by the use of either fully automatic production equipment, semi-automatic production lines or manual manufacture, depending on the requirements.

Samples can be produced in a very short time and it is also possible to execute the entire production cycle from the prototype to the finished product quickly. Customer-specific prototypes and small batches can also be produced quickly.

The experience and competence gained through many decades of work are displayed today in the wide range of proven products in the sectors of plug and socket connectors and Smart Card Connectors.

An innovative internal product development department, a flexible, selective network of suppliers, coupled with an internal laboratory for support of research and product development, together with 3D-CAD and simulation work stations adds up to a company which can be measured by its own standards.

C700 Smart Card Connectors: General Information

Chip Cards

Chip Cards, Smart Cards, IC Cards or whatever application specific term is used ... have one thing in common:

- the outside dimensions, standardized acc. to ISO 7810, the size of a common credit card
- and the position of the contact pads, (which connect the embedded IC chip) are fixed according to ISO 7816.

The most used chip contacts are:

Type ID-1, Chip middle position (ISO)

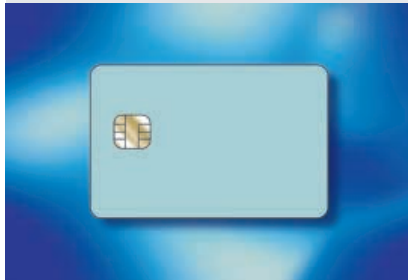

Type ID-1, Chip outer position (AFNOR)

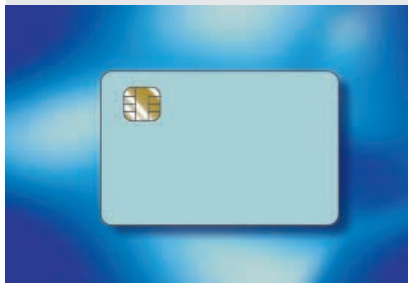

SIM/SAM-Card, ID-000, GSM 11.11

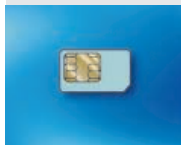

MultiMediaCard, acc. to MMCA - Spezifikation



Secure Digital Memory Card, acc. to SDA - Spezifikation



Amphenol Smart Card Connectors

Smart Card Connectors are integral components of a smart card reader or terminal, and provide electrical contact to the smart card's pads. The connector is not a stand alone peripheral device.

An additional interface circuit is necessary to be able to read and write to the smart card whether a smart card is a memory only or a microprocessor card. Amphenol Smart Card Connectors are designed to make secure contact to all cards designed according to ISO 7816 and thus ensure a reliable data transmission.



The communication with the chip card can begin when the card is fully inserted and the data contacts are all connected. At this point an integral card presence switch is activated and signals to the connected circuitry that the card is ready to be read and written to.

Smart Card Connectors for payment systems according to EMV (Europay Mastercard Visa / Integrated Circuit Card Specification for Payment Systems) have a specific card end position switch which detects the insertion and removal of a Smart Card.



Card Handling Systems

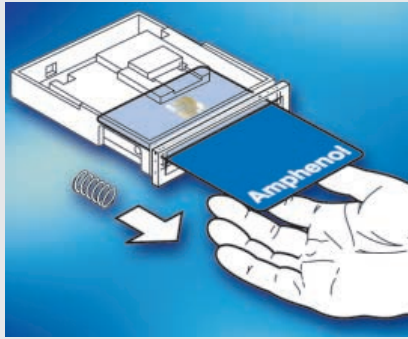
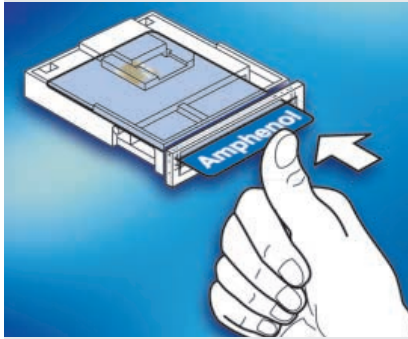

Push-Only

The card is inserted manually and held in the active position by hand. The card is ejected immediately after the user releases it. The Push-Only is ideally suited for applications with short transaction cycles, ie. door access control.

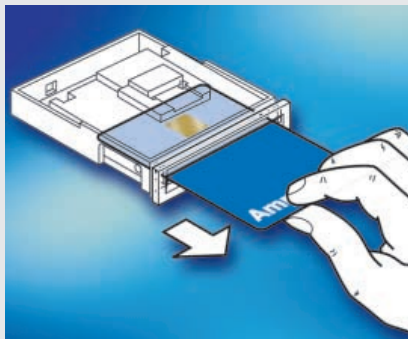
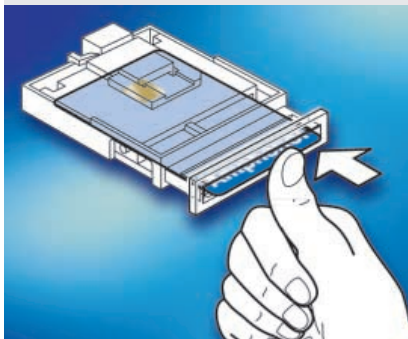

Push-Pull

The card is inserted manually and held in the active position by a card brake. After completion of the transaction, the card is simply pulled out of the Smart Card Connector.

This is the most common manual card handling system.

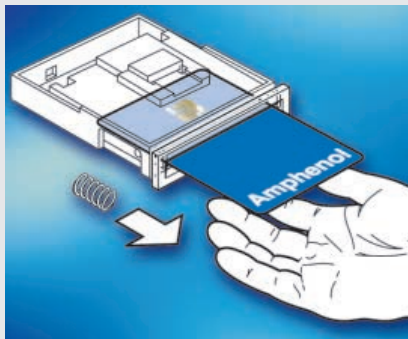
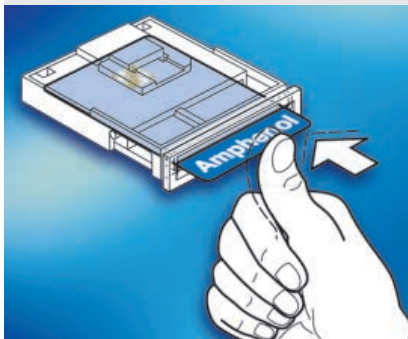

Push-Push

The card is inserted manually and held in the active position by the Smart Card Connector. When pushed again the card is returned to the user (principle of a ballpoint pen).

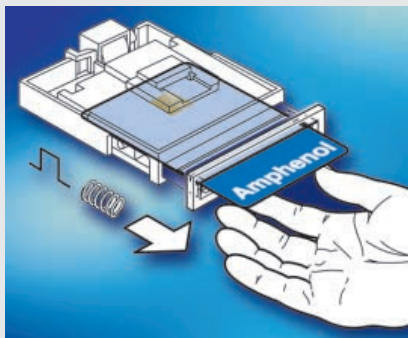
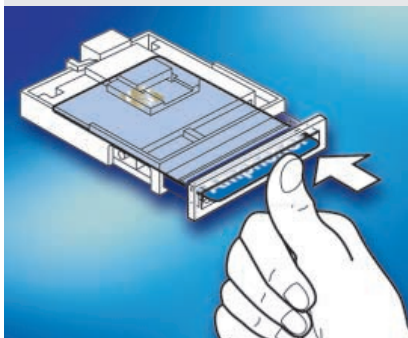

PUSHMATIC®

This semi-automatic system combines a manual card insertion with an automatic card ejection. The card is manually pushed into the Smart Card Connector until it is flush (or nearly flush) with the bezel. Upon completion of the transaction, software triggers a solenoid and the card is ejected back to the user.

Contact Methods

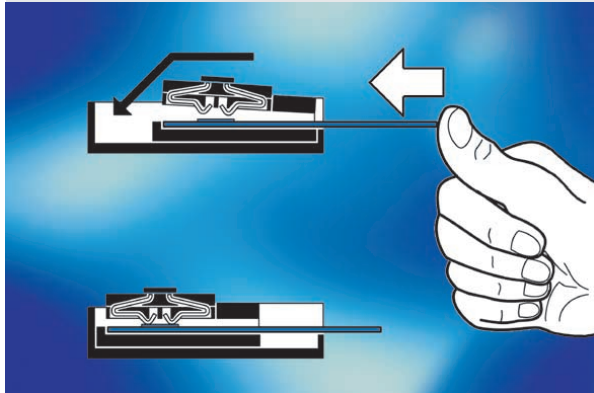

Landing Contacts

With this contact method a moveable contact set will connect with the pads of the chip card upon insertion of the card.

The card plastic surface is not scratched and high mating cycles can be achieved.

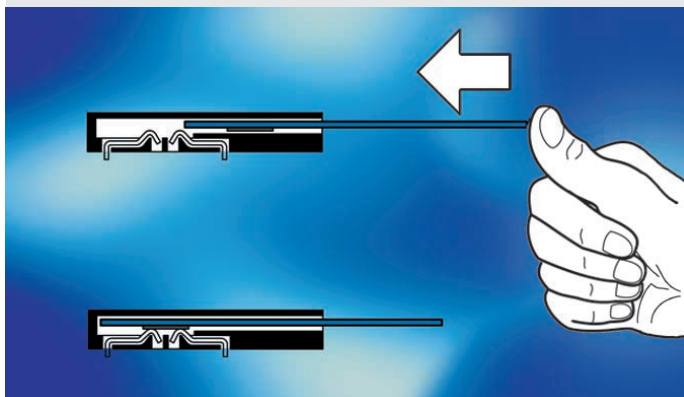

Wiping Contacts

The contact set is fixed. When the card is inserted, it wipes over the data contacts until they arrive at the card pads. Depending upon the card surface, wiping traces which do not influence the card function can occur after some insertion cycles.

The advantage of wiping contacts is that they clean the contact point with every mating cycle.

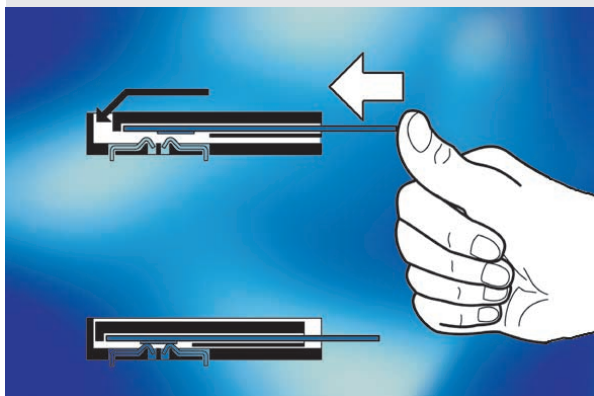

Landing Card

This method of contacting is based on a fixed contact set. The chip card is lowered during its insertion.

The contact areas of the chip card land smoothly on the reading contacts which results in the possibility of a high number of mating cycles.

In addition this system makes sure that with each insertion the contact surfaces are cleaned.

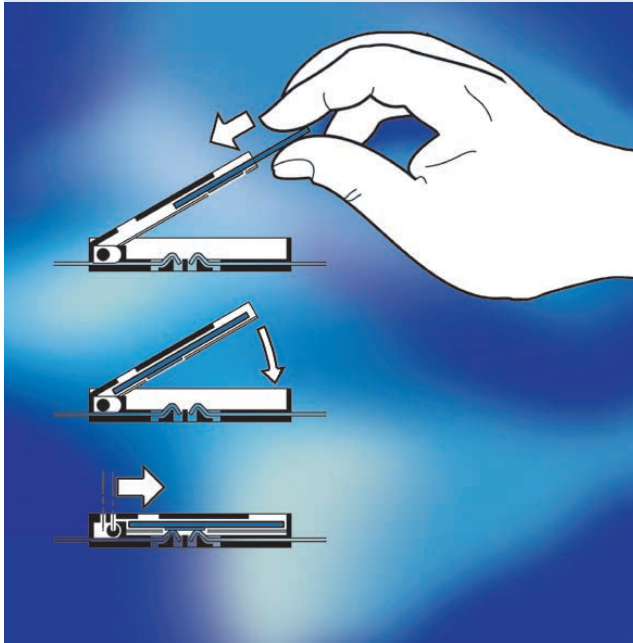

SIMLOCK®

In cases where chip cards with the dimensions of a full size ISO 7816 are too large, the SIMLOCK® comes into use. With its latching cover for the insertion of the smaller SIM card it offers a safe contact interface even in mobile usage.

Due to the locking system the user does not have to consider tolerances or card guiding.

The design and packaging of the Amphenol SIMLOCK® allows manual and automatic pick and placement prior to surface mount soldering.

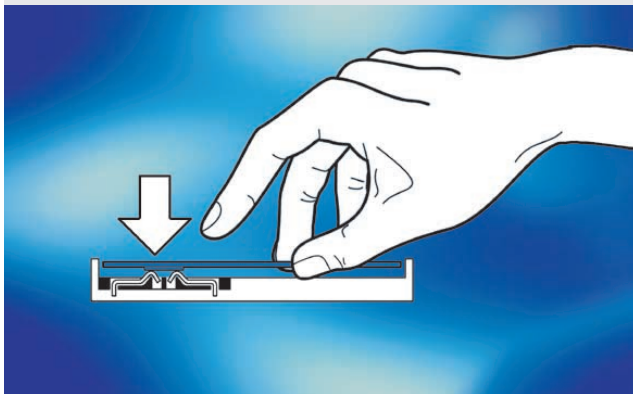

SIMBLOCK®

These Smart Card Connectors, due to their minimal space requirement and low height are the ideal components for many space restricted applications, from handsets to the electronic purse. The connector is suitable for standard chip cards per ISO 7816 as well as for plug-in SIM cards.

The SMT terminals and packaging for automatic handling allow the use of pick and place robots and modern surface solder technologies.

Positioning and support of the chip card has to be ensured by the user.

Smart Card Connectors

Standard Style

Series C702A





 Push-Only Page 11

 Push-Pull Page 11

 Push-Push Page 12

 PUSHMATIC® Page 12

 PUSHMATIC® with Locking Detector Page 13

 PUSHMATIC® with Shutter Page 13

 Accessories Mounting Plate Page 15

 Accessories Bezel Page 16

The Standard Style is our original first generation product family featuring landing contacts for rugged applications such as: Point of Sale systems, vending equipment and access control.

Design features

- high numbers of card insertion cycles, due to the principle of landing and self-cleaning contacts
- designed for harsh applications and environments
- modular system with several operating methods from manual handling to automatic card ejection
- various termination options: flat cable in standard and custom lengths with sockets according to IEC 60 603-13; and flexprints. For appropriate flexprint connectors see page 29
- Accessories: Shutter and bezel, mounting plate



Assembly instructions:
Please make sure that interface cables are unrestricted and free to move after assembly.

C702A Smart Card Connectors Standard Style Push-Only



Description	Contact position	Part No.
Push-Only	ISO	C702 10M008 018 2

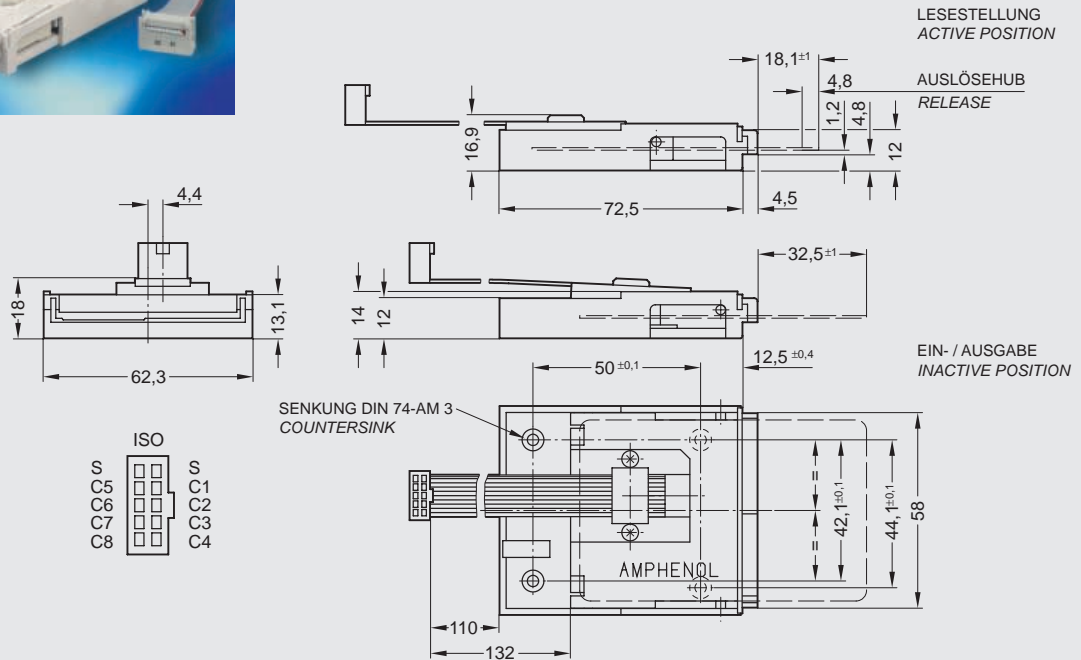

C702A Smart Card Connectors Standard Style Push-Pull



Description	Contact position	Additional information	Part No.
Push-Pull	ISO Standard		C702 10M008 514 2
	AFNOR		C702 10M008 522 2
	ISO + AFNOR	Contacts in series	C702 10M008 521 2
	ISO + AFNOR	Contacts in parallel	C702 10M008 523 2

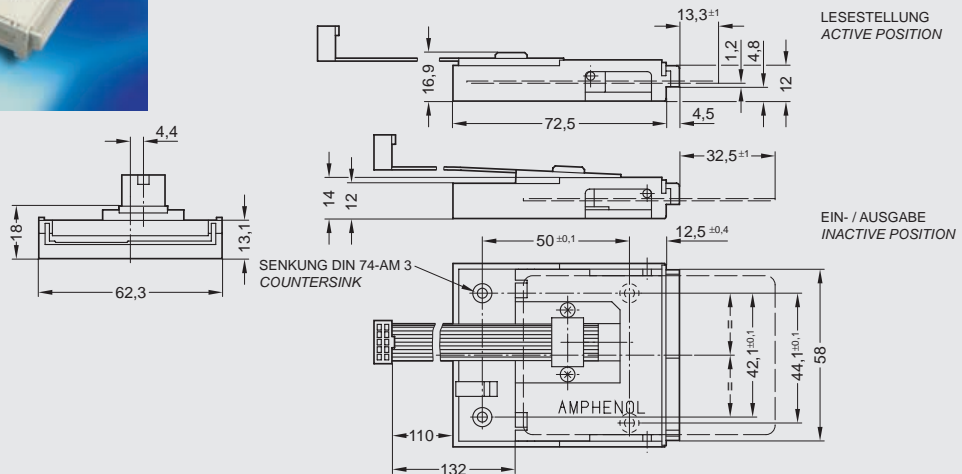

Belegung Steckverbinder ISO	Connector termination ISO + AFNOR Kontakte in Reihe / Contacts in series	AFNOR	ISO + AFNOR Kontakte parallel / Contacts in parallel																																															
<table border="0"> <tr><td>S</td><td>C5</td><td>C6</td><td>C7</td><td>C8</td><td>S</td><td>C1</td><td>C2</td><td>C3</td><td>C4</td></tr> </table>	S	C5	C6	C7	C8	S	C1	C2	C3	C4	<table border="0"> <tr><td>S</td><td>C4</td><td>C3</td><td>C2</td><td>C1</td><td>S</td><td>C8</td><td>C7</td><td>C6</td><td>C5</td></tr> </table>	S	C4	C3	C2	C1	S	C8	C7	C6	C5	<table border="0"> <tr><td>S</td><td>C4</td><td>C3</td><td>C2</td><td>C1</td><td>S</td><td>C8</td><td>C7</td><td>C6</td><td>C5</td></tr> </table>	S	C4	C3	C2	C1	S	C8	C7	C6	C5	<table border="0"> <tr><td>nc</td><td>S</td><td>C4</td><td>C3</td><td>C2</td><td>C1</td><td>nc</td><td>S</td><td>C8</td><td>C7</td><td>C6</td><td>C5</td><td>C4</td><td>C3</td><td>C2</td><td>C1</td><td>nc</td></tr> </table> <p>nc = frei not connected</p>	nc	S	C4	C3	C2	C1	nc	S	C8	C7	C6	C5	C4	C3	C2	C1	nc
S	C5	C6	C7	C8	S	C1	C2	C3	C4																																									
S	C4	C3	C2	C1	S	C8	C7	C6	C5																																									
S	C4	C3	C2	C1	S	C8	C7	C6	C5																																									
nc	S	C4	C3	C2	C1	nc	S	C8	C7	C6	C5	C4	C3	C2	C1	nc																																		

C702A Smart Card Connectors Standard Style Push-Push

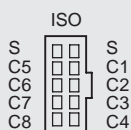
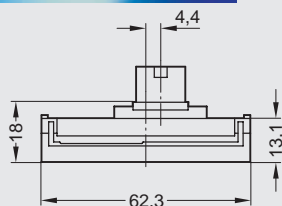

Description	Contact position	Part No.
Push-Push	ISO	C702 10M008 015 2

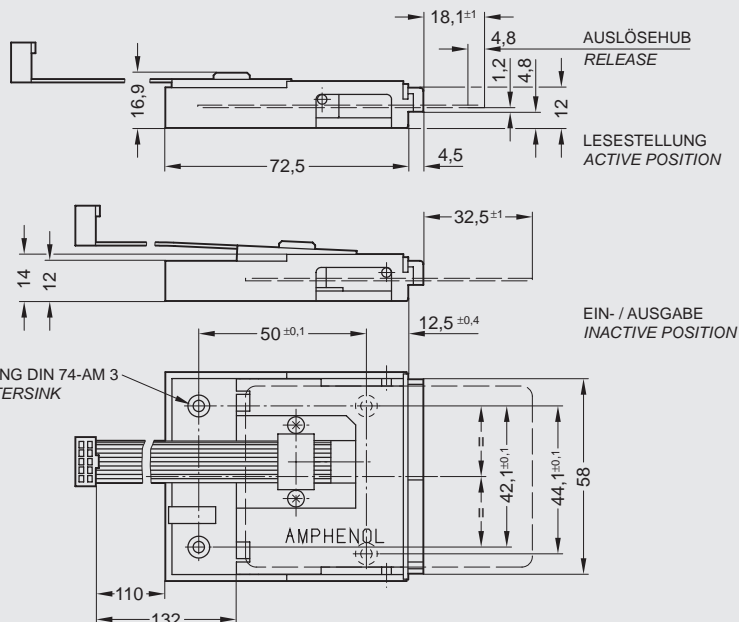

C702A Smart Card Connectors Standard Style PUSHMATIC®



Description	Solenoid voltage	Contact position	Additional information	Part No.
PUSHMATIC®	5 V	ISO Standard		C702 10M008 701 2
	12 V	ISO Standard		C702 10M008 700 2
	24 V	ISO Standard		C702 10M008 702 2
	5 V	ISO + AFNOR	Contacts in series	C702 10M008 703 2
	12 V	ISO + AFNOR	Contacts in series	C702 10M008 704 2
	24 V	ISO + AFNOR	Contacts in series	C702 10M008 705 2
	5 V	ISO + AFNOR	Contacts in parallel	C702 10M008 706 2
	12 V	ISO + AFNOR	Contacts in parallel	C702 10M008 707 2
	24 V	ISO + AFNOR	Contacts in parallel	C702 10M008 708 2

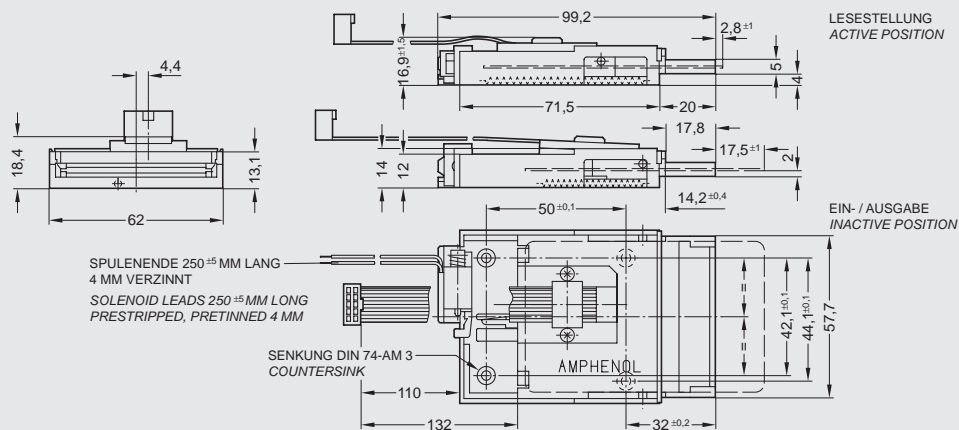

Belegung Steckverbinder / Connector termination	ISO + AFNOR Kontakte in Reihe / Contacts in series	AFNOR	ISO + AFNOR Kontakte parallel / Contacts in parallel
ISO			

C702A Smart Card Connectors Standard Style PUSHMATIC® with Locking Detector



Description	Solenoid voltage	Contact position	Part No.
PUSHMATIC®	5 V	ISO	C702 10M008 732 2
with Locking Detector	12 V	ISO	C702 10M008 716 2
	24 V	ISO	C702 10M008 727 2

In addition to the features of the PUSHMATIC®, this version offers an additional switch, which indicates the complete insertion of the card and the locking of the contact set.

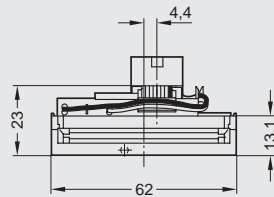

SCHALTER MELDET:
1. SYSTEMVERRIEGELUNG
2. KONTAKT IN LESESTELLUNG

TWO SWITCHES IN SERIES DETECT:
1. CONTACT SYSTEM LOCKED
2. DATA CONTACTS IN ACTIVE POSITION

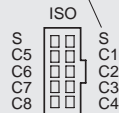

SPULENENDE 250^{±5} MM LANG
4 MM VERZINNT
SOLENOID LEADS 250^{±5} MM LONG
PRESTRIPPED, PRETINNED 4 MM

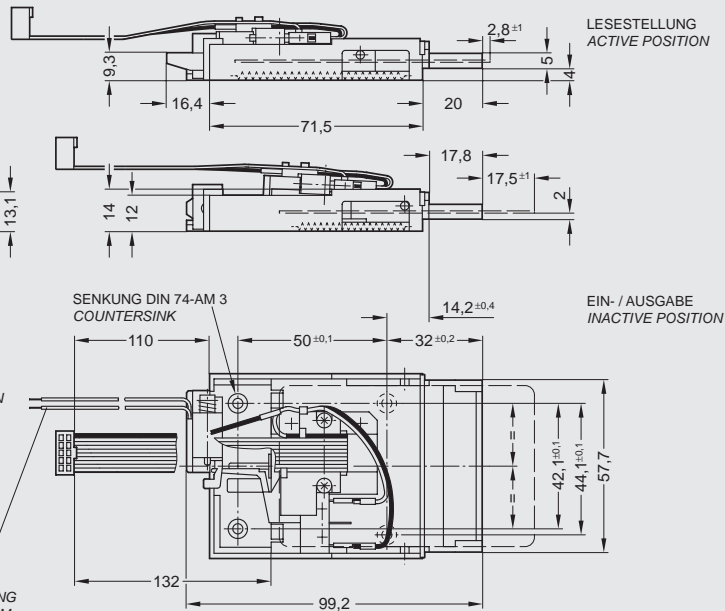

C702A Smart Card Connectors Standard Style PUSHMATIC® with Shutter



Description	Solenoid voltage	Contact position	Part No.
PUSHMATIC®	5 V	ISO	C702 20M008 701 2
with Shutter	12 V	ISO	C702 20M008 700 2
	24 V	ISO	C702 20M008 702 2

The shutter protects the card slot if no card is inserted and will only open upon insertion of a standard size card. The insertion of coins, paper, clips, etc... is not possible. An additional bezel is not required.

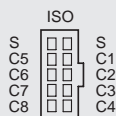
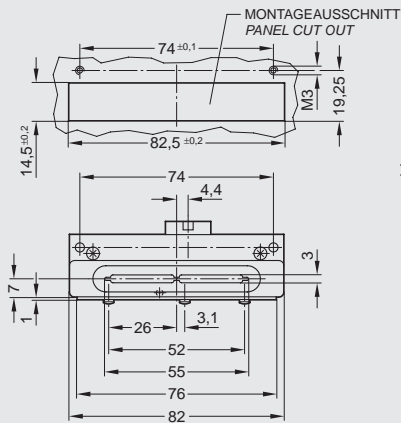

SPULENENDEN 250^{±5} MM LANG
4 MM VERZINNT
SOLENOID LEADS 250^{±5} MM LONG
PRESTRIPPED, PRETINNED 4 MM

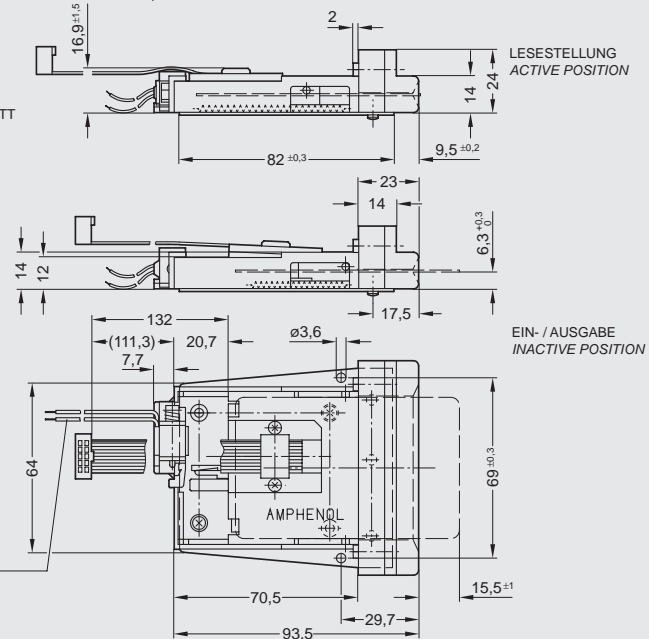

C702A Technical Data

Electrical Characteristics	Standard	Value
Contact resistance incl. 150 mm ribbon cable and male connector	IEC 60512-2, Test 2a	Data contacts $\leq 100 \text{ m}\Omega$ Switch contacts $\leq 200 \text{ m}\Omega$
Insulation resistance	IEC 60512-3, Test 3a	$\geq 10^9 \Omega$
High voltage resistance	IEC 60512-2, Test 4a	500 V _{AC} ; 1 min

Unlocking solenoid (PUSHMATIC® only)

Rated voltage		5 V \pm 10%	12 V \pm 10%	24 V \pm 10%
Current consumption		2.5 A \pm 10%	1.1 A \pm 10%	0.55 A \pm 10%
Current pulse length		10 ... 25 ms		
Pulse break		$\geq 0.5 \text{ s}$		

Climatical Characteristics

Climatic category	IEC 60068-1	25 / 85 / 21
Operating temperature		- 25 °C ... + 85 °C
Storage temperature		- 25 °C ... + 85 °C

Mechanical Characteristics

	Push-Push	Push-Only	Push-Pull	PUSHMATIC®	PUSHMATIC® with Locking Detector	PUSHMATIC® with Shutter
Card insertion force IEC 60512-7, Test 13b	3 ... 5 N	3 ... 5 N	$\leq 12 \text{ N}$	$\leq 3.5 \text{ N}$	$\leq 5 \text{ N}$	$\leq 8 \text{ N}$
Card extraction force IEC 60512-7, Test 13b	–	–	$\geq 2.5 \text{ N}$	–	–	–
Mechanical lifetime IEC 60512-5, Test 9a (without corrosion stress)	500,000 mating cycles	500,000 mating cycles	500,000 mating cycles	300,000 mating cycles	300,000 mating cycles	200,000 mating cycles
Vibration	IEC 60512-4, Test 6d			f = 10 ... 60 Hz 0.5 mm DA f = 60 ... 500 Hz a = 2.5 g 2 h / axis		
Shock, without disconnection	IEC 60512-4, Test 6c			$\leq 10 \text{ g}$; 11 ms; halfsine 2 shocks / direction in 3 axis		
Shock, without destruction	IEC 60512-4, Test 6c			$\leq 200 \text{ g}$; 6 ms; halfsine 2 shocks / direction in 3 axis		
Contact force				20 ... 50 cN		

Switch

Card presence switch		normally open
Locking detector		is activated when contact system is locked switch rating 100 mA / 12 V
Switch sequence	The card presence switch is activated after data contacts have mated with the card pads and before the card reaches its final position. This sequence will take place for the minimum sized card pads (and larger) acc. to ISO 7816	
Chattering time		$\leq 5 \text{ ms}$

Termination

Suitable connector

Connector for flat cable, female connector IEC 60603-13, no. of contacts: 10 or 20	Male connector IEC 60603-13 Amphenol Series 816 and 821
Solenoid termination: wire 0,09 mm ² / AWG 28	

PUSHMATIC® with Shutter

IP-degree of protection Smart Card Connector assembled	IEC 60529	No card inserted IP 30 card inserted IP 20
---	-----------	---

Climatical Characteristics

Operating temperature		+ 10 °C ... + 55 °C, without condensation
Storage temperature		- 25 °C ... + 85 °C, without condensation

C702A Smart Card Connectors Standard Style Accessories

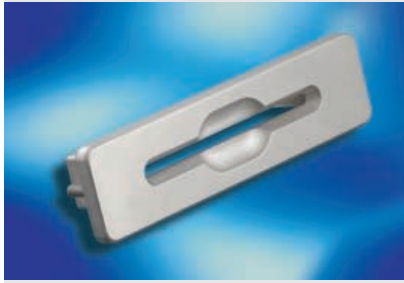

C702 N13 030 E2



C702 N13 031 E2



C702 N15 100 G2

Description	Version	Part No.
Metal bezel silver coloured	PUSHMATIC®	C702 N13 030 E2
Metal bezel dull black	PUSHMATIC®	C702 N13 031 E2
Mounting plate (metal) for bezel	PUSHMATIC®	C702 N15 100 G2



Assembly instructions:

Mounting plate (i.e. C702 N15 100 G2) is necessary for assembly of bezel.

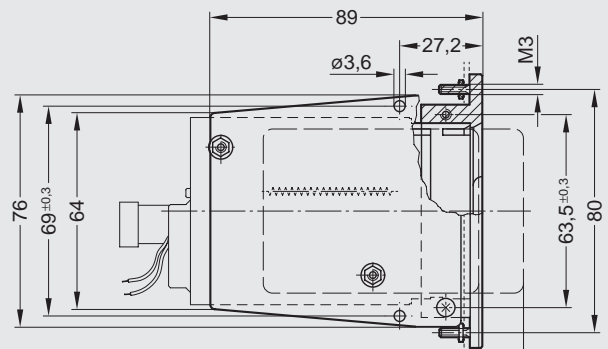
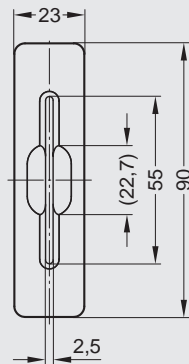
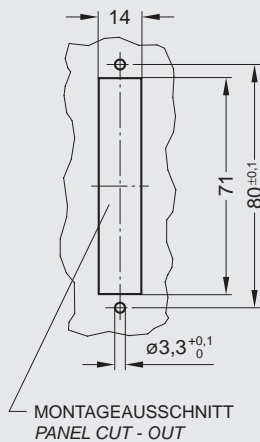

LESESTELLUNG
ACTIVE CARD - POSITION → 22,8 ±1
EIN- / AUSGABE
INACTIVE CARD - POSITION → 37,5 ±1

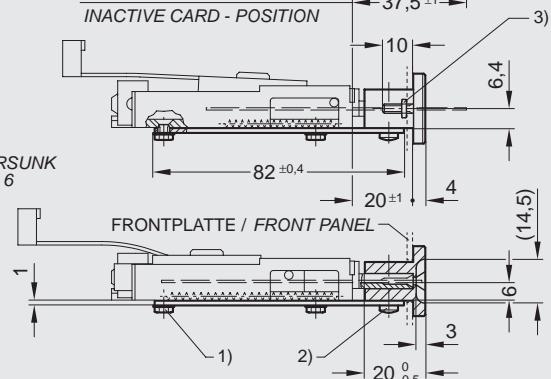

- 1) 2 x SENKSCRAUBE MIT KREUZSCHLITZ DIN 965 - M3 x 6
- 2 x SECHSKANTMUTTER DIN 439 - M3
- 2 x SCHEIBE DIN 125 - 3,2
- 2) 2 x GEWINDEFURCHENDE SCHRAUBE DIN 7500 - AM 3 x 10 - ST
- 3) 2 x SECHSKANTMUTTER DIN 934/439 - M3

LIEFERUNG OHNE SCHRAUBEN UND MUTTERN

- 1) 2 x CROSS RECESSED COUNTERSUNK HEAD SCREW DIN 965 - M3 x 6
- 2 x HEXAGON NUT DIN 439 - M3
- 2 x WASHER DIN 125 - 3,2
- 2) 2 x THREAD ROLLING SCREW DIN 7500 - AM 3 x 10 - ST
- 3) 2 x HEXAGON NUT DIN 934/439 - M3

SHIPMENT WITHOUT SCREWS AND NUTS

C702A Smart Card Connectors Standard Style Accessories



Description	Version	Part No.
Metal bezel with 'coin spacer' silver coloured	PUSHMATIC®	C702 N14 030 E2

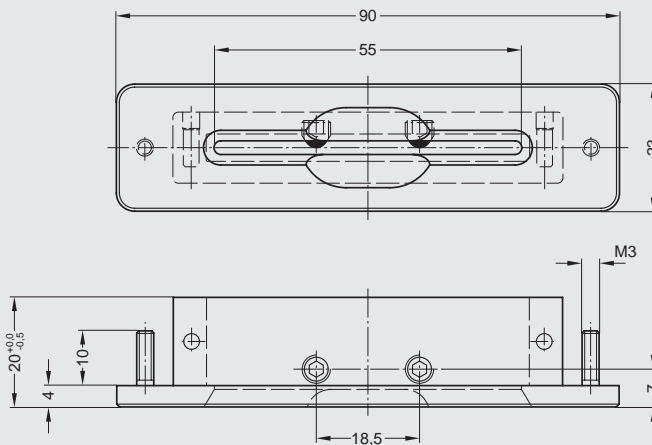

Assembly instructions see page 15

C702A Smart Card Connectors Standard Style Accessories



Description	Version	Dimension without distance plate		Dimension with distance plate		Part No.
		a	b	0.5 mm	1 mm	
Plastic bezel black	Push-Pull	7.0 mm	2.3 mm	1.8 mm	1.3 mm	C702 N11 141 E2
	Push-Only					
	Push-Push	11.8 mm	2.3 mm	1.8 mm	1.3 mm	
Distance plate	0.5 mm					N06 702 000 2
Distance plate	1 mm					N06 702 000 1

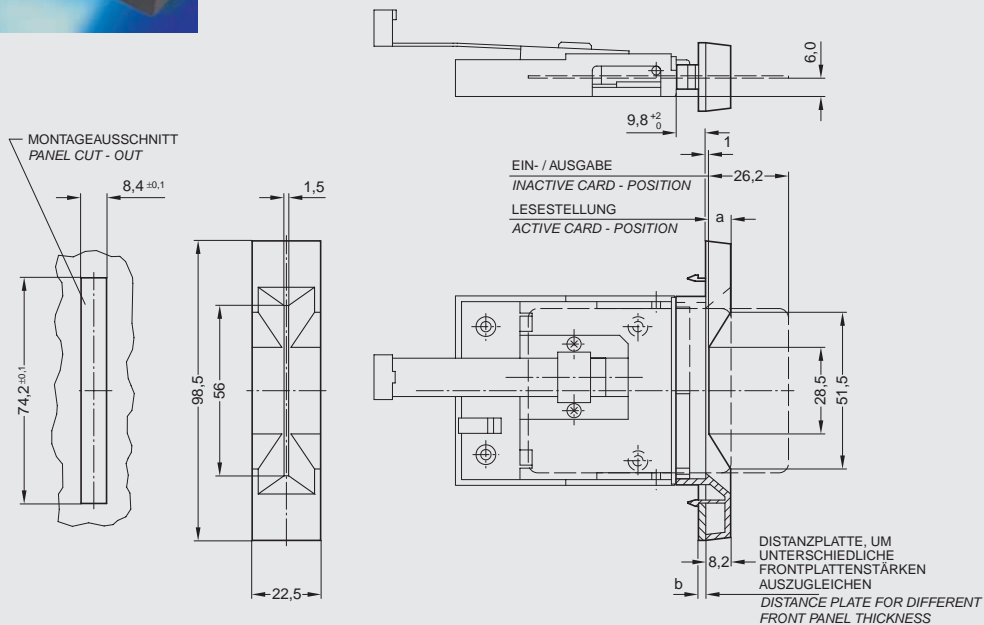

Smart Card Connectors

PUSHMATIC® II

Series C702B

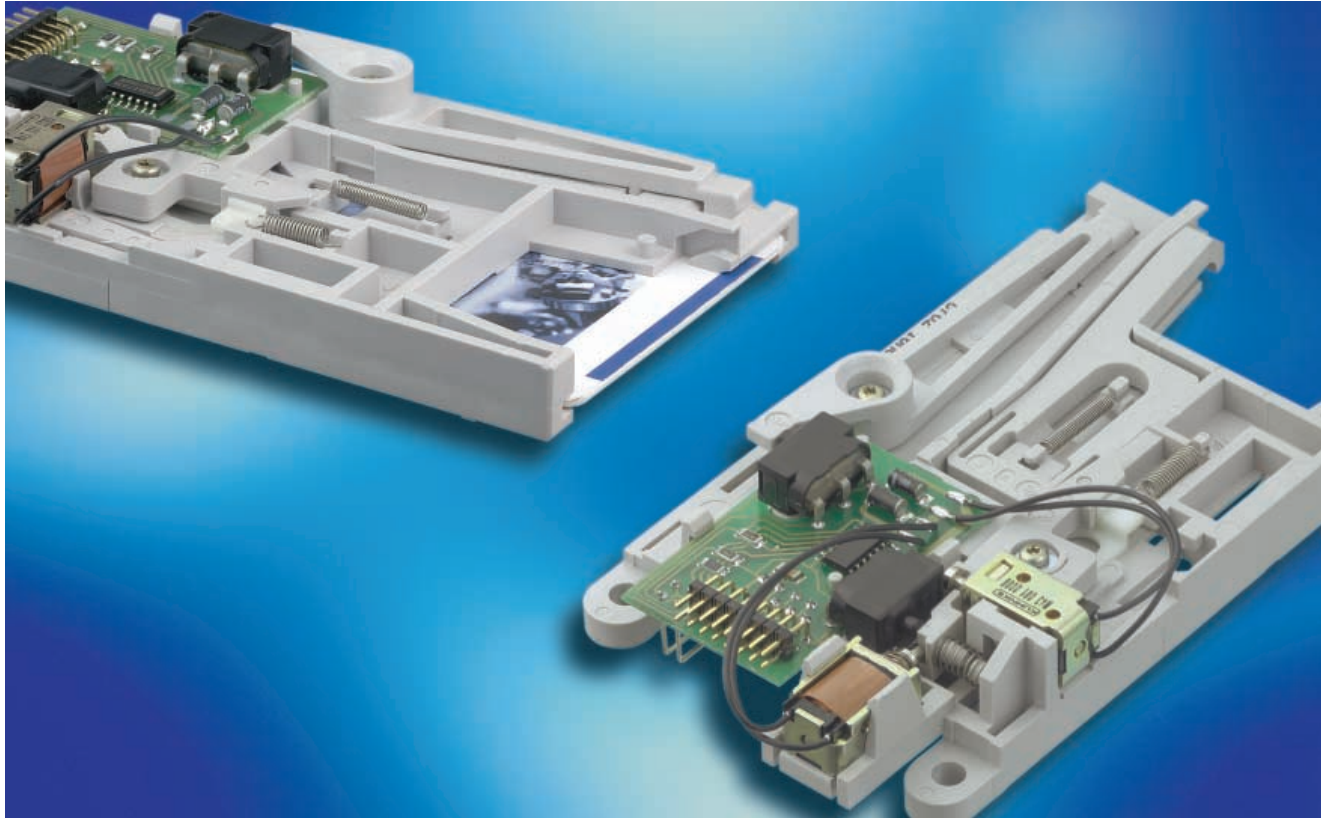

without card locking Page 18



with card locking Page 18



Accessories Page 20
Bezel/
Mounting Plate



Accessories Page 21
Adaptor

PUSHMATIC® II

While smaller in size than our standard PUSHMATIC®, the PUSHMATIC® II provides additional performance and “anti-vandal” features. With this added functionality the PUSHMATIC® II meets requirements of new and future applications for unattended terminals used in payment and security system applications.

Design features

- miniaturized style, suitable for mobile interface devices
- card accessible during power failure
- card locked in active position (option; see ordering table)
- card presence switch, also can be used for system wake up
- card end position switch acc. to EMV acts as card locking sensor
- additional sensor for card active position detects abnormal termination of the transaction
- self retracting and self cleaning data contacts provide protection against vandalism
- housing bottom features a large debris slot allowing the egress of coins, paper, as well as cut in half cards
- 16 way interface header allows for custom cabling



Assembly instructions:

PUSHMATIC® II mounting devices and card guide are provided to guarantee appropriate assembly.

Accessories are shown on the following pages. PUSHMATIC® II can be used with mounting adaptor and bezels if required by customer design.

C702B Smart Card Connectors PUSHMATIC® II



Description	Contact position	Solenoid voltage	Part No.
PUSHMATIC® II	ISO	5 V	C702 10M008 906 2
without card locking	ISO	12 V	C702 10M008 904 2
	ISO	24 V	C702 10M008 909 2

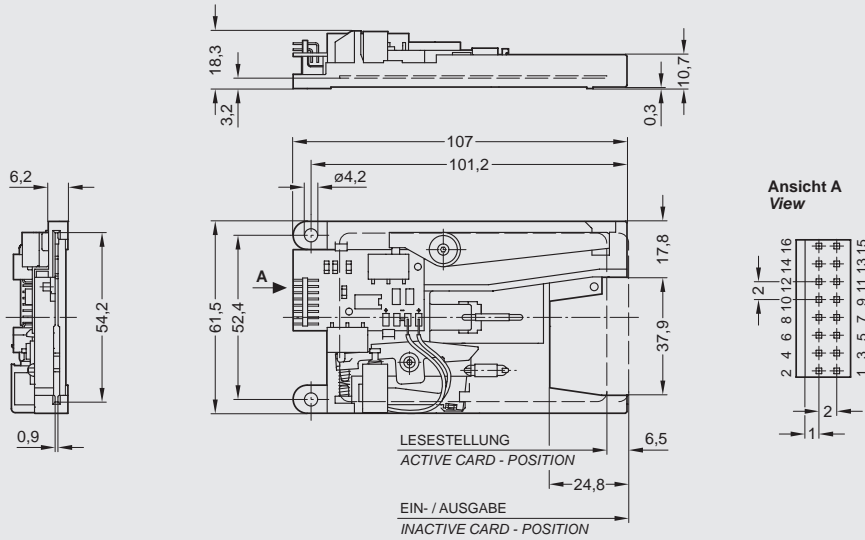

Contact assignment see page 21

C702B Smart Card Connectors PUSHMATIC® II



Description	Contact position	Solenoid voltage	Part No.
PUSHMATIC® II	ISO	5 V	C702 10M008 907 2
with card locking	ISO	12 V	C702 10M008 905 2
	ISO	24 V	C702 10M008 910 2

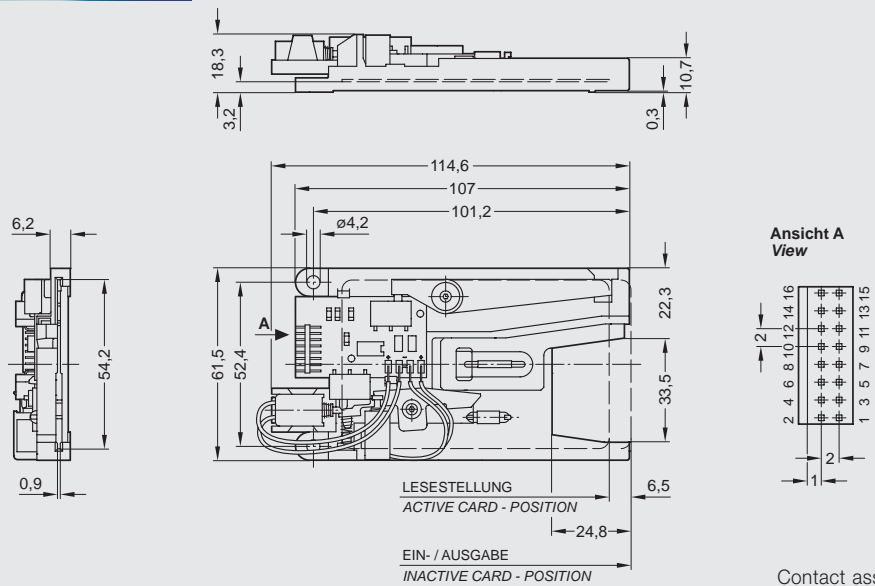

Contact assignment see page 21

C702B Technical Data

Electrical Characteristics contacts

	Standard	Value
Contact resistance	IEC 60512-2, Test 2a	$\leq 100 \text{ m}\Omega$
Insulation resistance	IEC 60512-3, Test 3a	$\geq 10^9 \Omega$
High voltage resistance	IEC 60512-2, Test 4a	500 V _{AC} ; 1 min

Electrical Characteristics connector

Rated voltage		5 V \pm 10%
Current consumption		< 10 mA

Unlocking solenoid

	Version 5 V	Version 12 V	Version 24 V
Rated voltage	5 V \pm 10%	12 V \pm 10%	24 V \pm 10%
Current consumption	$\approx 5.3 \text{ A}$	$\approx 2.2 \text{ A}$	$\approx 1.1 \text{ A}$
Current pulse length	10 ... 25 ms	10 ... 25 ms	10 ... 25 ms
Pulse break	$\geq 1 \text{ s}$	$\geq 1 \text{ s}$	$\geq 1 \text{ s}$

Power failure solenoid (detector)

Rated voltage		5 V \pm 10%	12 V \pm 10%	24 V \pm 10%
Current consumption	initial / holding	$\approx 900 \text{ mA}/270 \text{ mA}$	380 mA/110 mA	$\approx 190 \text{ mA}/55 \text{ mA}$
Current pulse length		< 2 s	< 2 s	< 2 s
Pulse break to 50 °C T _{amb} / over 50 °C T _{amb}		> 10 s / > 30 s	> 10 s / > 30 s	> 10 s / > 30 s

Climatical Characteristics

Climatic category	IEC 60068-1	25 / 70 / 21
Operating temperature		- 25 °C ... + 70 °C
Storage temperature		- 40 °C ... + 85 °C

Mechanical Characteristics

Card insertion force	IEC 60512-7, Test 3b	$\leq 12 \text{ N}$
Mechanical lifetime	IEC 60512-5, Test 9a (without corrosion stress)	300,000 mating cycles
Vibration	IEC 60512-4, Test 6d	f = 10 ... 60 Hz 0,5 mm DA f = 60 ... 500 Hz a = 2.5 g 2 h / axis
Shock, without disconnection	IEC 60512-4, Test 6c	$\leq 40 \text{ g}$; 11 ms; halfsine, 100 / direction in 3 axis
Shock, without destruction	IEC 60512-4, Test 6c	200 g; 6 ms; halfsine, 2 / direction in 3 axis
Contact force		20 ... 60 cN

Switch

Switch	Function	Description
Card presence switch	free from potential, $\leq 5 \text{ ms}$ chattering time	Card detection, card in slot
Card seated switch	TTL high active	Contacts locked, card in active position
EMV-switch	TTL high active	Card in active position, detects early pull out
Chattering time		$\leq 5 \text{ ms}$

Termination

Male connector - 2 x 8 contacts 2 mm pitch	Suitable connector	Female connector 2 x 8 contacts 2 mm pitch
--	--------------------	--

C702B Smart Card Connectors PUSHMATIC® II Accessories

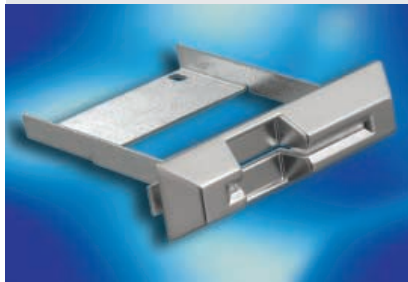

Description

Metal bezel without 'coin spacer', silver coloured
Mounting plate, tin plated

Part No.

C702 G46 000 G2
C702 G51 012 E2

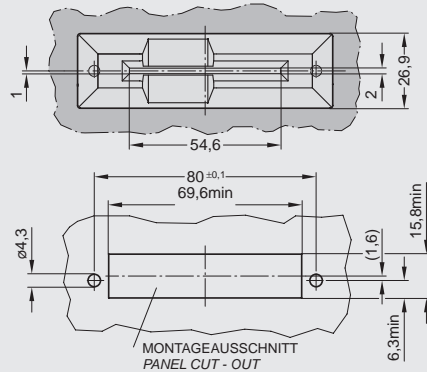

MONTAGEBLECH C702 G51 012 E2:

LIEFERUNG OHNE
- 2 x DIN SCHRAUBE M4 x 6
- 2 x DIN MUTTER M4

EINFÜHRUNGSKRAGEN C702 G46 000 G2:

LIEFERUNG OHNE
- 2 x DIN MUTTER M4

Anzugsdrehmoment für Mutter M4:

- max. 2,5 Nm bei Druckfestigkeit des Werkstoffs am Montageausschnitt > 320 N/mm²
- max. 0,3 Nm bei Druckfestigkeit des Werkstoffs am Montageausschnitt < 320 N/mm²

MOUNTING PLATE C702 G51 012 E2:

DELIVERY WITHOUT
- 2 x DIN SCREW M4 x 6
- 2 x DIN NUT M4

BEZEL C702 G46 000 G2:

DELIVERY WITHOUT
- 2 x DIN NUT M4

starting torque for nut M4:

- max. 2,5 Nm at compression strength of material mounting cut-out > 320 N/mm²
- max. 0,3 Nm at compression strength of material mounting cut-out < 320 N/mm²

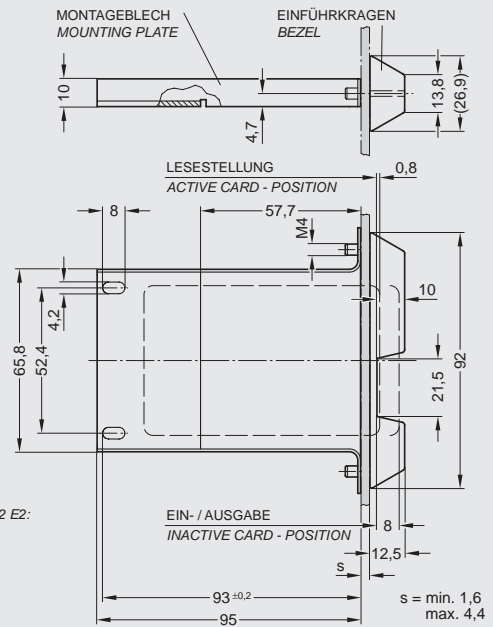

MONTAGE ERFORDERT LESER MIT GESTECKTER KARTE
MAXIMALE ABMESSUNGEN NACH ISO 7810
READER MOUNTING WITH INSERTED CARD OF
MAXIMUM DIMENSIONS ACCORDING TO ISO 7810

C702B Smart Card Connectors PUSHMATIC® II Accessories



Description

Metal bezel with 'coin spacer', silver coloured

Part No.

C702 G46 100 G2

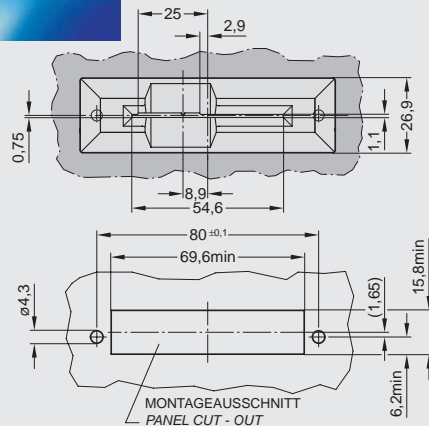

MONTAGEBLECH C702 G51 012 E2:

LIEFERUNG OHNE
- 2 x DIN SCHRAUBE M4 x 6
- 2 x DIN MUTTER M4

EINFÜHRUNGSKRAGEN C702 G46 100 G2:

LIEFERUNG OHNE
- 2 x DIN MUTTER M4

Anzugsdrehmoment für Mutter M4:

- max. 2,5 Nm bei Druckfestigkeit des Werkstoffs am Montageausschnitt > 320 N/mm²
- max. 0,3 Nm bei Druckfestigkeit des Werkstoffs am Montageausschnitt < 320 N/mm²

MOUNTING PLATE C702 G51 012 E2:

WITHOUT
- 2 x DIN SCREW M4 x 6
- 2 x DIN NUT M4

BEZEL C702 G46 100 G2:

WITHOUT
- 2 x DIN NUT M4

starting torque for nut M4:

- max. 2,5 Nm at compression strength of material mounting cut-out > 320 N/mm²
- max. 0,3 Nm at compression strength of material mounting cut-out < 320 N/mm²

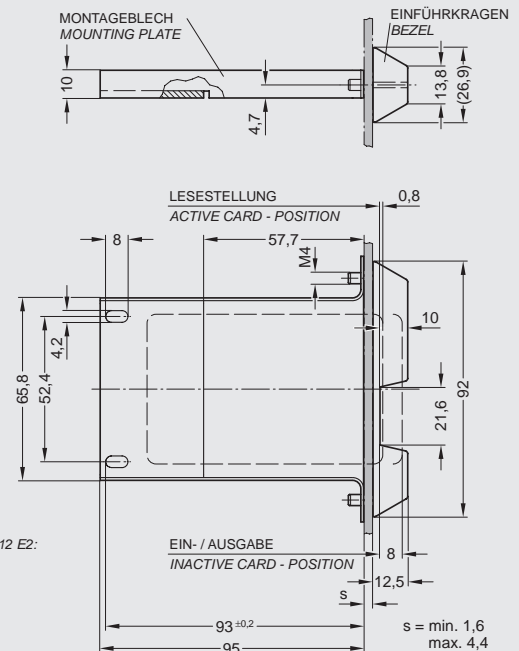

MONTAGE ERFORDERT LESER MIT GESTECKTER KARTE
MAXIMALE ABMESSUNGEN NACH ISO 7810
READER MOUNTING WITH INSERTED CARD OF
MAXIMUM DIMENSIONS ACCORDING TO ISO 7810

C702B Smart Card Connectors PUSHMATIC® II Accessories

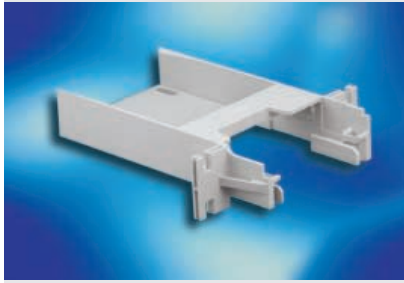

Description	Part No.
Plastic adaptor	C702 N25 040 E2
Adaptor for common standard bezels	

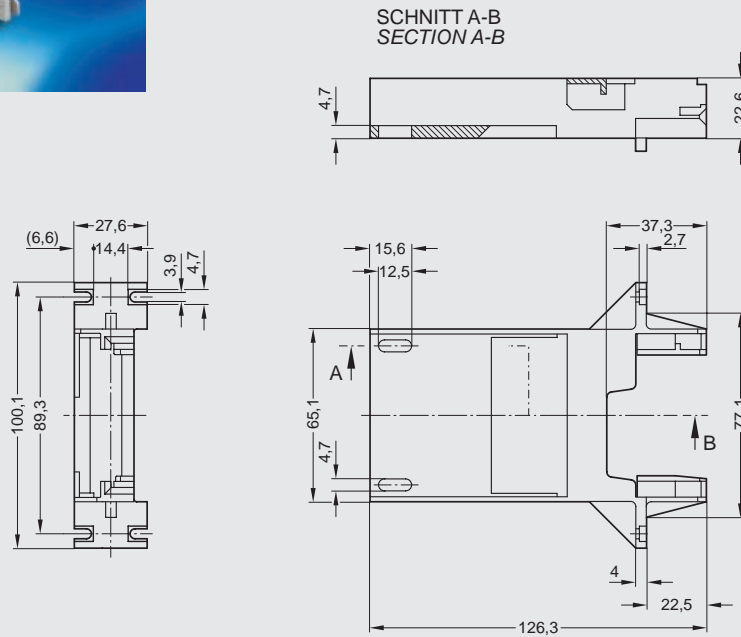

C702B Smart Card Connectors PUSHMATIC® II Contact assignment

Contact assignment, pins in 2 rows, right-angled, 16 contacts

PIN-No.	Contact assignment	Remarks	PIN-No.	Contact assignment	Remarks
PIN 1	M1+	positive power supply unlocking solenoid	PIN 9	C7	I/O-Smart Card
PIN 2	M1-, M2-	negative power supply solenoid	PIN 10	C3	Clk-Smart Card
PIN 3	M2+	positive power supply power failure solenoid	PIN 11	C6	V _{pp} -Smart Card
PIN 4	S1	card presence switch	PIN 12	C2	RST-Smart Card
PIN 5	+5 V	reader supply voltage for PUSHMATIC® II (+5 V)	PIN 13	C5	GND-Smart Card
PIN 6	S1	card presence switch	PIN 14	C1	+5 V-Smart Card
PIN 7	C8	reserved acc. to IEC 7816	PIN 15	S2	card seated switch high active
PIN 8	C4	reserved acc. to IEC 7816	PIN 16	S3	EMV-switch high active

Smart Card Connectors

Low Profile PUSHMATIC®

Series C702C

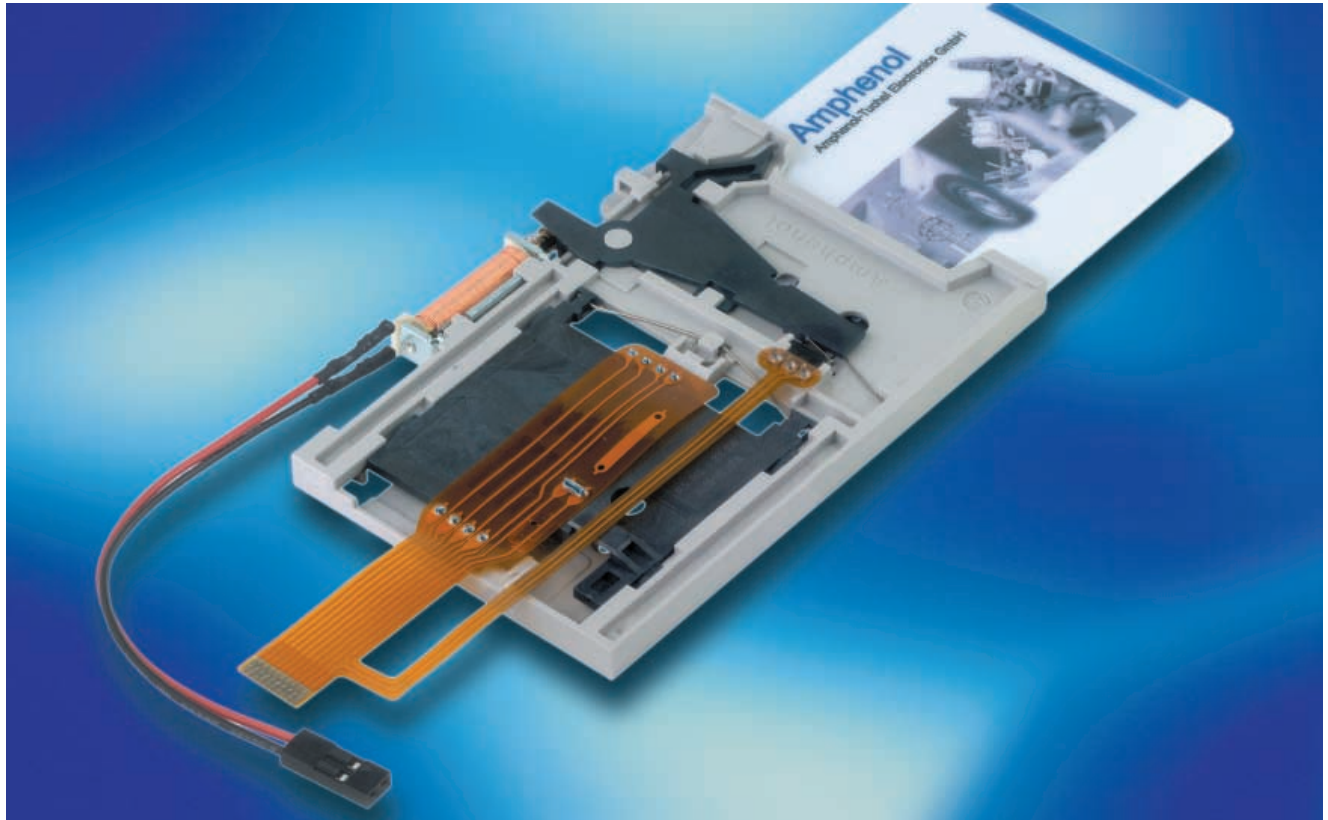

Low Profile PUSHMATIC®

The Smart Card Connector offers a super low profile height to enable the PUSHMATIC®-function also in such places where installation conditions are restricted in size. Main applications are handheld devices and new generations of POS terminals.

Design features

- miniature low profile size
- landing and self-cleaning contact design
- card locking in active position
- card presence switch (normally open) acc. to EMV
- micro switch as locking sensor
- automatic card eject after transaction
- termination to application with flexible pcb
- 2 way solenoid wire including 2.54 mm socket
- manual unlocking after power failure possible
- housing bottom removable to remove foreign debris i.e. coins (optional)



Assembly instructions:

For correct assembly please refer to the instructions on the next page. Please make sure that flexprints remain free and unrestricted after assembly.

C702C Smart Card Connectors Low Profile PUSHMATIC®

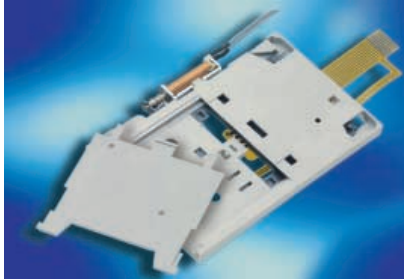
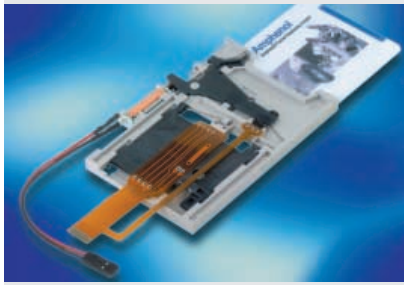

Description	Contact position	Solenoid voltage	Part No.
Low Profile PUSHMATIC®	ISO	5V	C702 10M008 901 4
	ISO	12V	C702 10M008 902 4
	ISO	24V	C702 10M008 903 4

Debris slot by removing of base plate.

SCHALTER FÜR
KARTENANWESENHEIT UND
VERRIEGELUNG IN REIHE
CARD PRESENCE SWITCH
AND LOCKING DETECTOR
IN SERIES

Ansicht X
View

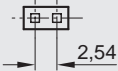

BUCHSENLEISTE FÜR
PFOSTENVERBINDER
SOCKET FOR HEADER
0,63 x 0,63

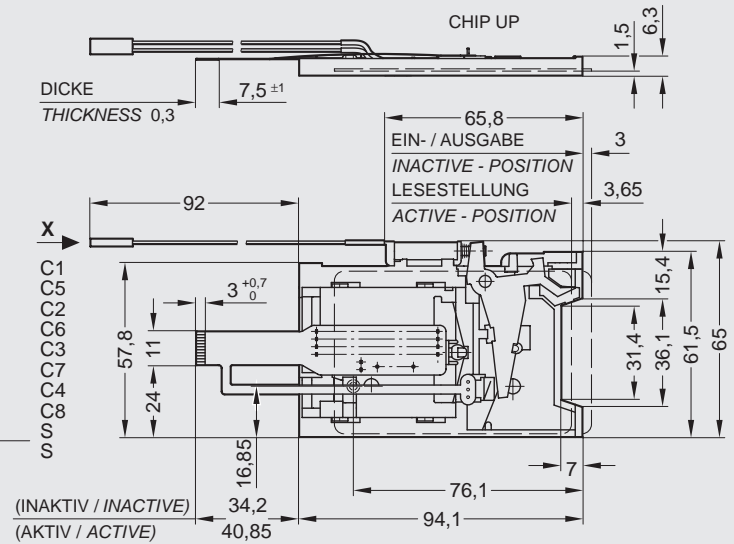
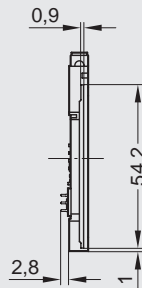

MONTAGEHINWEIS FÜR KUNDEN
CUSTOMER ASSEMBLY INSTRUCTIONS



MINIMALE GERÄTESEITIGE ABSTÜTZUNG
MINIMUM REQUIRED SUPPORT BY CUSTOMER TERMINAL

PUSHMATIC LOW PROFILE MIT ENTSORGUNGSSCHACHT
(BODEN ENTFERNT)
PUSHMATIC LOW PROFILE WITH DEBRIS SLOT (BASE PLATE REMOVED)

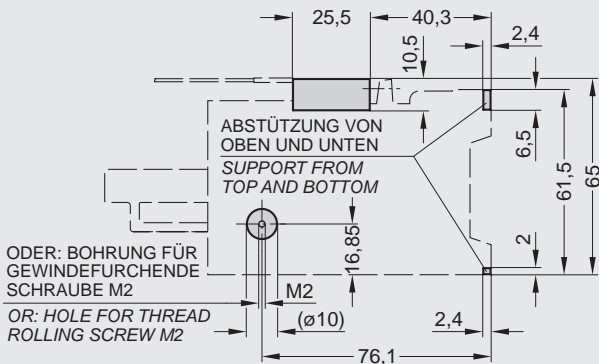

PUSHMATIC LOW PROFILE OHNE ENTSORGUNGSSCHACHT
PUSHMATIC LOW PROFILE WITHOUT DEBRIS SLOT

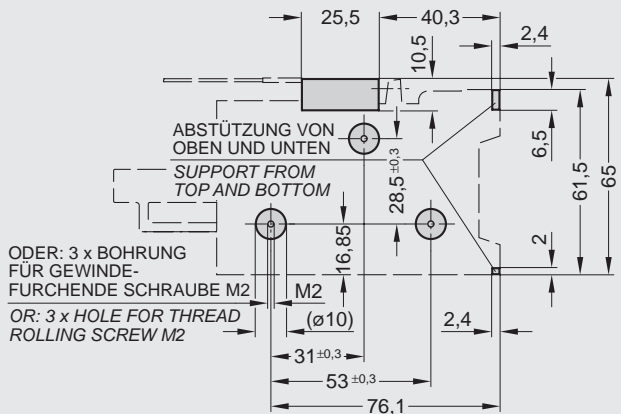

C702C Technical Data

Electrical Characteristics	Standard	Value
Contact resistance	IEC 60512-2, Test 2a	$\leq 100 \text{ m}\Omega$
Insulation resistance	IEC 60512-3, Test 3a	$\geq 10^9 \Omega$
High voltage resistance	IEC 60512-2, Test 4a	500 V _{AC} ; 1 min

Unlocking solenoid	Version 5 V	Version 12 V	Version 24 V
Rated voltage	5 V \pm 10%	12 V \pm 10%	24 V \pm 10%
Current consumption	$\approx 2.6 \text{ A}$	$\approx 1.5 \text{ A}$	$\approx 1.0 \text{ A}$
Current pulse length	10 ... 30 ms	10 ... 30 ms	10 ... 30 ms
Pulse break	$\geq 1 \text{ s}$	$\geq 1 \text{ s}$	$\geq 1 \text{ s}$

Climatical Characteristics (Preliminary)

Climatic category	IEC 60068-1	20 / 60 / 21
Operating temperature	without condensation	- 20 °C ... + 60 °C
Storage temperature		- 40 °C ... + 85 °C

Mechanical Characteristics (Preliminary)

Card insertion force	IEC 60512-7, Test 13b	$\leq 10 \text{ N}$
Mechanical lifetime	IEC 60512-5, Test 9a (without corrosion stress)	300,000 mating cycles
Vibration	IEC 60512-4, Test 6d	f = 4 ... 11.2 Hz 10 mm DA f = 11.2 ... 500 Hz a = 5 g 2 h / axis
Shock, without disconnection	IEC 60512-4, Test 6c	$\leq 40 \text{ g}$; 6 ms; halfsine 100 shocks / direction in 3 axis
Shock, without destruction	IEC 60512-4, Test 6c	500 g; 1 ms; halfsine 2 shocks / direction in 3 axis
Contact force		20 ... 50 cN

Switch	Description	Function
Card presence switch and locking detector in series	Card detection, card in slot Contacts locked, card in active position	free from potential; $\leq 10 \text{ ms}$ chattering time
Switching capacity		max. 12 V / 50 mA (200,000 switching cycles) min. 5 V / 0.1 mA (300,000 switching cycles)

Termination

Suitable connector

Flexprint 10 contacts; 1 mm pitch	Flexprint connector 10 contacts; 1 mm pitch; see page 29 «Accessories Flexprint Connectors»
-----------------------------------	--

Smart Card Connectors

Superflat Style

Series C702D

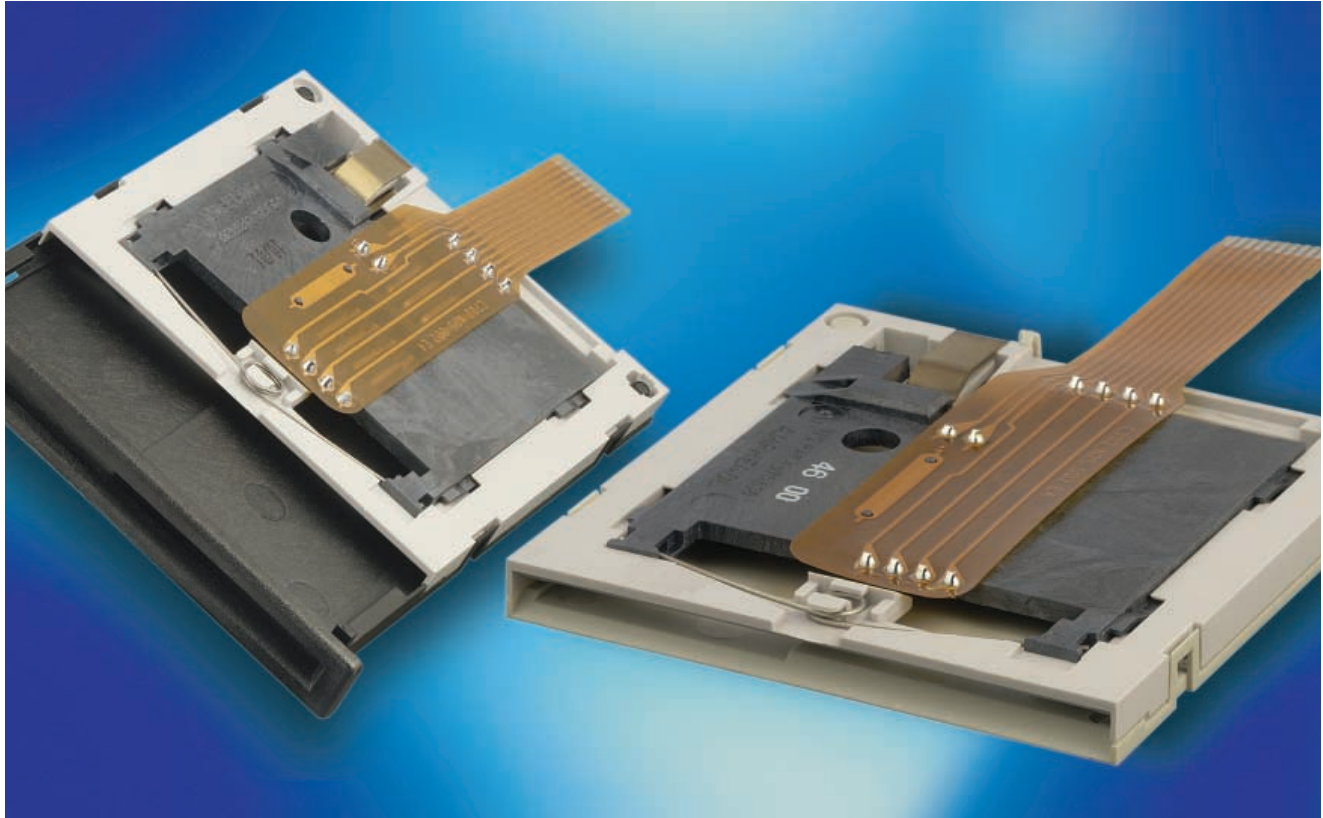

Standard Page 26



with card guide Page 26



Push-Lift Page 27



with board locks dip solder Page 27



with board locks Page 28



Accessories Flexprint connectors Page 29

Superflat Style Smart Card Connector

is a Push-Pull Series of 2nd generation connectors with landing contacts providing a high degree of miniaturization. Suitable applications include: point-of-sales systems, mobile devices, access control, keyboards, etc.

Design features

- miniature size ideally suited for mobile devices
- additional space saving possible by integration of base into customer housing
- Versions acc. to EMV (see page 6)
- dip solder version available featuring snap-in mounting, chip side up card insertion, and a debris slot to provide egress of coins, paper, etc.
- snap-in version also available with flexprint termination (both SMT and PCB)



Assembly instructions:

Please make sure that flexprints remain free and unrestricted after assembly.

C702D Smart Card Connectors Superflat Style

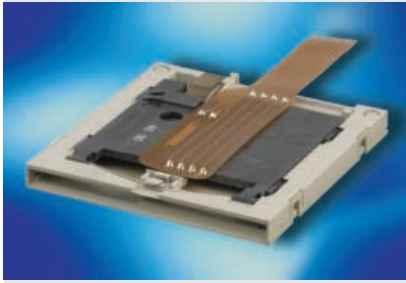

Description	Contact position	Part No.
Standard	ISO	C702 10M008 001 4
Standard, acc. to EMV	ISO	C702 10M008 065 4



Assembly instructions:
To protect the reader please provide a card guide.

LESESTELLUNG
ACTIVE POSITION

EMPFOHLENER
FRONTPLATTENAUSSCHNITT
RECOMMENDED
FRONT PANEL CUT OUT

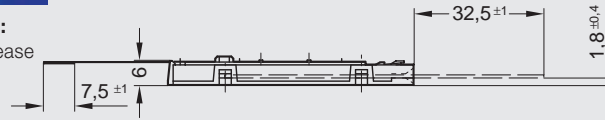

SENKUNG FÜR SENKSCHRAUBE M2
FOR FLAT HEAD COUNTERSUNK SCREW

EIN- / AUSGABE
INACTIVE POSITION

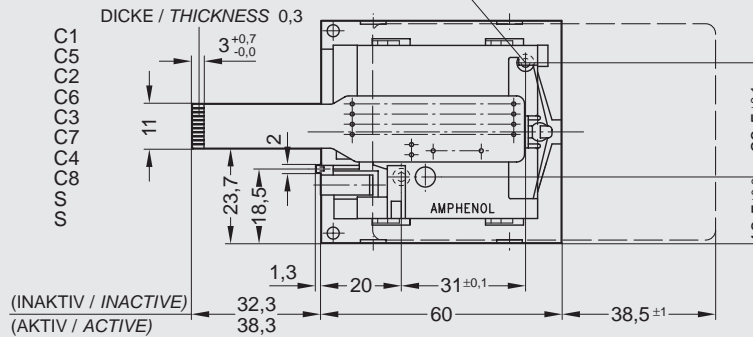
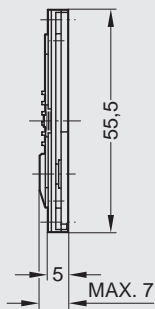

C702D Smart Card Connectors Superflat Style

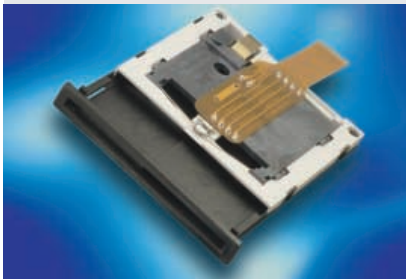

Description	Contact position	Part No.
with card guide	ISO	C702 10M008 023 4

LESESTELLUNG
ACTIVE POSITION

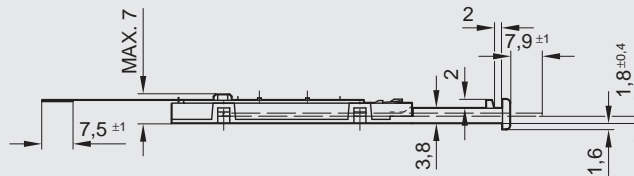

SENKUNG FÜR SENKSCHRAUBE M2
FOR FLAT HEAD COUNTERSUNK SCREW

EIN- / AUSGABE
INACTIVE POSITION

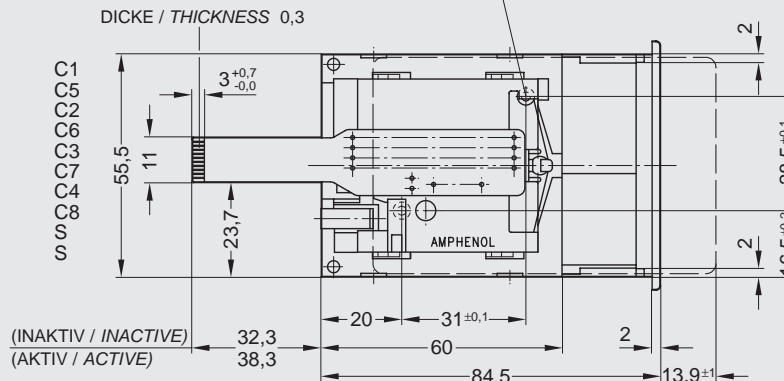
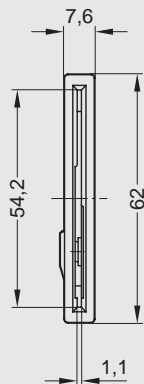

C702D Smart Card Connectors Superflat Style



Description	Contact position	Part No.
Push-Lift, acc. to EMV	ISO	C702 10M008 040 4

LESESTELLUNG
ACTIVE POSITION

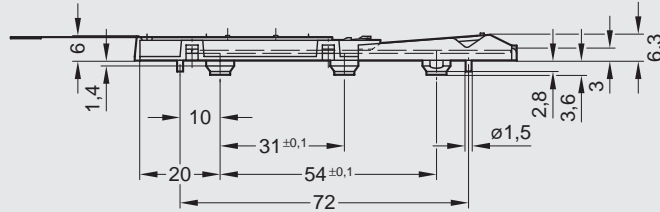

EIN- / AUSGABE
INACTIVE POSITION

SENKUNG FÜR ZYLINDERSCHRAUBE M2 DIN 84
FOR FILLISTER HEAD SCREW

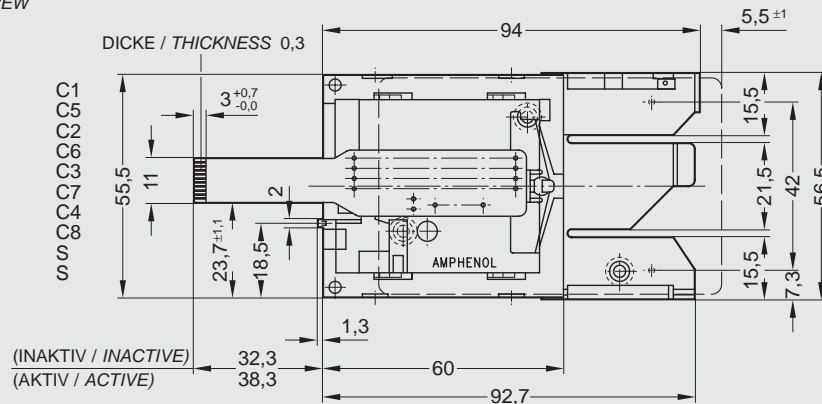
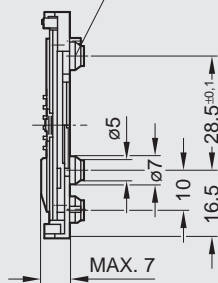

C702D Smart Card Connectors Superflat Style



Description	Contact position	Part No.
with board locks, dip solder	ISO	C702 10M008 060 4
with board locks, dip solder, acc. to EMV	ISO	C702 10M008 063 4

LESESTELLUNG
ACTIVE POSITION

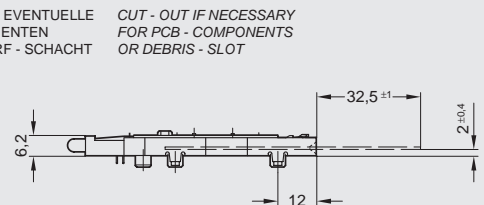

ÖFFNUNG FÜR EVENTUELLE
PCB - KOMPONENTEN
ODER AUSWURF - SCHACHT
CUT - OUT IF NECESSARY
FOR PCB - COMPONENTS
OR DEBRIS - SLOT

DETAIL X
EINZELHEIT X

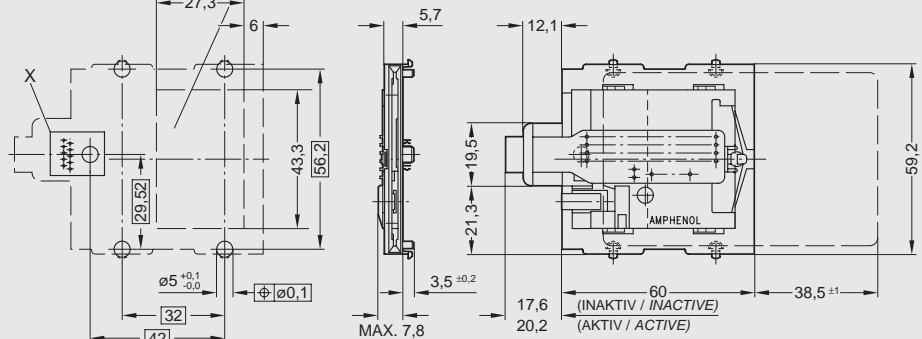
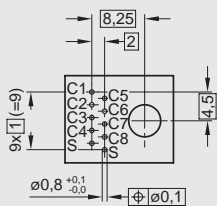

EIN- / AUSGABE
INACTIVE POSITION

C702D Smart Card Connectors Superflat Style

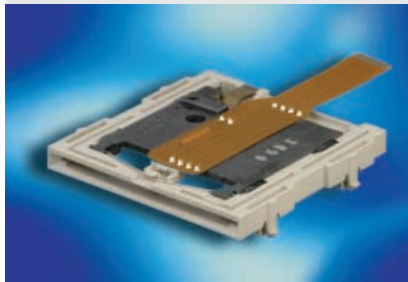

Description	Contact position	Part No.
with board locks	ISO	C702 10M008 061 4
with board locks, acc. to EMV	ISO	C702 10M008 066 4

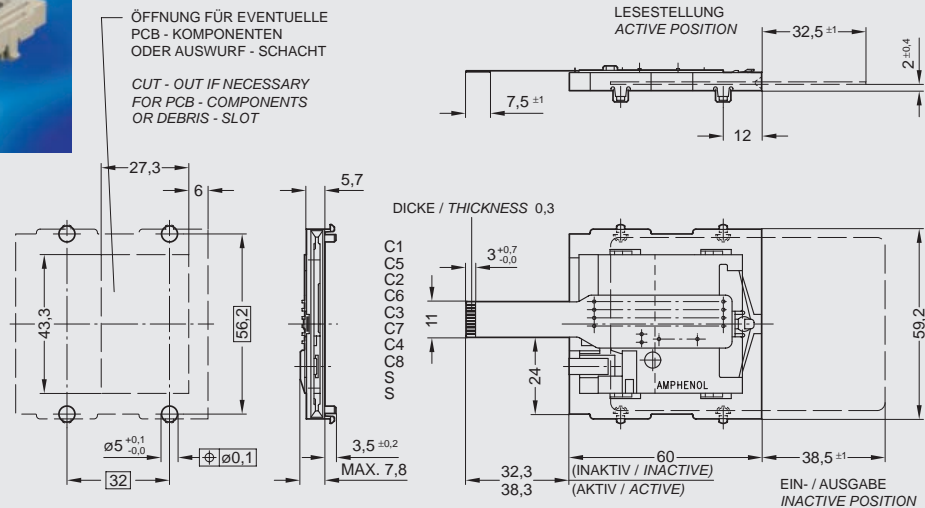

C702D Technical Data

Electrical Characteristics	Standard	Value
Contact resistance without cable or flexprint	IEC 60512-2, Test 2a	Data contacts $\leq 30 \text{ m}\Omega$ Switch contacts $\leq 40 \text{ m}\Omega$
Insulation resistance	IEC 60512-2, Test 3a	$\geq 10^9 \Omega$
High voltage resistance	IEC 60512-2, Test 4a	500 V _{AC} ; 1 min

Climatical Characteristics

Climatic category	IEC 60068-1	25 / 65 / 56
Operating temperature		- 25 °C ... + 65 °C
Storage temperature		- 40 °C ... + 85 °C

Mechanical Characteristics

	Standard	Standard	EMV-Version
Card insertion force standard	IEC 60512-7, Test 13b	$\leq 8 \text{ N}$	$\leq 10 \text{ N}$
Card extraction force standard	IEC 60512-7, Test 13b	$\geq 3 \text{ N}$	$\geq 2 \text{ N}$
Mechanical lifetime	IEC 60512-5, Test 9a (without corrosion)	300,000 mating cycles	
Vibration	IEC 60512-4, Test 6d	f = 10 ... 60 Hz f = 60 ... 500 Hz 2 h / axis	0.7 mm DA a = 5 g
Shock, without disconnection	IEC 60512-4, Test 6c	$\leq 40 \text{ g}$; 6 ms; halfsine 12 shocks / direction in 3 axis	
Shock, without destruction	IEC 60512-4, Test 6c	200 g; 6 ms; halfsine 2 shocks / direction in 3 axis	
Contact force		20 ... 50 cN	

Switch

Function

Card presence switch		normally open
Switch sequence	The card presence switch is activated after the data contacts have mated with the card pads and before the card reaches its final position. This sequence will take place for the minimum sized card pads (and larger) acc. to ISO 7816.	
Chattering time		$\leq 5 \text{ ms}$

Termination

Suitable connector

Connector for flexprint		see page 29
No. of contacts 8 or 10		«Accessories Flexprint Connectors»

C007 Smart Card Connectors Accessories Flexprint Connectors

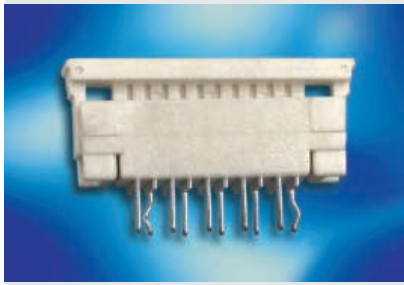

Termination	No. of contacts	Part No.
dip solder pin straight	8	C007 10B008 000 1
dip solder pin straight	10	C007 10B010 000 1

Further versions upon request

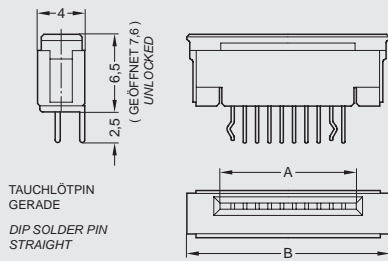

Termination	No. of contacts	Part No.
dip solder pin 90° angle	8	C007 10B008 100 1
dip solder pin 90° angle	10	C007 10B010 100 1

Further versions upon request

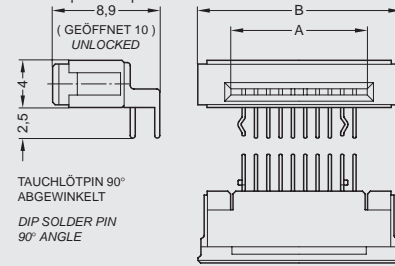

C007 Smart Card Connectors Accessories Flexprint Connectors



Termination	No. of contacts	Part No.
SMT straight	8	C007 10B008 100 2
SMT straight	10	C007 10B010 100 2

Further versions upon request

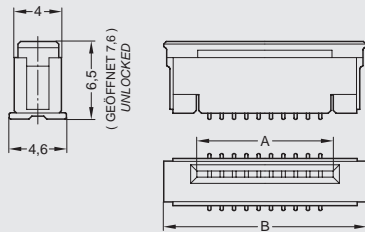

Termination	No. of contacts	Part No.
SMT 90° angle	8	C007 10B008 000 2
SMT 90° angle	10	C007 10B010 000 2

Further versions upon request

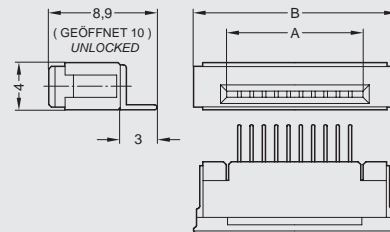

LOCHBILD FÜR LEITERPLATTE (TAUCHLÖTPIN)
DIP SOLDER PCB - LAYOUT

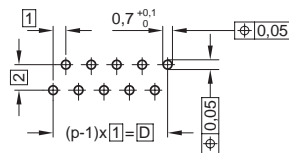

LAYOUT FÜR LEITERPLATTE (SMT)
SMT PCB - LAYOUT

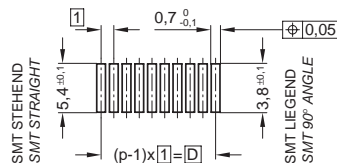

No. of contacts p	A	B	D
10	11.1	16.5	9
8	9.1	14.5	7

KONTAKTBELEGUNG: FLEXPRINT - LAYOUT

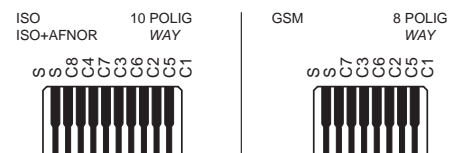

S = KARTENANWESENHEITSSCHALTER / CARD PRESENCE SWITCH
C1 ... C8 = LESEKONTAKTE / READING CONTACTS

C007 Technical Data

Electrical Characteristics	Standard	Value
Contact resistance	IEC 60512-2, Test 2a	$\leq 20 \text{ m}\Omega$
Current carrying capacity	IEC 60512-3, Test 5b	0.5 A per contact at 70 °C
Rated voltage	IEC 60664-1	63 V
Rated impulse withstand voltage	IEC 60664-1	0.8 KV
Pollution degree	IEC 60664-1	1
Installations (overvoltage) category	IEC 60664-1	II
Comparative tracking index	IEC 60664-1	CTI 175

Climatical Characteristics

Temperature		- 40 °C to + 85 °C at 75% relative humidity
Reflow temperature		$\leq 240 \text{ °C} / 15 \text{ s}$

Mechanical Characteristics

Thickness of flexprint		Thickness 0.3 mm \pm 0.05 mm
Pitch of flexprint		1.0 mm
Pitch of PCB		page 30

Materials

Contact body		LCP
Contact spring		CuSn
Contact plating		tinned

Smart Card Connectors with PCB Mount Wiping Contacts

Series C702E



with board locks, dip solder pins and self-cleaning switch Page 32



with board locks, dip solder pins, 3 mm stand-offs and self-cleaning switch Page 32



with board locks, dual plane, 2 x 8 contacts, dip solder pins and self-cleaning switch Page 33



with board locks, dip solder pins, 3 mm stand-offs, self-cleaning switch and card guide Page 33



with board locks, dip solder pins, self-cleaning switch and card guide Page 34



with board locks, dip solder pins, self-cleaning switch, "double decker" Page 34,35



Screw/Rivet mounting Page 36



with board locks and dip solder pins Page 36



with board locks, SMT and self-cleaning switch Page 37



with board locks, SMT, self-cleaning switch and card guide Page 37



with board locks, dip solder pins, self-cleaning switch and card guide Page 38

PCB Mount Wiping Contact Smart Card Connectors

Typical applications for Smart Card Connectors with wiping contacts and PCB mounting are set top boxes, toll road transponders, parking meters, utility metering systems, etc., where limited numbers of mating cycles are specified.

Design features

- Termination: dip solder pins or SMT
- self-cleaning card presence switch on most models detecting final card position
- special shape of wiping contacts minimize card scratching and wear
- Versions acc. to EMV (see page 6)
- dual plane version with 2 x 8 contacts for chip up & down card handling, suitable for applications with short dwell time of the card



Assembly instructions:

Soldering conditions

- wave soldering: 260 °C; 10 s max.
- infrared reflow 230 °C; 30 s max. (SMT versions only)

C702E Smart Card Connectors with PCB Mount Wiping Contacts

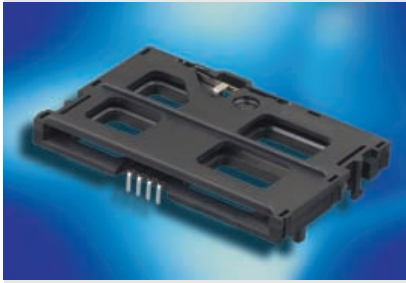

Description	Contact position	Termination	Part No.
with board lock and self-cleaning switch, acc. to EMV	ISO	Dip solder pin	C702 10M008 272 4

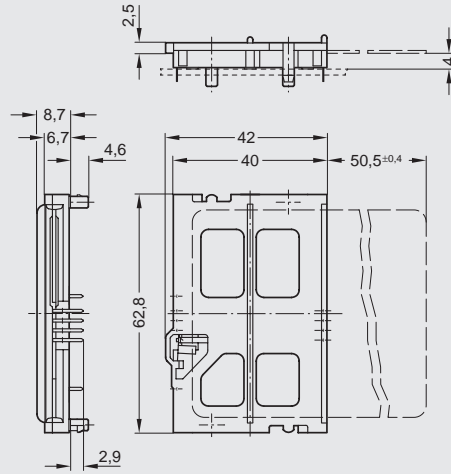

BESTÜCKUNGSSEITE / COMPONENTS SIDE

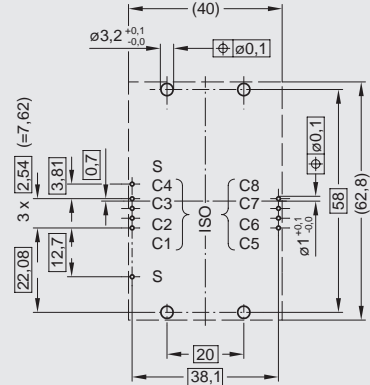

LEITERPLATTENDICKE / PCB THICKNESS = 1,4 - 1,68

C702E Smart Card Connectors with PCB Mount Wiping Contacts



Description	Contact position	Termination	Part No.
with board lock and self-cleaning switch and 3 mm stand-offs, acc. to EMV	ISO	Dip solder pin	C702 10M008 255 4

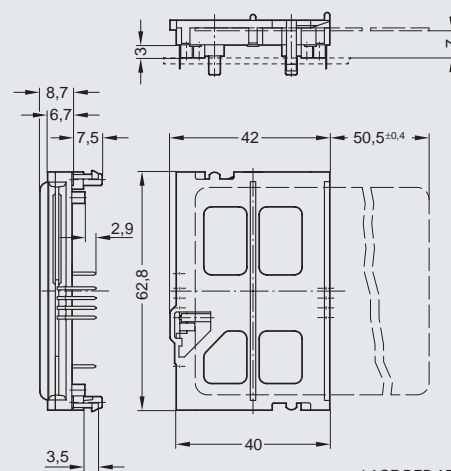

BESTÜCKUNGSSEITE / COMPONENTS SIDE

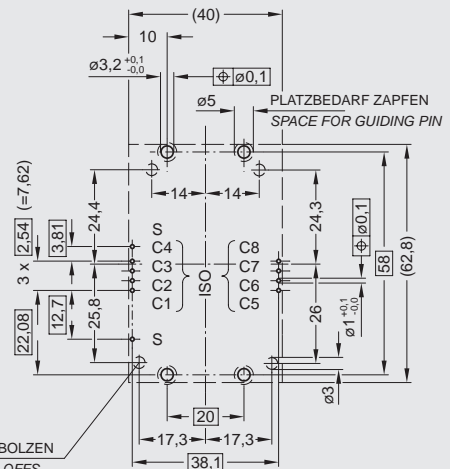

LAGE DER ABSTANDSBOLZEN
POSITION OF STAND-OFFS

LEITERPLATTENDICKE / PCB THICKNESS = 1,4 - 1,68

C702E Smart Card Connectors with PCB Mount Wiping Contacts



Description	Contact position	Termination	Part No.
with board lock and self-cleaning switch, dual plane, 2 x 8 contacts, acc. to EMV	ISO (Data contacts top and bottom side)	Dip solder pin	C702 10M008 271 4

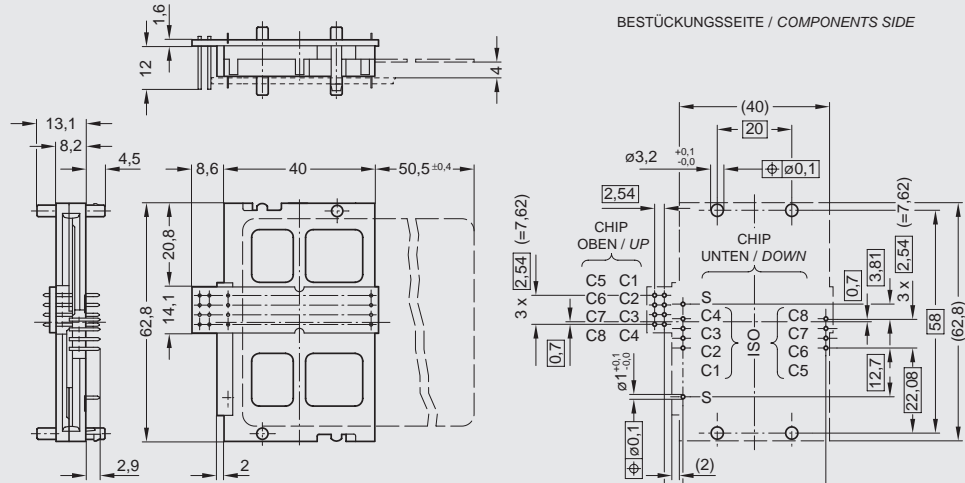

Kondensator 0,1 μ F zwischen C1 (VCC) und C5 (GND) bei Kartenlage Chip oben
Capacitor 0,1 μ F between C1 (VCC) and C5 (GND) in card position chip up

LEITERPLATTENDICKE / PCB THICKNESS = 1,4 ... 1,68

C702E Smart Card Connectors with PCB Mount Wiping Contacts



Description	Contact position	Termination	Part No.
with board lock, self-cleaning switch and card guide, 3 mm stand-offs, acc. to EMV	ISO	Dip solder pin	C702 10M008 283 4

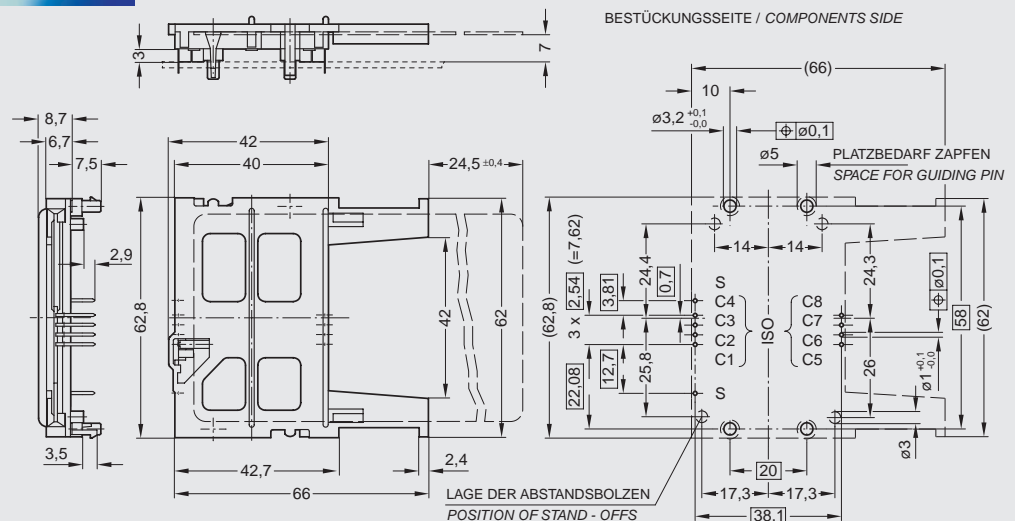

LEITERPLATTENDICKE / PCB THICKNESS = 1,4 - 1,68

C702E Smart Card Connectors with PCB Mount Wiping Contacts



Description	Contact position	Termination	Part No.
with board lock, self-cleaning switch and card guide, acc. to EMV	ISO	Dip solder pin	C702 10M008 286 4

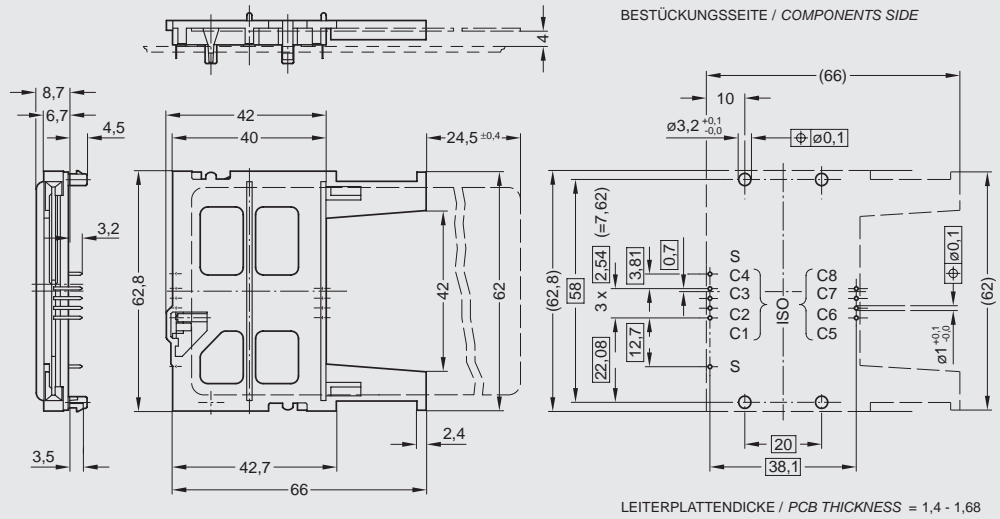

C702E Smart Card Connectors with PCB Mount Wiping Contacts



Description	Contact position	Termination	stand off	dim. A	dim. B	Part No.
double decker	ISO	Dip solder pin	-	15.7 mm	3.9 mm	C702 10M008 278 4
with board lock and self cleaning switch	ISO	Dip solder pin	3 mm	18.7 mm	6.9 mm	C702 10M008 279 4
	ISO	Dip solder pin	-	20.5 mm	3.9 mm	C702 10M008 295 4

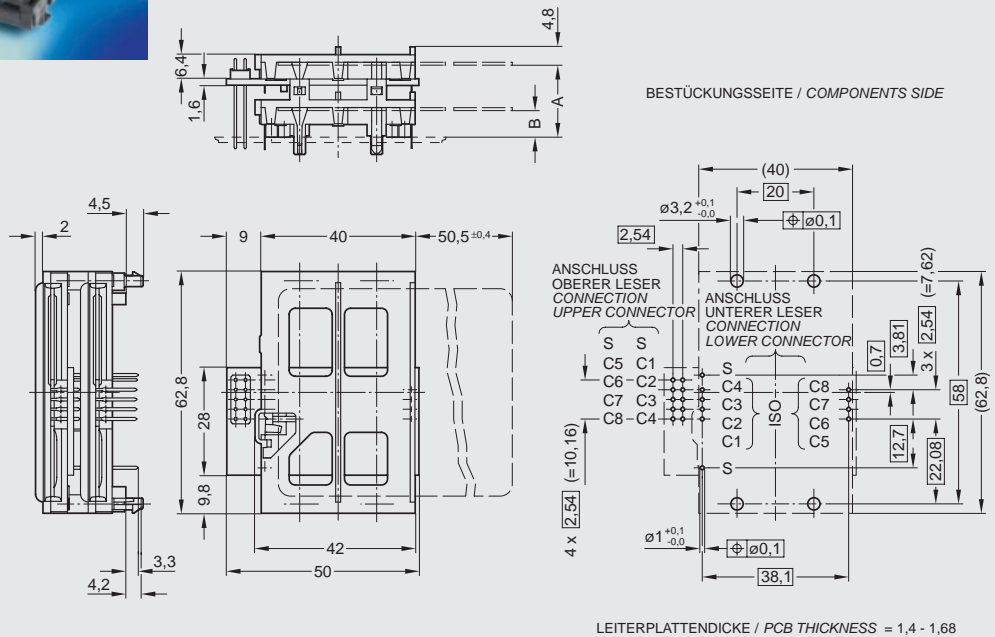

C702E Smart Card Connectors with PCB Mount Wiping Contacts



Description	Contact position	Termination	Part No.
double decker, with board lock and self cleaning switch, 5mm overhang, bottom part for double thickness cards, upper part, dual plan 2x8 contacts	ISO	Dip solder pin	C702 10M008 290 4

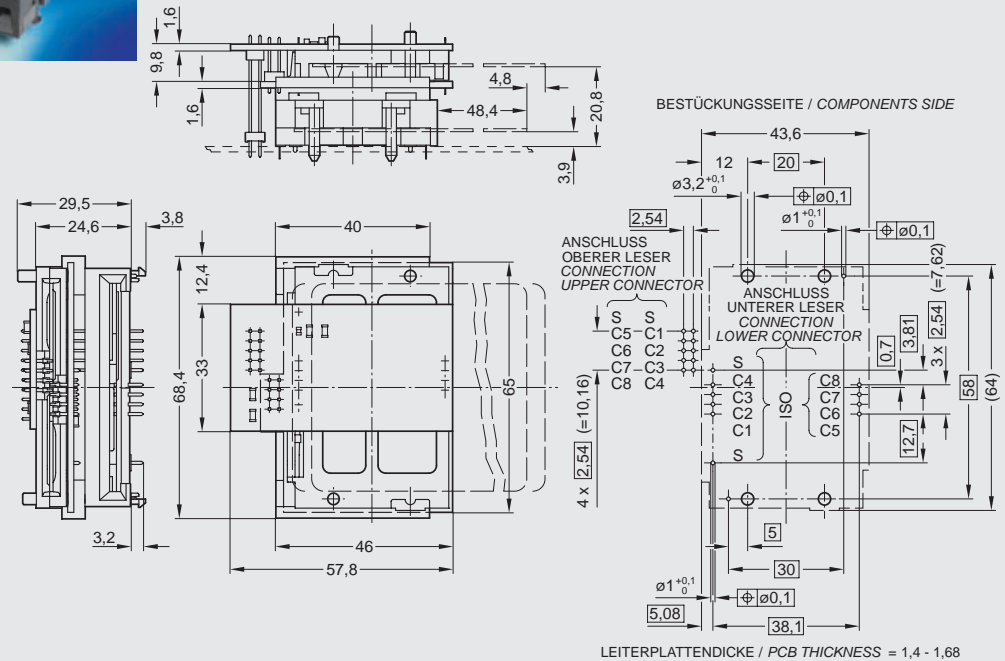

C702E Smart Card Connectors with PCB Mount Wiping Contacts



Description	Contact position	Termination	Part No.
double decker, with board lock and self cleaning switch, bottom part for double thickness cards, upper part, dual plan 2x8 contacts	ISO	Dip solder pin	C702 10M008 294 4

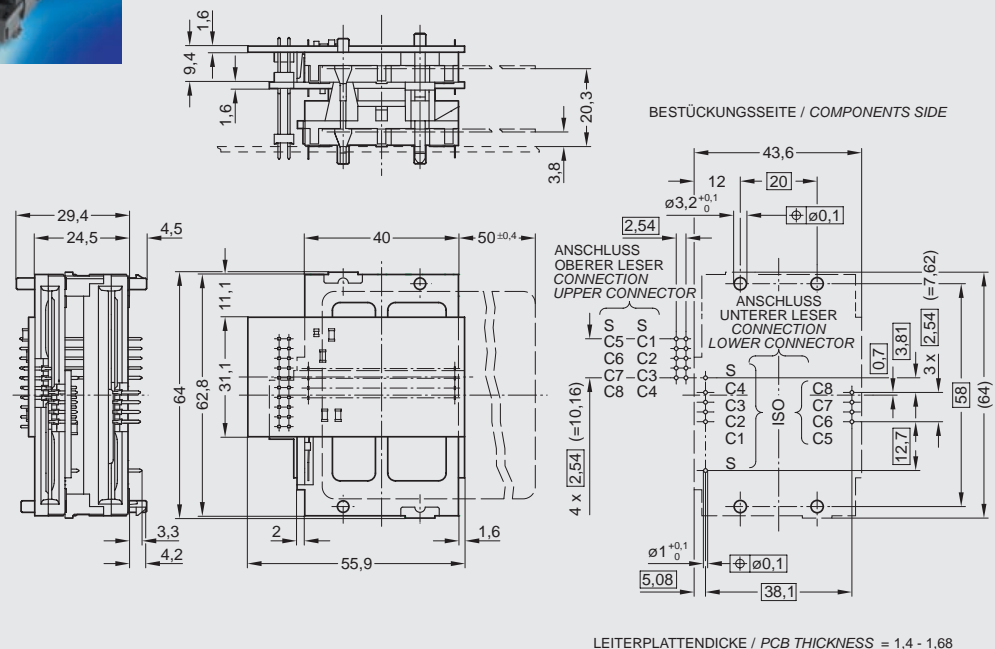

C702E Smart Card Connectors with PCB Mount Wiping Contacts



Description	Contact position	Termination	Part No.
Screw /	ISO	Dip solder pin	C702 10M008 201 4
Rivet mounting	AFNOR	Dip solder pin	C702 10M008 202 4
	ISO + AFNOR	Dip solder pin	C702 10M008 203 4

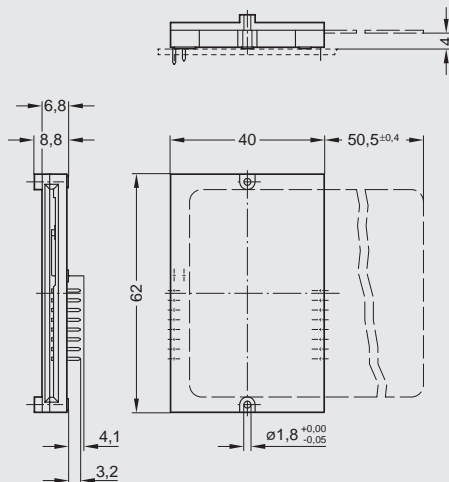

BESTÜCKUNGSSEITE / COMPONENTS SIDE

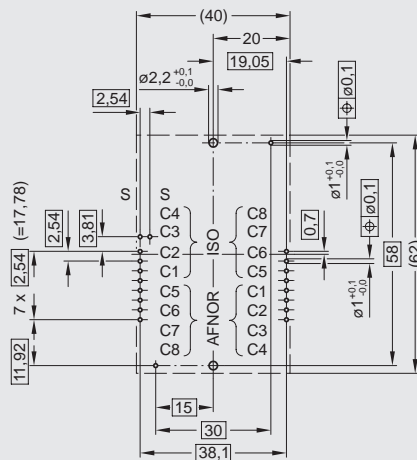

LEITERPLATTENDICKE / PCB THICKNESS = 1,6 ... 2,4

C702E Smart Card Connectors with PCB Mount Wiping Contacts



Description	Contact position	Termination	Part No.
with board lock	ISO	Dip solder pin	C702 10M008 206 4
	AFNOR	Dip solder pin	C702 10M008 207 4
	ISO + AFNOR	Dip solder pin	C702 10M008 205 4

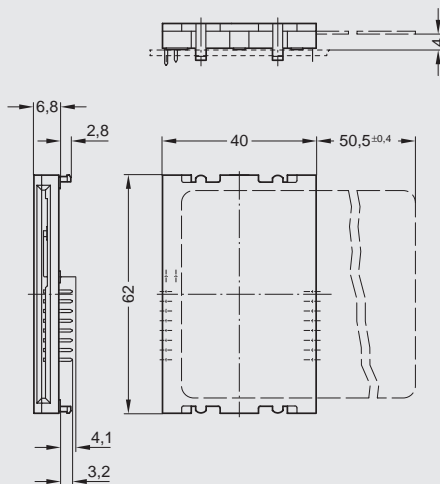

BESTÜCKUNGSSEITE / COMPONENTS SIDE

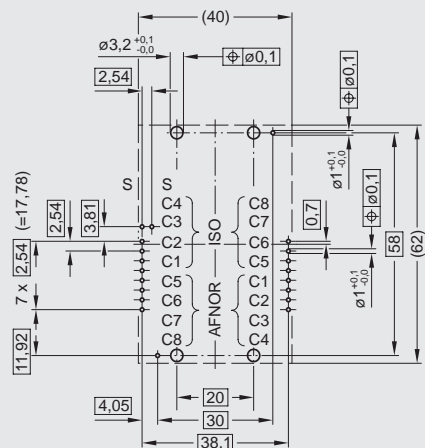

LEITERPLATTENDICKE / PCB THICKNESS = 1,4 ... 1,68

C702E Smart Card Connectors with PCB Mount Wiping Contacts



Description	Contact position	Termination	Part No.
with board lock and self-cleaning switch	ISO	SMT	C702 10M008 244 4

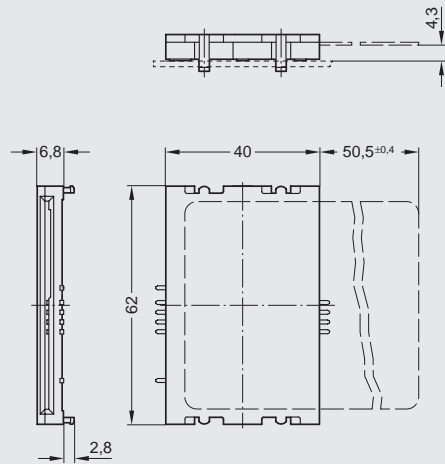

BESTÜCKUNGSSEITE / COMPONENTS SIDE

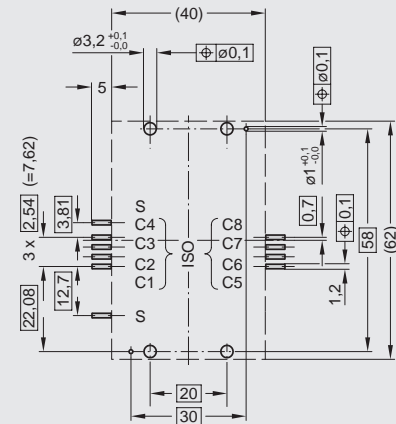

LEITERPLATTENDICKE / PCB THICKNESS = 1,4 - 1,68

C702E Smart Card Connectors with PCB Mount Wiping Contacts



Description	Contact position	Termination	Part No.
with board lock, self-cleaning switch and card guide	ISO	SMT	C702 10M008 230 4
	ISO + AFNOR	SMT	C702 10M008 224 4

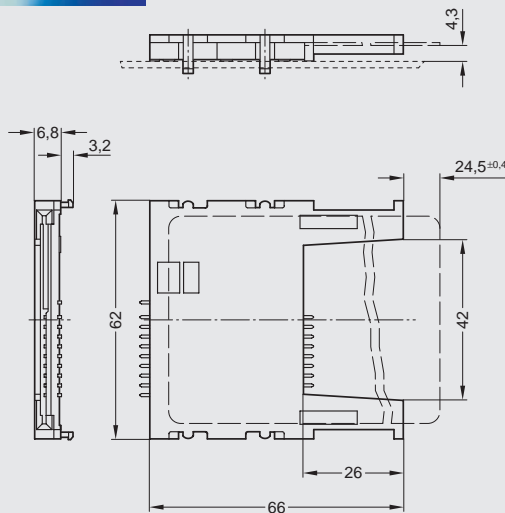

BESTÜCKUNGSSEITE / COMPONENTS SIDE

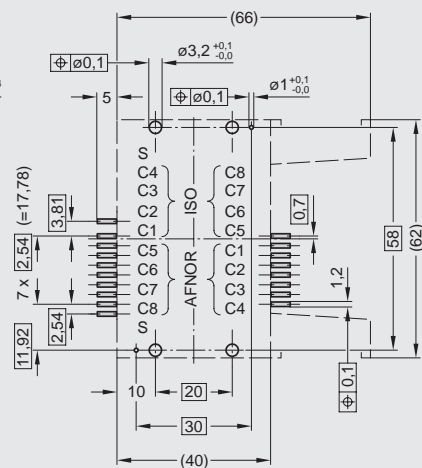

LEITERPLATTENDICKE / PCB THICKNESS = 1,4 - 1,68

C702E Smart Card Connectors with PCB Mount Wiping Contacts



Description	Contact position	Termination	Part No.
with board lock,	ISO	Dip solder pin	C702 10M008 226 4
self-cleaning switch and card guide	ISO + AFNOR	Dip solder pin	C702 10M008 235 4

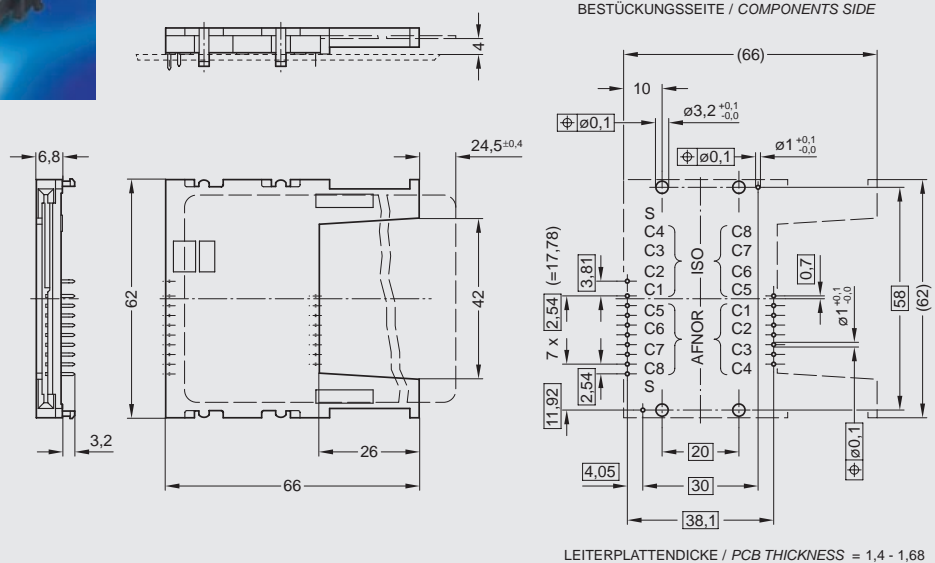

C702E Technical Data

Electrical Characteristics	Standard	Value
Contact resistance without cable or flexprint	IEC 60512-2, Test 2a	Data contacts ≤ 30 mΩ Switch contacts ≤ 50 mΩ
Insulation resistance	IEC 60512-2, Test 3a	≥ 10 ⁹ Ω
High voltage resistance	IEC 60512-2, Test 4a	500 V _{AC} ; 1 min

Climatical Characteristics

Climatic category	IEC 60068-1	25 / 70 / 21
Operating temperature		- 25 °C ... + 70 °C
Storage temperature		- 40 °C ... + 85 °C

Mechanical Characteristics

Card insertion force	IEC 60512-7, Test 13b	≤ 5 N	≤ 12 N at "dual plane" 2 x 8 contacts
Card extraction force	IEC 60512-7, Test 13b	≥ 1 N	
Mechanical lifetime	IEC 60512-5, Test 9a (without corrosion stress)	100,000 mating cycles	
Vibration	IEC 60512-4, Test 6d	f = 10 ... 60 Hz 0,35 mm DA f = 60 ... 500 Hz a = 2.5 g 2 h / axis	
Shock, without disconnection	IEC 60512-4, Test 6c	≤ 40 g; 11 ms; halfsine 3 shocks / direction in 3 axis	
Shock, without destruction	IEC 60512-4, Test 6c	200 g; 6 ms; halfsine 2 shocks / direction in 3 axis	
Contact force		20 ... 50 cN	

Switch

Card presence switch		normally closed
Switch sequence	The card presence switch is activated after the data contacts have mated with the contact field and before the card reaches its final position.	
Chattering time		≤ 5 ms

Smart Card Connectors

with landing card PCB Mount

Series C702F

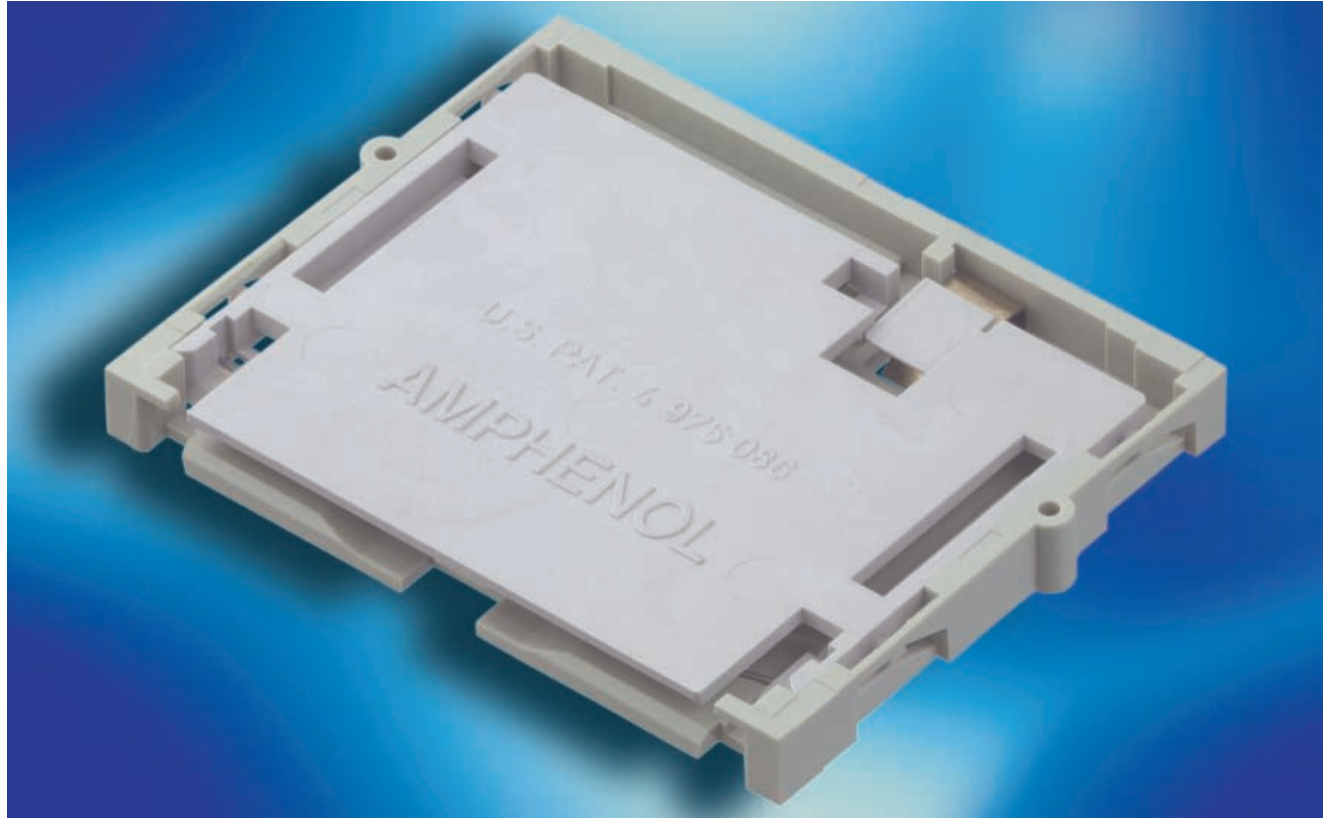

The Smart Card Connector with landing card. Typical applications are Point-of-Sale systems, mobile devices, access control etc.

Design features

- high number of mating cycles due to minimized wiping distance on card contacts
- contact self-cleaning effect
- short card insertion depth



Assembly instructions:

For the provided Philip's head screws, a power driven screw driver (500-600 r/rpm; 0.25 Nm max.) is recommended.

Soldering conditions

Wave soldering: 260 °C, 10 s max.

C702F Smart Card Connectors with landing Card PCB Mount



Description	Contact position	Termination	Part No.
Landing card	GSM	Dip solder pin	C702 10M008 120 4
	ISO	Dip solder pin	C702 10M008 121 4
	AFNOR	Dip solder pin	C702 10M008 122 4
	ISO + AFNOR	Dip solder pin	C702 10M008 123 4

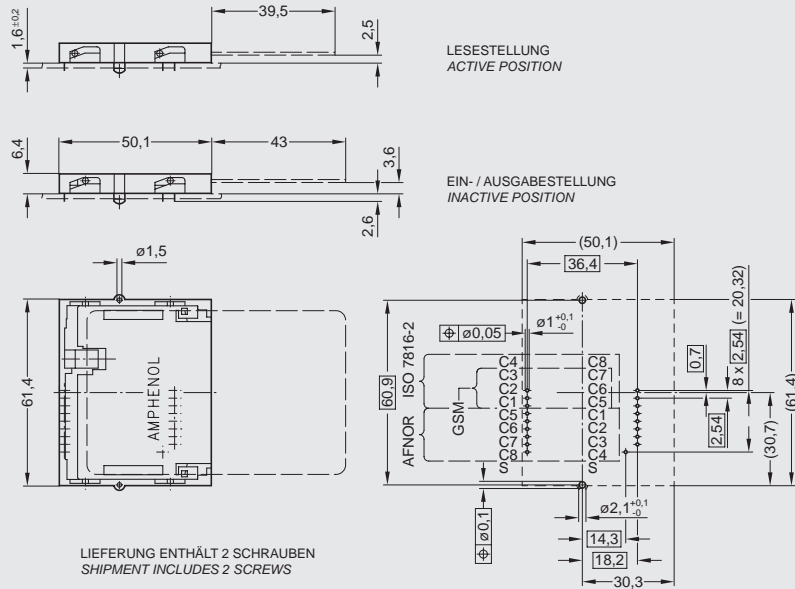

C702F Technical Data

Electrical Characteristics	Standard	Value
Contact resistance	IEC 60512-2, Test 2a	Data contacts $\leq 35 \text{ m}\Omega$, Switch contacts $\leq 70 \text{ m}\Omega$
Insulation resistance	IEC 60512-2, Test 3a	$\geq 10^9 \Omega$
High voltage resistance	IEC 60512-2, Test 4a	500 V _{AC} ; 1 min

Climatical Characteristics

Climatic category	IEC 60068-1	25 / 85 / 21
Operating temperature		- 25 °C ... + 85 °C
Storage temperature		- 40 °C ... + 85 °C

Mechanical Characteristics

Card insertion force	IEC 60512-7, Test 13b	$\leq 12 \text{ N}$
Card extraction force	IEC 60512-7, Test 13b	$\geq 2.5 \text{ N}$
Mechanical lifetime	IEC 60512-5, Test 9a (without corrosion stress)	300,000 mating cycles
Vibration	IEC 60512-4, Test 6d	f = 10 ... 60 Hz 0.7 mm DA f = 60 ... 500 Hz a = 5 g 2 h / axis
Shock, without disconnection	IEC 60512-4, Test 6c	$\leq 40 \text{ g}$; 6 ms; halfsine 3 shocks / direction in 3 axis
Shock, without destruction	IEC 60512-4, Test 6c	200 g; 6 ms; halfsine 2 shocks / direction in 3 axis
Contact force	–	20 ... 50 cN

Switch

Card presence switch		normally open
Switch sequence	The card presence switch is activated after the data contacts have mated with the card pads and before the card reaches its final position. This sequence will take place for the minimum sized pads (and larger) acc. to ISO 7816	
Chattering time	–	$\leq 5 \text{ ms}$

Smart Card Connectors

Hybrid Reader

Series C703A



Hybrid Reader

The manual Hybrid Reader accepts both ISO 7810 magstripe cards and ISO 7816 chip cards in the same slot. Push-pull card handling allows reading of the magnetic stripe on the way in or out, and reading/writing of the chip card when the card is fully inserted. Standard product features a dual head contact set (ISO & AFNOR) and track 2, 1 + 2 or 2 + 3 reading options available for the magnetic head. The head is suspended by a unique gimbaled (cardanian) system that assures accurate data transfer. The reader features a decoder circuit for each track and an 18 pin interface connector.

Usable Cards

Magstripe cards

ISO 7810, 7811, 7812; LOCO and HICO.
The magstripe will be read 100% during insertion and extraction of the card.

Chipcards

ISO 7816. Contact positions ISO, AFNOR and ISO & AFNOR can be read and written to.

Embossed cards acc. to ISO 7811, part 3 are accepted.



Assembly instructions:

The Smart Card Connector data contacts are connected to a pin header. F2F decoding of magstripe signal is done on a system board while data and clock signal are available separately. Card Detector 1 (CD1) detects the movement over the maghead and is low active until 50 ms after last clock signal of magtracks. Card Detector 2 (CD2) detects card active position. Data and clock signal of magtracks as well as CD1 and CD2 are TTL/CMOS compatible. This hybrid reader is intended for integration into electronic equipment and systems. When integrated, the EMC requirements of the respective equipment or system acc. to EMC guidelines 89/336 EWG shall be followed.

C703A Hybrid Reader



Description	Contact position	Magnetic track	Part No.
Magnetic head on bottom, with electronic and bezel	ISO	2	C703 10M008 101 5
	ISO	1 + 2	C703 10M008 103 5
	ISO	2 + 3	C703 10M008 104 5
Magnetic head on bottom, without electronic without bezel	ISO	1 + 2 + 3	C703 10M008 305 5
Bezel			C703 G05 040 E 5

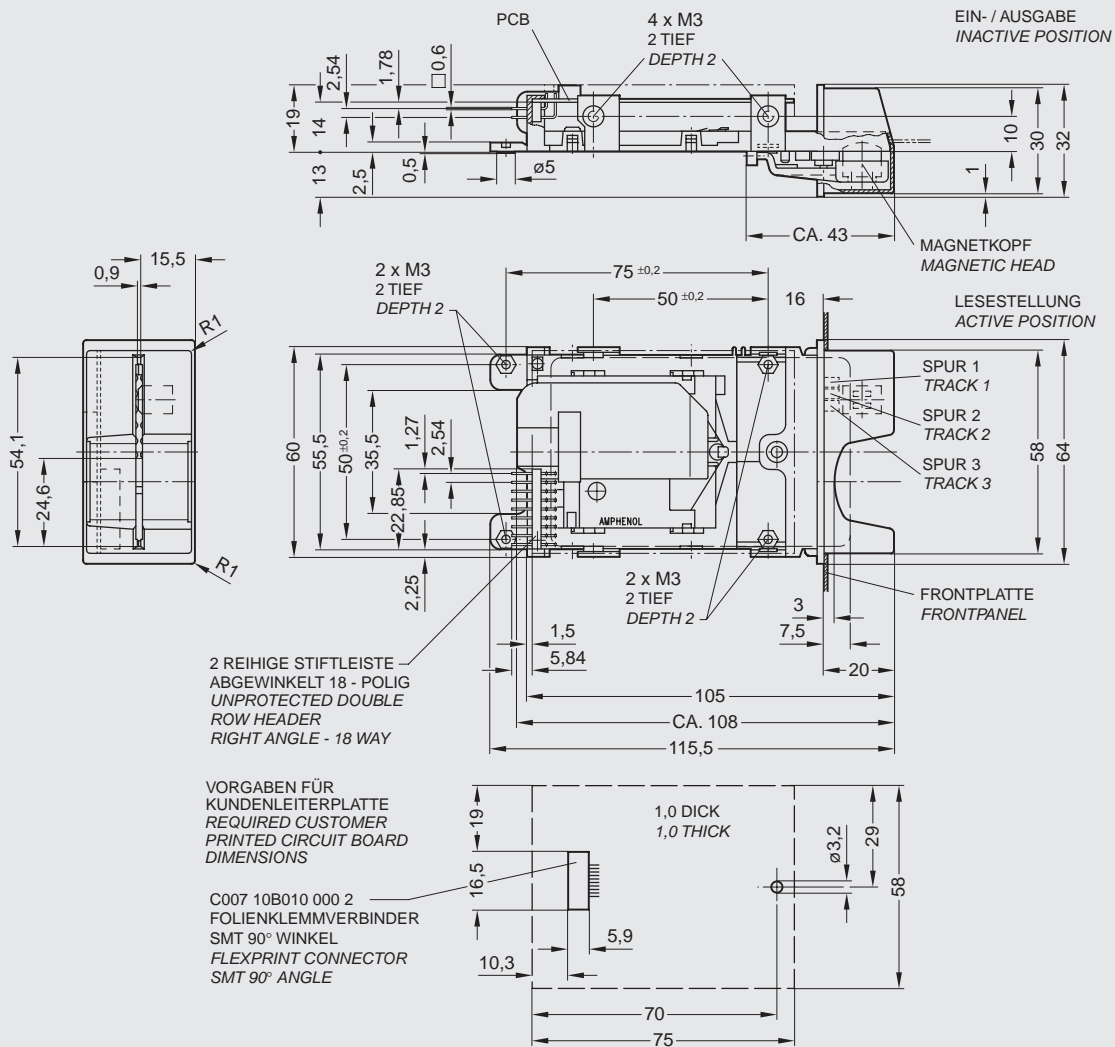

C703A Hybrid Reader

PIN-No.	Contact assignment	Remarks	PIN-No.	Contact assignment	Remarks
PIN 1	C1	Chipcard contacts (direct circuit)	PIN 10	Card Detector 2	Chip card can be activated (safety contact closed)
PIN 2	C2	Chipcard contacts (direct circuit)	PIN 11	+5 V	–
PIN 3	C3	Chipcard contacts (direct circuit)	PIN 12	–	–
PIN 4	C4	Chipcard contacts (direct circuit)	PIN 13	Data Track 1	–
PIN 5	C5 = Ground	Chipcard contacts (direct circuit)	PIN 14	Clock Track 1	–
PIN 6	C6	Chipcard contacts (direct circuit)	PIN 15	Data Track 2	–
PIN 7	C7	Chipcard contacts (direct circuit)	PIN 16	Clock Track 2	–
PIN 8	C8	Chipcard contacts (direct circuit)	PIN 17	Data Track 3	–
PIN 9	Card Detector 1	Magstripe is now being read	PIN 18	Clock Track 3	–

The 2 Track Magstripe readers have PIN 13 + 14 dedicated with Track 1 or 3. Track 2 is PIN 15 + 16. PINs 17 + 18 are not connected. All digital signals of the Magstripe readers are TTL low active.

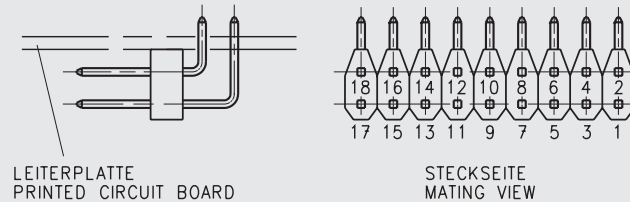

C703A Technical Data

Electrical Characteristics	Standard	Value
Contact resistance without cable or flexprint	IEC 60512-2, Test 2a	Data contacts $\leq 30 \text{ m}\Omega$ Switch contacts $\leq 40 \text{ m}\Omega$
Insulation resistance	IEC 60512-2, Test 3a	$\geq 10^9 \Omega$
High voltage resistance	IEC 60512-2, Test 4a	500 V _{ac} ; 1 min

Climatical Characteristics

Climatic category	IEC 60068-1	25 / 65 / 56
Operating temperature		- 25 °C ... + 65 °C
Storage temperature		- 40 °C ... + 85 °C

Mechanical Characteristics

Card insertion force	IEC 60512-7, Test 13b	$\leq 8 \text{ N}$
Card extraction force	IEC 60512-7, Test 13b	$\geq 3 \text{ N}$
Mechanical lifetime	IEC 60512-5, Test 9a (no corrosion stress)	300,000 mating cycles
Contact force		20 ... 50 cN

Switch

Card presence switch		Logical 0 with inserted card
Switch sequence	The card presence switch is activated after the data contacts have mated with the contact field and before the card reaches its final position.	

Magstripe reader

Resistance of magnetic head		290 $\Omega \pm 20 \%$ (at f = 100 Hz)
Inductance of magnetic head		110 mH $\pm 25 \%$ (at f = 1 KHz)

Smart Card Connectors with Disk Drive Slot

Series C705A



Disk Drive Slot
3 1/2"

Page 45



Disk Drive Slot
5 1/4"

Page 45

Disk Drive Slot Smart Card Connectors

for spare disk drive slots in PCs are a combination of:

- a Smart Card Connector (C702A) with Push-Pull card handling mounted on a 3.5 inch or 5.25 inch disk drive frame (tan color: RAL 7032) with a bicolor LED (red/green)
- 14 way flat cable with a socket connector according to IEC 60603-13; two cable lengths are available for desktop and tower housings
- mounting screws



Assembly instructions:

Please make sure that interface cables are unrestricted and free to move after assembly.

Versions without LED or with other Smart Card Connectors are available upon request.

C705A Technical Data

Electrical Characteristics	see page 14
Climatical Characteristics	see page 14
Mechanical Characteristics	see page 14

C705A Smart Card Connectors with Disk Drive Slot



Description	Contact position	Type	Part No.
Disk Drive Slot 3 1/2"	ISO	Tower	C705 10M008 005 5
Disk Drive Slot 3 1/2"	ISO	Desktop	C705 10M008 019 5

Type	Dimension A	Dimension B
Tower	972 ±4	911 ±4
Desktop	484 ±4	423 ±4

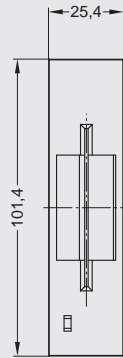

KATHODE / CATHODE -12
FREI / NOT CONNECTED

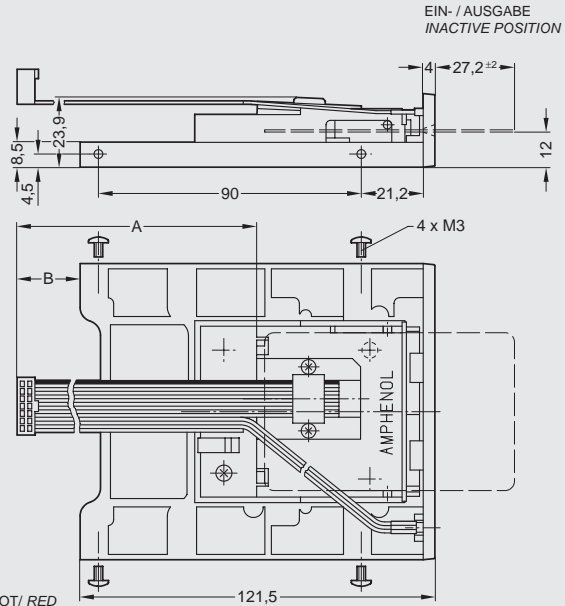
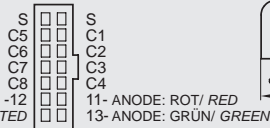

C705A Smart Card Connectors with Disk Drive Slot



Description	Contact position	Type	Part No.
Disk Drive Slot 5 1/4"	ISO	Tower	C705 10M008 006 5
Disk Drive Slot 5 1/4"	ISO	Desktop	C705 10M008 020 5

Type	Dim.A	Dim.B	Dim.C
Tower	972 ±4	911 ±4	900 ±4
Desktop	484 ±4	423 ±4	412 ±4

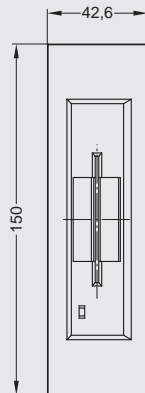

KATHODE / CATHODE -12
FREI / NOT CONNECTED

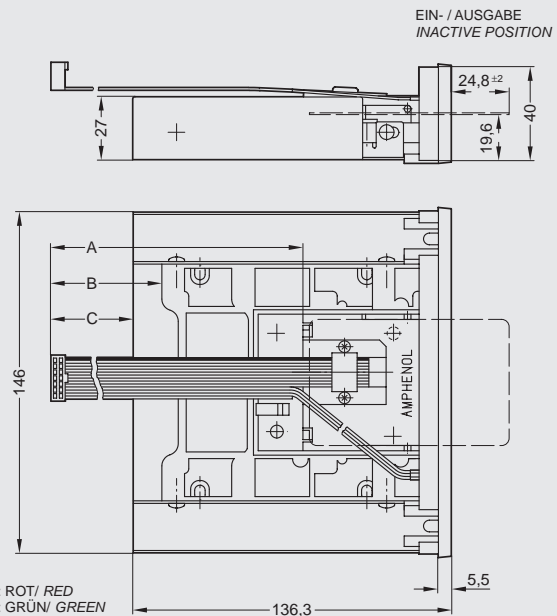
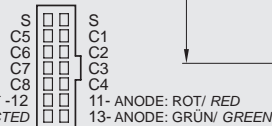

Smart Card Connectors

SIMLOCK®

Series C707A

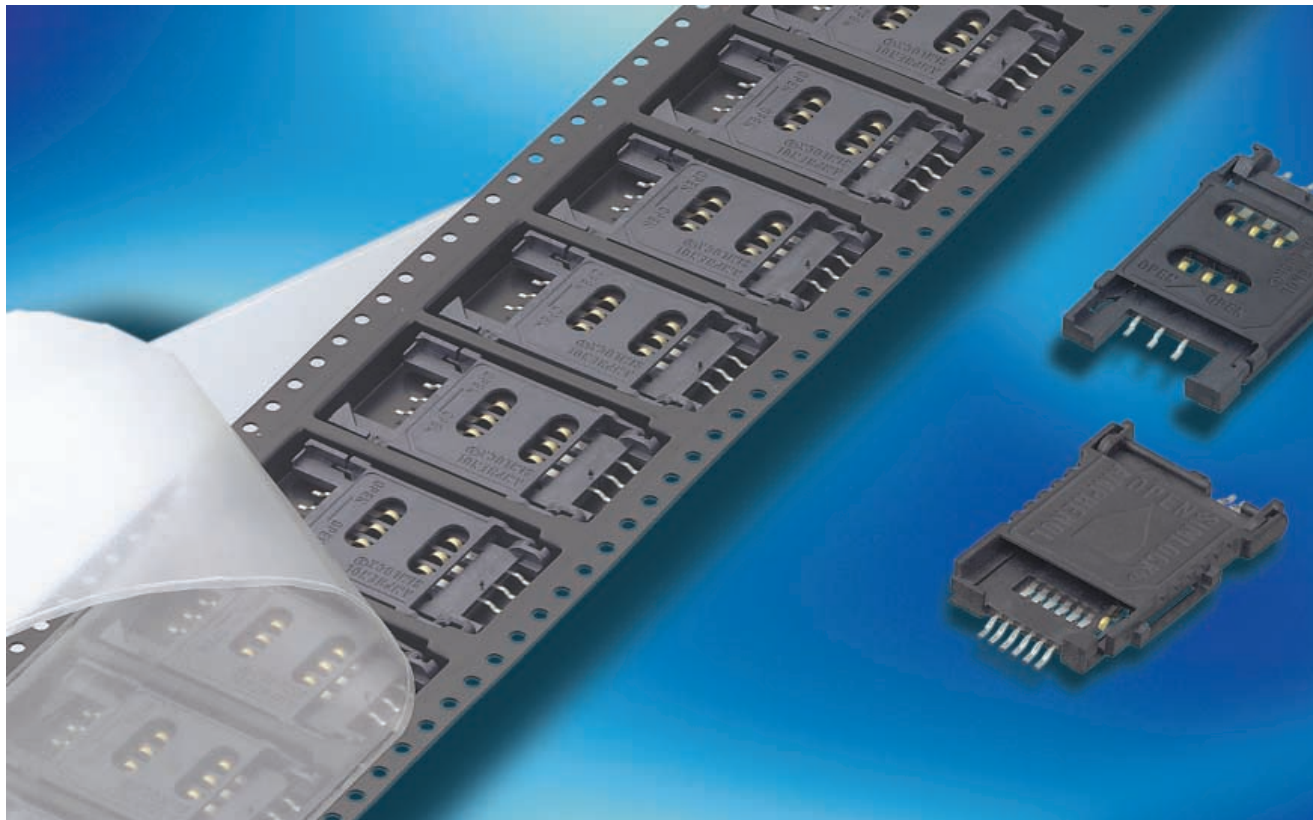

6 contacts
Low Profile
with card
presence switch

Page 47



6 contacts
Low Profile

Page 47



with or without
locking detector
4 positioning pins

Page 48



with or without
locking detector
2 positioning pins

Page 48

SIMLOCK®

designed for SIM/SAM card applications.

Design features

- size: same footprint as SIM card
- reliable function in locked state during mobile use
- designer does not have to be concerned with housing tolerances and card guiding due to self contained system
- polarization notch does not allow incorrect card positioning
- SIMLOCK® with locking detector (or card presence switch) available
- suitable for automatic assembly processes (Pick & Place, Tape & Reel and Reflow)
- contact carrier and lid can be delivered separately upon request
- custom geometries and layout designs possible

For your special requirements please contact Amphenol-Tuchel Electronics GmbH (see back page).



Assembly instructions:

Versions with locking detector lid must be unlocked during reflow process or lid can be packaged separately and snapped in place after reflow.

Soldering conditions:

Infrared reflow: 245°C; 10 s max.

C707A Smart Card Connectors SIMLOCK®



Description	Packaging	Part No.
6 contacts (3+3), low profile, with card presence switch, without positioning pins	800 pieces on "Tape & Reel" 20 mm pitch	C707 10M006 522 2
2 different positioning pins ¹⁾	800 pieces on "Tape & Reel" 20 mm pitch	C707 10M006 523 2

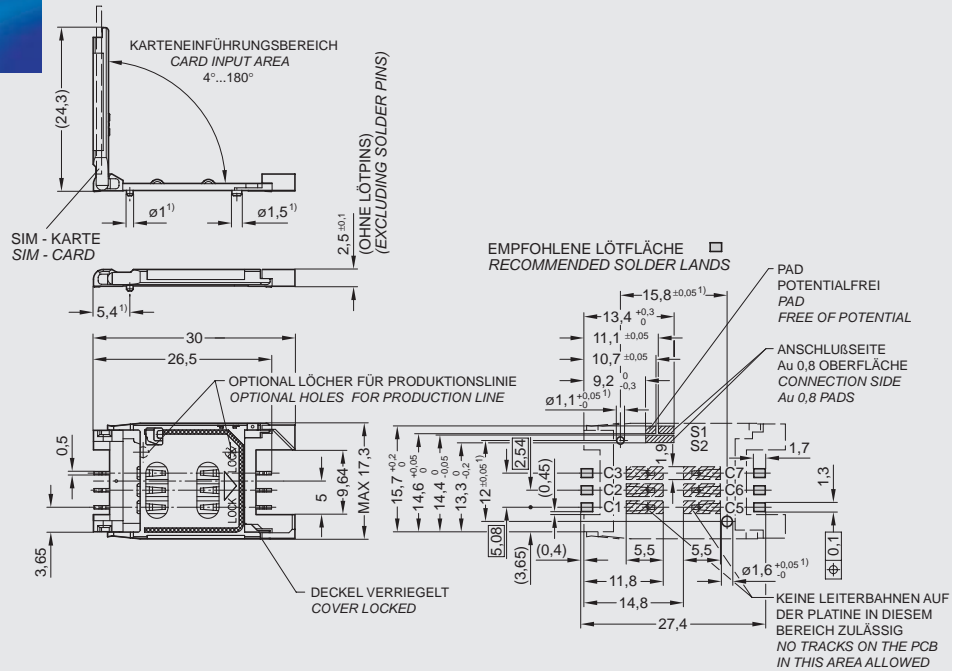

C707A Smart Card Connectors SIMLOCK®



Description	Packaging	Part No.
6 contacts (3+3), low profile, 2 different positioning pins ¹⁾	800 pieces on "Tape & Reel" 20 mm pitch	C707 10M006 049 2
6 contacts (3+3), low profile, without positioning pins ¹⁾ , index dimensions unnecessary	800 pieces on "Tape & Reel" 20 mm pitch	C707 10M006 500 2

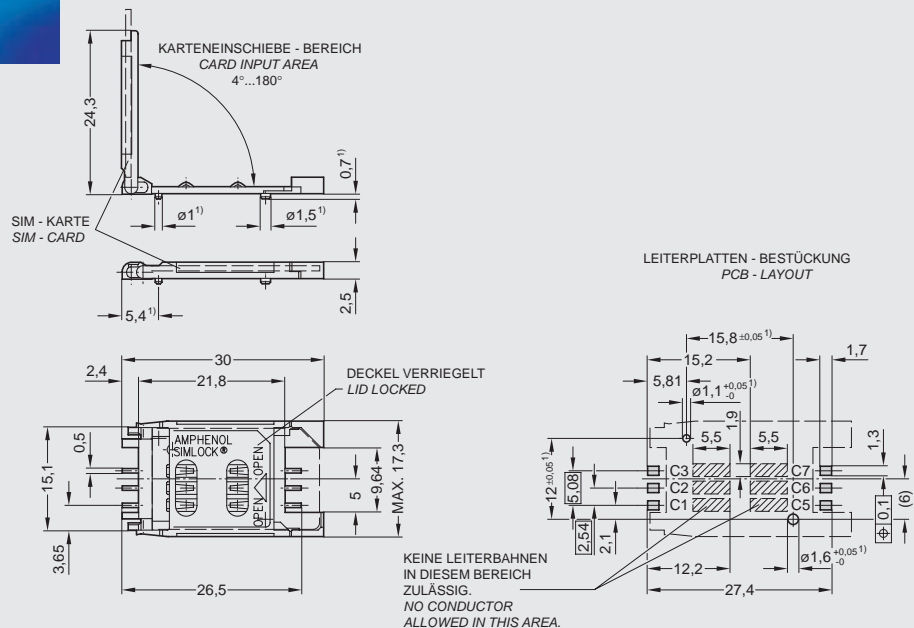

C707A Smart Card Connectors SIMLOCK®



Description	Packaging	Part No.
with locking detector, 4 positioning pins	140 pieces per styrofoam tray	C707 10M006 000 2
with locking detector, 4 positioning pins, without lid	600 pieces on "Tape & Reel" 24 mm pitch	C707 10M006 026 2
without locking detector, 4 positioning pins	140 pieces per styrofoam tray	C707 10M006 001 2
Lid for SIMLOCK® with locking detector	600 pieces in bag	C707 10M006 027 2

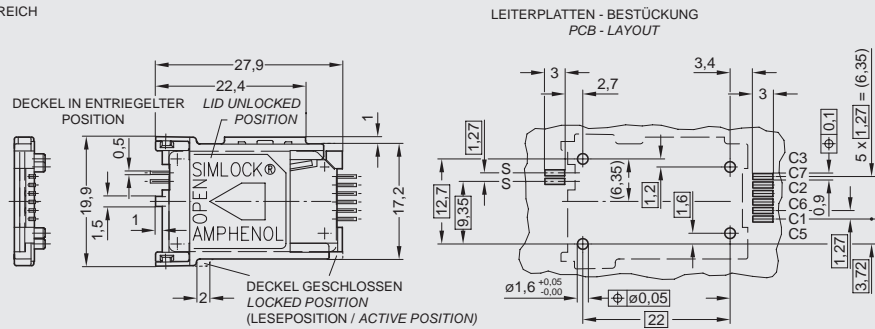
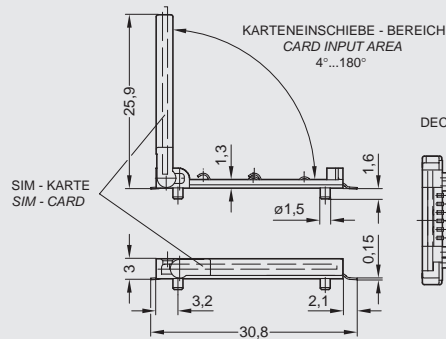

C707A Smart Card Connectors SIMLOCK®



Description	Packaging	Part No.
with locking detector, 2 positioning pins	140 pieces per styrofoam tray	C707 10M006 007 2
with locking detector, 2 positioning pins, without lid	600 pieces on "Tape & Reel" 20 mm pitch	C707 10M006 503 2
without locking detector, 2 positioning pins	600 pieces on "Tape & Reel" 24 mm pitch	C707 10M006 021 2
without locking detector, 2 positioning pins	140 pieces per styrofoam tray	C707 10M006 031 2
Lid for SIMLOCK® with locking detector	600 pieces in bag	C707 10M006 027 2

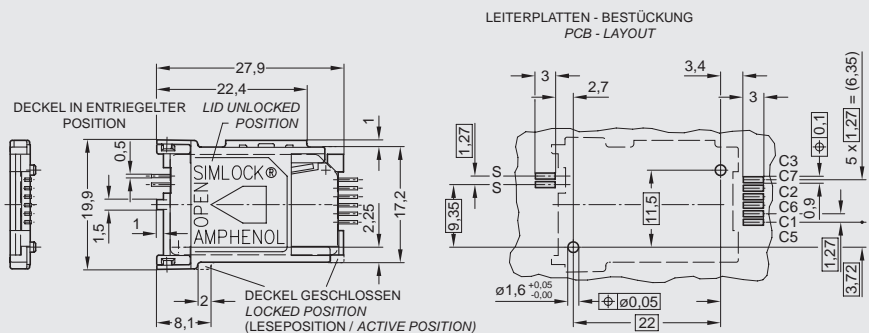
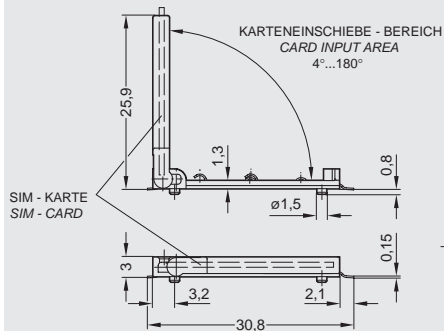

C707A Technical Data

Electrical Characteristics	Standard	Value
Contact resistance	IEC 60512-2, Test 2a	Data contacts $\leq 30 \text{ m}\Omega$ Switch contacts $\leq 60 \text{ m}\Omega$
Insulation resistance	IEC 60512-2, Test 3a	$\geq 10^9 \Omega$
High voltage resistance	IEC 60512-2, Test 4a	500 V _{AC} ; 1 min

Climatical Characteristics

Climatic category	IEC 60068-1	40 / 85 / 21
Operating temperature		- 40 °C ... + 85 °C
Storage temperature		- 40 °C ... + 85 °C

Mechanical Characteristics

Lid locking force		4 ... 8 N
Mechanical lifetime	IEC 60512-5, Test 9a	5,000 operations
Vibration	IEC 60512-4, Test 6d	f = 10 ... 60 Hz 0.8 mm DA f = 60 ... 500 Hz a = 6 g 2 h / axis
Shock, without disconnection	IEC 60512-4, Test 6c	$\leq 100 \text{ g}$; 6 ms; halfsine 100 shocks / direction in 3 axis
Shock, without destruction	IEC 60512-4, Test 6c	500 g; 1 ms; halfsine, 2 shocks / direction in 3 axis
Contact force		20 ... 50 cN

Switch

Security switch		closed, when lid locked
Chattering time		$\leq 5 \text{ ms}$

C707A Smart Card Connectors SIMLOCK®

"Tape & Reel" packaging for SIMLOCK®

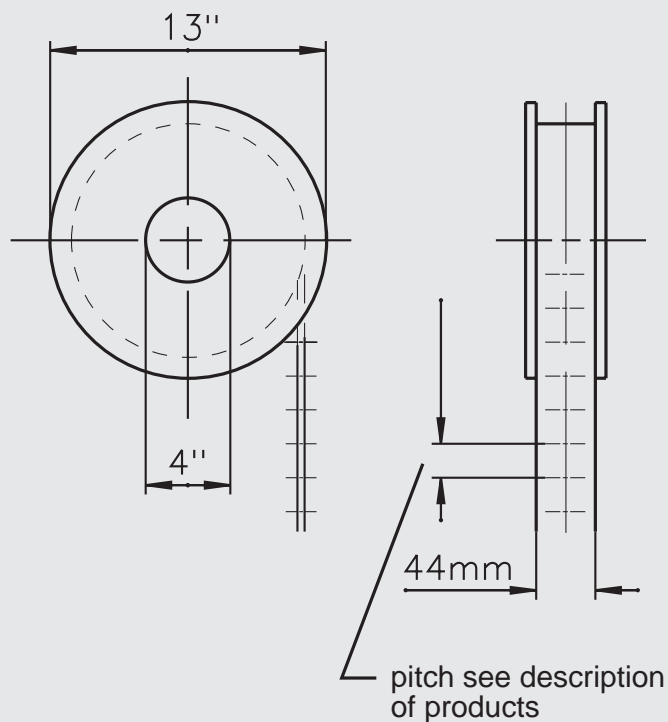

Smart Card Connectors

SIMBLOCK®

Series C707B

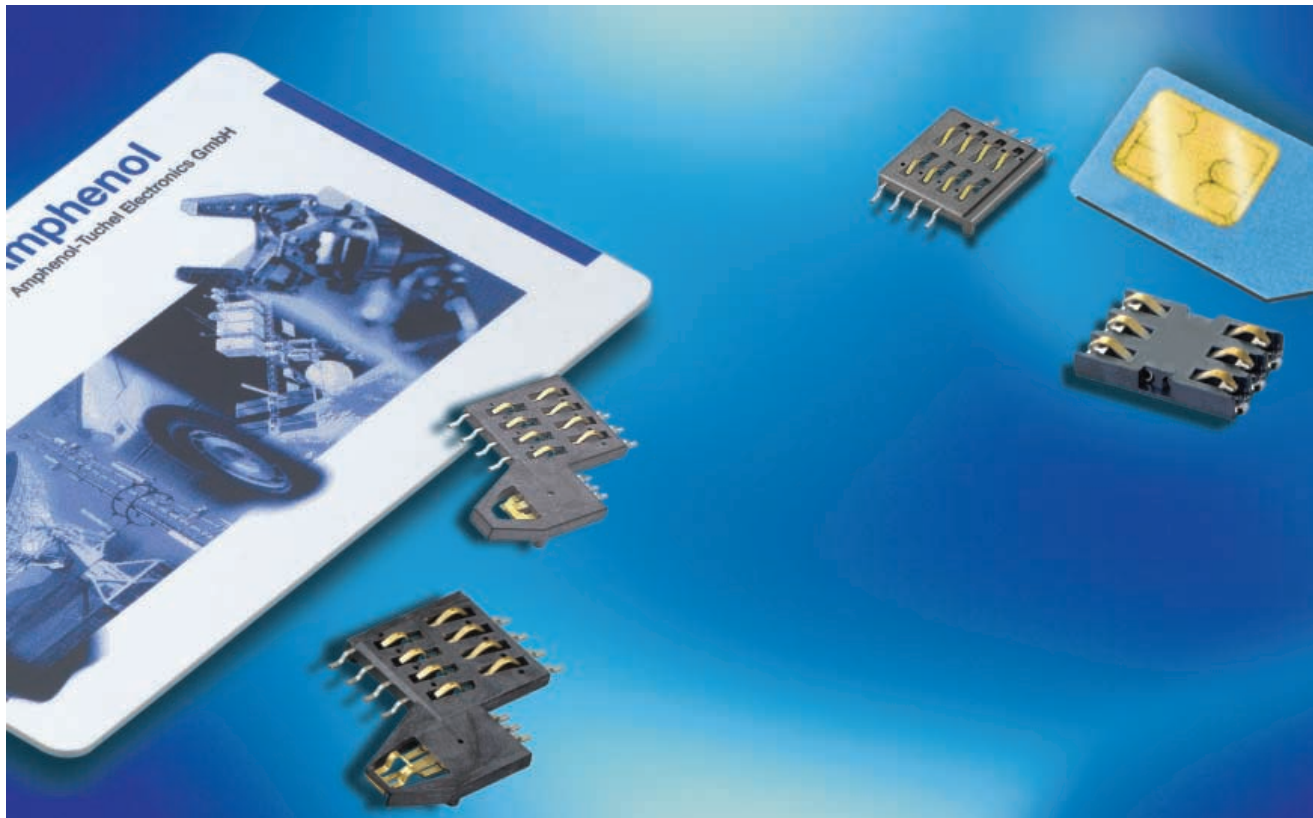

without switch Page 51
6 contacts



U-form Page 51
6 contacts



without switch Page 52



with switch Page 52
(normally closed)



with switch Page 53
(normally open)



Wingblock Page 53
with card
guide and
card stop

SIMBLOCK®

Due to miniature size, SIMBLOCK® is suitable for mobile applications from handsets to e-purses.

Design features

- contacts chip cards according to ISO 7816 and Plug-In SIM-Cards
- suitable for automatic assembly processes (packaging designed for Pick & Place process and Reflow)
- low height (2 mm standard)
- high co-planarity accuracy
- SMT-Version with 6 contacts especially designed for GSM 11.11 interfaces
- solderfree versions with float contacts for PCB mount
- versions with spoon contacts available for any operation direction of the chip card



Assembly instructions:

For reliable function make sure that card is positioned and supported as shown on drawing.

Soldering conditions:

Infrared reflow: 245 °C; 10 s max.
230 °C SIMBLOCK®
with switch

C707B Smart Card Connectors SIMBLOCK®

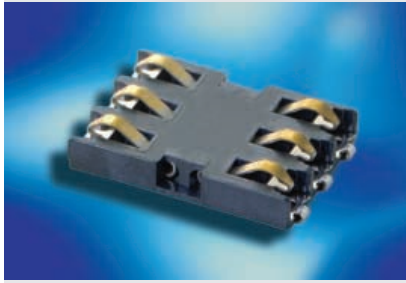

Description	usable chipcards			Part No.
	ISO 7816, contact position			
	ISO	AFNOR	SIM-Cards	
without switch, 6 contacts (3+3)	•	-	•	C707 10M006 094 2

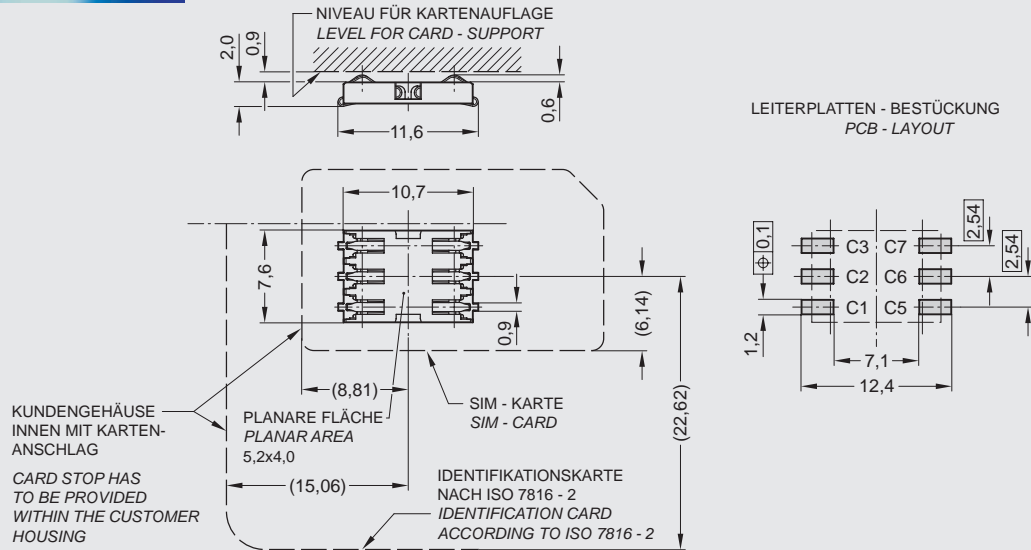

C707B Smart Card Connectors SIMBLOCK®



Description	usable chipcards			Part No.
	ISO 7816, contact position			
	ISO	AFNOR	SIM-Cards	
U-form, without switch, 6 spoon contacts (3+3) with float contacts for solderfree PCB mount	•	-	•	C707 10M006 092 2

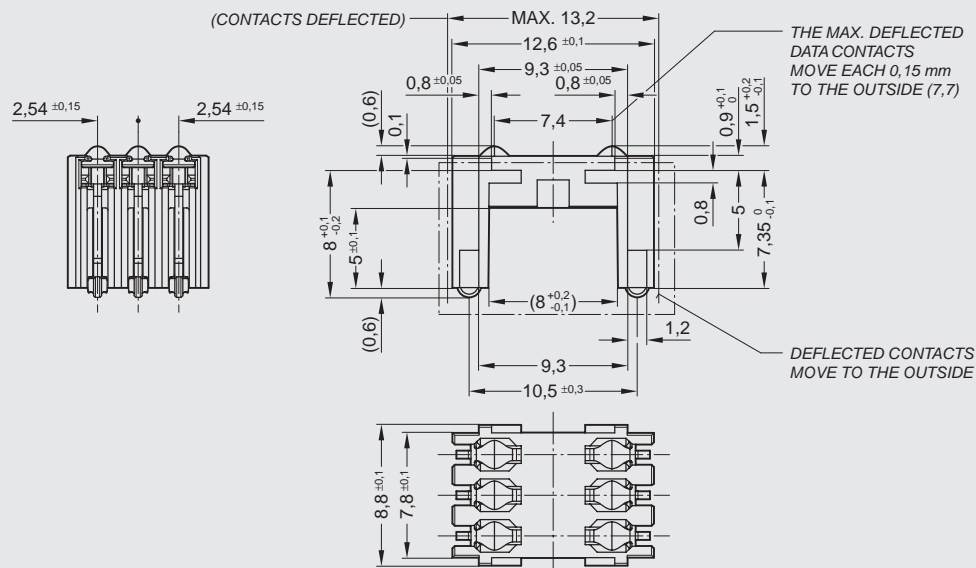

C707B Smart Card Connectors SIMBLOCK®



Description	usable chipcards ISO 7816, contact position			Part No.
	ISO	AFNOR	SIM-Cards	
without switch	•	•	•	C707 10M006 052 2

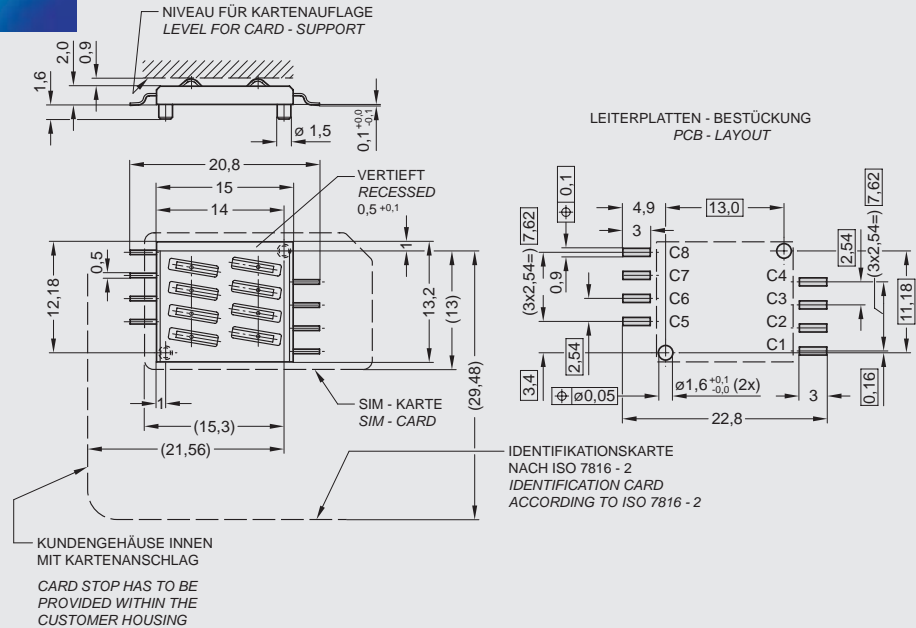

C707B Smart Card Connectors SIMBLOCK®



Description	usable chipcards ISO 7816, contact position			Part No.
	ISO	AFNOR	SIM-Cards	
with switch (normally closed)	•	-	-	C707 10M006 053 2

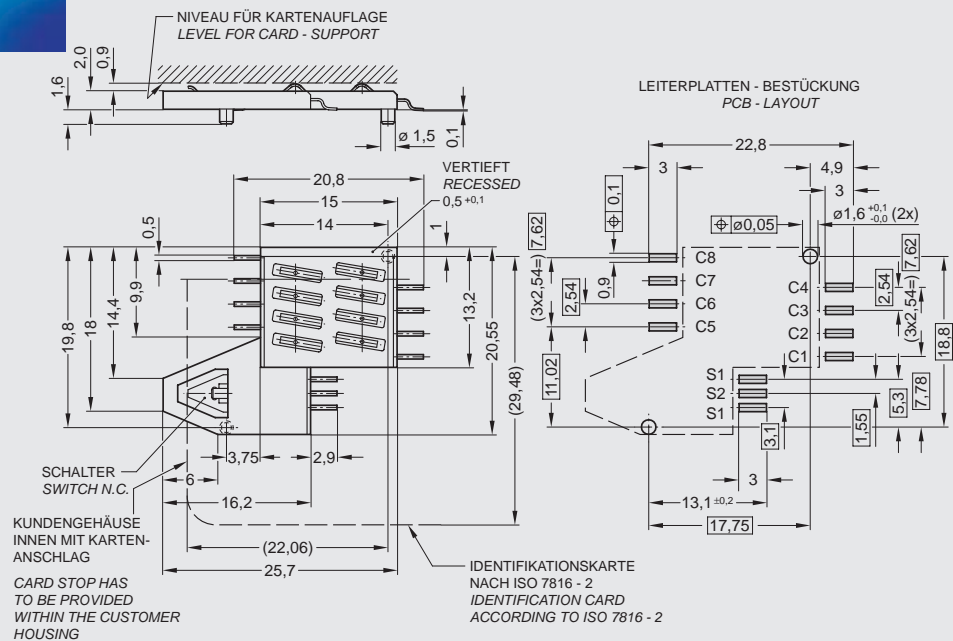

C707B Smart Card Connectors SIMBLOCK®



Description	usable chipcards			Part No.
	ISO	AFNOR	SIM-Cards	
with switch (normally open)	•	-	-	C707 10M006 065 2

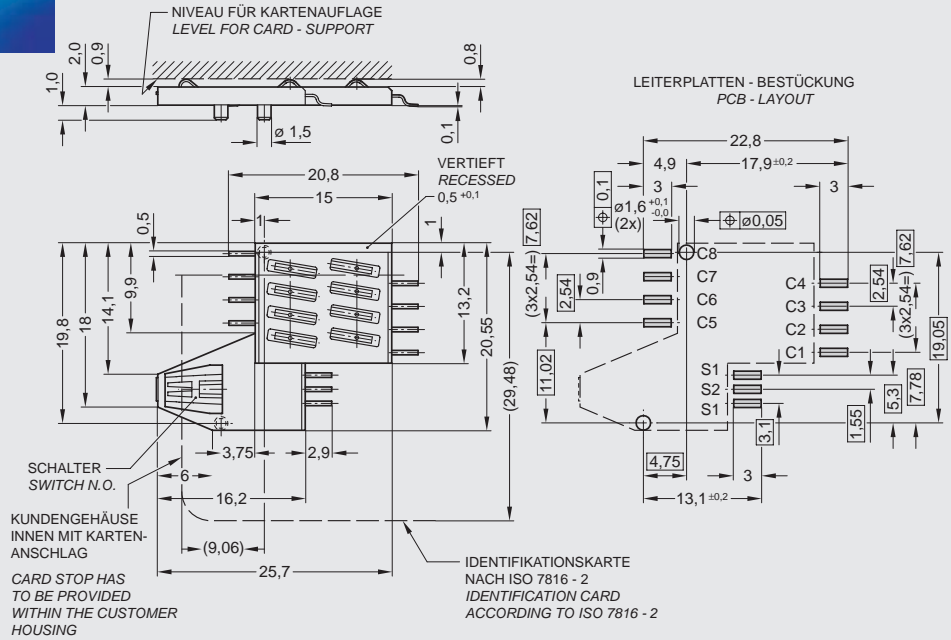

C707B Smart Card Connectors SIMBLOCK®



Description	usable chipcards			Part No.
	ISO	AFNOR	SIM-Cards	
WINGBLOCK with card guide and card stop	-	-	•	C707 10M006 097 2

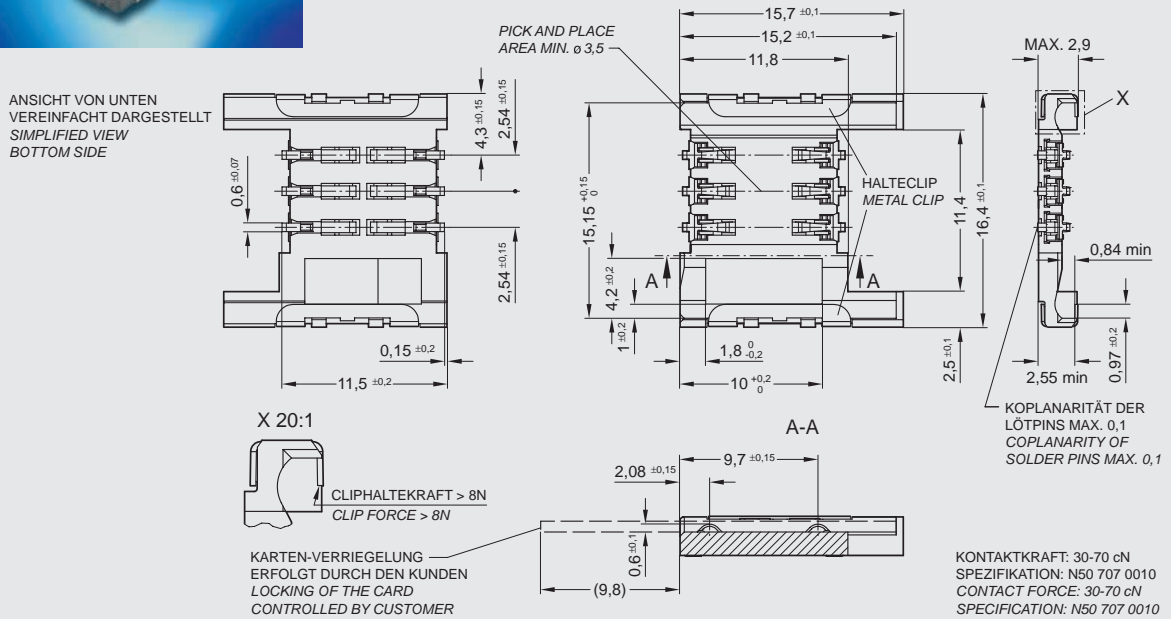

C707B Technical Data

Electrical Characteristics	Standard	Value
Contact resistance	IEC 60512-2, Test 2a	Data contacts $\leq 30 \text{ m}\Omega$ Data contacts U-form: $\leq 100 \text{ m}\Omega$ Switch contacts $\leq 50 \text{ m}\Omega$
Insulation resistance	IEC 60512-2, Test 3a	$\geq 10^9 \Omega$
High voltage resistance	IEC 60512-2, Test 4a	500 V _{Ac} ; 1 min

Climatical Characteristics

Climatic category	IEC 60068-1	40 / 85 / 21
Operating temperature		- 40 °C ... + 85 °C
Storage temperature		- 40 °C ... + 85 °C

Mechanical Characteristics

Mechanical lifetime	IEC 60512-5, Test 9a	10,000 mating cycles
Vibration	IEC 60512-4, Test 6d	f = 10 ... 60 Hz 0.7 mm DA f = 60 ... 500 Hz a = 5 g 2 h / axis
Shock, without disconnection	IEC 60512-4, Test 6c	$\leq 40 \text{ g}$; 6 ms; halfsine 10 shocks / direction in 3 axis
Shock, without destruction	IEC 60512-4, Test 6c	500 g; 1 ms; halfsine 2 shocks / direction in 3 axis
Contact force		20 ... 50 cN

Switch

Card presence switch		normally open/normally closed
Chattering time		$\leq 5 \text{ ms}$

MultiMediaCard Connector

Series C709A

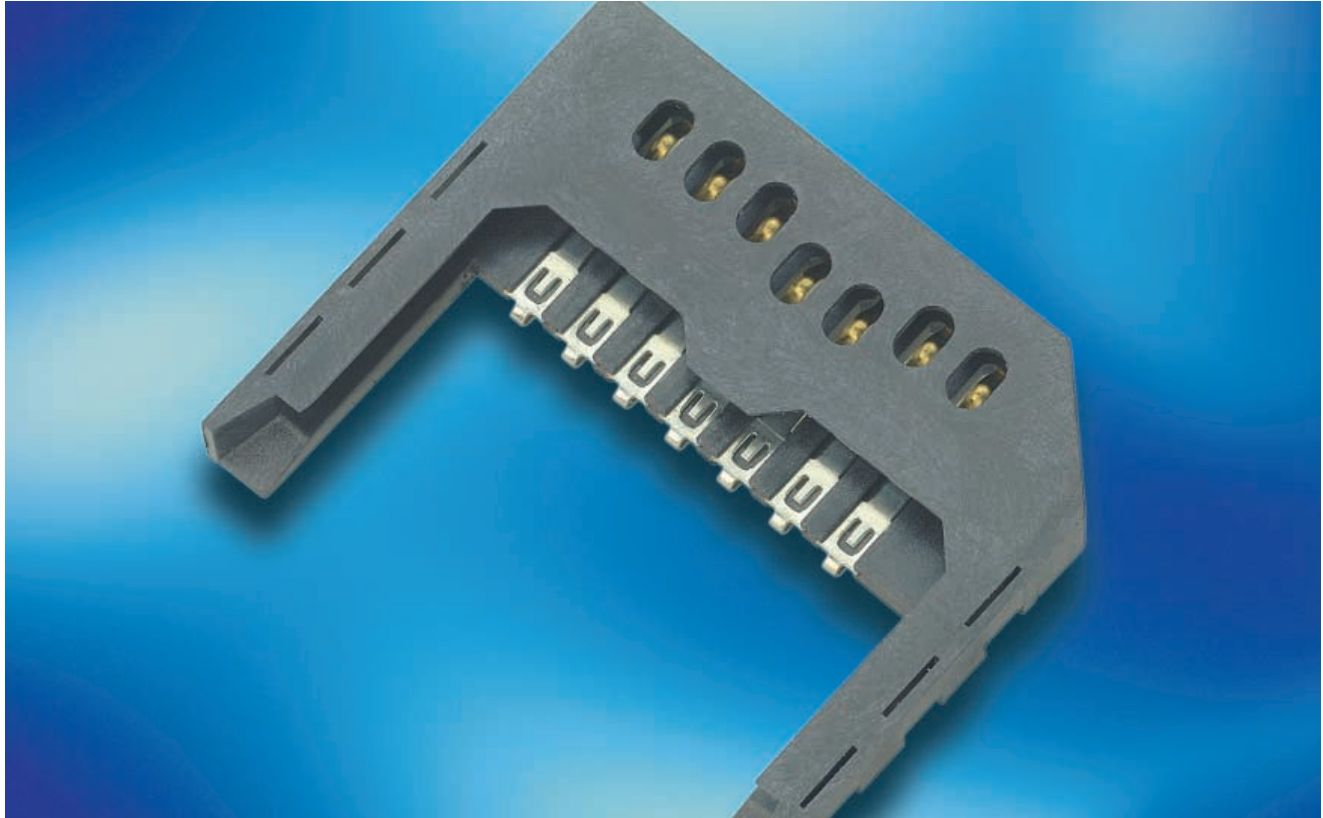

The MultiMediaCard Connector (MMC) and the Secure Digital Memory Card Connector* (SD Card) are designed for attaching, fixing and electrically interconnecting the card to the system board. Most suitable applications are:

- Telecommunication
- Audio
- Video
- PC
- Consoles (video games etc.)
- Navigation
- Automotive
- Industry
- MP3 player

Design features

- minimized co-planarity tolerances due to advanced terminal design
- on board space saving due to termination geometry
- holes for mechanical and electrical contact tests
- customized fastening
- acc. to MMCA specification



For realization of your custom requirements please use the Smart Card Connector competence and experience of our design engineers.

*) without picture

C709A MultiMediaCard Connector

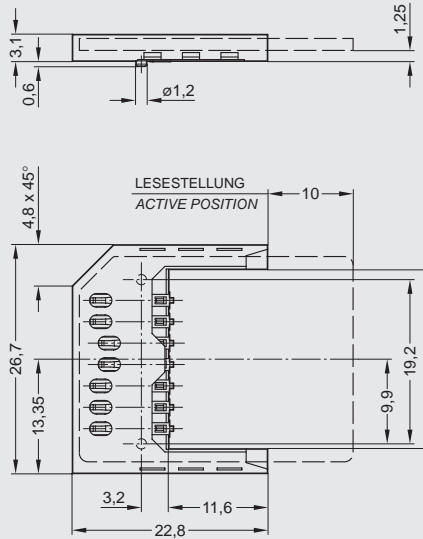

LEITERPLATTEN - BESTÜCKUNG
PCB - LAYOUT

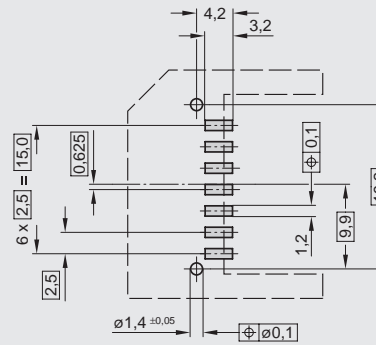

Description

Part No.

MultiMediaCard Connector C709 10A007 100 1

Other designs and Secure Digital Card Connectors upon request.

C709A Technical Data

Electrical Characteristics

Electrical Characteristics	Standard	Value
Contact resistance	IEC 60512-2, Test 2a	≤ 30 mΩ
Insulation resistance	IEC 60512-2, Test 3a	≥ 10 ⁹ Ω
High voltage resistance	IEC 60512-2, Test 4a	500 V

Climatical Characteristics

Climatical category	IEC 60068-1	25 / 85 / 21
Operating temperature		- 25 °C ... + 85 °C
Storage temperature		- 40 °C ... + 90 °C

Mechanical Characteristics

Card insertion force	IEC 60512-7, Test 13b	max. 40 N
Card extraction force	IEC 60512-7, Test 13b	> 1 N
Mechanical lifetime		10,000 mating cycles
Random vibration	IEC 60512-6, Test 6e	f = 10 Hz ... 2 kHz a = 6 g RMS 15 min / axis
Shock, without disconnection	IEC 60512-4, Test 6c	40 g; 11 ms 100 shocks / direction in 3 axis
Shock, without destruction	IEC 60512-4, Test 6c	500 g; 1 ms 3 shocks / direction in 3 axis
Contact force		20 ... 60 cN
No. of contacts		7
Contacts	Wiping contacts with 2 pre-mating contacts	
Termination	SMT	
Mounting style	upon customer request	

Keyword Index

Keyword	Page
Adaptor	17/21
AFNOR	6
Automatic assembly process	46/50
Bezel	10/13/15/16/17/20
Card handling systems	2/4/7/10/31
Card lock	17/18
Card locking detector	13/14
Card presence switch	17/19/21/22/23 46/47/49/54
Chip card sizes	6
Company information	4
Contact methods	8
Contents	3
Debris slot	22/23
Disk drive slot	44/45
EMV	6
Flexprint connector	24/28/29
Hybrid reader	41/42/43
ISO	6
Landing card	8/39
Low Profile PUSHMATIC	22/23
Magstripe cards	41
Manufacturing reference	5
Mounting plate	10/16
MultiMediaCard	6/55/56
PCB mount	31/32/33/34/35 37/38/39/40
Push-Lift SSC	25/27
PUSHMATIC®	7/12/13/14/15/16
PUSHMATIC® II	10/17/18/20/21
Push-Only SCC	7/11/14/15
Push-Pull SCC	7/11/14/15/25
Push-Push SCC	7/10/12
Quality certifications	4
Quality reference	4
Secure Digital Memory Card	6/55
Security information	2
Shutter	13/14
SIMBLOCK®	9/50/51/52/53
SIMLOCK®	9/46/47/48/49

Keyword	Page
Smart Card Connector function	6
Snap-in hooks	31/32/33/34 36/37/38
Standard style	10/11/12/13 15/16/44
Superflat style	25/26/27/28
Wiping contacts	8/31/32/33/34 35/36/37/38/56

Part No. - Index

Part No.	Page
C007 10B008 000 1	29
C007 10B008 000 2	29
C007 10B008 100 1	29
C007 10B008 100 2	29
C007 10B010 000 1	29
C007 10B010 000 2	29
C007 10B010 100 1	29
C007 10B010 100 2	29
C702 10M008 001 4	26
C702 10M008 015 2	12
C702 10M008 018 2	11
C702 10M008 023 4	26
C702 10M008 040 4	27
C702 10M008 060 4	27
C702 10M008 061 4	28
C702 10M008 063 4	27
C702 10M008 065 4	26
C702 10M008 066 4	28
C702 10M008 120 4	40
C702 10M008 121 4	40
C702 10M008 122 4	40
C702 10M008 123 4	40
C702 10M008 201 4	36
C702 10M008 202 4	36
C702 10M008 203 4	36
C702 10M008 205 4	36
C702 10M008 206 4	36
C702 10M008 207 4	36
C702 10M008 224 4	37
C702 10M008 226 4	38
C702 10M008 230 4	37
C702 10M008 235 4	38
C702 10M008 244 4	37
C702 10M008 255 4	32
C702 10M008 271 4	33
C702 10M008 272 4	32
C702 10M008 278 4	34
C702 10M008 279 4	34
C702 10M008 283 4	33
C702 10M008 286 4	34
C702 10M008 290 4	35
C702 10M008 294 4	35
C702 10M008 295 4	34
C702 10M008 514 2	11
C702 10M008 521 2	11
C702 10M008 522 2	11
C702 10M008 523 2	11
C702 10M008 700 2	12
C702 10M008 701 2	12
C702 10M008 702 2	12
C702 10M008 703 2	12
C702 10M008 704 2	12
C702 10M008 705 2	12
C702 10M008 706 2	12
C702 10M008 707 2	12

Part No.	Page
C702 10M008 708 2	12
C702 10M008 716 2	13
C702 10M008 727 2	13
C702 10M008 732 2	13
C702 10M008 901 4	23
C702 10M008 902 4	23
C702 10M008 903 4	23
C702 10M008 904 2	18
C702 10M008 905 2	18
C702 10M008 906 2	18
C702 10M008 907 2	18
C702 10M008 909 2	18
C702 10M008 910 2	18
C702 20M008 700 2	13
C702 20M008 701 2	13
C702 20M008 702 2	13
C702 G46 000 G2	20
C702 G46 100 G2	20
C702 G51 012 E2	20
C702 N11 141 E2	16
C702 N13 030 E2	15
C702 N13 031 E2	15
C702 N14 030 E2	16
C702 N15 100 G2	15
C702 N25 040 E2	21
C703 10M008 101 5	42
C703 10M008 103 5	42
C703 10M008 104 5	42
C703 10M008 305 5	42
C703 G05 040 E 5	42
C705 10M008 005 5	45
C705 10M008 006 5	45
C705 10M008 019 5	45
C705 10M008 020 5	45
C707 10M006 000 2	48
C707 10M006 001 2	48
C707 10M006 007 2	48
C707 10M006 021 2	48
C707 10M006 026 2	48
C707 10M006 027 2	48
C707 10M006 031 2	48
C707 10M006 049 2	47
C707 10M006 052 2	52
C707 10M006 053 2	52
C707 10M006 065 2	53
C707 10M006 092 2	51
C707 10M006 094 2	51
C707 10M006 097 2	53
C707 10M006 500 2	47
C707 10M006 503 2	48
C707 10M006 522 2	47
C707 10M006 523 2	47
C709 10A007 100 1	56
N06 702 0001	16
N06 702 0002	16

International

Argentina

Amphenol Argentina
Av. Callao 930
2nd Floor Office B "Plaza"
C1023 AAP Buenos Aires
Phone +54 / 11 / 48 15 35 79
Fax +54 / 11 / 48 14 57 79

Australia

Amphenol Australia Ltd.
2 Fiveways Blvd
Keysborough
Victoria 3173
Phone +61 / 3 / 8796 / 88 88
Fax +61 / 3 / 8796 / 88 01

Austria

Amphenol Ges. m. b. H.
Johnstraße 42, Top 3A
1150 Wien
Phone +43 / 1 / 9 85 15 11
Fax +43 / 1 / 9 82 61 01

Brazil

Amphenol do Brasil Ltda.
Ave. Roque Petroni Jr. 999, 13th Floor
CEP 04707-910 Sao Paulo-SP
Phone +55 / 11 / 5185.2881
Fax +55 / 11 / 5185.2812

France

Amphenol Socapex France
21 Chemin du Défois
B.P. 349
39105 Dôle Cedex
Phone +33 / 3 / 8482 9400
Fax +33 / 3 / 8482 9411

Germany

Amphenol-Tuchel Electronics GmbH
August-Häusser-Str. 10
74080 Heilbronn
Phone +49 / 71 31 / 929-0
Fax +49 / 71 31 / 929-486

Great Britain

Amphenol-Tuchel Electronics
39 Rowlands Castle Road
Horndean
Waterlooville,
Hants, PO8 0DF
Phone: +44 / 2392 / 571791
Fax +44 / 2392 / 571791

Hong Kong

Amphenol East Asia Limited
Units 2201-02, Railway Plaza
39 Chatham Road South
Tsimshatsui, Kowloon
Phone +852 / 2699 / 2663
Fax +852 / 2688 / 0974

India

Amphetronix Limited
Plot No. 105 Bhosari Industrial Area
Pune - 411 026
Phone +91 / 20 / 7121418
Fax +91 / 20 / 7120581

Italy

Amphenol Italia S.p.A.
Via Barbaiana n. 5
I-20020 Lainate (MI)
Phone +39 / 2 / 93 254.1
Fax +39 / 2 / 93 254.445

Japan

Amphenol Japan, K.K.
2-3-27, Kudan Minami
Chiyoda-Ku
Tokyo 102
Phone +81 / 3 / 32 63 / 56 11
Fax +81 / 3 / 52 76 / 70 59

Korea

Amphenol DaeShin Limited
#802 Joong-Dong 1131-5
Wonmi-Ku
Bucheon-City
Kyunggi-Do
Korea 420-020
Phone +82 / 2 / 785 / 15 88
Fax +82 / 2 / 589 / 15 14

Mexico

Amphenol Mexico
Presidente Masaryk 61, Piso 2
C.P. 11560 Mexico D.F.
Phone +52 / 5 / 203.2178
Fax +52 / 5 / 531.9659

South Africa

Amphenol International Ltd
Chislehurst
30 Impala Road
Chislehurst
Sandton, 2146
Phone +27 / 11 / 783 95 17
Fax +27 / 11 / 783 95 19

Spain

Amphenol Ibérica
C/Comunidad de Madrid, 35-bis
oficina Nº 55 "Edificio Burgosol"
E-28230 Las Rozas Madrid
Phone +34 / 91 64 07 30 2
Fax +34 / 62 90 54 62 9

Sweden

Amphenol Scandinavia
Johanneslundsvägen 2
194 61 Upplands Väsby
Phone +46 / 8 / 59 41 04 40
Fax +46 / 8 / 59 03 38 00

Switzerland

Amphenol Switzerland
Hintermättli 3
Gewerbepark
5506 Mägenwil
Phone ++41 / 628962525
Fax ++41 / 628962526

Taiwan

Amphenol Kai Jack
No. 110, Sec 1
Bao-An Road
Ren-Der Shiang
Tainan
Phone +886 / 6 / 266 / 10 11
Fax +886 / 6 / 266 / 46 33

The Netherlands

Amphenol Benelux b.v.
Hoofdveste 19
3992 AK Houten
Phone +31 / 30 / 6 35 80 00
Fax +31 / 30 / 6 37 78 99

USA

Amphenol Corporation
Corporate Headquarters
358 Hall Avenue
Wallingford, CT 06492
Phone +1 / 2 03 / 2 65 / 89 00
Fax +1 / 2 03 / 2 65 / 86 28

Your engineering sales representative:

Amphenol

Amphenol-Tuchel Electronics Representative Office

6900 Haggerty Road · Suite 200 · Canton, Michigan 48197 · Phone +1 / 734 / 451-6400 · Fax +1 / 734 / 451-7197 · <http://www.amphenol.com>
Toll free in the US: (800) 380 80 52