



## Features

- Radial Leaded Devices
- Cured, flame retardant epoxy polymer insulating material meets UL 94V-0 requirements
- RoHS compliant\*
- Agency recognition:   

## Applications

- Almost anywhere there is a low voltage power supply and a load to be protected, including:
- Computers & peripherals
  - General electronics
  - Automotive applications

# MF-R Series - PTC Resettable Fuses

## Electrical Characteristics

| Model        | V max. Volts | I max. Amps | I <sub>hold</sub> | I <sub>trip</sub> | Initial Resistance |       | 1 Hour (R <sub>1</sub> ) Post-Trip Resistance | Max. Time To Trip |                  | Tripped Power Dissipation |
|--------------|--------------|-------------|-------------------|-------------------|--------------------|-------|---|-------------------|------------------|---------------------------|
|              |              |             | Amperes at 23 °C  |                   | Ohms at 23 °C      |       | Ohms at 23 °C                                 | Amperes at 23 °C  | Seconds at 23 °C | Watts at 23 °C            |
|              |              |             | Hold              | Trip              | Min.               | Max.  | Max.  |                   |                  | Typ.                      |
| MF-R005**    | 60           | 40          | 0.05              | 0.10              | 7.3                | 11.1  | 22.0  | 0.5               | 5.0              | 0.22                      |
| MF-R010      | 60           | 40          | 0.10              | 0.20              | 2.50               | 4.50  | 7.50  | 0.5               | 4.0              | 0.38                      |
| MF-R017      | 60           | 40          | 0.17              | 0.34              | 2.00               | 3.20  | 8.00  | 0.85              | 3.0              | 0.48                      |
| MF-R020      | 60           | 40          | 0.20              | 0.40              | 1.50               | 2.84  | 4.40  | 1.0               | 2.2              | 0.40                      |
| MF-R025      | 60           | 40          | 0.25              | 0.50              | 1.00               | 1.95  | 3.00  | 1.25              | 2.5              | 0.45                      |
| MF-R030      | 60           | 40          | 0.30              | 0.60              | 0.76               | 1.36  | 2.10  | 1.5               | 3.0              | 0.50                      |
| MF-R040      | 60           | 40          | 0.40              | 0.80              | 0.52               | 0.86  | 1.29  | 2.0               | 3.8              | 0.55                      |
| MF-R050      | 60           | 40          | 0.50              | 1.00              | 0.41               | 0.77  | 1.17  | 2.5               | 4.0              | 0.75                      |
| MF-R065      | 60           | 40          | 0.65              | 1.30              | 0.27               | 0.48  | 0.72  | 3.25              | 5.3              | 0.90                      |
| MF-R075      | 60           | 40          | 0.75              | 1.50              | 0.18               | 0.40  | 0.60  | 3.75              | 6.3              | 0.90                      |
| MF-R090      | 60           | 40          | 0.90              | 1.80              | 0.14               | 0.31  | 0.47  | 4.5               | 7.2              | 1.00                      |
| MF-R090-0-9  | 30           | 40          | 0.90              | 1.80              | 0.07               | 0.12  | 0.22  | 4.5               | 5.9              | 0.60                      |
| MF-R110      | 30           | 40          | 1.10              | 2.20              | 0.10               | 0.18  | 0.27  | 5.5               | 6.6              | 0.70                      |
| MF-R135      | 30           | 40          | 1.35              | 2.70              | 0.065              | 0.115 | 0.17  | 6.75              | 7.3              | 0.80                      |
| MF-R160      | 30           | 40          | 1.60              | 3.20              | 0.055              | 0.105 | 0.15  | 8.0               | 8.0              | 0.90                      |
| MF-R185      | 30           | 40          | 1.85              | 3.70              | 0.040              | 0.07  | 0.11  | 9.25              | 8.7              | 1.00                      |
| MF-R250      | 30           | 40          | 2.50              | 5.00              | 0.025              | 0.048 | 0.07  | 12.5              | 10.3             | 1.20                      |
| MF-R250-0-10 | 30           | 40          | 2.50              | 5.00              | 0.025              | 0.048 | 0.07  | 12.5              | 10.3             | 1.20                      |
| MF-R300      | 30           | 40          | 3.00              | 6.00              | 0.020              | 0.05  | 0.08  | 15.0              | 10.8             | 2.00                      |
| MF-R400      | 30           | 40          | 4.00              | 8.00              | 0.010              | 0.03  | 0.05  | 20.0              | 12.7             | 2.50                      |
| MF-R500      | 30           | 40          | 5.00              | 10.00             | 0.010              | 0.03  | 0.05  | 25.0              | 14.5             | 3.00                      |
| MF-R600      | 30           | 40          | 6.00              | 12.00             | 0.005              | 0.02  | 0.04  | 30.0              | 16.0             | 3.50                      |
| MF-R700      | 30           | 40          | 7.00              | 14.00             | 0.005              | 0.02  | 0.03  | 35.0              | 17.5             | 3.80                      |
| MF-R800      | 30           | 40          | 8.00              | 16.00             | 0.005              | 0.02  | 0.03  | 40.0              | 18.8             | 4.00                      |
| MF-R900      | 30           | 40          | 9.00              | 18.00             | 0.005              | 0.01  | 0.02  | 45.0              | ***20.0          | 4.20                      |
| MF-R1100     | 16           | 100         | 11.00             | 22.00             | 0.003              | 0.01  | 0.014   | 40.0              | 20.0             | 4.50                      |

\*\*CSA approval pending.

\*\*\*Tested at 40 amps

## Environmental Characteristics

|  |   |
|--|---|
| Operating/Storage Temperature .....                          | -40 °C to +85 °C  |
| Maximum Device Surface Temperature<br>in Tripped State ..... | 125 °C  |
| Passive Aging.....   | +85 °C, 1000 hours .....±5 % typical resistance change          |
| Humidity Aging.....  | +85 °C, 85 % R.H. 1000 hours.....±5 % typical resistance change |
| Thermal Shock .....  | -40 °C to +85 °C, 10 times .....±10 % typical resistance change |
| Solvent Resistance .....                                     | MIL-STD-202, Method 215 .....No change                          |
| Vibration .....  | MIL-STD-883C, Method 2007.1, .....No change<br>Condition A      |

## Test Procedures And Requirements For Model MF-R Series

| Test                  | Test Conditions   | Accept/Reject Criteria                  |
|-----------------------|---|---|
| Visual/Mech. ....     | Verify dimensions and materials.....                      | Per MF physical description             |
| Resistance .....      | In still air @ 23 °C .....                                | R <sub>min</sub> ≤ R ≤ R <sub>max</sub> |
| Time to Trip .....    | 5 times I <sub>hold</sub> , V <sub>max</sub> , 23 °C..... | T ≤ max. time to trip (seconds)         |
| Hold Current .....    | 30 min. at I <sub>hold</sub> .....                        | No trip                                 |
| Trip Cycle Life ..... | V <sub>max</sub> , I <sub>max</sub> , 100 cycles .....    | No arcing or burning                    |
| Trip Endurance.....   | V <sub>max</sub> , 48 hours .....                         | No arcing or burning                    |

UL File Number .....E 174545S  
 CSA File Number .....CA 110338  
 TÜV File Number .....R2057213

\*RoHS Directive 2002/95/EC Jan 27 2003 including Annex. Product manufactured with a date code later than April 1, 2005 is RoHS compliant.  
 Specifications are subject to change without notice.

Customers should verify actual device performance in their specific applications.

## Additional Features

- Bulk packaging, tape and reel and Ammo-Pak available on most models
- Patents pending

# MF-R Series - PTC Resettable Fuses

# BOURNS®

Product Dimensions (see next page for outline drawing)

| Model        | A                                | B                                | C                                |                                    | D                                | E                                | Physical Characteristics |                                       |          |
|--------------|----------------------------------|----------------------------------|----------------------------------|------------------------------------|----------------------------------|----------------------------------|--------------------------|---------------------------------------|----------|
|              | Max.<br><u>          </u><br>( ) | Max.<br><u>          </u><br>( ) | Nom.<br><u>          </u><br>( ) | Tol. ±<br><u>          </u><br>( ) | Min.<br><u>          </u><br>( ) | Max.<br><u>          </u><br>( ) | Style                    | Lead Dia.<br><u>          </u><br>( ) | Material |
| MF-R005      | <u>8.0</u><br>(0.315)            | <u>8.3</u><br>(0.327)            | <u>5.1</u><br>(0.201)            | <u>0.7</u><br>(0.028)              | <u>7.6</u><br>(0.299)            | <u>3.1</u><br>(0.122)            | 4                        | <u>0.405</u><br>(0.016)               | Sn/NiCu  |
| MF-R010      | <u>7.4</u><br>(0.291)            | <u>12.7</u><br>(0.5)             | <u>5.1</u><br>(0.201)            | <u>0.7</u><br>(0.028)              | <u>7.6</u><br>(0.299)            | <u>3.1</u><br>(0.122)            | 1                        | <u>0.51</u><br>(0.020)                | Sn/NiCu  |
| MF-R017      | <u>7.4</u><br>(0.291)            | <u>12.7</u><br>(0.5)             | <u>5.1</u><br>(0.201)            | <u>0.7</u><br>(0.028)              | <u>7.6</u><br>(0.299)            | <u>3.1</u><br>(0.122)            | 1                        | <u>0.51</u><br>(0.020)                | Sn/CuFe  |
| MF-R020      | <u>7.4</u><br>(0.291)            | <u>12.7</u><br>(0.5)             | <u>5.1</u><br>(0.201)            | <u>0.7</u><br>(0.028)              | <u>7.6</u><br>(0.299)            | <u>3.1</u><br>(0.122)            | 1                        | <u>0.51</u><br>(0.020)                | Sn/CuFe  |
| MF-R025      | <u>7.4</u><br>(0.291)            | <u>12.7</u><br>(0.5)             | <u>5.1</u><br>(0.201)            | <u>0.7</u><br>(0.028)              | <u>7.6</u><br>(0.299)            | <u>3.1</u><br>(0.122)            | 1                        | <u>0.51</u><br>(0.020)                | Sn/CuFe  |
| MF-R030      | <u>7.4</u><br>(0.291)            | <u>13.4</u><br>(0.528)           | <u>5.1</u><br>(0.201)            | <u>0.7</u><br>(0.028)              | <u>7.6</u><br>(0.299)            | <u>3.1</u><br>(0.122)            | 1                        | <u>0.51</u><br>(0.020)                | Sn/CuFe  |
| MF-R040      | <u>7.4</u><br>(0.291)            | <u>13.7</u><br>(0.539)           | <u>5.1</u><br>(0.201)            | <u>0.7</u><br>(0.028)              | <u>7.6</u><br>(0.299)            | <u>3.1</u><br>(0.122)            | 1                        | <u>0.51</u><br>(0.020)                | Sn/CuFe  |
| MF-R050      | <u>7.9</u><br>(0.311)            | <u>13.7</u><br>(0.539)           | <u>5.1</u><br>(0.201)            | <u>0.7</u><br>(0.028)              | <u>7.6</u><br>(0.299)            | <u>3.1</u><br>(0.122)            | 1                        | <u>0.51</u><br>(0.020)                | Sn/Cu    |
| MF-R065      | <u>9.7</u><br>(0.382)            | <u>15.2</u><br>(0.598)           | <u>5.1</u><br>(0.201)            | <u>0.7</u><br>(0.028)              | <u>7.6</u><br>(0.299)            | <u>3.1</u><br>(0.122)            | 1                        | <u>0.51</u><br>(0.020)                | Sn/Cu    |
| MF-R075      | <u>10.4</u><br>(0.409)           | <u>16.0</u><br>(0.630)           | <u>5.1</u><br>(0.201)            | <u>0.7</u><br>(0.028)              | <u>7.6</u><br>(0.299)            | <u>3.1</u><br>(0.122)            | 1                        | <u>0.51</u><br>(0.020)                | Sn/Cu    |
| MF-R090      | <u>11.7</u><br>(0.461)           | <u>16.7</u><br>(0.657)           | <u>5.1</u><br>(0.201)            | <u>0.7</u><br>(0.028)              | <u>7.6</u><br>(0.299)            | <u>3.1</u><br>(0.122)            | 1                        | <u>0.51</u><br>(0.020)                | Sn/Cu    |
| MF-R090-0-9  | <u>7.4</u><br>(0.291)            | <u>12.2</u><br>(0.480)           | <u>5.1</u><br>(0.201)            | <u>0.7</u><br>(0.028)              | <u>7.6</u><br>(0.299)            | <u>3.0</u><br>(0.118)            | 3                        | <u>0.51</u><br>(0.020)                | Sn/CuFe  |
| MF-R110      | <u>8.9</u><br>(0.350)            | <u>14.0</u><br>(0.551)           | <u>5.1</u><br>(0.201)            | <u>0.7</u><br>(0.028)              | <u>7.6</u><br>(0.299)            | <u>3.0</u><br>(0.118)            | 1                        | <u>0.51</u><br>(0.020)                | Sn/Cu    |
| MF-R135      | <u>8.9</u><br>(0.350)            | <u>18.9</u><br>(0.744)           | <u>5.1</u><br>(0.201)            | <u>0.7</u><br>(0.028)              | <u>7.6</u><br>(0.299)            | <u>3.0</u><br>(0.118)            | 1                        | <u>0.51</u><br>(0.020)                | Sn/Cu    |
| MF-R160      | <u>10.2</u><br>(0.402)           | <u>16.8</u><br>(0.661)           | <u>5.1</u><br>(0.201)            | <u>0.7</u><br>(0.028)              | <u>7.6</u><br>(0.299)            | <u>3.0</u><br>(0.118)            | 1                        | <u>0.51</u><br>(0.020)                | Sn/Cu    |
| MF-R185      | <u>12.0</u><br>(0.472)           | <u>18.4</u><br>(0.724)           | <u>5.1</u><br>(0.201)            | <u>0.7</u><br>(0.028)              | <u>7.6</u><br>(0.299)            | <u>3.0</u><br>(0.118)            | 1                        | <u>0.51</u><br>(0.020)                | Sn/Cu    |
| MF-R250      | <u>12.0</u><br>(0.472)           | <u>18.3</u><br>(0.720)           | <u>5.1</u><br>(0.201)            | <u>0.7</u><br>(0.028)              | <u>7.6</u><br>(0.299)            | <u>3.0</u><br>(0.118)            | 2                        | <u>0.81</u><br>(0.032)                | Sn/Cu    |
| MF-R250-0-10 | <u>12.0</u><br>(0.472)           | <u>18.3</u><br>(0.720)           | <u>5.1</u><br>(0.201)            | <u>0.7</u><br>(0.028)              | <u>7.6</u><br>(0.299)            | <u>3.0</u><br>(0.118)            | 3                        | <u>0.51</u><br>(0.020)                | Sn/CuFe  |
| MF-R300      | <u>12.0</u><br>(0.472)           | <u>18.3</u><br>(0.720)           | <u>5.1</u><br>(0.201)            | <u>0.7</u><br>(0.028)              | <u>7.6</u><br>(0.299)            | <u>3.0</u><br>(0.118)            | 2                        | <u>0.81</u><br>(0.032)                | Sn/Cu    |
| MF-R400      | <u>14.4</u><br>(0.567)           | <u>24.8</u><br>(0.976)           | <u>5.1</u><br>(0.201)            | <u>0.7</u><br>(0.028)              | <u>7.6</u><br>(0.299)            | <u>3.0</u><br>(0.118)            | 2                        | <u>0.81</u><br>(0.032)                | Sn/Cu    |
| MF-R500      | <u>17.4</u><br>(0.685)           | <u>24.9</u><br>(0.980)           | <u>10.2</u><br>(0.402)           | <u>0.7</u><br>(0.028)              | <u>7.6</u><br>(0.299)            | <u>3.0</u><br>(0.118)            | 2                        | <u>0.81</u><br>(0.032)                | Sn/Cu    |
| MF-R600      | <u>19.3</u><br>(0.760)           | <u>31.9</u><br>(1.256)           | <u>10.2</u><br>(0.402)           | <u>0.7</u><br>(0.028)              | <u>7.6</u><br>(0.299)            | <u>3.0</u><br>(0.118)            | 2                        | <u>0.81</u><br>(0.032)                | Sn/Cu    |
| MF-R700      | <u>22.1</u><br>(0.870)           | <u>29.8</u><br>(1.173)           | <u>10.2</u><br>(0.402)           | <u>0.7</u><br>(0.028)              | <u>7.6</u><br>(0.299)            | <u>3.0</u><br>(0.118)            | 2                        | <u>0.81</u><br>(0.032)                | Sn/Cu    |
| MF-R800      | <u>24.2</u><br>(0.953)           | <u>32.9</u><br>(1.295)           | <u>10.2</u><br>(0.402)           | <u>0.7</u><br>(0.028)              | <u>7.6</u><br>(0.299)            | <u>3.0</u><br>(0.118)            | 2                        | <u>0.81</u><br>(0.032)                | Sn/Cu    |
| MF-R900      | <u>24.2</u><br>(0.953)           | <u>32.9</u><br>(1.295)           | <u>10.2</u><br>(0.402)           | <u>0.7</u><br>(0.028)              | <u>7.6</u><br>(0.299)            | <u>3.0</u><br>(0.118)            | 2                        | <u>0.81</u><br>(0.032)                | Sn/Cu    |
| MF-R1100     | <u>24.2</u><br>(0.953)           | <u>32.9</u><br>(1.295)           | <u>10.2</u><br>(0.402)           | <u>0.7</u><br>(0.028)              | <u>7.6</u><br>(0.299)            | <u>3.0</u><br>(0.118)            | 2                        | <u>0.81</u><br>(0.032)                | Sn/Cu    |

Packaging options: BULK: All models = 500 pcs. per bag.  
 TAPE & REEL: MF-R005-MF-R160 - 12.7 mm device pitch = 3000 pcs. per reel;  
 MF-R185-MF-R400 - 25.4mm device pitch = 1500 pcs. per reel; MF-R250-0-10 = 1500 pcs. per reel.  
 AMMO-PACK: MF-R005-MF-R160 - 12.7 mm device pitch = 2000 pcs. per reel;  
 MF-R185-MF-R400 - 25.4 mm device pitch = 1000 pcs. per reel; MF-R090-0-9 & MF-R250-0-10 = 2000 pcs. per reel.

DIMENSIONS =  $\frac{\text{MM}}{\text{(INCHES)}}$   
 0.405 (26AWG)  
 0.51 (24AWG)  
 0.81 (20AWG)

Specifications are subject to change without notice.  
 Customers should verify actual device performance in their specific applications.

# MF-R Series - PTC Resettable Fuses

**BOURNS®**

## Product Dimensions (see previous page for dimensions)

Style 1

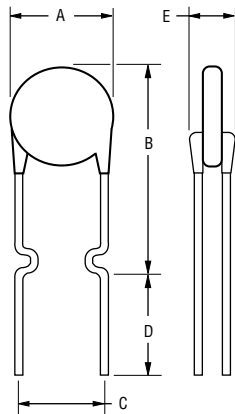

Style 2

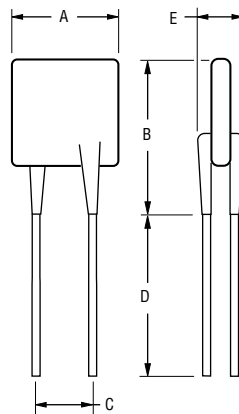

Style 3

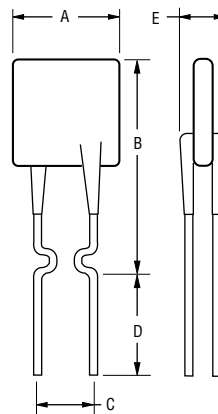

Style 4

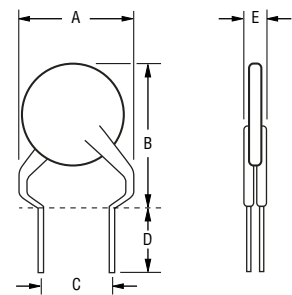

NOTE: Kinked lead option is available for board standoff. Contact factory for details.

NOTE: Also available with straight leads. Contact factory for details.

## Thermal Derating Chart - $I_{hold}$ / $I_{trip}$ (Amps)

| Model        | Ambient Operating Temperature |             |             |             |             |             |             |             |             |
|--------------|-------------------------------|-------------|-------------|-------------|-------------|-------------|-------------|-------------|-------------|
|              | -40 °C                        | -20 °C      | 0 °C        | 23 °C       | 40 °C       | 50 °C       | 60 °C       | 70 °C       | 85 °C       |
| MF-R005      | 0.08 / 0.16                   | 0.07 / 0.14 | 0.06 / 0.12 | 0.05 / 0.10 | 0.04 / 0.08 | 0.04 / 0.08 | 0.03 / 0.07 | 0.03 / 0.07 | 0.02 / 0.05 |
| MF-R010      | 0.16 / 0.32                   | 0.14 / 0.28 | 0.12 / 0.24 | 0.10 / 0.20 | 0.08 / 0.16 | 0.07 / 0.14 | 0.06 / 0.12 | 0.05 / 0.10 | 0.04 / 0.08 |
| MF-R017      | 0.26 / 0.52                   | 0.23 / 0.46 | 0.20 / 0.40 | 0.17 / 0.34 | 0.14 / 0.28 | 0.12 / 0.24 | 0.11 / 0.22 | 0.09 / 0.18 | 0.07 / 0.14 |
| MF-R020      | 0.31 / 0.62                   | 0.27 / 0.54 | 0.24 / 0.48 | 0.20 / 0.40 | 0.16 / 0.32 | 0.14 / 0.28 | 0.13 / 0.26 | 0.11 / 0.22 | 0.08 / 0.16 |
| MF-R025      | 0.39 / 0.78                   | 0.34 / 0.68 | 0.30 / 0.60 | 0.25 / 0.50 | 0.20 / 0.40 | 0.18 / 0.36 | 0.16 / 0.32 | 0.14 / 0.28 | 0.10 / 0.20 |
| MF-R030      | 0.47 / 0.94                   | 0.41 / 0.82 | 0.36 / 0.72 | 0.30 / 0.60 | 0.24 / 0.48 | 0.22 / 0.44 | 0.19 / 0.38 | 0.16 / 0.32 | 0.12 / 0.24 |
| MF-R040      | 0.62 / 1.24                   | 0.54 / 1.08 | 0.48 / 0.96 | 0.40 / 0.80 | 0.32 / 0.64 | 0.29 / 0.58 | 0.25 / 0.50 | 0.22 / 0.44 | 0.16 / 0.32 |
| MF-R050      | 0.78 / 1.56                   | 0.68 / 1.36 | 0.60 / 1.20 | 0.50 / 1.00 | 0.41 / 0.82 | 0.36 / 0.72 | 0.32 / 0.64 | 0.27 / 0.54 | 0.20 / 0.40 |
| MF-R065      | 1.01 / 2.02                   | 0.88 / 1.76 | 0.77 / 1.54 | 0.65 / 1.30 | 0.53 / 1.06 | 0.47 / 0.94 | 0.41 / 0.82 | 0.35 / 0.70 | 0.26 / 0.52 |
| MF-R075      | 1.16 / 2.32                   | 1.02 / 2.04 | 0.89 / 1.78 | 0.75 / 1.50 | 0.61 / 1.22 | 0.54 / 1.08 | 0.47 / 0.94 | 0.41 / 0.82 | 0.30 / 0.60 |
| MF-R090      | 1.40 / 2.80                   | 1.22 / 2.44 | 1.07 / 2.14 | 0.90 / 1.80 | 0.73 / 1.46 | 0.65 / 1.30 | 0.57 / 1.14 | 0.49 / 0.98 | 0.36 / 0.72 |
| MF-R090-0-9  | 1.40 / 2.80                   | 1.22 / 2.44 | 1.07 / 2.14 | 0.90 / 1.80 | 0.73 / 1.46 | 0.65 / 1.30 | 0.57 / 1.14 | 0.49 / 0.98 | 0.36 / 0.72 |
| MF-R110      | 1.60 / 3.20                   | 1.43 / 2.86 | 1.27 / 2.54 | 1.10 / 2.20 | 0.91 / 1.82 | 0.85 / 1.70 | 0.75 / 1.50 | 0.67 / 1.34 | 0.57 / 1.14 |
| MF-R135      | 1.96 / 3.92                   | 1.76 / 3.52 | 1.55 / 3.10 | 1.35 / 2.70 | 1.12 / 2.24 | 1.04 / 2.08 | 0.92 / 1.84 | 0.82 / 1.64 | 0.70 / 1.40 |
| MF-R160      | 2.32 / 4.64                   | 2.08 / 4.16 | 1.84 / 3.68 | 1.60 / 3.20 | 1.33 / 2.66 | 1.23 / 2.46 | 1.09 / 2.18 | 0.98 / 1.96 | 0.83 / 1.66 |
| MF-R185      | 2.68 / 5.36                   | 2.41 / 4.82 | 2.13 / 4.26 | 1.85 / 3.70 | 1.54 / 3.08 | 1.42 / 2.84 | 1.26 / 2.52 | 1.13 / 2.26 | 0.96 / 1.92 |
| MF-R250      | 3.63 / 7.26                   | 3.25 / 6.50 | 2.88 / 5.76 | 2.50 / 5.00 | 2.08 / 4.16 | 1.93 / 3.86 | 1.70 / 3.40 | 1.53 / 3.06 | 1.30 / 2.60 |
| MF-R250-0-10 | 3.63 / 7.26                   | 3.25 / 6.50 | 2.88 / 5.76 | 2.50 / 5.00 | 2.08 / 4.16 | 1.93 / 3.86 | 1.70 / 3.40 | 1.53 / 3.06 | 1.30 / 2.60 |
| MF-R300      | 4.35 / 8.70                   | 3.90 / 7.80 | 3.45 / 6.90 | 3.00 / 6.00 | 2.49 / 4.98 | 2.31 / 4.62 | 2.04 / 4.08 | 1.83 / 3.66 | 1.56 / 3.12 |
| MF-R400      | 5.80 / 11.6                   | 5.20 / 10.4 | 4.60 / 9.20 | 4.00 / 8.00 | 3.32 / 6.64 | 3.08 / 6.16 | 2.72 / 5.44 | 2.44 / 4.88 | 2.08 / 4.16 |
| MF-R500      | 7.25 / 14.5                   | 6.50 / 13.0 | 5.75 / 11.5 | 5.00 / 10.0 | 4.15 / 8.30 | 3.85 / 7.70 | 3.40 / 6.80 | 3.05 / 6.10 | 2.60 / 5.20 |
| MF-R600      | 8.70 / 17.4                   | 7.80 / 15.6 | 6.90 / 13.8 | 6.00 / 12.0 | 4.98 / 9.96 | 4.62 / 9.24 | 4.08 / 8.16 | 3.66 / 7.32 | 3.12 / 6.24 |
| MF-R700      | 10.1 / 20.3                   | 9.10 / 18.2 | 8.05 / 16.1 | 7.00 / 14.0 | 5.81 / 11.6 | 5.39 / 10.7 | 4.76 / 9.52 | 4.27 / 9.44 | 3.64 / 7.28 |
| MF-R800      | 11.6 / 23.2                   | 10.4 / 20.8 | 9.20 / 18.4 | 8.00 / 16.0 | 6.64 / 13.2 | 6.16 / 12.3 | 5.44 / 10.8 | 4.88 / 9.76 | 4.16 / 8.32 |
| MF-R900      | 13.0 / 26.1                   | 11.7 / 23.4 | 10.3 / 20.7 | 9.00 / 18.0 | 7.47 / 14.9 | 6.93 / 12.7 | 6.12 / 12.2 | 5.49 / 10.9 | 4.68 / 9.36 |
| MF-R1100     | 16.1 / 32.0                   | 14.6 / 29.2 | 13.1 / 26.2 | 11.0 / 22.1 | 9.40 / 18.4 | 8.80 / 17.6 | 7.80 / 15.6 | 6.90 / 13.8 | 5.20 / 10.4 |

Specifications are subject to change without notice. Customers should verify actual device performance in their specific applications.

# MF-R Series - PTC Resettable Fuses

**BOURNS®**

## Typical Time to Trip at 23 °C

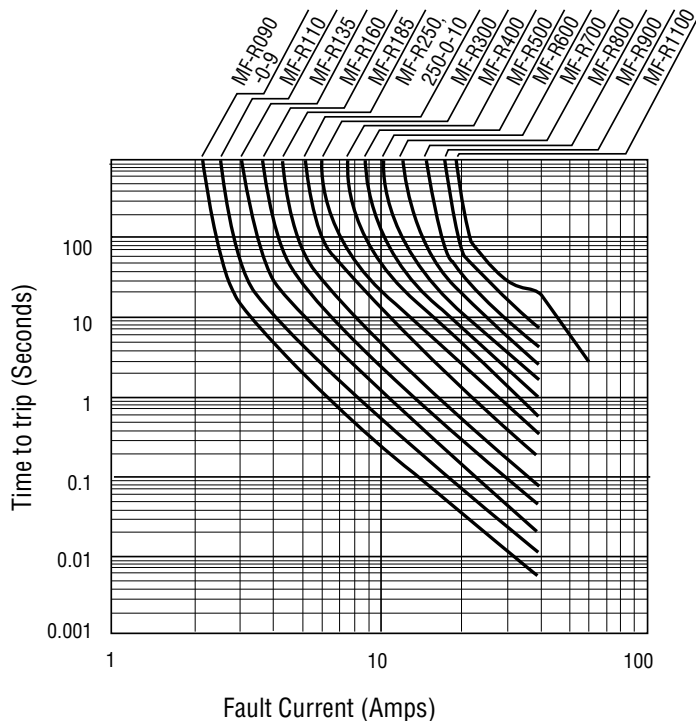
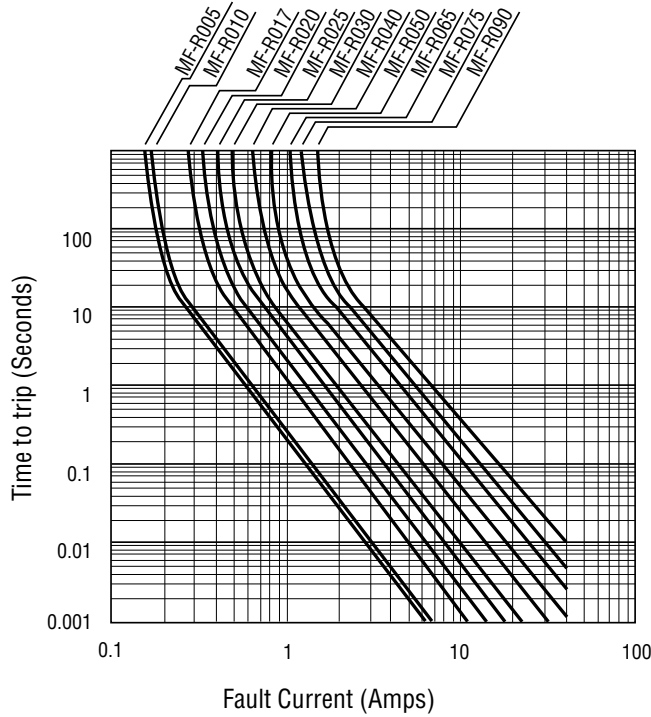

Specifications are subject to change without notice.  
Customers should verify actual device performance in their specific applications.

## How to Order

**MF - R 110 - 0 - 99**

Multifuse®  
Product Designator \_\_\_\_\_  
Series \_\_\_\_\_  
R = Radial Leaded Component  
Hold Current, I<sub>hold</sub> \_\_\_\_\_  
005-1100 (0.05 Amps - 11.0 Amps)  
Packaging Options \_\_\_\_\_  
- = Bulk Packaging without part number suffix option  
- 0-99 = Bulk Packaging with part number suffix option  
- 2 = Tape and Reel without part number suffix option\*  
- 2-99 = Tape and Reel with part number suffix option  
- AP = Ammo-Pak\*  
- 0-14 = Kinked leads where straight leads are standard  
- 0-17 = Straight leads where kinked leads are standard  
Part Number Suffix Option \_\_\_\_\_  
- 99 = As of date code April 1, 2005 all MF-R models are RoHS compliant. The suffix "-99" can be used if a new part number is required to reference the RoHS compliance.  
Examples:  
MF-R110 .....Bulk packaging  
MF-R110-0-99 .....Bulk packaging with part number suffix option  
MF-R110-2 .....Tape and reel packaging  
MF-R110-2-99 .....Tape and reel packaging with part number suffix option  
MF-R090-0-9-99 .....Bulk packaging with part number suffix option  
MF-R250-0-10-99 .....Bulk packaging with part number suffix option

\*Packaged per EIA486-B

## Typical Part Marking: MF-R005 - R025

Represents total content. Layout may vary.

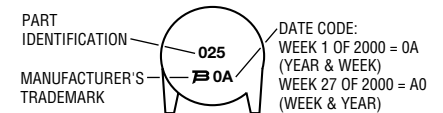

## Typical Part Marking: MF-R030 - R1100

Represents total content. Layout may vary.

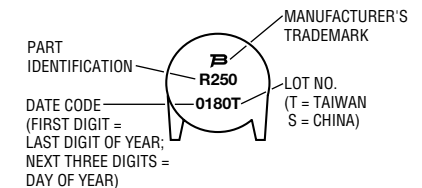

MF-R SERIES, REV. W, 04/08

**MF-R, MF-R/90, MF-R/600, MF-RX, MF-RX/72 & MF-RX/250 Series  
Tape and Reel Specifications**

**BOURNS®**

Devices taped using EIA468-B/IEC286-2 standards. See table below and Figures 1 and 2 for details.

| Dimension Description  | IEC Mark   | EIA Mark   | Dimensions             |  |
|--|------------|------------|------------------------|--|
|  |            |            | Dimensions             | Tolerance  |
| Carrier tape width   | $W$        | $W$        | $\frac{18}{(.709)}$    | $\frac{-0.5/+1.0}{(-0.02/+0.039)}$                           |
| Hold down tape width:  | $W_0$      | $W_4$      | $\frac{11}{(.433)}$    | min.   |
| Hold down tape   |            |            | No protrusion          |  |
| Top distance between tape edges  | $W_2$      | $W_6$      | $\frac{3}{(.118)}$     | max.   |
| Sprocket hole position   | $W_1$      | $W_5$      | $\frac{9}{(.354)}$     | $\frac{-0.5/+0.75}{(-0.02/+0.03)}$                           |
| Sprocket hole diameter   | $D_0$      | $D_0$      | $\frac{4}{(.157)}$     | $\frac{\pm 0.2}{(\pm .0078)}$                                |
| Abscissa to plane (straight lead)  | $H$        | $H$        | $\frac{18.5}{(.728)}$  | $\frac{\pm 3.0}{(\pm .118)}$                                 |
| Abscissa to plane (kinked lead)  | $H_0$      | $H_0$      | $\frac{16}{(.63)}$     | $\frac{\pm 0.5}{(\pm .02)}$                                  |
| Abscissa to top (straight lead)  | $H_1$      | $H_1$      | $\frac{38.0}{(1.496)}$ | max.   |
| Abscissa to top (kinked lead)  | $H_1$      | $H_1$      | $\frac{32.2}{(1.268)}$ | max.   |
| Overall width w/lead protrusion (straight lead)  |            | $C_1$      | $\frac{55.0}{(2.165)}$ | max.   |
| Overall width w/lead protrusion (kinked lead)  |            | $C_1$      | $\frac{43.2}{(1.7)}$   | max.   |
| Overall width w/o lead protrusion (straight lead)  |            | $C_2$      | $\frac{54.0}{(2.126)}$ | max.   |
| Overall width w/o lead protrusion (kinked lead)  |            | $C_2$      | $\frac{42.5}{(1.673)}$ | max.   |
| Lead protrusion  | $I_1$      | $L_1$      | $\frac{1.0}{(.039)}$   | max.   |
| Protrusion of cutout   | $L$        | $L$        | $\frac{11}{(.433)}$    | max.   |
| Protrusion beyond hold tape  | $I_2$      | $I_2$      | Not specified          |  |
| Sprocket hole pitch  | $P_0$      | $P_0$      | $\frac{12.7}{(0.5)}$   | $\frac{\pm 0.3}{(\pm .012)}$                                 |
| Pitch tolerance  |            |            | 20 consecutive         | $\frac{\pm 1}{(\pm .039)}$                                   |
| Device pitch: MF-R005-MF-R160, MF-R/90, MF-RX110/72-MF-RX185/72                                  |            |            | $\frac{12.7}{(0.5)}$   | $\frac{\pm 0.3}{(\pm .012)}$                                 |
| Device pitch: MF-R185-MF-R400, MF-RX110-MF-RX375 MF-R/600, MF-RX250/72-MF-RX375/72               |            |            | $\frac{25.4}{(1.0)}$   | $\frac{\pm 0.6}{(\pm .024)}$                                 |
| Tape thickness   | $t$        | $t$        | $\frac{0.9}{(.035)}$   | max.   |
| Tape thickness with splice: MF-R010-MF-R160, MF-RX110/72-MF-RX185/72,                            |            | $t_1$      | $\frac{1.5}{(.059)}$   | max.   |
| Tape thickness with splice: MF-R250-MF-R1100 MF-RX110-MF-RX375, MF-R/90, MF-RX250/72-MF-RX375/72 |            | $t_1$      | $\frac{2.3}{(.091)}$   | max.   |
| Splice sprocket hole alignment   |            |            | 0                      | $\frac{\pm 0.3}{(\pm .012)}$<br>$\frac{\pm 1.0}{(\pm .039)}$ |
| Body lateral deviation   | $\Delta h$ | $\Delta h$ | 0                      | $\frac{\pm 1.3}{(\pm .051)}$                                 |
| Body tape plane deviation  | $\Delta p$ | $\Delta p$ | 0                      | $\frac{\pm 0.2}{(\pm .008)}$                                 |
| Lead spacing   | $F$        | $F$        | $\frac{5.08}{(0.2)}$   | $\frac{\pm 0.2}{(\pm .008)}$                                 |
| Reel width   | $w$        | $W_2$      | $\frac{56}{(2.205)}$   | max.   |
| Reel diameter  | $d$        | $a$        | $\frac{370}{(14.57)}$  | max.   |
| Space between flanges less device  | $W_1$      | $h$        | $\frac{4.75}{(.187)}$  | $\frac{\pm 3.25}{(\pm .128)}$                                |

Specifications are subject to change without notice.

Customers should verify actual device performance in their specific applications.

DIMENSIONS =  $\frac{\text{MM}}{\text{(INCHES)}}$

| Dimension Description                            | IEC Mark | EIA Mark | Dimensions   |                               |
|--|----------|----------|--|-------------------------------|
|  |          |          | Dimensions   | Tolerance                     |
| Arbor hole diameter                              | <i>f</i> | <i>c</i> | $\frac{26}{(1.024)}$   | $\frac{\pm 12.0}{(\pm .472)}$ |
| Core diameter: MF-R, MF-RX, MF-R/90              | <i>h</i> | <i>n</i> | $\frac{80}{(3.15)}$  | max.                          |
| Core diameter: MF-RX/250, MF-R/600               | <i>h</i> | <i>n</i> | $\frac{91}{(3.58)}$  | max.                          |
| Box: MF-R, MF-RX, MF-R/90                        |          |          | $\frac{56}{(2.2)}$ $\frac{372}{(14.6)}$ $\frac{372}{(14.6)}$   | max.                          |
| Box: MF-RX/250                                   |          |          | $\frac{67}{(2.64)}$ $\frac{372}{(14.6)}$ $\frac{362}{(14.25)}$ | max.                          |
| Box: MF-R/600                                    |          |          | $\frac{64}{(2.52)}$ $\frac{372}{(14.6)}$ $\frac{362}{(14.25)}$ | max.                          |
| Consecutive missing places: MF-R, MF-RX, MF-R/90 |          |          | 3  | max.                          |
| Consecutive missing places: MF-RX/250, MF-R/600  |          |          | none   |                               |
| Empty places per reel: MF-R, MF-RX, MF-R/90      |          |          | Not specified  |                               |
| Empty places per reel: MF-RX/250, MF-R/600       |          |          | 0.1 %  |                               |

**Taped Component Dimensions - Figure 1**

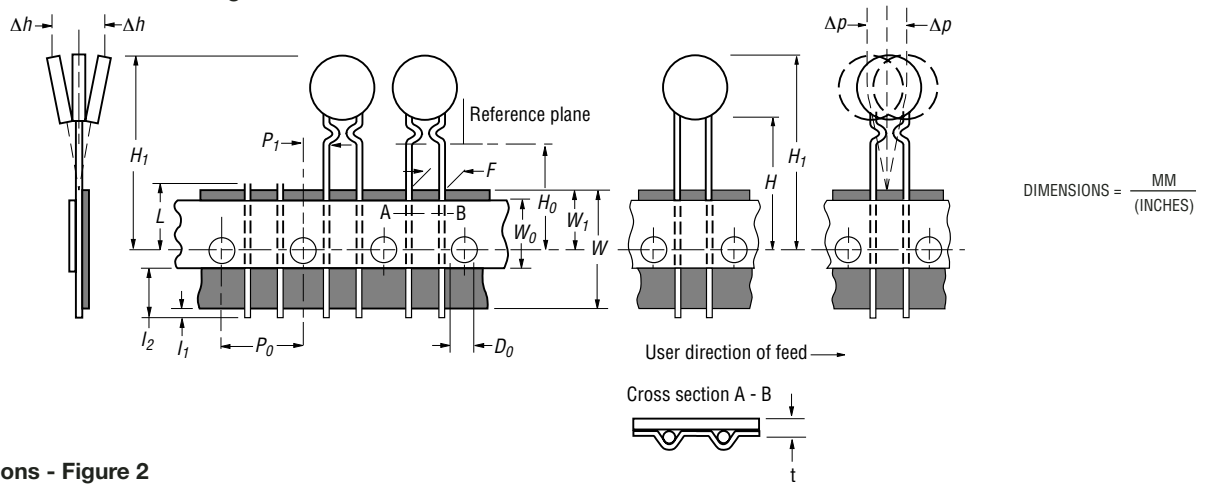

**Reel Dimensions - Figure 2**

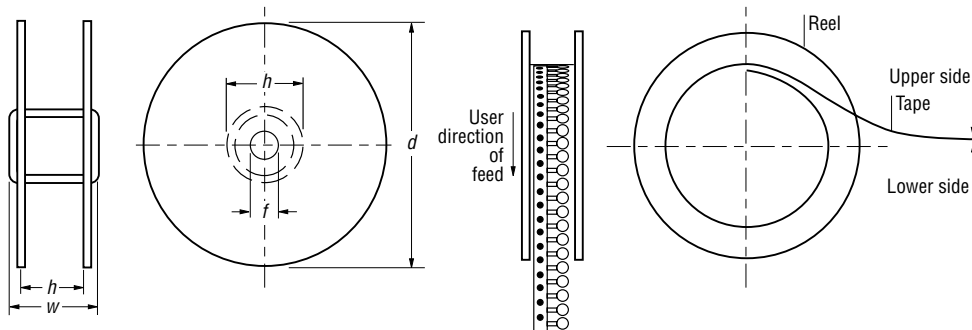

Specifications are subject to change without notice.  
Customers should verify actual device performance in their specific applications.