

FEATURES

- **SUPPLY VOLTAGE**
 $V_{CC} = 2.4$ to 3.3 V
- **OPERATING FREQUENCY**
 $f_{IN} = 50$ to 700 MHz at $\div 2$
 50 to 800 MHz at $\div 4$
- **LOW CURRENT CONSUMPTION**
 3.5 mA at $V_{CC} = 3.0$ V
- **SELECTABLE DIVISION**
 $\div 2, \div 4$
- **HIGH-DENSITY SURFACE MOUNTING**
6-pin super minimold

DESCRIPTION

The UPB1511TB is a silicon monolithic integrated circuit designed as a divide by 2,4 prescaler IC for portable radio systems. This IC is manufactured using NEC's 30 GHz f_{MAX} UHS0 (Ultra High Speed Process) silicon bipolar process.

Consequently, this IC is lower circuit current and smaller package than conventional UPB1509GV. The low power makes this device ideally suited for cellular and cordless telephone applications.

NEC's stringent quality assurance and test procedures ensure the highest reliability and performance.

TEST CIRCUIT

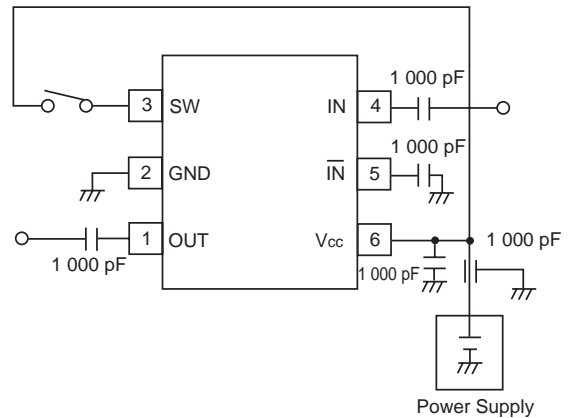

APPLICATIONS

- Portable radio systems
- Cellular/cordless telephone 2nd local prescaler

ELECTRICAL CHARACTERISTICS ($T_A = +25^\circ\text{C}$, $V_{CC} = 3.0$ V)

PART NUMBER PACKAGE OUTLINE			UPB1511TB		
SYMBOLS	PARAMETERS AND CONDITIONS	UNITS	MIN	TYP	MAX
I_{CC}	Circuit Current, No Signals	mA	3.1	3.5	4.1
$f_{IN}(u)1$	Upper Limit Operating Frequency 1, $P_{IN} = -20$ to 0 dBm	MHz	500		
$f_{IN}(u)2$	Upper Limit Operating Frequency 2, $P_{IN} = -20$ to -5 dBm @ $\div 2$ @ $\div 4$	MHz	700 800		
$f_{IN}(L)1$	Lower Limit Operating Frequency 1, $P_{IN} = -20$ to 0 dBm	MHz			50
$f_{IN}(L)2$	Lower Limit Operating Frequency 2, $P_{IN} = -20$ to -5 dBm	MHz			500
P_{IN1}	Input Power 1, $f_{IN} = 50$ to 800 MHz	dBm	-20		-5
P_{IN2}	Input Power 2, $f_{IN} = 50$ to 500 MHz	dBm	-20		0
V_{OUT}	Output Voltage, $R_L = 200 \Omega$	V _{P-P}	0.2	0.3	
V_{IH}	Divide Ratio Control Input High	V	$0.7 \times V_{CC}$		$V_{CC} + 0.5$
V_{IL}	Divide Ratio Control Input Low	V	-0.5		$V_{CC} \times 0.3$

UPB1511TB

ABSOLUTE MAXIMUM RATINGS¹

SYMBOLS	PARAMETERS	UNITS	RATINGS
V _{CC}	Supply Voltage T _A = +25° C	V	3.6
V _{IN}	Input Voltage T _A = +25° C, SW Pin	V	3.6
P _D	Total Power Dissipation ² (T _A = +85° C)	mW	200
T _A	Operating Ambient Temp.	°C	-40 to +85
T _{STG}	Storage Temperature	°C	-55 to +150

Notes:

1. Operation in excess of any one of these conditions may result in permanent damage.
2. Mounted on double sided copper clad 50 x 50 x 1.6mm epoxy glass PWB

INTERNAL BLOCK DIAGRAM

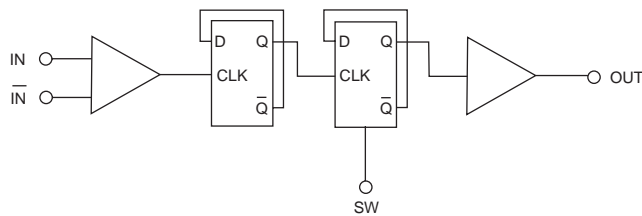

PRODUCT LINE-UP

PART NUMBER	I _{CC} (mA)	V _{CC} (V)	÷2 f _{IN} (MHz)	÷4 f _{IN} (MHz)	÷8 f _{IN} (MHz)	PACKAGE
UPB1509 GV	5.0	2.2 to 5.5	50 to 700	50 to 800	50 to 1000	8-pin SSOP
UPB1511 TB	3.5	2.4 to 3.3	50 to 700	50 to 800	-	6-pin super minimold

PIN EXPLANATIONS

PIN NO.	SYMBOL	APPLIED VOLTAGE (V)	FUNCTIONS AND EXPLANATION						
1	OUT	-	Divided Frequency Output Pin. This pin is designed as an emitter follower output and can deliver 0.2 V _{P-P} minimum into a 200 Ω load. This pin should be coupled to the load device with a capacitor (example: 1000 pF) for DC cut.						
2	GND	0	Ground Pin. Ground pattern on the board should be as wide as possible to minimize ground impedance.						
3	SW	H/L	Divide Ratio Control Pin. Divide ratio can be determined by the following applied level to these pins. <table border="1" style="margin: 10px auto;"> <thead> <tr> <th colspan="2">SW</th> </tr> <tr> <th>H</th> <th>L</th> </tr> </thead> <tbody> <tr> <td>Divide ratio</td> <td>1/4</td> </tr> </tbody> </table> These pins must be each equipped with bypass capacitor to minimize their impedance.	SW		H	L	Divide ratio	1/4
SW									
H	L								
Divide ratio	1/4								
4	IN	-	Signal Input Pin. This pin should be coupled to the signal source with a capacitor (example: 1000 pF) for DC cut.						
5	IN̄	-	Signal Input Bypass Pin. This pin must be equipped with a bypass capacitor (example: 1000 pF) to minimize ground impedance.						
6	V _{CC}	2.4 TO 3.3	Power Supply Pin. This pin must be equipped with a bypass capacitor (example: 1000 pF) to minimize ground impedance.						

RECOMMENDED OPERATING CONDITIONS

SYMBOLS	PARAMETERS	UNITS	MIN	TYP	MAX
V _{CC}	Supply Voltage	V	2.4	3.0	3.3
T _A	Operating Ambient Temp.	°C	-40	+25	+85

SYSTEM APPLICATION EXAMPLE

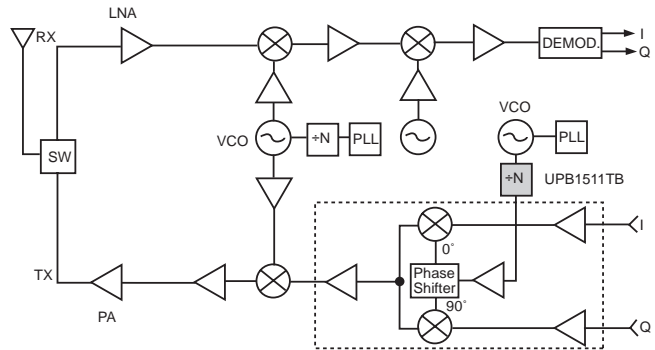

OUTLINE DIMENSIONS (Units in mm)

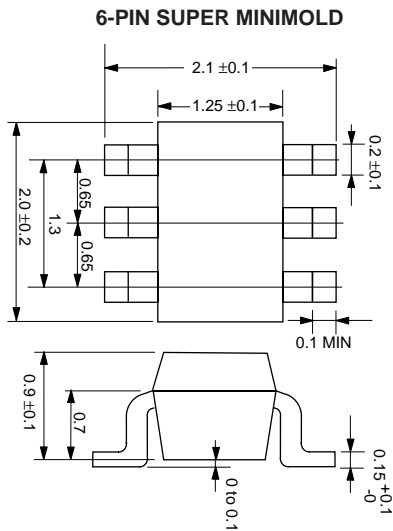

PIN CONNECTIONS

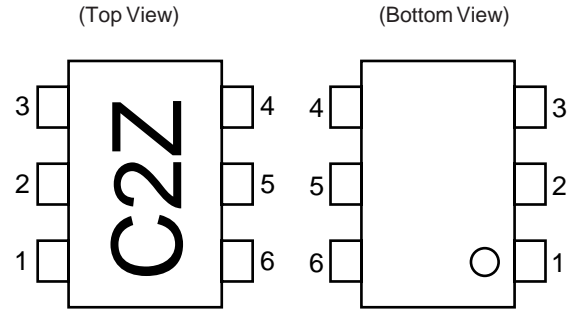

PIN CONNECTION

- 1. OUT
- 2. GND
- 3. SW
- 4. IN
- 5. $\overline{\text{IN}}$
- 6. Vcc

TEST CIRCUIT

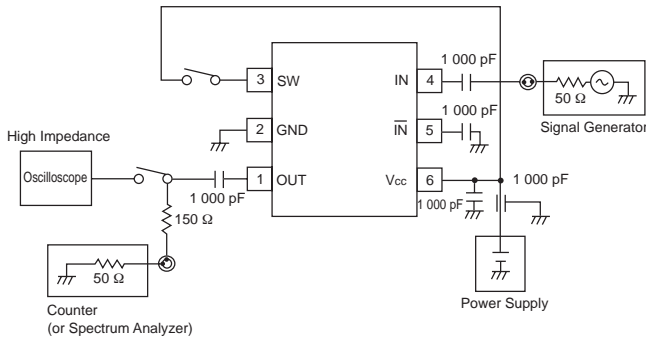

Divide Ratio Setting

SW	H	1/2
	L	1/4

ORDERING INFORMATION

PART NUMBER	PACKAGE	QUANTITY
UPB1511TB-E3	6-pin super minimold	Qty 3 kpcs/reel.

Notes:

- 1. Embossed tape 8 mm wide. Pin 1, 2, 3 face the tape perforation side.

Life Support Applications

These NEC products are not intended for use in life support devices, appliances, or systems where the malfunction of these products can reasonably be expected to result in personal injury. The customers of CEL using or selling these products for use in such applications do so at their own risk and agree to fully indemnify CEL for all damages resulting from such improper use or sale.

EXCLUSIVE NORTH AMERICAN AGENT FOR **NEC** RF, MICROWAVE & OPTOELECTRONIC SEMICONDUCTORS

CEL CALIFORNIA EASTERN LABORATORIES • Headquarters • 4590 Patrick Henry Drive • Santa Clara, CA 95054-1817 • (408) 988-3500 • Telex 34-6393 • FAX (408) 988-0279
 DATA SUBJECT TO CHANGE WITHOUT NOTICE

Internet: <http://WWW.CEL.COM>

07/18/2002