



# DATASHEET

# AX5151

Version 1.0

Document	Type	Datasheet
Document	Status	
Document	Version	Version 1.0
Product		AX5151

## Table of Contents

<b>1. Overview</b> .....	<b>6</b>
1.1. Features .....	6
1.2. Applications .....	6
<b>2. Block Diagram</b> .....	<b>7</b>
<b>3. Pin Function Descriptions</b> .....	<b>8</b>
3.1. Pinout Drawing .....	9
<b>4. Specifications</b> .....	<b>10</b>
4.1. Absolute Maximum Ratings.....	10
4.2. DC Characteristics.....	11
Supplies .....	11
Logic .....	12
4.3. AC Characteristics.....	13
Crystal Oscillator .....	13
RF Frequency Generation Subsystem (Synthesizer) .....	14
Transmitter.....	15
Receiver .....	16
SPI Timing.....	18
<b>5. Circuit Description</b> .....	<b>19</b>
5.1. Voltage Regulator .....	20
5.2. Crystal Oscillator.....	20
5.3. SYSCLK Output.....	21
5.4. Power-on-reset (POR) and RESET_N Input .....	21
5.5. RF Frequency Generation Subsystem.....	21
VCO .....	22
VCO Auto-Ranging .....	22
Loop Filter and Charge Pump.....	22

Registers .....	22
5.6. RF Input and Output Stage (ANTP/ANTN) .....	23
LNA.....	23
I/Q Mixer.....	23
PA.....	23
5.7. Analog IF Filter .....	23
5.8. Digital IF Channel Filter and Demodulator.....	23
Registers .....	24
5.9. Encoder .....	24
5.10. Framing and FIFO .....	25
HDLC Mode.....	26
RAW Mode.....	26
RAW Mode with Preamble Match.....	26
802.15.4 (ZigBee).....	27
5.11. RX AGC and RSSI .....	27
5.12. Modulator .....	28
5.13. Automatic Frequency Control (AFC) .....	28
5.14. PWRMODE Register .....	29
5.15. Serial Peripheral Interface (SPI) .....	31
SPI Timing.....	31
<b>6. Register Bank Description.....</b>	<b>32</b>
6.1. Control Register Map.....	33
<b>7. Application Information.....</b>	<b>37</b>
7.1. Typical Application Diagram .....	37
7.2. Antenna Interface Circuitry.....	38
Single-Ended Antenna Interface .....	38
Dipole Antenna Interface .....	39
7.3. Voltage Regulator .....	39

<b>8. TSSOP24 Package Information .....</b>	<b>40</b>
8.1. Package Outline TSSOP24 .....	40
<b>9. Life Support Applications .....</b>	<b>42</b>
<b>10. Contact Information .....</b>	<b>43</b>

## 1. Overview

### 1.1. Features

- Advanced multi-channel single chip UHF transceiver
- Configurable for usage in 400-470 MHz and 800-930 MHz SRD bands
- Wide variety of shaped modulations supported in RX and TX (ASK, PSK, MSK, FSK)
- Data rates from 38.4 to 200 kbps (FSK, MSK) and to 600 kbps (ASK, PSK)
- Ultra fast settling RF frequency synthesizer for low-power consumption
- Variable channel filtering from 40 kHz to 600 kHz
- 802.15.4 compatible
- RF carrier frequency and FSK deviation programmable in 1 Hz steps
- Fully integrated RF frequency synthesizer with VCO auto-ranging and band-width boost modes for fast locking
- Few external components
- On chip communication controller and flexible digital modem
- Channel hopping up to 2000 hops/s
- Up to +11 dBm programmable transmitter power amplifier for long range operation
- Sensitivity down to -99 dBm at 100 kbps
- Crystal oscillator with programmable transconductance and programmable internal tuning capacitors for low cost crystals
- Automatic frequency control (AFC)
- SPI micro-controller interface

- Fully integrated current/voltage references
- TSSOP24 package
- Low power receiver: 20 - 21 mA in high sensitivity mode and 17-18 mA in low power mode
- Low power transmitter 11 - 40 mA during transmit
- Extended supply voltage range 2.3V - 3.6V
- Internal power-on-reset
- 32 bit RX/TX data FIFO
- Programmable Cyclic Redundancy Check (CRC-CCITT, CRC-16, CRC-32)
- Optional spectral shaping using a self synchronizing shift register
- Brown-out detection
- Integrated RX/TX switching
- Differential antenna pins

### 1.2. Applications

400-470 MHz and 800-930 MHz data transmission and reception in the Short Range Devices (SRD) band.

- Telemetric applications, sensor readout
- Toys
- Wireless audio
- Wireless networks
- Wireless USB
- Access control
- Remote keyless entry
- ARIB compatible
- Pointing devices and keyboards
- Active RFID
- RFID base station transmitter
- 433/868/915 MHz SRD band systems

## 2. Block Diagram

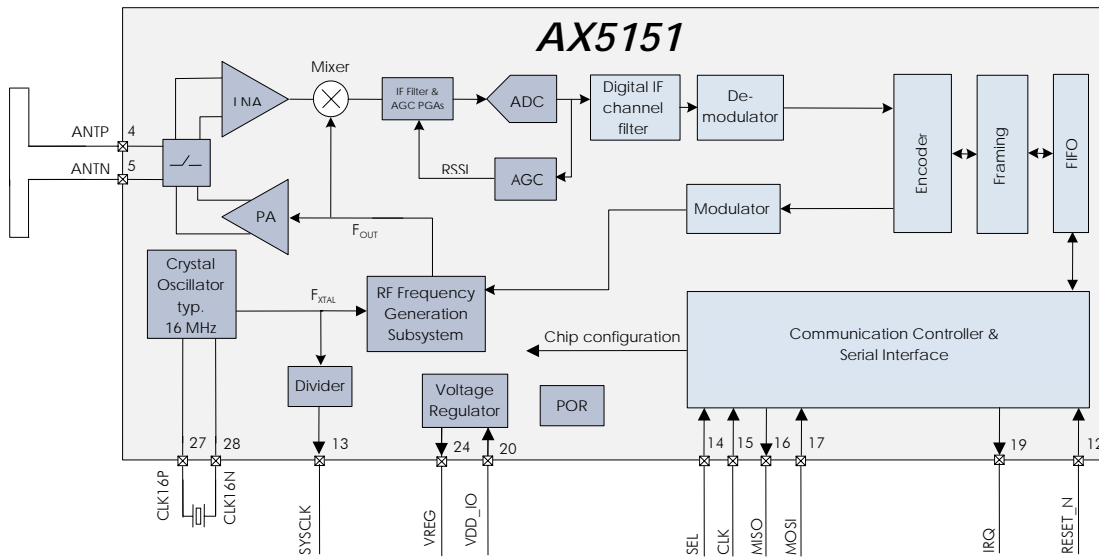

Figure 1 Functional block diagram of the AX5151

### 3. Pin Function Descriptions

Symbol	Pin(s)	Type	Description
VDD	1	N	NC
CLK16P	2	A	Crystal oscillator input/output
CLK16N	3	A	Crystal oscillator input/output
GND	4	P	Ground
VDD	5	P	Power supply, must be supplied with regulated voltage VREG
GND	6	P	Ground
ANTP	7	A	Antenna input/output
ANTN	8	A	Antenna input/output
GND	9	P	Ground
VDD	10	P	Power supply, must be supplied with regulated voltage VREG
GND	11	P	Ground
GND	12	P	Ground
RESET_N	13	I	Optional reset pin If this pin is not used it must be connected to VDD_IO
SYSCLK	14	I/O	Default functionality: Crystal oscillator (or divided) clock output Can be programmed to be used as a general purpose I/O pin
SEL	15	I	Serial peripheral interface select
CLK	16	I	Serial peripheral interface clock
MISO	17	O	Serial peripheral interface data output
MOSI	18	I	Serial peripheral interface data input
TST3	19	I	Must be connected to GND
IRQ	20	I/O	Default functionality: Transmit and receive interrupt Can be programmed to be used as a general purpose I/O pin
VDD_IO	21	P	Unregulated power supply
GND	22	P	Ground
GND	23	P	Ground
VREG	24	P	Regulated output voltage VDD pins must be connected to this supply voltage A 1µF low ESR capacitor to GND must be connected to this pin

A = analog signal  
I = digital input signal  
O = digital output signal

I/O = digital input/output signal  
N = not to be connected  
P = power or ground

All digital inputs are Schmitt trigger inputs, digital input and output levels are LVCMOS/LVTTL compatible and 5V tolerant.



### 3.1. Pinout Drawing

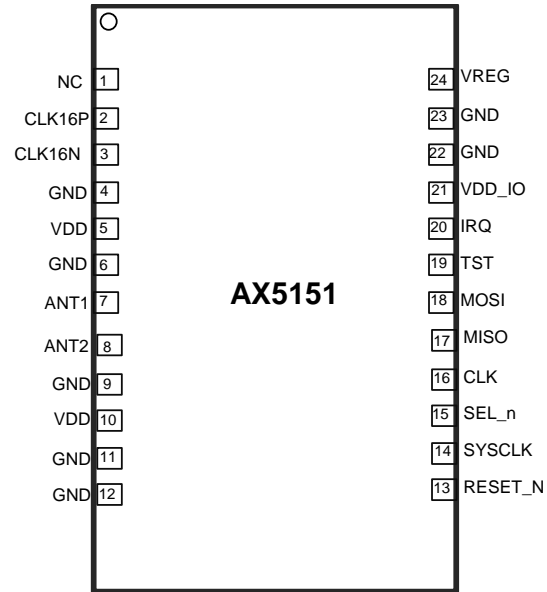

Figure 2: Pinout drawing (Top view)

## 4. Specifications

### 4.1. Absolute Maximum Ratings

Stresses above those listed under Absolute Maximum Ratings may cause permanent damage to the device.

This is a stress rating only; functional operation of the device at these or any other conditions above those listed in the operational sections of this specification is not implied.

Exposure to absolute maximum rating conditions for extended periods may affect device reliability.

SYMBOL	DESCRIPTION	CONDITION	MIN	MAX	UNIT
VDD_IO	Supply voltage		-0.5	5.5	V
IDD	Supply current			100	mA
P <sub>tot</sub>	Total power consumption			800	mW
P <sub>i</sub>	Absolute maximum input power at receiver input			15	dBm
I <sub>i1</sub>	DC current into any pin except ANTP, ANTN		-10	10	mA
I <sub>i2</sub>	DC current into pins ANTP, ANTN		-100	100	mA
I <sub>o</sub>	Output Current			40	mA
V <sub>ia</sub>	Input voltage ANTP, ANTN pins		-0.5	5.5	V
	Input voltage digital pins		-0.5	5.5	V
V <sub>es</sub>	Electrostatic handling	HBM	-2000	2000	V
T <sub>amb</sub>	Operating temperature		-20	70	°C
T <sub>stg</sub>	Storage temperature		-65	150	°C
T <sub>j</sub>	Junction Temperature			150	°C

## 4.2. DC Characteristics

### Supplies

SYMBOL	DESCRIPTION	CONDITION	MIN.	TYP.	MAX.	UNIT
T <sub>AMB</sub>	Operational ambient temperature		-20	27	70	°C
VDD_IO	I/O and voltage regulator supply voltage	RX operation or TX operation up to 4 dBm output power	2.3	3.0	3.6	V
		TX operation up to 12 dBm output power	2.4	3.0	3.6	V
VREG	Internally regulated supply voltage	Power-down mode PWRMODE=0x00		1.7		V
		All other power modes	2.1	2.5	2.8	V
VREG <sub>droptyp</sub>	Regulator voltage drop	RX operation or TX operation up to 4 dBm output power			50	mV
VREG <sub>dropmax</sub>	Regulator voltage drop at maximum internal current consumption	TX mode with 12 dBm output power			300	mV
I <sub>PDOWN</sub>	Power-down current	PWRMODE=0x00		0.5		μA
I <sub>RX-HS</sub>	Current consumption RX  High sensitivity mode: VCO_I=001; REF_I=011	868 MHz, bit rate 10 kbit/s		20		mA
		868 MHz, bit rate 600 kbit/s		21		
		433 MHz, bit rate 10 kbit/s		20		
		433 MHz, bit rate 600 kbit/s		21		
I <sub>RX-LP</sub>	Current consumption RX  Low power mode: VCO_I=001; REF_I=101	868 MHz, bit rate 10 kbit/s		17		mA
		868 MHz, bit rate 600 kbit/s		18		
		433 MHz, bit rate 10 kbit/s		17		
		433 MHz, bit rate 600 kbit/s		18		
I <sub>TX</sub>	Current consumption TX VCO_I=001; REF_I=011; LOCURST=1	868 MHz, 10 dBm		36		mA
		868 MHz, 4 dBm		23		
		868 MHz, 0 dBm		18		
		868 MHz, -12 dBm		11		
		433 MHz, 12 dBm		36		
		433 MHz, 6dBm		23		
		433 MHz, 2 dBm		19		
		433 MHz, -8 dBm		12		

## Logic

---

SYMBOL	DESCRIPTION	CONDITION	MIN.	TYP.	MAX.	UNIT
<b>DIGITAL INPUTS</b>						
$V_{T+}$	Schmitt trigger low to high threshold point			1.9		V
$V_{T-}$	Schmitt trigger high to low threshold point			1.2		V
$V_{IL}$	Input voltage, low				0.8	V
$V_{IH}$	Input voltage, high		2.0			V
$I_L$	Input leakage current		-10		10	$\mu$ A
<b>DIGITAL OUTPUTS</b>						
$I_{OH}$	Output Current, high	$V_{OH} = 2.4V$	4			mA
$I_{OL}$	Output Current, low	$V_{OL} = 0.4V$	4			mA
$I_{OZ}$	Tri-state output leakage current		-10		10	$\mu$ A

### 4.3. AC Characteristics

#### Crystal Oscillator

SYMBOL	DESCRIPTION	CONDITION	MIN.	TYP.	MAX.	UNIT
$f_{XTAL}$	Crystal frequency	Note 1		16		MHz
$g_{m_{osc}}$	Transconductance oscillator	XTALOSCGM=0000		1		mS
		XTALOSCGM=0001		2		
		XTALOSCGM =0010 default		3		
		XTALOSCGM =0011		4		
		XTALOSCGM =0100		5		
		XTALOSCGM =0101		6		
		XTALOSCGM =0110		6.5		
		XTALOSCGM =0111		7		
		XTALOSCGM =1000		7.5		
		XTALOSCGM =1001		8		
		XTALOSCGM =1010		8.5		
		XTALOSCGM =1011		9		
		XTALOSCGM =1100		9.5		
		XTALOSCGM =1101		10		
XTALOSCGM =1110		10.5				
XTALOSCGM =1111		11				
$C_{osc}$	Programmable tuning capacitors at pins CLK16N and CLK16P	XTALCAP = 000000 default		2		pF
		XTALCAP = 111111		33		pF
$C_{osc-lsb}$	Programmable tuning capacitors, increment per LSB of XTALCAP			0.5		pF
$f_{ext}$	External clock input	Note 2		16		MHz
$R_{IN_{osc}}$	Input DC impedance		10			k $\Omega$

#### Notes

1. Tolerances and start-up times depend on the crystal used. Depending on the RF frequency and channel spacing the IC must be calibrated to the exact crystal frequency using the readings of the register TRKFREQ
2. If an external clock is used, it should be input via an AC coupling at pin CLK16P with the oscillator powered up and XTALCAP=000000

## RF Frequency Generation Subsystem (Synthesizer)

SYMBOL	DESCRIPTION	CONDITION	MIN.	TYP.	MAX.	UNIT
$f_{REF}$	Reference frequency			16		MHz
$f_{range\_hi}$	Frequency range	BANDESEL=0	800		930	MHz
$f_{range\_low}$		BANDESEL=1	400		470	
$f_{RESO}$	Frequency resolution		1			Hz
$BW_1$	Synthesizer loop bandwidth VCO current: VCOI=001	Loop filter configuration: FLT=01 Charge pump current: PLLCPI=010		100		kHz
$BW_2$		Loop filter configuration: FLT=01 Charge pump current: PLLCPI=001		50		
$BW_3$		Loop filter configuration: FLT=11 Charge pump current: PLLCPI=010		200		
$BW_4$		Loop filter configuration: FLT=10 Charge pump current: PLLCPI=010		500		
$T_{set1}$	Synthesizer settling time for 1MHz step as typically required for RX/TX switching VCO current: VCO_I=001	Loop filter configuration: FLT=01 Charge pump current: PLLCPI=010		15		$\mu$ s
$T_{set2}$		Loop filter configuration: FLT=01 Charge pump current: PLLCPI=001		30		
$T_{set3}$		Loop filter configuration: FLT=11 Charge pump current: PLLCPI=010		7		
$T_{set4}$		Loop filter configuration: FLT=10 Charge pump current: PLLCPI=010		3		
$T_{start1}$	Synthesizer start-up time if crystal oscillator and reference are running VCO current: VCO_I=001	Loop filter configuration: FLT=01 Charge pump current: PLLCPI=010		25		$\mu$ s
$T_{start2}$		Loop filter configuration: FLT=01 Charge pump current: PLLCPI=001		50		
$T_{start3}$		Loop filter configuration: FLT=11 Charge pump current: PLLCPI=010		12		
$T_{start4}$		Loop filter configuration: FLT=10 Charge pump current: PLLCPI=010		5		
PN868 <sub>1</sub>	Synthesizer phase noise Loop filter configuration: FLT=01	868 MHz, 50 kHz from carrier		-85		dBc/Hz
		868 MHz, 100 kHz from carrier		-90		
		868 MHz, 300 kHz from carrier		-100		
		868 MHz, 2 MHz from carrier		-110		
PN433 <sub>1</sub>	Charge pump current: PLLCPI=010 VCO current: VCO_I=001	433 MHz, 50 kHz from carrier		-90		
		433 MHz, 100 kHz from carrier		-95		
		433 MHz, 300 kHz from carrier		-105		
		433 MHz, 2 MHz from carrier		-115		
PN868 <sub>2</sub>	Synthesizer phase noise Loop filter configuration: FLT=01	868 MHz, 50 kHz from carrier		-80		dBc/Hz
		868 MHz, 100 kHz from carrier		-90		
		868 MHz, 300 kHz from carrier		-105		
		868 MHz, 2 MHz from carrier		-115		
PN433 <sub>2</sub>	Charge pump current: PLLCPI=001 VCO current: VCO_I=001	433 MHz, 50 kHz from carrier		-90		
		433 MHz, 100 kHz from carrier		-95		
		433 MHz, 300 kHz from carrier		-110		
		433 MHz, 2 MHz from carrier		-122		

## Transmitter

SYMBOL	DESCRIPTION	CONDITION	MIN.	TYP.	MAX.	UNIT
SBR	Signal bit rate	ASK & PSK	38.4		600	kbps
		FSK	38.4		200	
PTX <sub>868</sub>	Transmitter power @ 868 MHz LOCURST=1	TXRNG=0000			-40	dBm
		TXRNG=0001		-9.5		
		TXRNG=0010		-4		
		TXRNG=0011		-0.5		
		TXRNG=0100		1.5		
		TXRNG=0101		3.5		
		TXRNG=0110		4.5		
		TXRNG=0111		5.5		
		TXRNG=1000		6.5		
		TXRNG=1001		7.5		
		TXRNG=1010		8		
		TXRNG=1011		8.5		
		TXRNG=1100		9		
		TXRNG=1101		9.5		
		TXRNG=1110		10		
TXRNG=1111		10.5				
PTX <sub>433</sub>	Transmitter power @ 433 MHz	TXRNG=1111		11		dBm
PTX <sub>868-harm2</sub>	Emission @ 2 <sup>nd</sup> harmonic	Note 1		-50		dBc
PTX <sub>868-harm3</sub>	Emission @ 3 <sup>rd</sup> harmonic			-55		

## Notes

1. Additional low-pass filtering was applied to the antenna interface, see section 7: Application Information.

## Receiver

SYMBOL	DESCRIPTION	CONDITION	MIN.	TYP.	MAX.	UNIT
SBR	Signal bit rate	ASK & PSK	38.4		600	kbps
		FSK	38.4		200	
IS <sub>868_HS</sub>	Input sensitivity at BER = 10 <sup>-3</sup> for 868 MHz operation  High sensitivity mode: VCO_I=001; REF_I=011; RXIMIX=01  note 6	ASK 38.4 kbps		-101		dBm
		ASK 50 kbps		-100		
		ASK 100kbps		-98		
		ASK 200 kbps		-95		
		FSK 38.4 kbps		-102		
		FSK 50 kbps		-101		
		FSK 100kbps		-99		
		FSK 200kbps		-97		
		PSK 200 kbps		-98		
		PSK 400 kbps		-95		
		PSK 600 kbps		-93		
IS <sub>868_LS</sub>	Input sensitivity at BER = 10 <sup>-3</sup> for 868 MHz operation  Low power mode: VCO_I=001; REF_I=101; RXIMIX=01  note 6	ASK 38.4 kbps		-99		dBm
		ASK 50 kbps		-98		
		ASK 100kbps		-96		
		ASK 200 kbps		-93		
		FSK 38.4 kbps		-100		
		FSK 50 kbps		-99		
		FSK 100kbps		-97		
		FSK 200kbps		-93		
		PSK 200 kbps		-96		
		PSK 400 kbps		-93		
		PSK 600 kbps		-91		
IL	Maximum input level				-20	dBm
CP <sub>1dB</sub>	Input referred compression point	2 tones separated by 100 kHz		-35		dBm
IIP3	Input referred IP3			-25		
RSSIR	RSSI control range			85		dB
RSSIS <sub>1</sub>	RSSI step size	Before digital channel filter; calculated from register AGCCOUNTER		0.625		dB
RSSIS <sub>2</sub>	RSSI step size	Behind digital channel filter; calculated from registers AGCCOUNTER, TRKAMPL		0.1		dB



SYMBOL	DESCRIPTION	CONDITION	MIN.	TYP.	MAX.	UNIT
SEL <sub>868</sub>	Adjacent channel suppression	FSK 50 kbps, notes 1 & 2		18		dB
	Alternate channel suppression			19		
	Adjacent channel suppression	FSK 100 kbps, notes 1 & 3		16		dB
	Alternate channel suppression			30		
	Adjacent channel suppression	PSK 200 kbps, notes 1 & 4		17		dB
	Alternate channel suppression			28		
BLK <sub>868</sub>	Blocking at +/- 1MHz offset	FSK 100 kbps, note 5		38		dB
	Blocking at - 2MHz offset			40		
	Blocking at +/- 10MHz offset			60		
	Blocking at +/- 100MHz offset			82		
IMRR <sub>868</sub>	Image rejection			30		

## Notes

1. Interferer/Channel @ BER =  $10^{-3}$ , channel level is +10dB above the typical sensitivity, the interfering signal is a random data signal (except PSK200): both channel and interferer are modulated without shaping
2. FSK 50 kbps: 868 MHz, 200 kHz channel spacing, 25 kHz deviation, programming as recommended in Programming Manual
3. FSK 100 kbps: 868 MHz, 400kHz channel spacing, 50 kHz deviation, programming as recommended in Programming Manual
4. PSK 200 kbps: 868 MHz, 400kHz channel spacing, programming as recommended in Programming Manual, interfering signal is a constant wave
5. Channel/Blocker @ BER =  $10^{-3}$ , channel level is +10dB above the typical sensitivity, the blocker signal is a constant wave; channel signal is modulated without shaping, the image frequency lies 2 MHz above the wanted signal
6. Sensitivities for the 433 MHz band are 1-2 dB better than those for the 868 MHz band

## SPI Timing

---

SYMBOL	DESCRIPTION	CONDITION	MIN.	TYP.	MAX.	UNIT
Tss	SEL falling edge to CLK rising edge		10			ns
Tsh	CLK falling edge to SEL rising edge		10			ns
Tssd	SEL falling edge to MISO driving		0		10	ns
Tssz	SEL rising edge to MISO high-Z		0		10	ns
Ts	MOSI setup time		10			ns
Th	MOSI hold time		10			ns
Tco	CLK falling edge to MISO output				10	ns
Tck	CLK period	Note 1	50			ns
Tcl	CLK low duration		40			ns
Tch	CLK high duration		40			ns

### Notes

1. For SPI access during power-down mode the period should be relaxed to 100ns.

For a figure showing the SPI timing parameters see section 5.15: Serial Peripheral Interface (SPI).

## 5. Circuit Description

The **AX5151** is a true single chip low-power CMOS transceiver primarily for use in SRD bands. The on-chip transceiver consists of a fully integrated RF front-end with modulator, and demodulator. Base band data processing is implemented in an advanced and flexible communication controller that enables user friendly communication via the SPI interface.

**AX5151** can be operated from a 2.3 V to 3.6 V power supply over a temperature range of -20°C to 70°C, it consumes 11 - 40 mA for transmitting, depending on the output power, 20 - 21 mA for receiving in high sensitivity mode and 17 - 18 mA for receiving in low power mode.

The **AX5151** features make it an ideal interface for integration into various battery powered SRD solutions such as ticketing or as transceiver for telemetric applications e.g. in sensors. As primary application, the transceiver is intended for UHF radio equipment in accordance with the European Telecommunication Standard Institute (ETSI) specification EN 300 220-1 and the US Federal Communications Commission (FCC) standard CFR47, part 15. The use of **AX5151** in accordance to FCC Par 15.247, allows for improved range in the 915 MHz band. Additionally **AX5151** is compatible with the low frequency standards of 802.15.4 (ZigBee).

The **AX5151** sends and receives data via the SPI port in frames. This standard operation mode is called Frame Mode. Pre and post ambles as well as checksums can be generated automatically. Interrupts control the data flow between a controller and the **AX5151**.

The **AX5151** behaves as a SPI slave interface. Configuration of the **AX5151** is also done via the SPI interface.

**AX5151** supports any data rate from 38.4 kbps to 200 kbps for FSK and MSK and from 38.4 kbps to 600 kbps for ASK and PSK. To achieve optimum performance for specific data rates and modulation schemes several register settings to configure the **AX5151** are necessary, they are outlined in the following, for details see the **AX5151** Programming Manual.

Spreading and despreading is possible on all data rates and modulation schemes. The net transfer rate is reduced by a factor of 15 in this case. For ZigBee either 600 or 300 kbps modes have to be chosen.

The receiver supports multi-channel operation for all data rates and modulation schemes.

## 5.1. Voltage Regulator

The **AX5151** uses an on-chip voltage regulator to create a stable supply voltage for the internal circuitry at pin VREG from the primary supply VDD\_IO. All VDD pins of the device must be connected to VREG. The antenna pins ANTP and ANTEN must be DC biased to VREG. The I/O level of the digital pins is VDD\_IO.

The voltage regulator requires a 1µF low ESR capacitor at pin VREG.

In power-down mode the voltage regulator typically outputs 1.7 V at VREG, if it is powered-up its output rises to typically 2.5 V. At device power-up the regulator is in power-down mode.

The voltage regulator must be powered-up before receive or transmit operations can be initiated. This is handled automatically when programming the device modes via the **PWRMODE** register.

Register **VREG** contains status bits that can be read to check if the regulated voltage is above 1.3 V or 2.3 V, sticky versions of the bits are provided that can be used to detect low power events (brown-out detection).

## 5.2. Crystal Oscillator

The on-chip crystal oscillator allows the use of an inexpensive quartz crystal as the RF generation subsystem's timing reference. Although a wider range of crystal frequencies can be handled by the crystal oscillator circuit, it is recommended to use 16 MHz as reference frequency since this choice allows all the typical SRD band RF frequencies to be generated.

The oscillator circuit is enabled by programming the **PWRMODE** register. At power-up it is not enabled.

To adjust the circuit's characteristics to the quartz crystal being used without using additional external components, both the transconductance and the tuning capacitance of the crystal oscillator can be programmed.

The transconductance is programmed via register bits XTALOSCGM[3:0] in register **XTALOSC**.

The integrated programmable tuning capacitor bank makes it possible to connect the oscillator directly to pins CLK16N and CLK16P without the need for external capacitors. It is programmed using bits XTALCAP[5:0] in register **XTALCAP**.

To synchronize the receiver frequency to a carrier signal, the oscillator frequency could be tuned using the capacitor bank however, the recommended method to implement frequency synchronization is to make use of the high resolution RF frequency generation subsystem together with the Automatic Frequency Control, both are described further down.

Alternatively a single ended reference (TXCO, CXO) may be used. The CMOS levels should be applied to CLK16P via an AC coupling with the crystal oscillator enabled.

### 5.3. SYSCLK Output

The SYSCLK pin outputs the reference clock signal divided by a programmable integer. Divisions from 1 to 2048 are possible. For divider ratios > 1 the duty cycle is 50%. Bits SYSCLK[3:0] in the **PINCFG1** register set the divider ratio. The SYSCLK output can be disabled.

Outputting a frequency that is identical to the IF frequency (default 1 MHz) on the SYSCLK pin is not recommended during receive operation, since it requires extensive decoupling on the PCB to avoid interference.

### 5.4. Power-on-reset (POR) and RESET\_N Input

**AX5151** has an integrated power-on-reset block. No external POR circuit or signal at the RESET\_N pin is required, prior to POR the RESET\_N pin is disabled.

After POR the **AX5151** can be reset in two ways:

1. By SPI accesses: the bit RST in the **PWRMODE** register is toggled.
2. Via the RESET\_N pin: A low pulse is applied at the RESET\_N pin. With the rising edge of RESET\_N the device goes into its operational state.

After POR or reset all registers are set to their default values.

If the RESET\_N pin is not used it must be tied to VDD\_IO.

### 5.5. RF Frequency Generation Subsystem

The RF frequency generation subsystem consists of a fully integrated synthesizer, which multiplies the reference frequency from the crystal oscillator to get the desired RF frequency. The advanced architecture of the synthesizer enables frequency resolutions of 1 Hz, as well as fast settling times of 5 – 50  $\mu$ s depending on the settings (see section 4.3: AC Characteristics). Fast settling times mean fast start-up and fast RX/TX switching, which enables low-power system design.

For receive operation the RF frequency is fed to the mixer, for transmit operation to the power-amplifier.

The frequency must be programmed to the desired carrier frequency. The RF frequency shift by the IF frequency that is required for RX operation, is automatically set when the receiver is activated and does not need to be programmed by the user. The default IF frequency is 1 MHz. It can be programmed to other values. Changing the IF frequency and thus the centre frequency of the digital channel filter can be used to adapt the blocking performance of the device to specific system requirements.

The synthesizer loop bandwidth can be programmed, this serves three purposes:

1. Start-up time optimisation, start-up is faster for higher synthesizer loop bandwidths
2. TX spectrum optimisation, phase-noise at 300 kHz to 1 MHz distance from the carrier improves with lower synthesizer loop bandwidths

- Adaptation of the bandwidth to the data-rate. For transmission of FSK and MSK it is required that the synthesizer bandwidth must be in the order of the data-rate.

## VCO

---

An on-chip VCO converts the control voltage generated by the charge pump and loop filter into an output frequency. This frequency is used for transmit as well as for receive operation. The frequency can be programmed in 1 Hz steps in the **FREQ** registers. For operation in the 433 MHz band, the BANDSEL bit in the **PLLLOOP** register must be programmed.

## VCO Auto-Ranging

---

The **AX5151** has an integrated auto-ranging function, which allows to set the correct VCO range for specific frequency generation subsystem settings automatically. Typically it has to be executed after power-up. The function is initiated by setting the RNG\_START bit in the **PLLRRANGING** register. The bit is readable and a 0 indicates the end of the ranging process. The RNGERR bit indicates the correct execution of the auto-ranging.

## Loop Filter and Charge Pump

---

The **AX5151** internal loop filter configuration together with the charge pump current sets the synthesizer loop band width. The loop-filter has three configurations that can be programmed via the register bits FLT[1:0] in register **PLLLOOP**, the charge pump current can be programmed using register bits PLLCPI[1:0] also in register **PLLLOOP**. Synthesizer bandwidths are typically 50 - 500 kHz depending on the **PLLLOOP** settings, for details see the section 4.3: AC Characteristics.

## Registers

---

Register	Bits	Purpose
PLLLOOP	FLT[1:0]	Synthesizer loop filter bandwidth, recommended usage is to increase the bandwidth for faster settling time, bandwidth increases of factor 2 and 5 are possible.
	PLLCPI[2:0]	Synthesizer charge pump current, recommended usage is to decrease the bandwidth (and improve the phase-noise) for low data-rate transmissions.
	BANDSEL	Switches between 868 MHz/915 MHz and 433 MHz bands
FREQ		Programming of the carrier frequency
IFFREQHI, IFFREQLO		Programming of the IF frequency
PLLRRANGING		Initiate VCO auto-ranging and check results

## 5.6. RF Input and Output Stage (ANTP/ANTN)

The **AX5151** uses fully differential antenna pins. RX/TX switching is handled internally, an external RX/TX switch is not required.

### LNA

---

The LNA amplifies the differential RF signal from the antenna and buffers it to drive the I/Q mixer. An external matching network is used to adapt the antenna impedance to the IC impedance. A DC feed to the regulated supply voltage VREG must be provided at the antenna pins. For recommendations, see section 7: Application Information.

### I/Q Mixer

---

The RF signal from the LNA is mixed down to an IF of typically 1 MHz. I- and Q-IF signals are buffered for the analog IF filter.

### PA

---

In TX mode the PA drives the signal generated by the frequency generation subsystem out to the differential antenna terminals. The output power of the PA is programmed via bits TXRNG[3:0] in the register **TXPWR**. Output power as well as harmonic content will depend on the external impedance seen by the PA, recommendations are given in the section 7: Application Information.

## 5.7. Analog IF Filter

The mixer is followed by a complex band-pass IF filter, which suppresses the down-mixed image while the wanted signal is amplified. The centre frequency of the filter is 1 MHz, with a passband width of 1 MHz. The RF frequency generation subsystem must be programmed in such a way that for all possible modulation schemes the IF frequency spectrum fits into the passband of the analog filter.

## 5.8. Digital IF Channel Filter and Demodulator

The digital IF channel filter and the demodulator extract the data bit-stream from the incoming IF signal. They must be programmed to match the modulation scheme as well as the data-rate. Inaccurate programming will lead to loss of sensitivity.

The channel filter offers bandwidths of 40 kHz up to 600 kHz.

For detailed instructions how to program the digital channel filter and the demodulator see the **AX5151** Programming Manual, an overview of the registers involved is given in the following table. The register setups typically must be done once at power-up of the device.

## Registers

Register	Remarks
CICDEC	This register programs the bandwidth of the digital channel filter.
DATARATEHI, DATARATELO	These registers specify the receiver bit rate, relative to the channel filter bandwidth.
TMGGAINHI, TMGGAINLO	These registers specify the aggressiveness of the receiver bit timing recovery. More aggressive settings allow the receiver to synchronize with shorter preambles, at the expense of more timing jitter and thus a higher bit error rate at a given signal-to-noise ratio.
MODULATION	This register selects the modulation to be used by the transmitter and the receiver, i.e. whether ASK, PSK, FSK, MSK or OQPSK should be used.
PHASEGAIN, FREQGAIN, FREQGAIN2, AMPLGAIN	These registers control the bandwidth of the phase, frequency offset and amplitude tracking loops. Recommended settings are provided in the Programming Manual.
AGCATTACK, AGCDECAY	These registers control the AGC (automatic gain control) loop slopes, and thus the speed of gain adjustments. The faster the bit-rate, the faster the AGC loop should be. Recommended settings are provided in the Programming Manual.
TXRATE	These registers control the bit rate of the transmitter.
FSKDEV	These registers control the frequency deviation of the transmitter in FSK mode. The receiver does not explicitly need to know the frequency deviation, only the channel filter bandwidth has to be set wide enough for the complete modulation to pass.

### 5.9. Encoder

The encoder is located between the Framing Unit, the Demodulator and the Modulator. It can optionally transform the bit-stream in the following ways:

- It can invert the bit stream.
- It can perform differential encoding. This means that a zero is transmitted as no change in the level, and a one is transmitted as a change in the level. Differential encoding is useful for PSK, because PSK transmissions can be received either as transmitted or inverted, due to the uncertainty of the initial phase. Differential encoding / decoding removes this uncertainty.
- It can perform Manchester encoding. Manchester encoding ensures that the modulation has no DC content and enough transitions (changes from 0 to 1 and from 1 to 0) for the demodulator bit timing recovery to function correctly, but does so at a doubling of the data rate.
- It can perform Spectral Shaping. Spectral Shaping removes DC content of the bit stream, ensures transitions for the demodulator bit timing recovery, and makes sure that the transmitted spectrum does not have discrete lines even if the transmitted data is cyclic. It does so without adding additional bits, i.e. without changing the data rate. Spectral Shaping uses a self synchronizing feedback shift register.

The encoder is programmed using the register **ENCODING**, details and recommendations on usage are given in the **AX5151** Programming Manual.



## 5.10. Framing and FIFO

Most radio systems today group data into packets. The framing unit is responsible for converting these packets into a bit-stream suitable for the modulator, and to extract packets from the continuous bit-stream arriving from the demodulator.

The Framing unit supports four different modes:

- HDLC
- Raw
- Raw with Preamble Match
- 802.15.4 compliant

The micro-controller communicates with the framing unit through a 4 level × 10 bit FIFO. The FIFO decouples micro-controller timing from the radio (modulator and demodulator) timing. The bottom 8 bits of the FIFO contain transmit or receive data. The top 2 bit are used to convey meta information in HDLC and 802.15.4 modes. They are unused in Raw and Raw with Preamble Match modes. The meta information consists of packet begin / end information and the result of CRC checks.

The **AX5151** contains one FIFO. Its direction is switched depending on whether transmit or receive mode is selected.

The FIFO can be operated in polled or interrupt driven modes. In polled mode, the micro-controller must periodically read the FIFO status register or the FIFO count register to determine whether the FIFO needs servicing.

In interrupt mode EMPTY, NOT EMPTY, FULL, NOT FULL and programmable level interrupts are provided. The **AX5151** signals interrupts by asserting (driving high) its IRQ line. The interrupt line is level triggered, active high. Interrupts are acknowledged by removing the cause for the interrupt, i.e. by emptying or filling the FIFO.

Basic FIFO status (EMPTY, FULL, Overrun, Underrun, and the top two bits of the top FIFO word) are also provided during each SPI access on MISO while the micro-controller shifts out the register address on MOSI. See the SPI interface section for details. This feature significantly reduces the number of SPI accesses necessary during transmit and receive.

## HDLC Mode

---

**Note:** HDLC mode follows High-Level Data Link Control (HDLC, ISO 13239) protocol.

HDLC Mode is the main framing mode of the **AX5151**. In this mode, the **AX5151** performs automatic packet delimiting, and optional packet correctness check by inserting and checking a cyclic redundancy check (CRC) field.

The packet structure is given in the following table.

Flag	Address	Control	Information	FCS	(Optional Flag)
8 bit	8 bit	8 or 16 bit	Variable length, 0 or more bits in multiples of 8	16 / 32 bit	8 bit

HDLC packets are delimited with flag sequences of content 0x7E.

In **AX5151** the meaning of address and control is user defined. The Frame Check Sequence (FCS) can be programmed to be CRC-CCITT, CRC-16 or CRC-32.

The receiver checks the CRC, the result can be retrieved from the FIFO, the CRC is appended to the received data.

For details on implementing a HDLC communication see the **AX5151** Programming Manual.

## RAW Mode

---

In Raw mode, the **AX5151** does not perform any packet delimiting or byte synchronization. It simply serialises transmit bytes and de-serializes the received bit-stream and groups it into bytes.

This mode is ideal for implementing legacy protocols in software.

## RAW Mode with Preamble Match

---

Raw mode with preamble match is similar to raw mode. In this mode, however, the receiver does not receive anything until it detects a user programmable bit pattern (called the preamble) in the receive bit-stream. When it detects the preamble, it aligns the de-serialization to it.

The preamble can be between 4 and 32 bits long.

## 802.15.4 (ZigBee)

---

802.15.4 uses binary phase shift keying (PSK) with 300 kbit/s (868 MHz band) or 600 kbit/s (915 MHz band) on the radio. The usable bit rate is only a 15<sup>th</sup> of the radio bit rate, however. A spreading function in the transmitter expands the user bit rate by a factor of 15, to make the transmission more robust. The despreader function of the receiver undoes that.

In 802.15.4 mode, the **AX5151** framing unit performs the spreading and despreading function according to the 802.15.4 specification. In receive mode, the framing unit will also automatically search for the 802.15.4 preamble, meaning that no interrupts will have to be serviced by the micro-controller until a packet start is detected.

### 5.11. RX AGC and RSSI

**AX5151** features two receiver signal strength indicators (RSSI):

1. RSSI before the digital IF channel filter.  
The gain of the receiver is adjusted in order to keep the analog IF filter output level inside the working range of the ADC and demodulator. The register **AGCCOUNTER** contains the current value of the AGC and can be used as an RSSI. The step size of this RSSI is 0.625 dB. The value can be used as soon as the RF frequency generation sub-system has been programmed.
2. RSSI behind the digital IF channel filter.  
The demodulator also provides amplitude information in the **TRK\_AMPLITUDE** register. By combining both the **AGCCOUNTER** and the **TRK\_AMPLITUDE** registers, a high resolution (better than 0.1dB) RSSI value can be computed at the expense of a few arithmetic operations on the micro-controller. Formulas for this computation can be found in the **AX5151** Programming Manual.

## 5.12. Modulator

Depending on the transmitter settings the modulator generates various inputs for the PA:

Modulation	Bit = 0	Bit = 1	Main Lobe Bandwidth	Max. Bitrate
ASK	PA off	PA on	BW=BITRATE	600kBit/s
FSK / MSK	$\Delta f = -f_{\text{deviation}}$	$\Delta f = +f_{\text{deviation}}$	$BW = (1+h) \cdot \text{BITRATE}$	200kBit/s
PSK	$\Delta \Phi = 0^\circ$	$\Delta \Phi = 180^\circ$	BW=BITRATE	600kBit/s

$h$  = modulation index. It is the ratio of the deviation compared to the bit-rate;  $f_{\text{deviation}} = 0.5 \cdot h \cdot \text{BITRATE}$ , **AX5151** can demodulate signals with  $h < 32$ .

ASK = amplitude shift keying

FSK = frequency shift keying

MSK = minimum shift keying; MSK is a special case of FSK, where  $h = 0.5$ , and therefore  $f_{\text{deviation}} = 0.25 \cdot \text{BITRATE}$ ; the advantage of MSK over FSK is that it can be demodulated more robustly.

PSK = phase shift keying

OQPSK = offset quadrature shift keying. The **AX5151** supports OQPSK. However, unless compatibility to an existing system is required, MSK should be preferred.

All modulation schemes are binary.

## 5.13. Automatic Frequency Control (AFC)

The **AX5151** has a frequency tracking register **TRKFREQ** to synchronize the receiver frequency to a carrier signal. For AFC adjustment, the frequency offset can be computed with the following formula:

$$\Delta f = \frac{\text{TRKFREQ}}{2^{16}} \text{BITRATE} \times \text{FSKMUL}.$$

FSKMUL is the FSK oversampling factor, it depends on the FSK bit rate and deviation used. To determine it for a specific case, see the **AX5151** Programming Manual. For modulations other than FSK, FSKMUL=1.

### 5.14. PWRMODE Register

The *PWRMODE* register controls, which parts of the chip are operating.

<i>PWRMODE</i> register	Name	Description	Typical I <sub>dd</sub>
0000	POWERDOWN	All digital and analog functions, except the register file, are disabled. The core supply voltage is reduced to conserve leakage power. SPI registers are still accessible, but at a slower speed.	0.5 $\mu$ A
0100	VREGON	All digital and analog functions, except the register file, are disabled. The core voltage, however is at its nominal value for operation, and all SPI registers are accessible at the maximum speed.	200 $\mu$ A
0101	STANDBY	The crystal oscillator is powered on; receiver and transmitter are off.	650 $\mu$ A
1000	SYNTHR <sub>X</sub>	The synthesizer is running on the receive frequency. Transmitter and receiver are still off. This mode is used to let the synthesizer settle on the correct frequency for receive.	11 mA
1001	FULLR <sub>X</sub>	Synthesizer and receiver are running.	17 - 20 mA
1100	SYNHT <sub>X</sub>	The synthesizer is running on the transmit frequency. Transmitter and receiver are still off. This mode is used to let the synthesizer settle on the correct frequency for transmit.	10 mA
1101	FULLT <sub>X</sub>	Synthesizer and transmitter are running. Do not switch into this mode before the synthesizer has completely settled on the transmit frequency (in SYNHT <sub>X</sub> mode), otherwise spurious spectral transmissions will occur.	11 - 40 mA

A typical *PWRMODE* sequence for a transmit session :

Step	PWRMODE	Remarks
1	POWERDOWN	
2	STANDBY	The settling time is dominated by the crystal used, typical value 3ms.
3	SYNTHTX	The synthesizer settling time is 5 – 50 $\mu$ s depending on settings, see section AC Characteristics
4	FULLTX	Data transmission
5	SYNTHTX	<b>This step must be programmed after FULLTX mode, or the device will not enter POWERDOWN or STANDBY mode.</b>
6	POWERDOWN	

A typical *PWRMODE* sequence for a receive session :

Step	PWRMODE[3:0]	Remarks
1	POWERDOWN	
2	STANDBY	The settling time is dominated by the crystal used, typical value 3ms
3	SYNTHRX	The synthesizer settling time is 5 – 50 $\mu$ s depending on settings, see section AC Characteristics
4	FULLRX	Data reception
5	POWERDOWN	

## 5.15. Serial Peripheral Interface (SPI)

The **AX5151** can be programmed via a four wire serial interface according SPI using the pins CLK, MOSI, MISO and SEL. Registers for setting up the **AX5151** are programmed via the serial peripheral interface in all device modes.

When the interface signal SEL is pulled low, a 16 bit configuration data stream is expected on the input signal pin MOSI, which is interpreted as D0...D7, A0...A6, R\_N/W.

Data read from the interface appears on MISO.

Figure 3 shows a write/read access to the interface. The data stream is built of an address byte including read/write information and a data byte. Depending on the R\_N/W bit and address bits A[6..0], data D[7..0] can be written via MOSI or read at the pin MISO.

R\_N/W = 0 means read mode, R\_N/W = 1 means write mode.

The read sequence starts with 7 bits of status information S[6..0] followed by 8 data bits.

The status bits contain the following information:

S6	S5	S4	S3	S2	S1	S0
PLL LOCK	FIFO OVER	FIFO UNDER	FIFO FULL	FIFO EMPTY	FIFOSTAT(1)	FIFOSTAT(0)

### SPI Timing

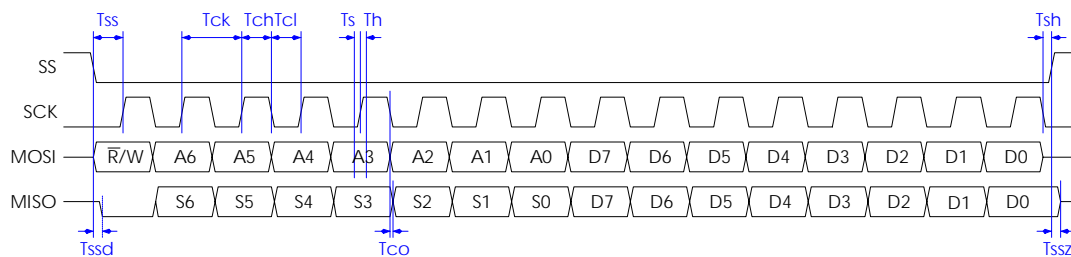

Figure 3 Serial peripheral interface timing

## 6. Register Bank Description

This section describes the bits of the register bank in detail. The registers are grouped by functional block to facilitate programming.

No checks are made whether the programmed combination of bits makes sense! Bit 0 is always the LSB.

**Note** Whole registers or register bits marked as reserved should be kept at their default values.

**Note** All addresses not documented here must not be accessed, neither in reading nor in writing.



## 6.1. Control Register Map

Addr	Name	Dir	Reset	Bit								Description
				7	6	5	4	3	2	1	0	
<b>Revision &amp; Interface Probing</b>												
0	<i>REVISION</i>	R	00010100	SILICONREV(7:0)								Silicon Revision
1	<i>SCRATCH</i>	RW	11000101	SCRATCH(7:0)								Scratch Register
<b>Operating Mode</b>												
2	<i>PWRMODE</i>	RW	0---0000	RST	-	-	-	PWRMODE(3:0)			Power Mode	
<b>Crystal Oscillator, Part 1</b>												
3	<i>XTALOSC</i>	RW	----0010	-	-	-	-	XTALOSCGM(3:0)			GM of Crystal Oscillator	
<b>FIFO, Part 1</b>												
4	<i>FIFOCTRL</i>	RW	-----11	FIFOSTAT(1:0)		FIFO OVER	FIFO UNDER	FIFO FULL	FIFO EMPTY	FIFOCMD(1:0)	FIFO Control	
5	<i>FIFODATA</i>	RW	-----	FIFODATA(7:0)								FIFO Data
<b>Interrupt Control</b>												
6	<i>IRQMASK</i>	RW	--000000	-	-	IRQMASK(5:0)					IRQ Mask	
7	<i>IRQREQUEST</i>	R	-----	-	-	IRQREQUEST(5:0)					IRQ Request	
<b>Interface &amp; Pin Control</b>												
8	<i>IFMODE</i>	RW	----0011	-	-	-	-	IFMODE(3:0)			Interface Mode <b>Must be set to 0000</b>	
0C	<i>PINCFG1</i>	RW	11111000	reserved		IRQZ	reserved	SYSCLK(3:0)			Pin Configuration 1	
0D	<i>PINCFG2</i>	RW	00000000	TST_PINS		IRQE	reserved	reserved	IRQI	reserved	Pin Configuration 2 <b>TST_PINS(1:0) must be set to 11</b>	



0E	<i>PINCFG3</i>	R	-----	-	-	-	SYSCLKR	reserved	IRQR	reserved	Pin Configuration 3	
0F	<i>IRQINVERSION</i>	RW	--000000	-	-	IRQINVERSION(5:0)				IRQ Inversion		
<b>Modulation &amp; Framing</b>												
10	<i>MODULATION</i>	RW	-0000010	-	MODULATION(6:0)						Modulation	
11	<i>ENCODING</i>	RW	---0010	-	-	-	ENC MANCH	ENC SCRAM	ENC DIFF	ENC INV	Encoder/Decoder Settings	
12	<i>FRAMING</i>	RW	-0000000	FRMRX	HSUPP	CRCMODE(1:0)	FRMMODE(2:0)		FABORT	FRAMING	Framing settings	
14	<i>CRCINIT3</i>	RW	11111111	CRCINIT(31:24)						CRC Initialization Data or Preamble		
15	<i>CRCINIT2</i>	RW	11111111	CRCINIT(23:16)						CRC Initialization Data or Preamble		
16	<i>CRCINIT1</i>	RW	11111111	CRCINIT(15:8)						CRC Initialization Data or Preamble		
17	<i>CRCINIT0</i>	RW	11111111	CRCINIT(7:0)						CRC Initialization Data or Preamble		
<b>Voltage Regulator</b>												
1B	<i>VREG</i>	R	-----	-	-	-	-	SSDS	SSREG	SDS	SREG	Voltage Regulator Status
<b>Synthesizer</b>												
20	<i>FREQ3</i>	RW	00111001	FREQ(31:24)						Synthesizer Frequency		
21	<i>FREQ2</i>	RW	00110100	FREQ(23:16)						Synthesizer Frequency		
22	<i>FREQ1</i>	RW	11001100	FREQ(15:8)						Synthesizer Frequency		
23	<i>FREQ0</i>	RW	11001101	FREQ(7:0)						Synthesizer Frequency		
25	<i>FSKDEV2</i>	RW	00000010	FSKDEV(23:16)						FSK Frequency Deviation		
26	<i>FSKDEV1</i>	RW	01100110	FSKDEV(15:8)						FSK Frequency Deviation		
27	<i>FSKDEV0</i>	RW	01100110	FSKDEV(7:0)						FSK Frequency Deviation		
28	<i>IFFREQHI</i>	RW	00100000	IFFREQ(15:8)						2nd LO / IF Frequency		
29	<i>IFFREQLO</i>	RW	00000000	IFFREQ(7:0)						2nd LO / IF Frequency		
2C	<i>PLLLOOP</i>	RW	-0011101	-	reserved	BANDSEL	PLLCPI(2:0)		FLT(1:0)	PLLLOOP	Synthesizer Loop Filter Settings	
2D	<i>PLLRRANGING</i>	RW	00001000	STICKY LOCK	PLL LOCK	RNGERR	RNG START	VCOR(3:0)		PLLRRANGING	Synthesizer VCO Auto-Ranging	

Transmitter											
30	<i>TXPWR</i>	RW	----1000	-	-	-	-	TXRNG(3:0)		Transmit Power	
31	<i>TXRATEHI</i>	RW	00001001	TXRATE(23:16)							Transmitter Bitrate
32	<i>TXRATEMID</i>	RW	10011001	TXRATE(15:8)							Transmitter Bitrate
33	<i>TXRATELO</i>	RW	10011010	TXRATE(7:0)							Transmitter Bitrate
34	<i>MODMISC</i>	RW	-----11	-	-	-	-	-	reserved	PTCLK GATE Misc RF Flags	
FIFO, Part 2											
35	<i>FIFOCOUNT</i>	R	-----	-	-	-	-	-	FIFOCOUNT(2:0) FIFO Fill state		
36	<i>FIFOTHRESH</i>	RW	-----000	-	-	-	-	-	FIFOTHRESH(2:0) FIFO Threshold		
37	<i>FIFOCONTROL2</i>	RW	0-----00	CLEAR	-	-	-	-	-	STOPONERR(1:0) Additional FIFO control	
Receiver											
3A	<i>AGCATTACK</i>	RW	00010110	-	-	-	AGCATTACK(4:0)			AGC Attack	
3B	<i>AGCDECAY</i>	RW	0-010011	reserved	-	reserved	AGCDECAY(4:0)			AGC Decay	
3C	<i>AGCCOUNTER</i>	R	-----	AGCCOUNTER(7:0)							AGC Current Value
3D	<i>CICSHIFT</i>	R	--000100	-	-	reseved	CICSHIFT(4:0)			CIC Shift Factor	
3F	<i>CICDEC</i>	RW	00000100	-	-	CICDEC(5:0)				CIC Decimation Factor	
40	<i>DATARATEHI</i>	RW	00011010	DATARATE(15:8)							Datarate
41	<i>DATARATELO</i>	RW	10101011	DATARATE(7:0)							Datarate
42	<i>TMGAINHI</i>	RW	00000000	TIMINGGAIN(15:8)							Timing Gain
43	<i>TMGAINLO</i>	RW	11010101	TIMINGGAIN(7:0)							Timing Gain
44	<i>PHASEGAIN</i>	RW	00--0011	reserved	-	-	PHASEGAIN(3:0)			Phase Gain	
45	<i>FREQGAIN</i>	RW	00001010	reserved				FREQGAIN(3:0)			Frequency Gain
46	<i>FREQGAIN2</i>	RW	----1010	-	-	-	-	FREQGAIN2(3:0)			Frequency Gain 2
47	<i>AMPLGAIN</i>	RW	---00110	-	-	-	reserved	AMPLGAIN(3:0)			Amplitude Gain
48	<i>TRKAMPLHI</i>	R	-----	TRKAMPL(15:8)							Amplitude Tracking
49	<i>TRKAMPLLO</i>	R	-----	TRKAMPL(7:0)							Amplitude Tracking
4A	<i>TRKPHASEHI</i>	R	-----	-	-	-	-	TRKPHASE(11:8)			Phase Tracking

4B	<i>TRKPHASELO</i>	R	-----			TRKPHASE(7:0)	Phase Tracking
4C	<i>TRKFREQHI</i>	R	-----			TRKFREQ(15:8)	Frequency Tracking
4D	<i>TRKFREQLO</i>	R	-----			TRKFREQ(7:0)	Frequency Tracking
<b>Crystal Oscillator, Part 2</b>							
4F	<i>XTALCAP</i>	RW	--000000	-	-	XTALCAP(5:0)	Crystal oscillator tuning capacitance
<b>Misc</b>							
72	<i>PLLVCOI</i>	RW	--000100	-	-	reserved	VCO_I[2:0] Synthesizer VCO current <b>Must be set to 001</b>
7A	<i>LOCURST</i>	RW	00110000	LOCURST		reserved	LOCURST <b>Must be set to 1</b>
7C	<i>REF</i>	RW	--100011	-	-	reserved	REF_I[2:0] Reference adjust
7D	<i>RXMISC</i>	RW	--110110	-	-	reserved	RXIMIX(1:0) Misc RF settings <b>RXIMIX(1:0) must be set to 01</b>

## 7. Application Information

### 7.1. Typical Application Diagram

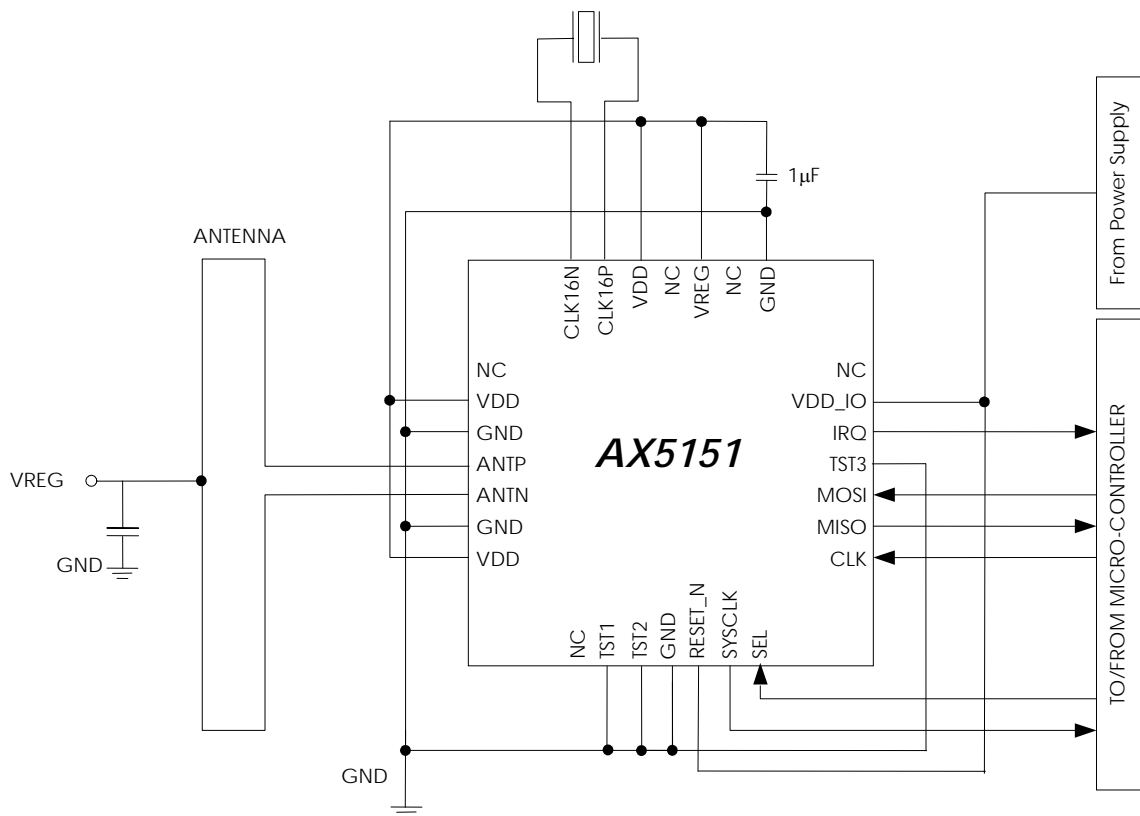

Figure 4 Typical application diagram

It is mandatory to add 1µF (low ESR) between VREG and GND.

Decoupling capacitors are not all drawn. It is recommended to add 100nF decoupling capacitor for every VDD and VDD\_IO pin. In order to reduce noise on the antenna inputs it is recommended to add 27 pF on the VDD pins close to the antenna interface.

## 7.2. Antenna Interface Circuitry

The ANTP and ANTN pins provide RF input to the LNA when **AX5151** is in receive mode, and RF output from the PA when **AX5151** is in transmit mode. A small antenna can be connected with an optional translation network. The network must provide DC power to the PA and LNA. A biasing to VREG is necessary.

Beside biasing and impedance matching, the proposed networks also provide low pass filtering to limit spurious emission.

### Single-Ended Antenna Interface

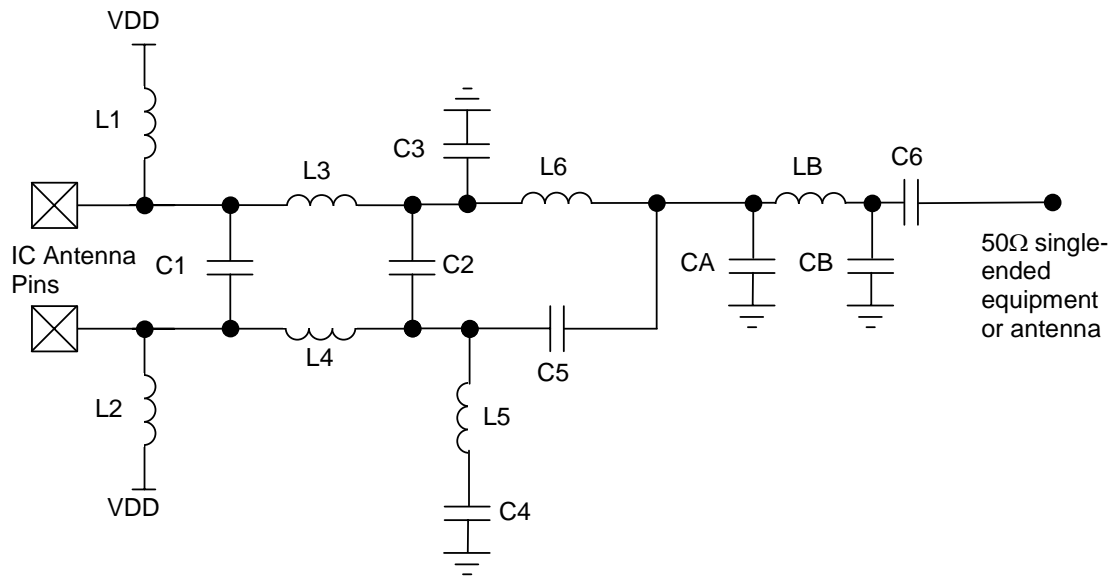

Figure 5 Structure of the antenna interface to 50  $\Omega$  single-ended equipment or antenna

Frequency Band	L1=L2 [nH]	C1 [pF]	L3=L4 [nH]	C2 [pF]	C3=C5 [pF]	L5=L6 [nH]	LB [nH]	CA=CB [pF]	C4=C6 [pF]
868 / 915 MHz	18	2.2	12	2.2	1.8	18	6.2	8.2	220
433 MHz	33	3	33	3.3	3.3	39	12	18	220

## Dipole Antenna Interface

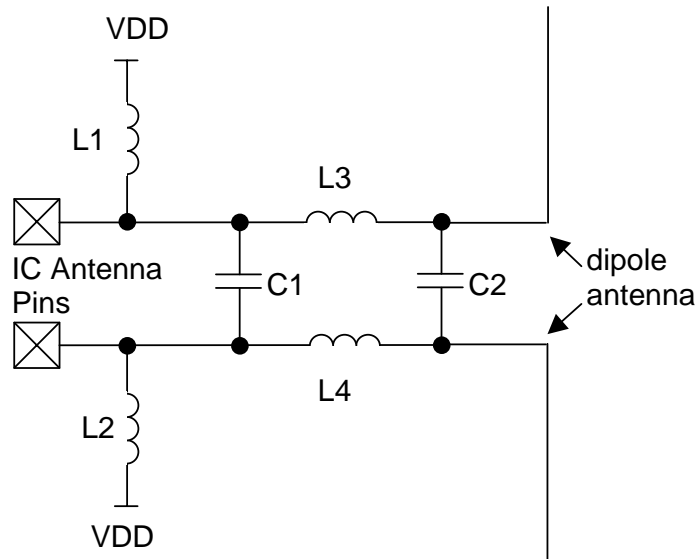

Figure 6 Structure of the antenna interface to a dipole antenna

Frequency Band	L1=L2 [nH]	C1 [pF]	L3=L4 [nH]	C2 [pF]
868 / 915 MHz	18	3.9	6.8	3.3
433 MHz	33	8	15	6.8

### 7.3. Voltage Regulator

The **AX5151** has an integrated voltage regulator which generates a stable supply voltage VREG from the voltage applied at VDD\_IO. Use VREG to supply all the VDD supply pins.

## 8. TSSOP24 Package Information

### 8.1. Package Outline TSSOP24





## 9. Life Support Applications

This product is not designed for use in life support appliances, devices, or in systems where malfunction of this product can reasonably be expected to result in personal injury. AXSEM customers using or selling this product for use in such applications do so at their own risk and agree to fully indemnify AXSEM for any damages resulting from such improper use or sale.

## 10. Contact Information

**AXSEM AG**

Oskar-Bider-Strasse 1  
CH-8600 Dübendorf  
SWITZERLAND

Phone +41 44 882 17 07  
Fax +41 44 882 17 09  
Email [sales@axsem.com](mailto:sales@axsem.com)  
[www.axsem.com](http://www.axsem.com)

For further product related or sales information please visit our website or contact your local representative.

The specifications in this document are subject to change at AXSEM's discretion. AXSEM assumes no responsibility for any claims or damages arising out of the use of this document, or from the use of products based on this document, including but not limited to claims or damages based on infringement of patents, copyrights or other intellectual property rights. AXSEM makes no warranties, either expressed or implied with respect to the information and specifications contained in this document. AXSEM does not support any applications in connection with life support and commercial aircraft. Performance characteristics listed in this document are estimates only and do not constitute a warranty or guarantee of product performance. The copying, distribution and utilization of this document as well as the communication of its contents to others without expressed authorization is prohibited. Offenders will be held liable for the payment of damages. All rights reserved. Copyright © 2007 AXSEM AG