



MEMS Capacitive Accelerometers

Data sheet

MS9000.D

30S.MS9X.H.12.09

Features

Extra small LCC20 packaging (8.9mm x 8.9mm)
±2g to ±200g Full scale range
Excellent Bias stability
Harsh Environment (shock, vibration, temperature)
MIL-STD-833-E qualified
Low power analog voltage output
Brown out protected

Applications

Inertial sensing
 IMU / AHRS for Mil/Aerospace
 Avionics
 UAV
 Land & sea inertial navigation
 Directional drilling
 Geophysics
 Train control
 Tilt & inclination

Description

Colibrys MS9000 inertial accelerometer is a new extra small product designed for harsh environment and safety critical applications. This generation of products comes in a LCC20 (8.9mm x 8.9mm) ceramic package and in a variety of g ranges from ±2g to ±200g. These sensors can operate over extended temperature ranges with just a few milli g bias stability guaranteed over extended lifetime

The Colibrys MS9000 accelerometer is a MEMS capacitive sensor, based upon a bulk micro-machined silicon element, a low power ASIC for signal conditioning, a micro-controller for storage of compensation values and a temperature sensor. The product is low power, calibrated, robust and stable and the electronic configuration provides a solid power on reset and ensures a full protection against brown-out.

MS9000 side view

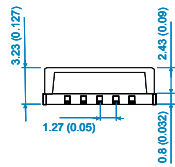

Typ. values mm (inch)

MS9000 bottom view

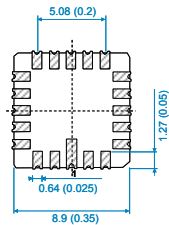

MS9000 side view

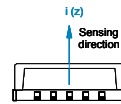

MS9000 top view

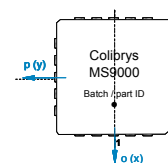

Specifications

All values are specified at +20°C (+68°F) and 5.0 VDC supply voltage, unless otherwise stated

Units	MS9002.D	MS9005.D	MS9010.D	MS9030.D	MS9050.D	MS9100.D	MS9200.D
Full scale range	± 2g	± 5g	± 10g	± 30g	± 50g	± 100g	± 200g
Packaging	LCC20 (non magnetic, 8.9mm x 8.9mm / 0.35inch x 0.35inch)						
Bias calibration	mg	< 10	< 25	< 50	< 150	< 250	< 1000
One year bias stability @ 6000g [1]	mg typ. (max.)	1.5 (<5)	3.75 (<12.5)	7.5 (<25)	22 (<75)	37.5 (<125)	150 (<500)
One year bias stability @ 1000g [2]	mg typ. (max.)	0.3 (<1.5)	0.75 (<3.75)	1.5 (<7.5)	4.5 (<22.5)	7.5 (<37.5)	30 (<150)
Switch on/off repeatability	mg max.	< 0.15	< 0.375	< 0.75	< 1.5	< 3.8	< 15
Bias temp. coefficient [2]	mg/°C typ.	<0.1	<0.25	<0.5	<1.5	<2.5	< 10
	mg/°C max.	± 0.4	± 1	± 2	± 6	± 10	± 40
Scale factor sensitivity (K1)	mV/g	1000 ± 8	400 ± 4	200 ± 2	66.6 ± 1	40 ± 1	20 ± 1
One year scale factor stability [1] & [2]	ppm typ. (max.)	300 (< 1000)	300 (< 1000)	300 (< 1000)	300 (< 1000)	300 (< 1000)	300 (< 1000)
Scale factor temp. coefficient [3]	ppm / °C typ.	100	100	100	100	100	100
	min. / max.	-50 / 250	-50 / 250	-50 / 250	-50 / 250	-50 / 250	-50 / 250
Input axis misalignment (Kp, Ko)	mrad max.	< 10	< 10	< 10	< 10	< 10	< 10
	% max	1	1	1	1	1	1
Resolution / Threshold (@ 1Hz)	mg max.	< 0.1	< 0.25	< 0.6	< 1.7	< 2.8	< 11
Non linearity [5]	% of FS max.	< 0.8	<0.8	< 0.9	< 0.9	< 0.9	< 1
	g max.	< 0.02	<0.04	< 0.09	< 0.27	< 0.50	< 2
Bandwidth [4]	Hz	0 to ≥ 100	0 to ≥ 100	0 to ≥ 100	0 to ≥ 100	0 to ≥ 100	0 to ≥ 100
Noise spectral density in band (0 ; 9kHz)	µV/√Hz typ.	18	18	18	18	18	18
	max.	24	24	24	24	24	24
Resonant frequency	kHz	1.4	2.9	3.7	6.3	11	26

[1]: One year stability defined according to IEEE 528-2001: turn on / on, storage at -55°C and 85°C, -40°C to 125°C T cycling, -55°C to 85°C unpowered harass, vibration, shock (6000g, single shock).

[2]: One year stability defined according to IEEE 528-2001: turn on / on, storage at -55°C and 85°C, -40°C to 125°C T cycling, -55°C to 85°C unpowered harass, vibration, shock (1000g, single shock).

[3]: Temperature coefficients are specified for a range of -40°C to 20°C, where temperature behavior is typically linear.

[4]: The bandwidth is defined as the frequency band for which the sensitivity has decreased by less than 3dB.

[5]: The non linearity specification for 200g version is validated to maximum ±100g range.

Environmental	MS9002.D	MS9005.D	MS9010.D	MS9030.D	MS9050.D	MS9100.D	MS9200.D
Operating temperature range	-55°C to +125°C (-67°F to 255°F)						
Reliability	Results based on MIL-HDBK-217, notice 2, are available on request.						
Shock resistance	Up to 6'000 g (0.15ms half-sine, single shock, not repetitive, in one direction o, p or l)						
Recovery time	< 1ms (1000g, half-sine period 1ms, shocks in direction i)						
Vibration	20 g rms, 20-2000 Hz (random noise, 30 minutes in each direction o, p, i)						
LCC packaging	The product has been qualified according to MIL-STD-883-G. Hermetic sealing is qualified at 5·10 ⁻⁸ atm·cm ² /s						
ESD sensitivity	Class 2 (requirements MIL-STD-883-G, 1 Method 3015.7), HBM 2kV						
Proximity effect	The sensor is sensitive to external parasitic capacitance. Proximity of large metallic mass (typ accelerometer size in mm ranges) must be avoided to insure best performances.						

Note: LCC must be tightly fixed to the PCB, using the bottom of the housing as reference plan for axis alignment.

Electrical	
Input voltage (VDD – VSS)	2.5 to 5.5 VDC. The standard voltage for calibration is 5.0 VDC.
Output voltage range	From 0.5 to 4.5 VDC @ 5.0 VDC input voltage (2.5 V ± 10mV at 0g)
Operating current consumption	< 400 µA @ 5.0 VDC
Initialization & reset current consumption	Typ. 1500 µA @ 5.0 VDC during the initialization phase (less than 35 ms at room temperature)
Reset	The sensor is Brown out protected. A reset occurs when the power supply jumps more than +0.46 V with a slope >380V/s or if the power supply drops below 2.2V. The recovery time is typ. 25 ms (max 35 ms)
Output impedance / load	Min. 50 kΩ at Vout (pin 8) and VAGND (pin 5) Max. 50 pF at Vout (pin 8) and Max. 100 µF at VAGND (pin 5)

Physical	
	Hermetically sealed LCC, 20 pins housing
Weight	< 1.5 grams
Size	Typ. 8.9 x 8.9 x 3.23 mm (0.35 x 0.35 x 0.127 inch) Max. 9.2 x 9.2 x 3.5 mm (0.354 x 0.354 x 0.138 inch)

Temperature sensor	
Output Voltage at 20°C	Typ: 1.632 V
Sensitivity	Typ: -11.77 mV/°C
Long term stability	Max -0.03°C to +0.09°C (1000h @ 150°C)
Accuracy	± 5°C (From -40°C to 125°C)

Block diagram and electrical connections

It is necessary to use decoupling capacitors [C] of 1µF each between VDD and VAGND and between VAGND and VSS,

placed as close as possible from the accelerometer. COG or X7R @ 5% capacitor types are recommended.

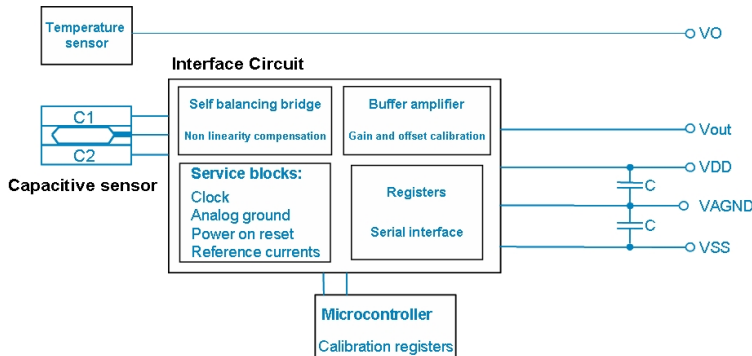

MS9000 top view

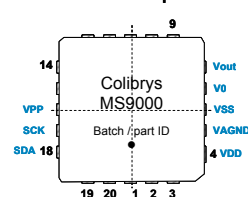

Pin	Description	Remarks
4	VDD	Power supply
5	VAGND	Accelerometer output reference voltage(VDD/2)
6	VSS	Ground
7	VO	Temperature sensor output
8	Vout	Accelerometer output signal
16	VPP (Colibrys internal calibration pin)	Must be connected to VSS
17	SCK (Colibrys internal calibration pin)	Must be connected to VSS
18	SDA (Colibrys internal calibration pin)	Must be connected to VSS

A detailed MS9000 Product Description (30D.MS9X.x.xx) and further Application Notes are available on demand or on our web site.

In order to provide an ideal support to our customers, our

standard MS9000 products will be available worldwide through a wide network of distributors and agents or directly at Colibrys. Do not hesitate to access our web site for precise contacts or contact directly Colibrys in Europe or in US for more details.



Colibrys (Switzerland) Ltd
accelero.europe@colibrys.com



Colibrys, Inc.
accelero.us@colibrys.com

www.colibrys.com

Colibrys reserves the right to change these data without notice.