

# DATA SHEET

# 10 GBPS 850NM PIN + PREAMP LC ROSA PACKAGE

## HFD6X80-419

### FEATURES:

- Low gain, non-inverting
- LC ROSA package  
SC ROSA package.
- High performance GaAs PIN photodiode with separate transimpedance amplifier
- Low electrical parasitic TO46 package
- Data rates up to 10.7Gbps
- Separate detector bias pin can be used for receive power monitoring
- Low power dissipation
- Can drive SERDES directly
- Flex circuit interface fits all 10GB MSAs
- RoHS compliant (EU Directive on Restrictions of Hazardous Substances, 2002/95/EC)

The HFD6x80-419 uses a high-performance GaAs PIN photo-detector packaged with a transimpedance amplifier designed to meet performance requirements for 10Gbps data communication over multi-mode optical fiber at 850nm.

Applications include Ethernet, Fiber Channel and ATM protocols. The optical assembly is designed to interface either 50 $\mu$ m or 62.5 $\mu$ m multi-mode fiber.

The HFD6x80-419 is designed to be paired with Advanced Optical Components HFE6x9x VCSEL 10Gbps TOSA products (see data sheets for HFE6x9x products at [www.finisar.com/aoc.php](http://www.finisar.com/aoc.php)).



LC ROSA



SC ROSA

Part Number	Description
HFD6180-419	LC ROSA, with flex. Low gain, non-inverting.
HFD6380-419	SC ROSA, with flex. Low gain, non-inverting.

## ABSOLUTE MAXIMUM RATINGS

Parameter	Rating
Storage temperature	-40°C to +95°C
Case operating temperature	-20°C to +95°C
Lead solder temperature	260°C, 10 seconds
Power Supply Voltage	-0.3V to 3.6V
PIN Voltage	10V
Incident Optical Power	0 dBm average, +4 dBm peak
ESD Exposure (Human Body Model)	500V

**NOTICE:** Stresses greater than those listed under “Absolute Maximum Ratings” may cause permanent damage to the device. This is a stress rating only and functional operation of the device at these or any other conditions above those indicated in the operations section for extended periods of time may affect reliability.

**NOTICE:** The inherent design of this component causes it to be sensitive to electrostatic discharge (ESD). To prevent ESD-induced damage and/or degradation to equipment, take normal ESD precautions when handling this product

## ELECTRICAL-OPTICAL CHARACTERISTICS

V<sub>CC</sub> = 3.3V, AC coupled to 50Ω (100Ω differential), -20°C < T<sub>A</sub> < 95°C unless otherwise specified

Parameters	Test Condition	Symbol	Min.	Typ.	Max.	Units	Notes
Data Rate		DR			10.7	GBd	1
Input Optical Wavelength	0°C to 70°C	$\lambda_p$	830	850	870	nm	
Supply Voltage			2.97	3.3	3.63	V	
Supply Current	P <sub>R</sub> = 0μW	I <sub>CC</sub>		35	50	mA	
PD Responsivity		Resp	0.45	0.5	0.6	A/W	10
PD Bias Voltage		V <sub>PD</sub>	3.0		3.6	V	10
Optical Return Loss		ORL	12			dB	
Differential Output Voltage Swing	P <sub>R OMA</sub> = -12dBm	V <sub>O</sub> (pk-pk)	60	125	200	mV	2,3
Differential Conversion Efficiency	P <sub>R OMA</sub> = -12dBm	T	1000	2000	3000	V/W	2,3
-3dB Optical/Electrical Bandwidth	P <sub>R OMA</sub> = -12dBm	BW	7.5	9	12.3	GHz	3,4
Low Frequency -3dB Cutoff	P <sub>R</sub> = -10dBm	BW <sub>LF</sub>			90	KHz	2,3
Output Impedance		Z <sub>out</sub>	40	50	60	Ω	
Sensitivity, OMA		S		-13.5	-12	dBm	5,9
Stressed Sensitivity	Per IEEE802.3ae	S <sub>stressed</sub>		-11.5	-9	dBm	6
Rise/Fall Time	P <sub>R OMA</sub> = -12dBm, (20%-80%)	T <sub>R</sub> /T <sub>F</sub>		30	50	ps	3,7
Group Delay		GVD	-50		50	ps	
Overload Power		P <sub>OVLD AVE</sub>	0			dBm	
		P <sub>OVLD OMA</sub>	2				
Power Supply Rejection Ratio	P <sub>R</sub> = 0μW (Dark), Freq = 1000MHz	PSRR		30		dB	2,8

**NOTES**

1. The data rate can be increased to 12.5Gbps, but the sensitivity will be decreased by approximately 3dB.
2.  $P_R$  is the average optical power at the fiber face.
3.  $P_{R,OMA}$  is the peak to peak optical power at the fiber face (Optical Modulation Amplitude)

$$P_{R,OMA} = \frac{2P_R ER - 1}{ER + 1}$$

where ER is the extinction ratio (linear) of the optical source.

4. Bandwidth and Low Frequency Cutoff are measured with a small signal sinusoidal light source with -10dBm average power
5. Sensitivity is measured with an optical source with an extinction ratio of 3dB.
6. Stressed receiver sensitivity is measured with 3.5dB vertical eye closure (intersymbol interference) and with

0.3UI of jitter added. The measurement technique is defined in IEEE 802.3ae.

7. Rise/Fall times are corrected for optical source Rise/Fall times. The corrected value is calculated as the square root of the difference of the squares of the measured differential detector output and the source.
8. Value shown is with external power supply filtering.
9. For best sensitivity, a limiting amplifier may be required for operation.
10. The PD voltage must be connected to a positive 3.3V power supply (nominal).

**PINOUT**

Number	Function
1	V <sub>CC</sub>
2	CASE
3	OUTP
4	OUTN
5	CASE
6	V <sub>PD</sub>

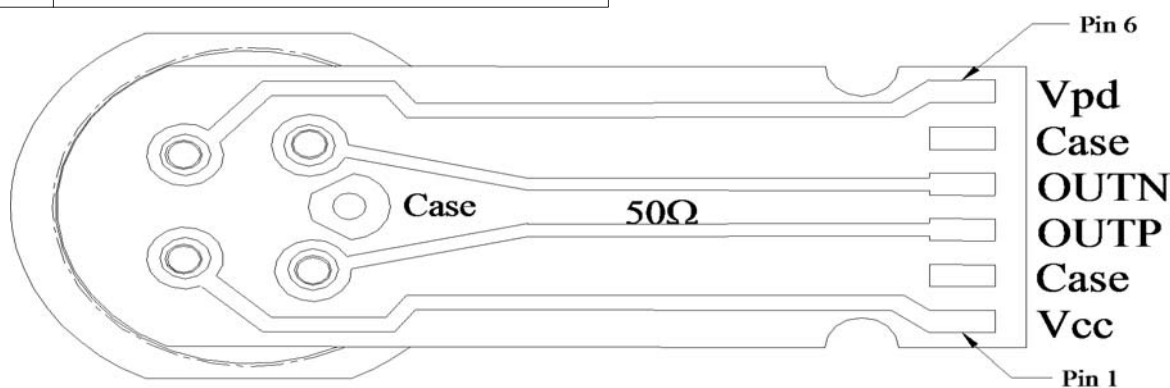

**HFD6x80-419**

## INTERFACE CONFIGURATION

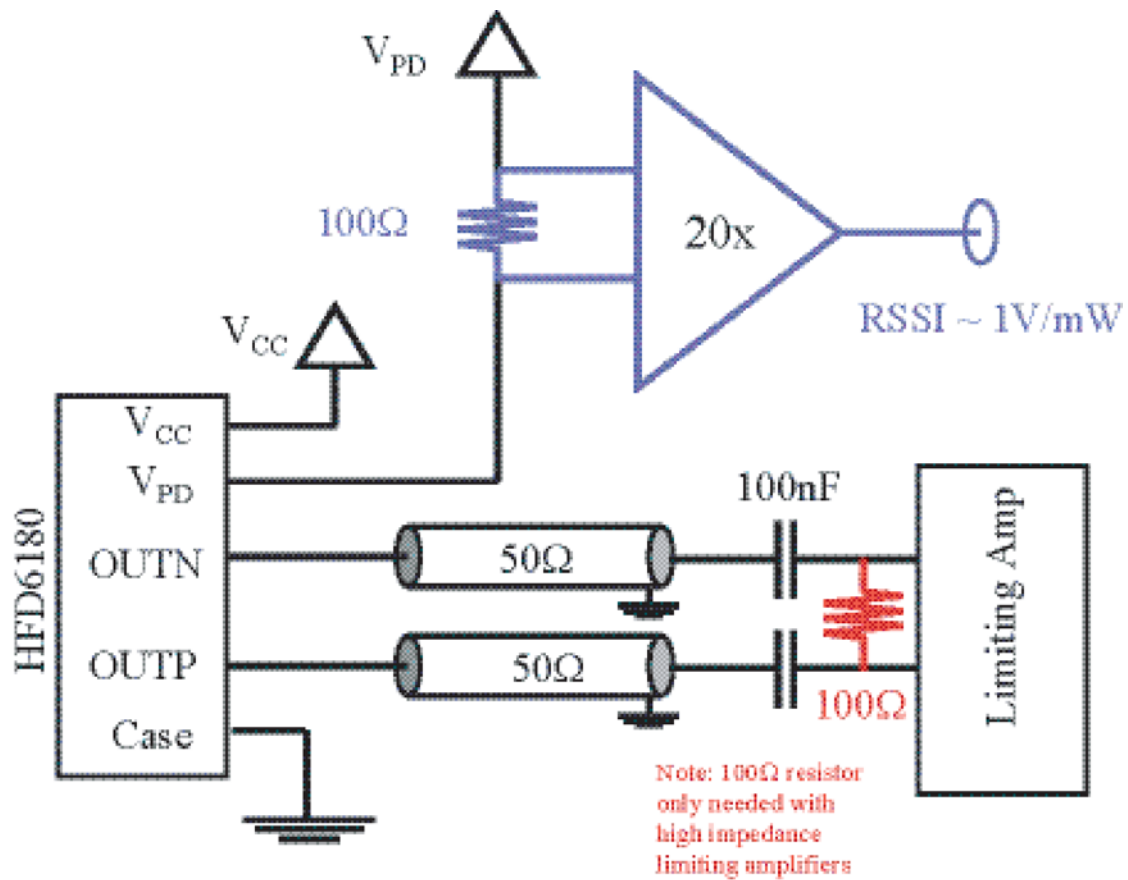

Optional RSSI implementation is shown in blue

Optional 100Ω differential termination for high impedance limiting amplifiers is shown in red.

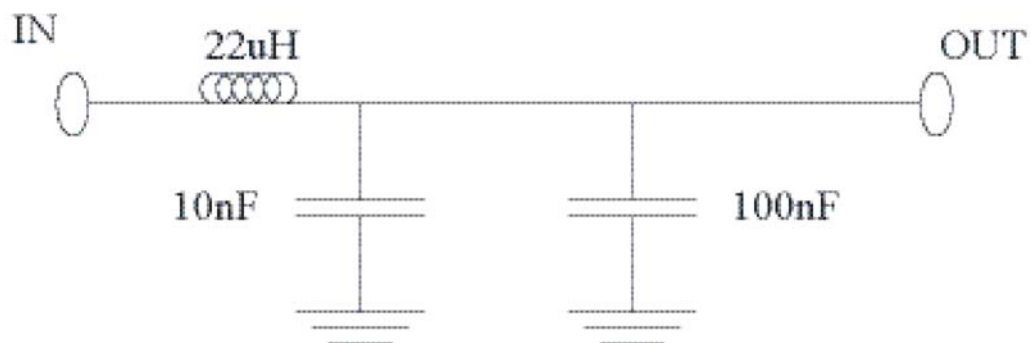

MOUNTING DIMENSIONS - LC ROSA WITH FLEX

dimensions in mm (block tolerance: dims <12 +/- .125, >12 +/- .25)

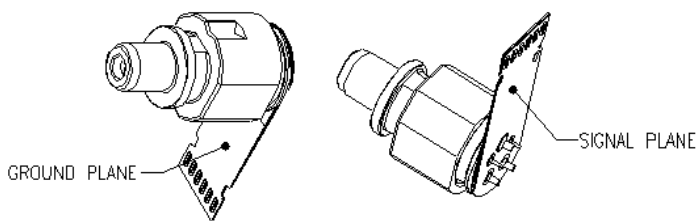
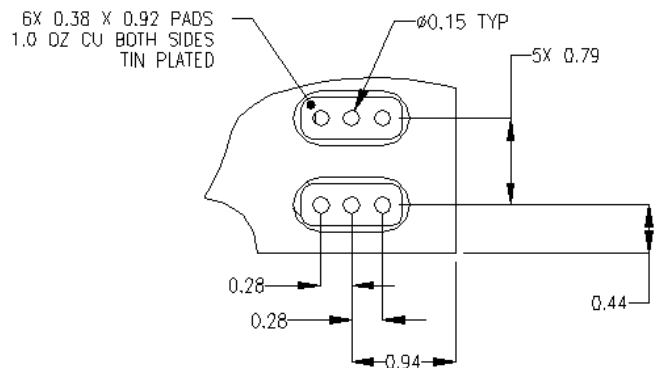
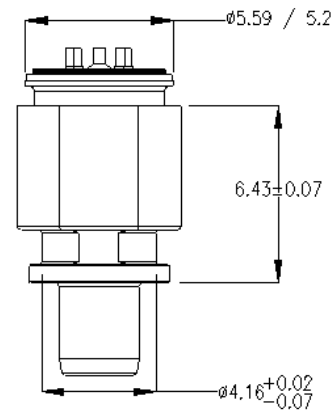
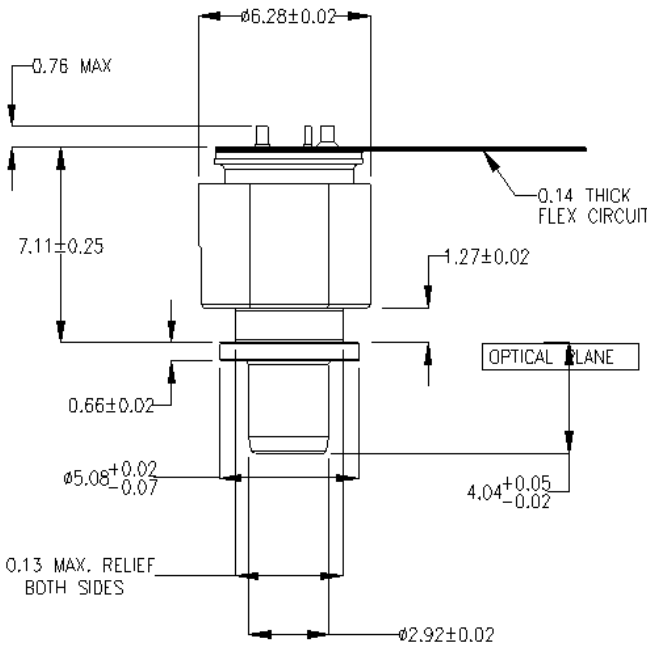
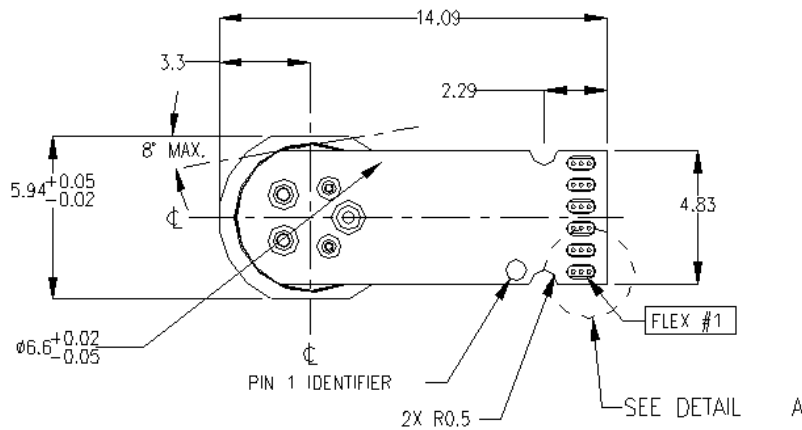

(for reference only):  
All dimensions are in inches.

MOUNTING DIMENSIONS - SC ROSA WITH FLEX

dimensions in mm (block tolerance: dims <12 +/- .125, >12 +/- .25)

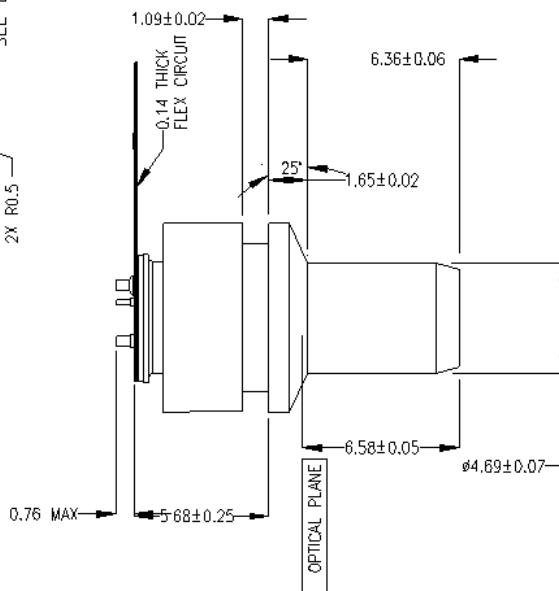
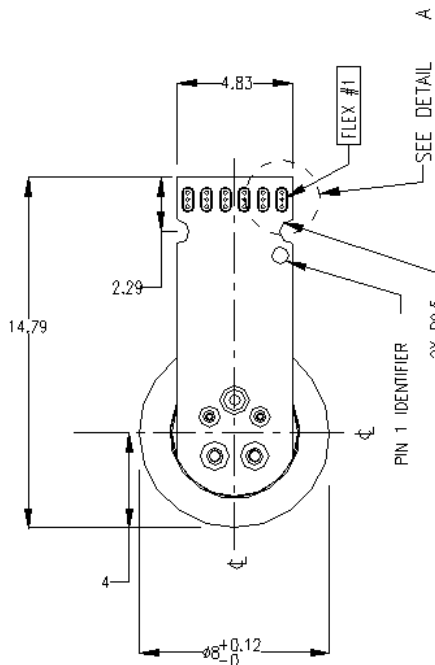
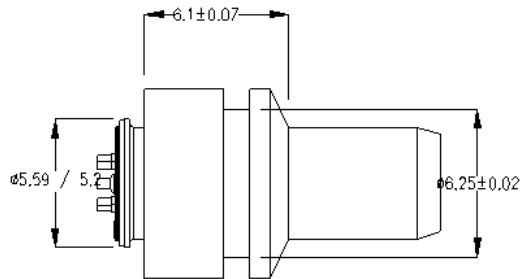
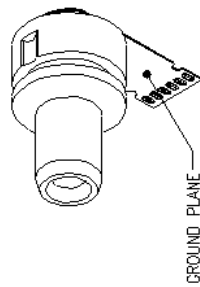
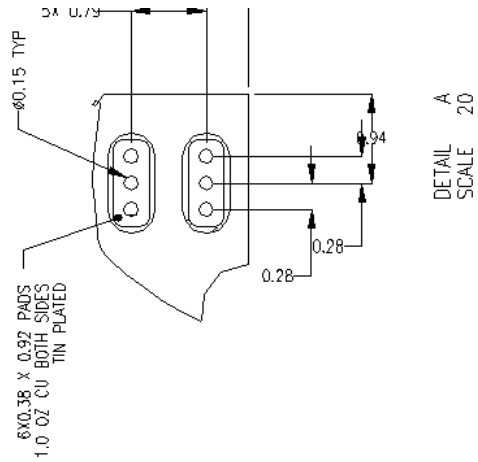

(for reference only):  
All dimensions are in inches.

## ADVANCED OPTICAL COMPONENTS

Finisar's ADVANCED OPTICAL COMPONENTS division was formed through strategic acquisition of key optical component suppliers. The company has led the industry in high volume Vertical Cavity Surface Emitting Laser (VCSEL) and associated detector technology since 1996. VCSELS have become the primary laser source for optical data communication, and are rapidly expanding into a wide variety of sensor applications. VCSELS' superior reliability, low drive current, high coupled power, narrow and circularly symmetric beam and versatile packaging options (including arrays) are enabling solutions not possible with other optical technologies. ADVANCED OPTICAL COMPONENTS is also a key supplier of Fabrey-Perot (FP) and Distributed Feedback (DFB) Lasers, and Optical Isolators (OI) for use in single mode fiber data and telecommunications networks

## LOCATION

- Allen, TX - Business unit headquarters, VCSEL wafer growth, wafer fabrication and TO package assembly.
- Fremont, CA – Wafer growth and fabrication of 1310 to 1550nm FP and DFB lasers.
- Shanghai, PRC – Optical passives assembly, including optical isolators and splitters.

## SALES AND SERVICE

Finisar's ADVANCED OPTICAL COMPONENTS division serves its customers through a worldwide network of sales offices and distributors. For application assistance, current specifications, pricing or name of the nearest Authorized Distributor, contact a nearby sales office or call the number listed below.

**Finisar**  
Advanced Optical Components Division

**Phone:** 1-866-MY-VCSEL USA (toll free)  
1-214-509-2700 USA (Direct dial)  
44 (0) 174 336 5533 Europe  
886-935-409898 China & Taiwan  
81-90-4437-1130 Japan  
82-11-220-6153 Asia Pacific & Korea

**Fax:** 1-214-509-3709 USA

Email: [support@adopco.com](mailto:support@adopco.com)  
WEB: [www.finisar.com/aoc.php](http://www.finisar.com/aoc.php)

## AOC CAPABILITIES

ADVANCED OPTICAL COMPONENTS' advanced capabilities include:

- 1, 2, 4, 8, and 10Gbps serial VCSEL solutions
- 1, 2, 4, 8, and 10Gbps serial SW DETECTOR solutions
- VCSEL and detector arrays
- 1, 2, 4, 8, and 10Gbps FP and DFB solutions at 1310 and 1550nm
- 1, 2, 4, 8, and 10Gbps serial LW DETECTOR solutions
- Optical Isolators from 1260 to 1600nm range
- Laser packaging in TO46, TO56, and Optical subassemblies with SC, LC, and MU interfaces for communication networks
- VCSELS operating at 670nm, 780nm, 980nm, and 1310nm in development
- Sensor packages include surface mount, various plastics, chip on board, chip scale packages, etc.
- Custom packaging options