

**General Description**



The ICS8305 is a low skew, 1-to-4, Differential/LVCMOS-to-LVCMOS/LVTTL Fanout Buffer and a member of the HiPerClockS™ family of High Performance Clock Solutions from IDT. The ICS8305 has selectable clock inputs that accept either differential or single ended input levels. The clock enable is internally synchronized to eliminate runt pulses on the outputs during asynchronous assertion/deassertion of the clock enable pin. Outputs are forced LOW when the clock is disabled. A separate output enable pin controls whether the outputs are in the active or high impedance state.

Guaranteed output and part-to-part skew characteristics make the ICS8305 ideal for those applications demanding well defined performance and repeatability.

**Features**

- Four LVCMOS / LVTTL outputs, 7Ω output impedance
- Selectable differential or LVCMOS / LVTTL clock inputs
- CLK, nCLK pair can accept the following differential input levels: LVPECL, LVDS, LVHSTL, HCSL, SSTL
- LVCMOS\_CLK supports the following input types: LVCMOS, LVTTL
- Maximum output frequency: 350MHz
- Output skew: 35ps (maximum)
- Part-to-part skew: 700ps (maximum)
- Additive phase jitter, RMS: 0.04ps (typical)
- Power supply modes:  
Core/Output  
3.3V/3.3V  
3.3V/2.5V  
3.3V/1.8V  
3.3V/1.5V
- 0°C to 70°C ambient operating temperature
- Available in both standard (RoHS 5) and lead-free (RoHS 6) packages

**Block Diagram**

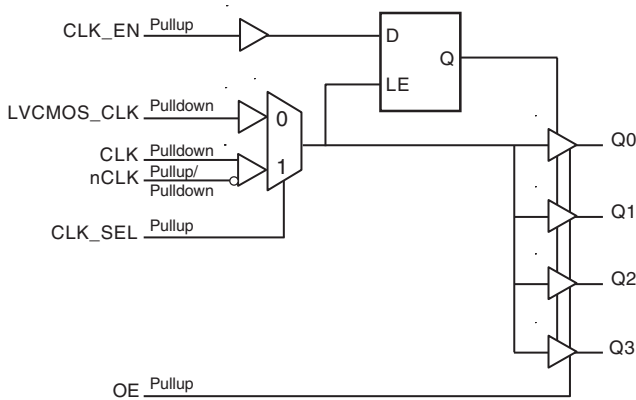

**Pin Assignment**

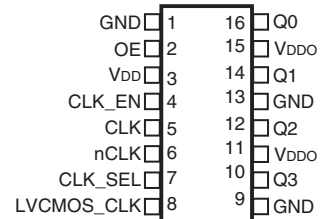

**ICS8305**

**16-Lead TSSOP**

**4.4mm x 3.0mm x 0.925mm**

**package body**

**G Package**

**Table 1. Pin Descriptions**

| Number         | Name             | Type   |                     | Description                                                                                                                                |
|----------------|------------------|--------|---------------------|--------------------------------------------------------------------------------------------------------------------------------------------|
| 1, 9, 13       | GND              | Power  |                     | Power supply ground                                                                                                                        |
| 2              | OE               | Input  | Pullup              | Output enable. When LOW, outputs are in HIGH impedance state. When HIGH, outputs are active. LVCMOS/LVTTL interface levels.                |
| 3              | V <sub>DD</sub>  | Power  |                     | Power supply pin.                                                                                                                          |
| 4              | CLK_EN           | Input  | Pullup              | Synchronizing clock enable. When LOW, the output clocks are disabled. When HIGH, output clocks are enabled. LVCMOS/LVTTL interface levels. |
| 5              | CLK              | Input  | Pulldown            | Non-inverting differential clock input.                                                                                                    |
| 6              | nCLK             | Input  | Pullup/<br>Pulldown | Inverting differential clock input. VDD/2 default when left floating.                                                                      |
| 7              | CLK_SEL          | Input  | Pullup              | Clock select input. When HIGH, selects CLK, nCLK inputs. When LOW, selects LVCMOS_CLK input. LVCMOS/LVTTL interface levels.                |
| 8              | LVCMOS_CLK       | Input  | Pulldown            | Single-ended clock input. LVCMOS/LVTTL interface levels.                                                                                   |
| 10, 12, 14, 16 | Q3, Q2, Q1, Q0   | Output |                     | Single-ended clock outputs. 7 $\Omega$ output impedance. LVCMOS/LVTTL interface levels.                                                    |
| 11, 15         | V <sub>DDO</sub> | Power  |                     | Output supply pins.                                                                                                                        |

NOTE: *Pullup* and *Pulldown* refer to internal input resistors. See Table 2, *Pin Characteristics*, for typical values.

**Table 2. Pin Characteristics**

| Symbol                | Parameter                                  | Test Conditions | Minimum | Typical | Maximum | Units      |
|-----------------------|--------------------------------------------|-----------------|---------|---------|---------|------------|
| C <sub>IN</sub>       | Input Capacitance                          |                 |         | 4       |         | pF         |
| R <sub>PULLUP</sub>   | Input Pullup Resistor                      |                 |         | 51      |         | k $\Omega$ |
| R <sub>PULLDOWN</sub> | Input Pulldown Resistor                    |                 |         | 51      |         | k $\Omega$ |
| C <sub>PD</sub>       | Power Dissipation Capacitance (per output) |                 |         | 11      |         | pF         |
| R <sub>OUT</sub>      | Output Impedance                           |                 |         | 7       |         | $\Omega$   |

## Function Tables

Table 3. Control Input Function Table

| Inputs |        |         |                 | Outputs       |
|--------|--------|---------|-----------------|---------------|
| OE     | CLK_EN | CLK_SEL | Selected Source | Q0:Q3         |
| 1      | 0      | 0       | LVC MOS_CLK     | Disabled; Low |
| 1      | 0      | 1       | CLK/nCLK        | Disabled; Low |
| 1      | 1      | 0       | LVC MOS_CLK     | Enabled       |
| 1      | 1      | 1       | CLK/nCLK        | Enabled       |
| 0      | X      | X       |                 | Hi-Z          |

After CLK\_EN switches, the clock outputs are disabled or enabled following a rising and falling input clock edge as shown in Figure 1.

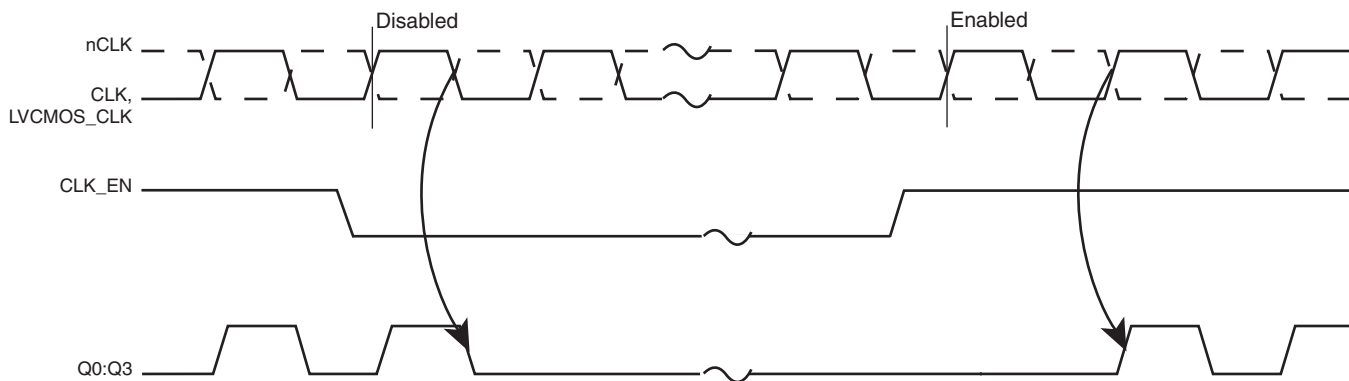

Figure 1. CLK\_EN Timing Diagram

## Absolute Maximum Ratings

NOTE: Stresses beyond those listed under *Absolute Maximum Ratings* may cause permanent damage to the device. These ratings are stress specifications only. Functional operation of product at these conditions or any conditions beyond those listed in the *DC Characteristics* or *AC Characteristics* is not implied. Exposure to absolute maximum rating conditions for extended periods may affect product reliability.

| Item                                     | Rating                    |
|------------------------------------------|---------------------------|
| Supply Voltage, $V_{DD}$                 | 4.6V                      |
| Inputs, $V_I$                            | -0.5V to $V_{DD} + 0.5V$  |
| Outputs, $V_O$                           | -0.5V to $V_{DDO} + 0.5V$ |
| Package Thermal Impedance, $\theta_{JA}$ | 89°C/W (0 lfpm)           |
| Storage Temperature, $T_{STG}$           | -65°C to 150°C            |

## DC Electrical Characteristics

**Table 4A. Power Supply DC Characteristics,  $V_{DD} = 3.3V \pm 5\%$ ,  $V_{DDO} = 3.3V \pm 5\%$  or  $2.5V \pm 5\%$  or  $1.8V \pm 0.5V$  or  $1.5V \pm 5\%$ ,  $T_A = 0^\circ\text{C}$  to  $70^\circ\text{C}$**

| Symbol    | Parameter               | Test Conditions | Minimum | Typical | Maximum | Units |
|-----------|-------------------------|-----------------|---------|---------|---------|-------|
| $V_{DD}$  | Positive Supply Voltage |                 | 3.135   | 3.3     | 3.465   | V     |
| $V_{DDO}$ | Output Supply Voltage   |                 | 3.135   | 3.3     | 3.465   | V     |
|           |                         |                 | 2.375   | 2.5     | 2.625   | V     |
|           |                         |                 | 1.65    | 1.8     | 1.95    | V     |
|           |                         |                 | 1.425   | 1.5     | 1.575   | V     |
| $I_{DD}$  | Power Supply Current    |                 |         |         | 21      | mA    |
| $I_{DDO}$ | Output Supply Current   |                 |         |         | 5       | mA    |

Table 4B. LVCMOS/LVTTL DC Characteristics,  $T_A = 0^\circ\text{C}$  to  $70^\circ\text{C}$ 

| Symbol    | Parameter                   | Test Conditions                          | Minimum                                      | Typical | Maximum        | Units         |
|-----------|-----------------------------|------------------------------------------|----------------------------------------------|---------|----------------|---------------|
| $V_{IH}$  | Input High Voltage          | CLK_EN, CLK_SEL, OE                      | 2                                            |         | $V_{DD} + 0.3$ | V             |
|           |                             | LVCMOS_CLK                               | 2                                            |         | $V_{DD} + 0.3$ | V             |
| $V_{IL}$  | Input Low Voltage           | CLK_EN, CLK_SEL, OE                      | -0.3                                         |         | 0.8            | V             |
|           |                             | LVCMOS_CLK                               | -0.3                                         |         | 1.3            | V             |
| $I_{IH}$  | Input High Current          | CLK_EN, CLK_SEL, OE                      | $V_{DD} = V_{IN} = 3.465\text{V}$            |         | 5              | $\mu\text{A}$ |
|           |                             | LVCMOS_CLK                               | $V_{DD} = V_{IN} = 3.465\text{V}$            |         | 150            | $\mu\text{A}$ |
| $I_{IL}$  | Input Low Current           | CLK_EN, CLK_SEL, OE                      | $V_{DD} = 3.465\text{V}, V_{IN} = 0\text{V}$ | -150    |                | $\mu\text{A}$ |
|           |                             | LVCMOS_CLK                               | $V_{DD} = 3.465\text{V}, V_{IN} = 0\text{V}$ | -5      |                | $\mu\text{A}$ |
| $V_{OH}$  | Output High Voltage; NOTE 1 | $V_{DDO} = 3.3\text{V} \pm 5\%$          | 2.6                                          |         |                | V             |
|           |                             | $V_{DDO} = 2.5\text{V} \pm 5\%$          | 1.8                                          |         |                | V             |
|           |                             | $V_{DDO} = 1.8\text{V} \pm 0.15\text{V}$ | 1.5                                          |         |                | V             |
|           |                             | $V_{DDO} = 1.5\text{V} \pm 5\%$          | $V_{DDO} - 0.3$                              |         |                | V             |
| $V_{OL}$  | Output Low Voltage; NOTE 1  | $V_{DDO} = 3.3\text{V} \pm 5\%$          |                                              |         | 0.5            | V             |
|           |                             | $V_{DDO} = 2.5\text{V} \pm 5\%$          |                                              |         | 0.5            | V             |
|           |                             | $V_{DDO} = 1.8\text{V} \pm 0.15\text{V}$ |                                              |         | 0.4            | V             |
|           |                             | $V_{DDO} = 1.5\text{V} \pm 5\%$          |                                              |         | 0.35           | V             |
| $I_{OZL}$ | Output Hi-Z Current Low     |                                          | -5                                           |         |                | $\mu\text{A}$ |
| $I_{OZH}$ | Output Hi-Z Current High    |                                          |                                              |         | 5              | $\mu\text{A}$ |

NOTE 1: Outputs terminated with  $50\Omega$  to  $V_{DDO}/2$ . See Parameter Measurement Information, *Output Load Test Circuit diagrams*.

Table 4C. Differential DC Characteristics,  $T_A = -40^\circ\text{C}$  to  $85^\circ\text{C}$ 

| Symbol    | Parameter                            | Test Conditions | Minimum                                      | Typical | Maximum         | Units         |
|-----------|--------------------------------------|-----------------|----------------------------------------------|---------|-----------------|---------------|
| $I_{IH}$  | Input High Current                   | nCLK            | $V_{DD} = V_{IN} = 3.465\text{V}$            |         | 150             | $\mu\text{A}$ |
|           |                                      | CLK             | $V_{DD} = V_{IN} = 3.465\text{V}$            |         | 150             | $\mu\text{A}$ |
| $I_{IL}$  | Input Low Current                    | nCLK            | $V_{DD} = 3.465\text{V}, V_{IN} = 0\text{V}$ | -150    |                 | $\mu\text{A}$ |
|           |                                      | CLK             | $V_{DD} = 3.465\text{V}, V_{IN} = 0\text{V}$ | -5      |                 | $\mu\text{A}$ |
| $V_{PP}$  | Peak-to-Peak Voltage; NOTE 1         |                 | 0.15                                         |         | 1.3             | V             |
| $V_{CMR}$ | Common Mode Input Voltage; NOTE 1, 2 |                 | GND + 0.5                                    |         | $V_{DD} - 0.85$ | V             |

NOTE 1:  $V_{IL}$  should not be less than -0.3V.

NOTE 2: Common mode input voltage is defined as  $V_{IH}$ .

## AC Electrical Characteristics

**Table 5A. AC Characteristics,  $V_{DD} = V_{DDO} = 3.3V \pm 5\%$ ,  $T_A = 0^\circ C$  to  $70^\circ C$**

| Parameter    | Symbol                                                                            | Test Conditions                                | Minimum | Typical | Maximum | Units |
|--------------|-----------------------------------------------------------------------------------|------------------------------------------------|---------|---------|---------|-------|
| $f_{MAX}$    | Output Frequency                                                                  |                                                |         |         | 350     | MHz   |
| $t_{PLH}$    | Propagation Delay, Low to High                                                    | LVCMOS_CLK;<br>NOTE 1A<br>CLK/nCLK;<br>NOTE 1B | 1.75    |         | 2.75    | ns    |
| $t_{sk(o)}$  | Output Skew; NOTE 2, 6                                                            | Measured on the Rising Edge                    |         |         | 35      | ps    |
| $t_{sk(pp)}$ | Part-to-Part Skew; NOTE 3, 6                                                      |                                                |         |         | 700     | ps    |
| $t_{jit}$    | Buffer Additive Phase Jitter, RMS; refer to Additive Phase Jitter Section, NOTE 5 |                                                |         | 0.04    |         | ps    |
| $t_R / t_F$  | Output Rise/Fall Time; NOTE 4                                                     | 20% to 80%                                     | 100     |         | 700     | ps    |
| odc          | Output Duty Cycle                                                                 | Ref = CLK/nCLK                                 | 45      |         | 55      | %     |
|              |                                                                                   | Ref = LVCMOS_CLK, $f \leq 300MHz$              | 45      |         | 55      | %     |
| $t_{EN}$     | Output Enable Time; NOTE 4                                                        |                                                |         |         | 5       | ns    |
| $t_{DIS}$    | Output Disable Time; NOTE 4                                                       |                                                |         |         | 5       | ns    |

All parameters measured at  $f \leq 350MHz$  unless noted otherwise.

NOTE 1A: Measured from the  $V_{DD}/2$  of the input to  $V_{DDO}/2$  of the output.

NOTE 1B: Measured from the differential input crossing point to  $V_{DDO}/2$  of the output.

NOTE 2: Defined as skew between outputs at the same supply voltage and with equal load conditions. Measured at  $V_{DDO}/2$ .

NOTE 3: Defined as skew between outputs on different devices operating at the same supply voltages and with equal load conditions.

Using the same type of input on each device, the output is measured at  $V_{DDO}/2$ .

NOTE 4: These parameters are guaranteed by characterization. Not tested in production.

NOTE 5: Driving only one input clock.

NOTE 6: This parameter is defined in accordance with JEDEC Standard 65.

**Table 5B. AC Characteristics,  $V_{DD} = 3.3V \pm 5\%$ ,  $V_{DDO} = 2.5V \pm 5\%$ ,  $T_A = 0^\circ C$  to  $70^\circ C$**

| Parameter    | Symbol                                                                            | Test Conditions                                | Minimum | Typical | Maximum | Units |
|--------------|-----------------------------------------------------------------------------------|------------------------------------------------|---------|---------|---------|-------|
| $f_{MAX}$    | Output Frequency                                                                  |                                                |         |         | 350     | MHz   |
| $t_{PLH}$    | Propagation Delay, Low to High                                                    | LVCMOS_CLK;<br>NOTE 1A<br>CLK/nCLK;<br>NOTE 1B | 1.8     |         | 2.9     | ns    |
| $t_{sk(o)}$  | Output Skew; NOTE 2, 6                                                            | Measured on the Rising Edge                    |         |         | 35      | ps    |
| $t_{sk(pp)}$ | Part-to-Part Skew; NOTE 3, 6                                                      |                                                |         |         | 800     | ps    |
| $t_{jit}$    | Buffer Additive Phase Jitter, RMS; refer to Additive Phase Jitter Section, NOTE 5 |                                                |         | 0.04    |         | ps    |
| $t_R / t_F$  | Output Rise/Fall Time; NOTE 4                                                     | 20% to 80%                                     | 100     |         | 700     | ps    |
| odc          | Output Duty Cycle                                                                 | Ref = CLK/nCLK                                 | 44      |         | 56      | %     |
|              |                                                                                   | Ref = LVCMOS_CLK, $f \leq 300MHz$              | 44      |         | 56      | %     |
| $t_{EN}$     | Output Enable Time; NOTE 4                                                        |                                                |         |         | 5       | ns    |
| $t_{DIS}$    | Output Disable Time; NOTE 4                                                       |                                                |         |         | 5       | ns    |

For NOTES, see Table 5A above.

**Table 5C. AC Characteristics,  $V_{DD} = 3.3V \pm 5\%$ ,  $V_{DDO} = 1.8V \pm 0.15V$ ,  $T_A = 0^\circ C$  to  $70^\circ C$** 

| Parameter    | Symbol                                                                            | Test Conditions                                | Minimum | Typical | Maximum | Units |
|--------------|-----------------------------------------------------------------------------------|------------------------------------------------|---------|---------|---------|-------|
| $f_{MAX}$    | Output Frequency                                                                  |                                                |         |         | 350     | MHz   |
| $t_{PLH}$    | Propagation Delay, Low to High                                                    | LVCMOS_CLK;<br>NOTE 1A<br>CLK/nCLK;<br>NOTE 1B | 1.95    |         | 3.65    | ns    |
| $t_{sk(o)}$  | Output Skew; NOTE 2, 6                                                            | Measured on the Rising Edge                    |         |         | 35      | ps    |
| $t_{sk(pp)}$ | Part-to-Part Skew; NOTE 3, 6                                                      |                                                |         |         | 900     | ps    |
| $t_{jit}$    | Buffer Additive Phase Jitter, RMS; refer to Additive Phase Jitter Section, NOTE 5 |                                                |         | 0.04    |         | ps    |
| $t_R / t_F$  | Output Rise/Fall Time; NOTE 4                                                     | 20% to 80%                                     | 100     |         | 700     | ps    |
| odc          | Output Duty Cycle                                                                 | Ref = CLK/nCLK                                 | 44      |         | 56      | %     |
|              |                                                                                   | Ref = LVCMOS_CLK, $f \leq 300MHz$              | 44      |         | 56      | %     |
| $t_{EN}$     | Output Enable Time; NOTE 4                                                        |                                                |         |         | 5       | ns    |
| $t_{DIS}$    | Output Disable Time; NOTE 4                                                       |                                                |         |         | 5       | ns    |

All parameters measured at  $f \leq 350MHz$  unless noted otherwise.

NOTE 1A: Measured from the  $V_{DD}/2$  of the input to  $V_{DDO}/2$  of the output.

NOTE 1B: Measured from the differential input crossing point to  $V_{DDO}/2$  of the output.

NOTE 2: Defined as skew between outputs at the same supply voltage and with equal load conditions. Measured at  $V_{DDO}/2$ .

NOTE 3: Defined as skew between outputs on different devices operating at the same supply voltages and with equal load conditions. Using the same type of input on each device, the output is measured at  $V_{DDO}/2$ .

NOTE 4: These parameters are guaranteed by characterization. Not tested in production.

NOTE 5: Driving only one input clock.

NOTE 6: This parameter is defined in accordance with JEDEC Standard 65.

**Table 5D. AC Characteristics,  $V_{DD} = 3.3V \pm 5\%$ ,  $V_{DDO} = 1.5V \pm 5\%$ ,  $T_A = 0^\circ C$  to  $70^\circ C$** 

| Parameter    | Symbol                                                                            | Test Conditions                                | Minimum | Typical | Maximum | Units |
|--------------|-----------------------------------------------------------------------------------|------------------------------------------------|---------|---------|---------|-------|
| $f_{MAX}$    | Output Frequency                                                                  |                                                |         |         | 350     | MHz   |
| $t_{PLH}$    | Propagation Delay, Low to High                                                    | LVCMOS_CLK;<br>NOTE 1A<br>CLK/nCLK;<br>NOTE 1B | 2       |         | 4       | ns    |
| $t_{sk(o)}$  | Output Skew; NOTE 2, 6                                                            | Measured on the Rising Edge                    |         |         | 35      | ps    |
| $t_{sk(pp)}$ | Part-to-Part Skew; NOTE 3, 6                                                      |                                                |         |         | 1       | ns    |
| $t_{jit}$    | Buffer Additive Phase Jitter, RMS; refer to Additive Phase Jitter Section, NOTE 5 |                                                |         | 0.04    |         | ps    |
| $t_R / t_F$  | Output Rise/Fall Time; NOTE 4                                                     | 20% to 80%                                     | 200     |         | 900     | ps    |
| odc          | Output Duty Cycle                                                                 | $f \leq 166MHz$                                | 45      |         | 55      | %     |
|              |                                                                                   | $f > 166MHz$                                   | 42      |         | 58      | %     |
| $t_{EN}$     | Output Enable Time; NOTE 4                                                        |                                                |         |         | 5       | ns    |
| $t_{DIS}$    | Output Disable Time; NOTE 4                                                       |                                                |         |         | 5       | ns    |

For NOTES, see Table 5C above.

## Additive Phase Jitter

The spectral purity in a band at a specific offset from the fundamental compared to the power of the fundamental is called the ***dBc Phase Noise***. This value is normally expressed using a Phase noise plot and is most often the specified plot in many applications. Phase noise is defined as the ratio of the noise power present in a 1Hz band at a specified offset from the fundamental frequency to the power value of the fundamental. This ratio is expressed in decibels (dBm) or a ratio of the power in the 1Hz band

to the power in the fundamental. When the required offset is specified, the phase noise is called a ***dBc*** value, which simply means dBm at a specified offset from the fundamental. By investigating jitter in the frequency domain, we get a better understanding of its effects on the desired application over the entire time record of the signal. It is mathematically possible to calculate an expected bit error rate given a phase noise plot.

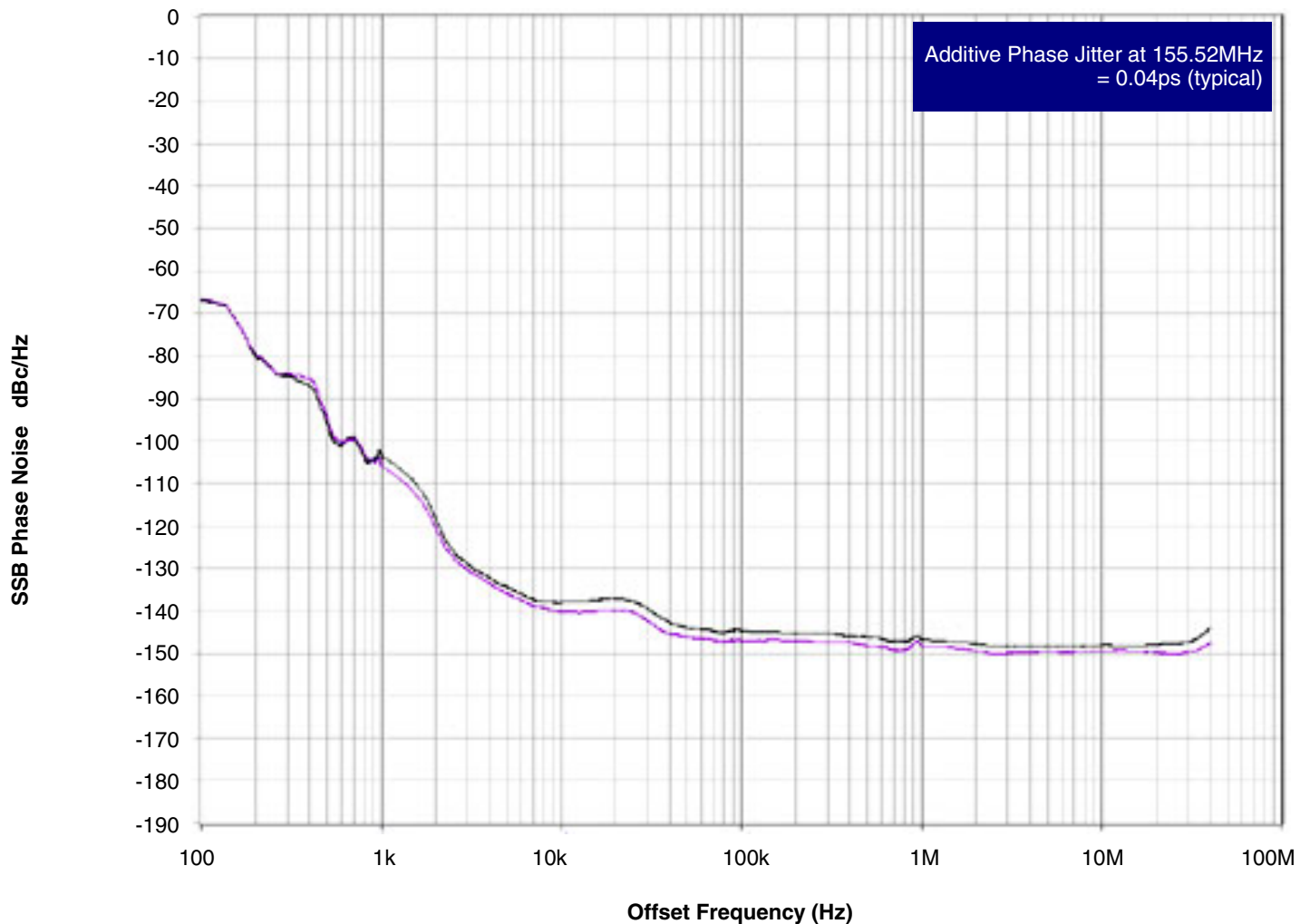

As with most timing specifications, phase noise measurements has issues relating to the limitations of the equipment. Often the noise floor of the equipment is higher than the noise floor of the

device. This is illustrated above. The device meets the noise floor of what is shown, but can actually be lower. The phase noise is dependent on the input source and measurement equipment.



### Parameter Measurement Information

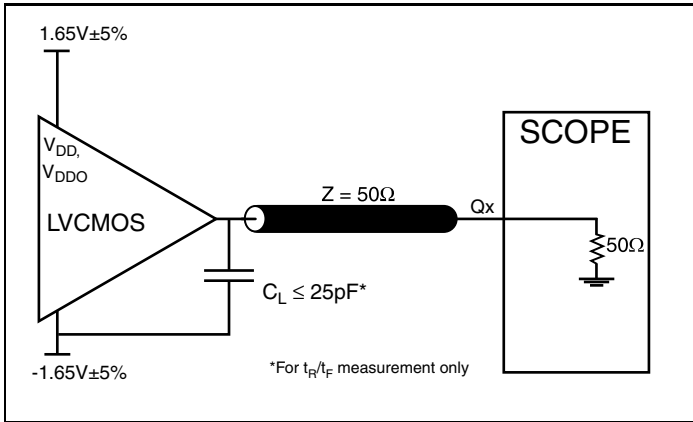

3.3V Core/3.3V LVCMOS Output Load AC Test Circuit

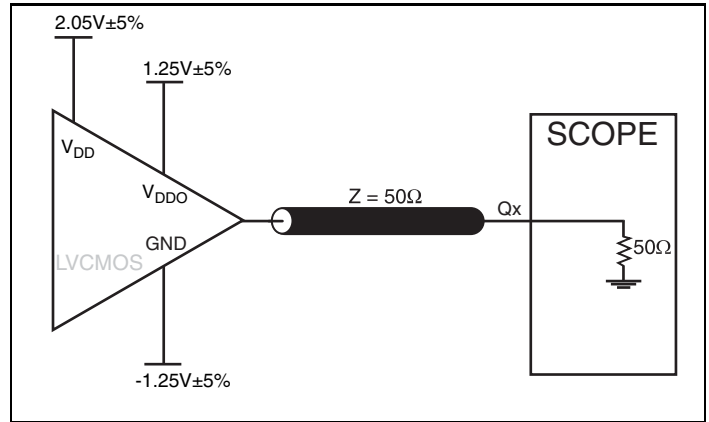

3.3V Core/2.5V LVCMOS Output Load AC Test Circuit

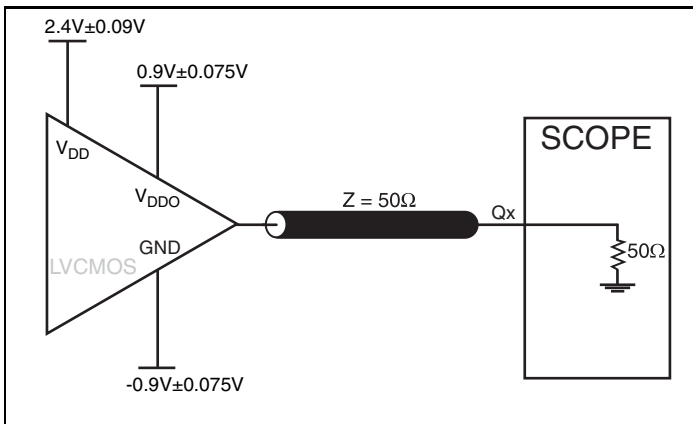

3.3V Core/1.8V LVCMOS Output Load AC Test Circuit

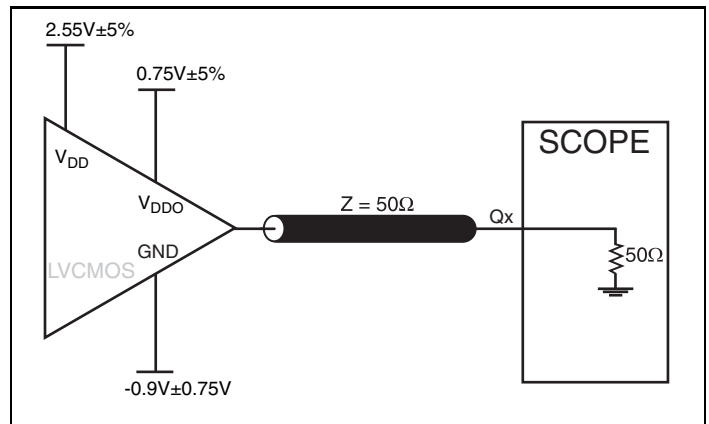

3.3V Core/1.5V LVCMOS Output Load AC Test Circuit

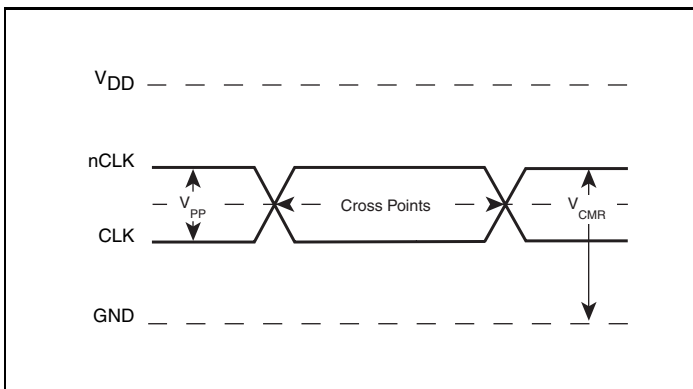

Differential Input Level

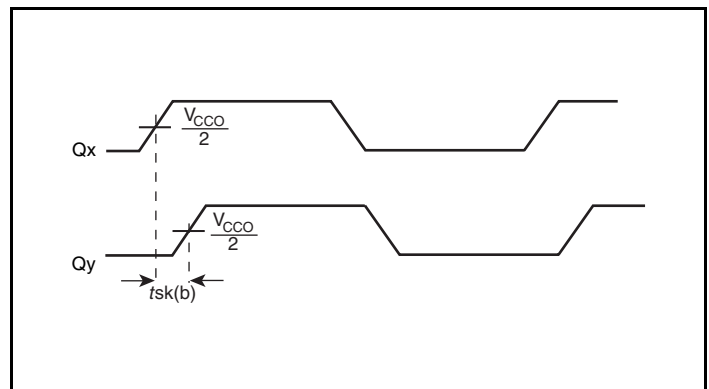

Output Skew

## Parameter Measurement Information, continued

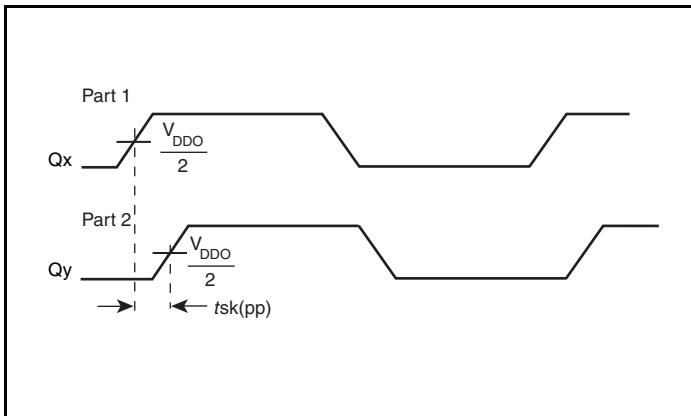

Part-to-Part Skew

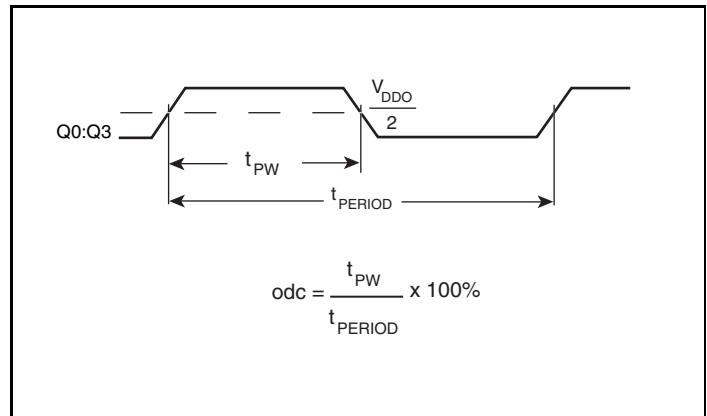

Output Duty Cycle/Pulse Width/Period

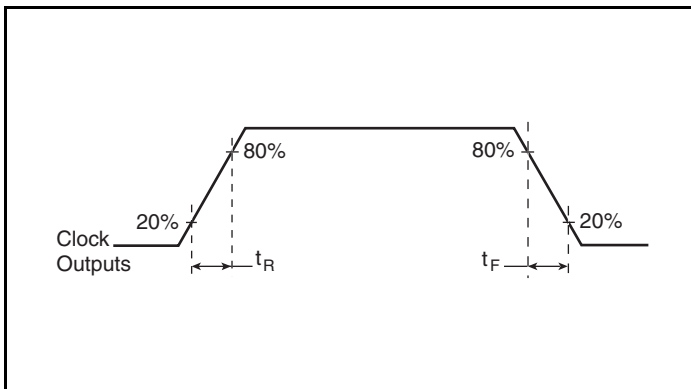

Output Rise/Fall Time

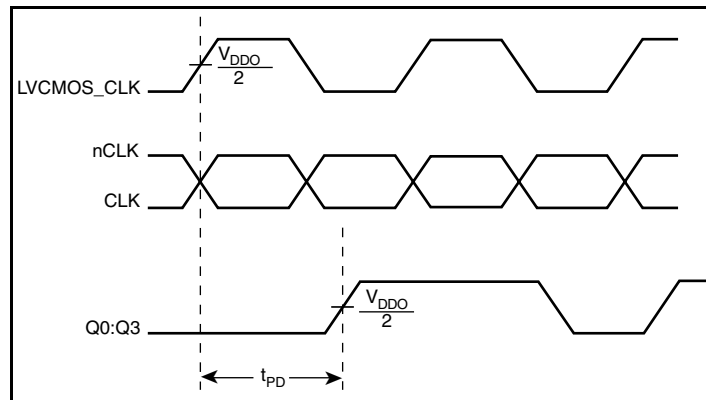

Propagation Delay

## Application Information

### Recommendations for Unused Input and Output Pins

#### Inputs:

##### LVCMOS\_CLK Input

For applications not requiring the use of a clock input, it can be left floating. Though not required, but for additional protection, a  $1\text{k}\Omega$  resistor can be tied from the LVCMOS\_CLK input to ground.

##### CLK/nCLK Inputs

For applications not requiring the use of the differential input, both CLK and nCLK can be left floating. Though not required, but for additional protection, a  $1\text{k}\Omega$  resistor can be tied from CLK to ground.

##### LVCMOS Control Pins

All control pins have internal pull-ups or pull-downs; additional resistance is not required but can be added for additional protection. A  $1\text{k}\Omega$  resistor can be used.

#### Outputs:

##### LVCMOS Outputs

All unused LVCMOS output can be left floating. There should be no trace attached.

### Wiring the Differential Input to Accept Single Ended Levels

Figure 2 shows how the differential input can be wired to accept single ended levels. The reference voltage  $V_{REF} = V_{DD}/2$  is generated by the bias resistors R1, R2 and C1. This bias circuit should be located as close as possible to the input pin. The ratio of

R1 and R2 might need to be adjusted to position the  $V_{REF}$  in the center of the input voltage swing. For example, if the input clock swing is only 2.5V and  $V_{DD} = 3.3\text{V}$ ,  $V_{REF}$  should be 1.25V and  $R2/R1 = 0.609$ .

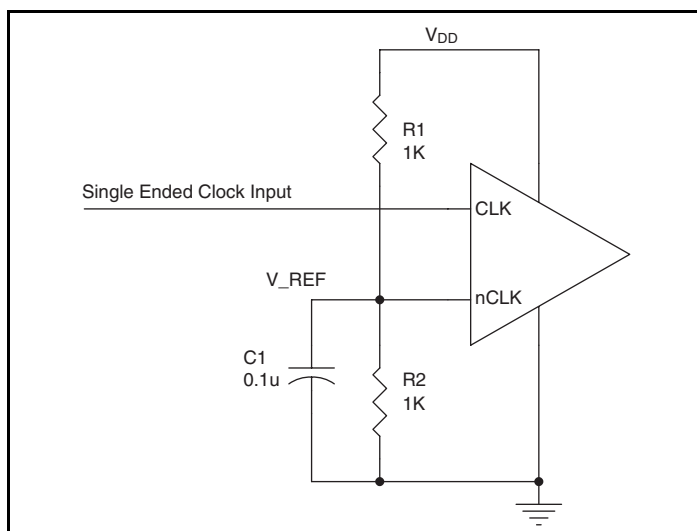
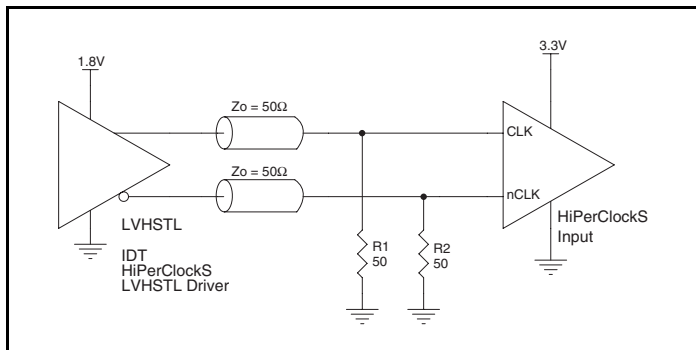

Figure 2. Single-Ended Signal Driving Differential Input

### Differential Clock Input Interface

The CLK /nCLK accepts LVDS, LVPECL, LVHSTL, SSTL, HCSL and other differential signals. Both signals must meet the  $V_{PP}$  and  $V_{CMR}$  input requirements. Figures 3A to 3F show interface examples for the HiPerClockS CLK/nCLK input driven by the most common driver types. The input interfaces suggested here are examples only. Please consult with the vendor of the driver

component to confirm the driver termination requirements. For example, in Figure 3A, the input termination applies for IDT HiPerClockS open emitter LVHSTL drivers. If you are using an LVHSTL driver from another vendor, use their termination recommendation.



**Figure 3A. HiPerClockS CLK/nCLK Input Driven by an IDT Open Emitter HiPerClockS LVHSTL Driver**

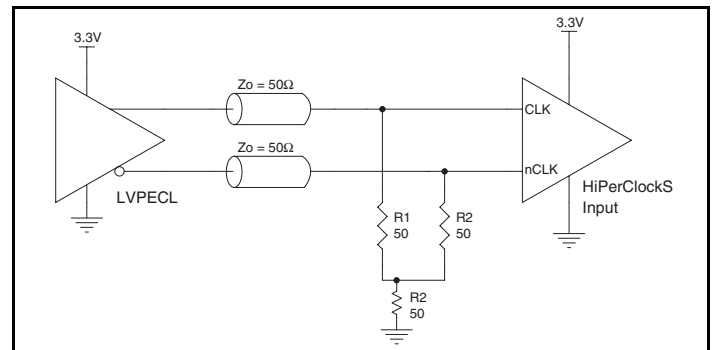

**Figure 3B. HiPerClockS CLK/nCLK Input Driven by a 3.3V LVPECL Driver**

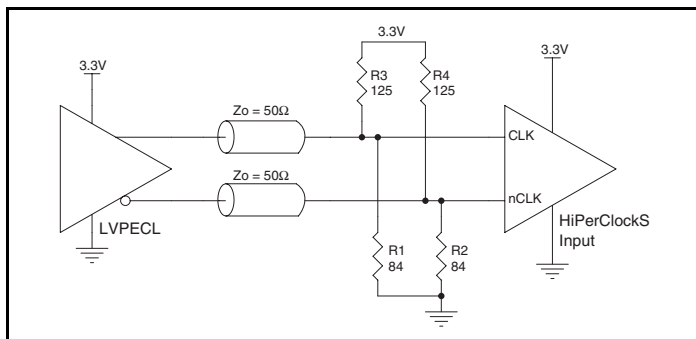

**Figure 3C. HiPerClockS CLK/nCLK Input Driven by a 3.3V LVPECL Driver**

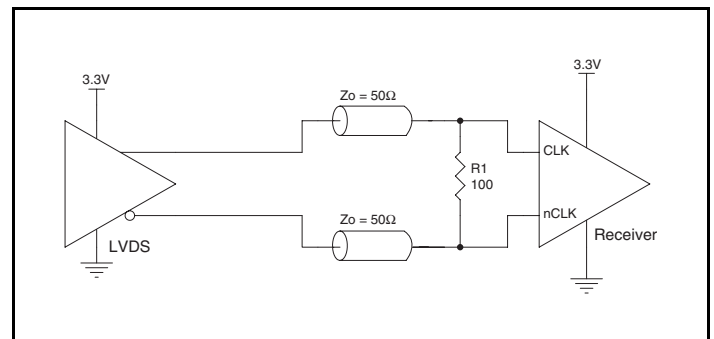

**Figure 3D. HiPerClockS CLK/nCLK Input Driven by a 3.3V LVDS Driver**

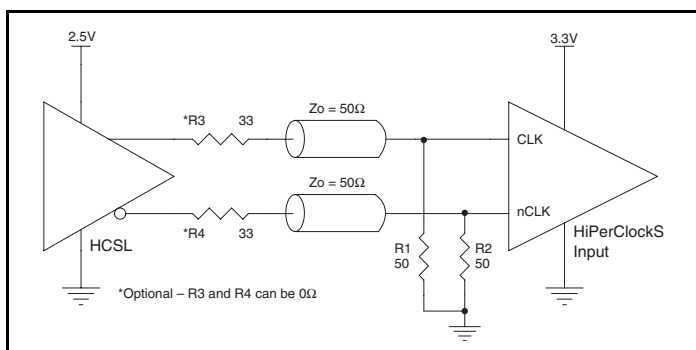

**Figure 3E. HiPerClockS CLK/nCLK Input Driven by a 3.3V HCSL Driver**

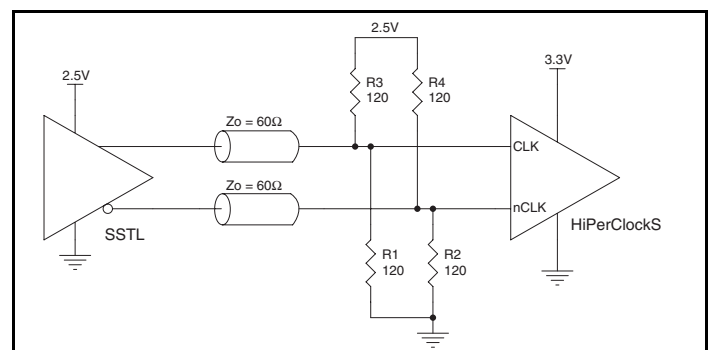

**Figure 3F. HiPerClockS CLK/nCLK Input Driven by a 2.5V SSTL Driver**

## Schematic Example

This application note provides general design guide using ICS8305 LVCMOS buffer. *Figure 4* shows a schematic example of the ICS8305 LVCMOS clock buffer. In this example, the input is

driven by an LVCMOS driver. CLK\_EN is set at logic low to select LVCMOS\_CLK input.

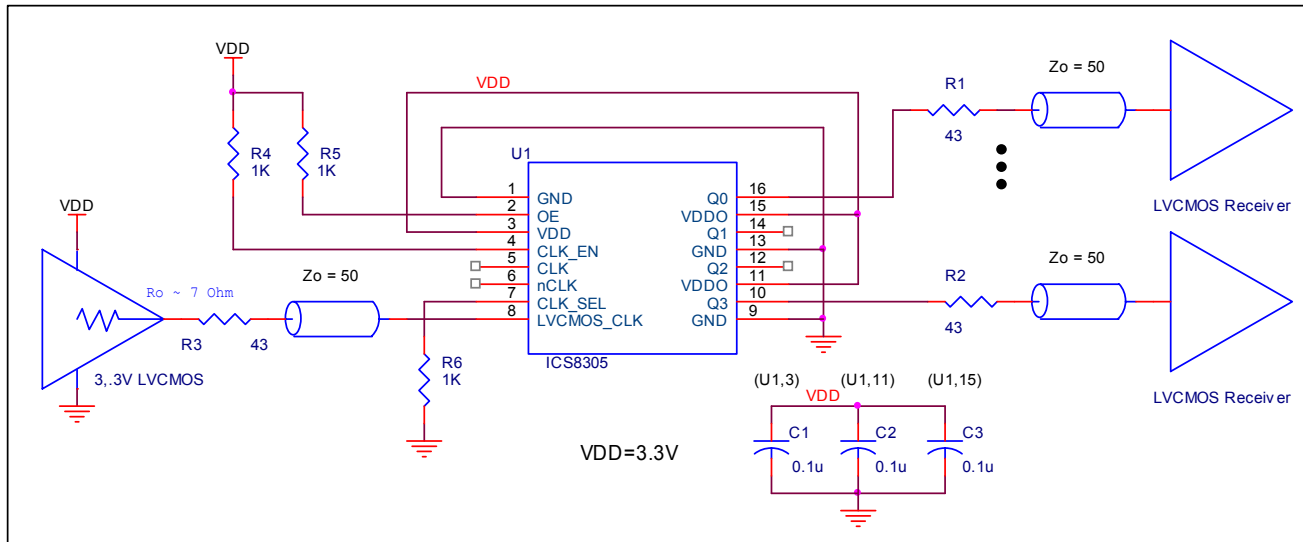

Figure 4. ICS8305 LVCMOS Clock Output Buffer Schematic Example

## Reliability Information

Table 6.  $\theta_{JA}$  vs. Air Flow Table for a 16 Lead TSSOP

| $\theta_{JA}$ vs. Air Flow                   |           |           |           |
|----------------------------------------------|-----------|-----------|-----------|
| Linear Feet per Minute                       | 0         | 200       | 500       |
| Single-Layer PCB, JEDEC Standard Test Boards | 137.1°C/W | 118.2°C/W | 106.8°C/W |
| Multi-Layer PCB, JEDEC Standard Test Boards  | 89.0°C/W  | 81.8°C/W  | 78.1°C/W  |

NOTE: Most modern PCB design use multi-layered boards. The data in the second row pertains to most designs.

## Transistor Count

The transistor count for ICS8305: 459

## Package Outline and Package Dimensions

Package Outline - G Suffix for 16 Lead TSSOP

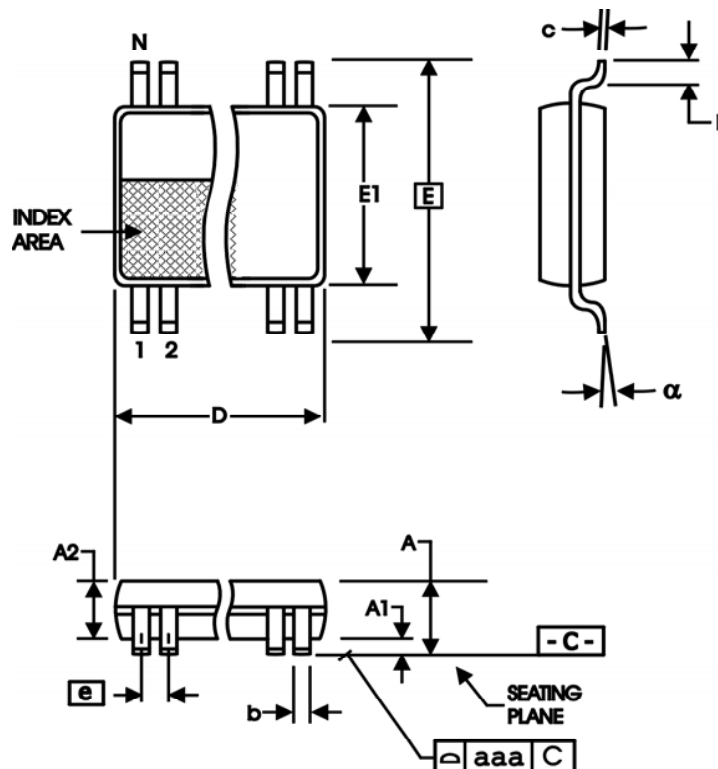

Table 7. Package Dimensions for 16 Lead TSSOP

| All Dimensions in Millimeters |            |         |
|-------------------------------|------------|---------|
| Symbol                        | Minimum    | Maximum |
| N                             | 16         |         |
| A                             |            | 1.20    |
| A1                            | 0.5        | 0.15    |
| A2                            | 0.80       | 1.05    |
| b                             | 0.19       | 0.30    |
| c                             | 0.09       | 0.20    |
| D                             | 4.90       | 5.10    |
| E                             | 6.40 Basic |         |
| E1                            | 4.30       | 4.50    |
| e                             | 0.65 Basic |         |
| L                             | 0.45       | 0.75    |
| $\alpha$                      | 0°         | 8°      |
| aaa                           |            | 0.10    |

Reference Document: JEDEC Publication 95, MO-153

## Ordering Information

Table 8. Ordering Information

| Part/Order Number | Marking  | Package                   | Shipping Packaging | Temperature |
|-------------------|----------|---------------------------|--------------------|-------------|
| ICS8305AG         | 8305AG   | 16 Lead TSSOP             | Tube               | 0°C to 70°C |
| ICS8305AGT        | 8305AG   | 16 Lead TSSOP             | 2500 Tape & Reel   | 0°C to 70°C |
| ICS8305AGLF       | 8305AGLF | "Lead-Free" 16 Lead TSSOP | Tube               | 0°C to 70°C |
| ICS8305AGLFT      | 8305AGLF | "Lead-Free" 16 Lead TSSOP | 2500 Tape & Reel   | 0°C to 70°C |

NOTE: Parts that are ordered with an "LF" suffix to the part number are the Pb-Free configuration and are RoHS compliant.

While the information presented herein has been checked for both accuracy and reliability, Integrated Device Technology (IDT) assumes no responsibility for either its use or for the infringement of any patents or other rights of third parties, which would result from its use. No other circuits, patents, or licenses are implied. This product is intended for use in normal commercial applications. Any other applications, such as those requiring extended temperature ranges, high reliability or other extraordinary environmental requirements are not recommended without additional processing by IDT. IDT reserves the right to change any circuitry or specifications without notice. IDT does not authorize or warrant any IDT product for use in life support devices or critical medical instruments.

## Revision History Sheet

| Rev | Table     | Page       | Description of Change                                                                                              | Date     |
|-----|-----------|------------|--------------------------------------------------------------------------------------------------------------------|----------|
| A   | T8        | 14         | Ordering Information table - corrected Part/Order Number typo from ICS88305AGT to ICS8305AGT.                      | 1/20/04  |
| B   | T5A - T5C | 5 & 6<br>7 | Added Additive Phase Jitter to AC Characteristics Tables.<br>Added Additive Phase Jitter Section.                  | 2/26/04  |
| B   | T1        | 2          | Pin Description Table - corrected CLK_EN description.                                                              | 12/6/04  |
| C   |           | 1          | Features Section - added 1.5V output to Supply Mode bullet and added Lead-Free bullet.                             | 11/17/05 |
|     | T4A       | 4          | Power Supply DC Characteristics Table - added $V_{DDO}$ 1.5V.                                                      |          |
|     | T4B       | 4          | LVCMOS DC Characteristics Table - added $V_{OH}/V_{OL}$ 1.5V.                                                      |          |
|     | T5D       | 7          | Added 3.3V/1.5V AC Characteristics Table.                                                                          |          |
|     |           | 10         | Added 3.3V/1.5V Output Load AC Test Circuit Drawing.                                                               |          |
|     |           | 11         | Added Recommendations for Unused Input and Output Pins.                                                            |          |
|     | T8        | 16         | Added Lead-Free part number.                                                                                       |          |
| C   | T8        | 15         | Ordering Information Table - added lead-free marking.<br>Corrected non-lead free marking from ICS8305AG to 8305AG. | 2/22/08  |



Innovate with IDT and accelerate your future networks. Contact:

**www.IDT.com**

**For Sales**

800-345-7015  
408-284-8200  
Fax: 408-284-2775

**For Tech Support**

netcom@idt.com  
480-763-2056

**Corporate Headquarters**

Integrated Device Technology, Inc.  
6024 Silver Creek Valley Road  
San Jose, CA 95138  
United States  
800 345 7015  
+408 284 8200 (outside U.S.)

**Asia**

Integrated Device Technology  
IDT (S) Pte. Ltd.  
1 Kallang Sector, #07-01/06  
Kolam Ayer Industrial Park  
Singapore 349276  
+65 67443356  
Fax: +65 67441764

**Japan**

NIPPON IDT KK  
Sanbancho Tokyu, Bld. 7F,  
8-1 Sanbancho  
Chiyoda-ku, Tokyo 102-0075  
+81 3 3221 9822  
Fax: +81 3 3221 9824

**Europe**

IDT Europe, Limited  
321 Kingston Road  
Leatherhead, Surrey  
KT22 7TU  
England  
+44 (0) 1372 363 339  
Fax: +44 (0) 1372 37885  
idteurope@idt.com

