

PCI 6150 Key Features

- ◆ Asynchronous PCI Bridging
- ◆ 25MHz to 66MHz Bus Speeds
- ◆ Large 1K Byte FIFO
- ◆ 17 x 17 mm Small BGA Package
- ◆ PQFP Package Option
- ◆ Lead Free
- ◆ Pin Compatible with 21150

Other Important Features

- ◆ 3.3V signaling, including 5V input signal tolerance
- ◆ Supports delayed transactions for PCI configuration, I/O and memory read commands
- ◆ Hot Swap friendly
- ◆ Zero wait state burst
- ◆ Provides memory write data buffering in both directions
- ◆ Provides concurrent primary and secondary bus operation to isolate traffic
- ◆ Provides separate arbitration support for individual secondary port
- ◆ Programmable 2-level arbiter
- ◆ Enhanced address decoding
- ◆ 32-bit I/O and memory address decoding
- ◆ Three-stating of I/O during power up and power down



Application:

Medical Imaging System

PLX Product:

PCI 6150 – 32-bit FastLane PCI Bridge

Key Benefit:

Consolidates Multi-Rate Bus Signals Using Asynchronous Bridging

PCI-Based Medical Imaging Systems Use Multiple Bus Rate Signals

Medical imaging systems combine high-speed imaging signals and low-speed system control signals in the same system. For example, the



control signals use 25MHz PCI signaling, and the image capture processors require 66MHz PCI to get the high resolution required in today's systems. If the 25MHz signals

are placed on the main bus, then the 66MHz signals will be forced to "fall back" to 25MHz, thereby downgrading system performance. A PCI bus will always run at the speed of the slowest device attached to the bus.



The PCI 6150 Bridges from 25MHz thru 66MHz

The traditional Intel PCI-to-PCI bridges do not have asynchronous bridging, and hence are not able to address this application.

The solution is an asynchronous *FastLane*[™] Bridge from PLX. The PCI 6150 allows 25MHz control plane signals to connect to the same system bus as the 66MHz imaging signals without dragging the bus (and hence system performance) down to the lower frequency range.

Here's How It Works

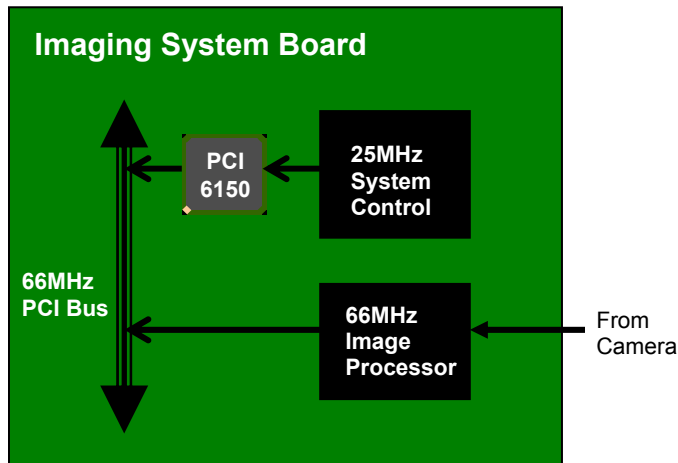

The PCI 6150 bridges the low frequency control signals (25MHz) to the high-speed system bus (66MHz). This way the system performance is maintained without dragging the bus down to accommodate the 25MHz control processor.

The Small Footprint

The PCI 6150 features a footprint of only 17 mm x 17 mm. This makes the 6150 ideal for low-profile PCI cards and other PCI cards that have board space limitations. It is also available in a PQFP version.



Lead-Free Packaging NOW!

Both the Tiny BGA and PQFP versions are available in lead-free, RoHS-compliant versions as well as the traditional leaded packages.

PLX Advantages

- Asynchronous Bridging 25MHz to 66MHz
- Largest FIFO (1024 Byte) of any 32-bit bridge
- EEPROM support for custom configuration

Design Tools & Documentation: On PLX Public ToolBox:

http://www.plxtech.com/products/fastlane_bridges/PCI6150/default.asp

- Data Book, IBIS Models, Application Notes, Product Brief, Hspice Models

Part Number	Package
PCI 6150-BB66PC	Standard Leaded PQFP Package
PCI 6150-BB66PC G	Lead-Free RoHS Green PQFP Packaging
PCI 6150-BB66BC	Standard Leaded BGA Package
PCI 6150-BB66BC G	Lead-Free RoHS Green PQFP Packaging

Contact Information

PLX Technology, Inc.
870 Maude Ave.
Sunnyvale, CA 94085 USA
Tel: 1-800-759-3735
Tel: 1-408-774-9060
Fax: 1-408-774-2169
Applications Support: Local FAE
Product Marketing:
Steve Moore smoore@plxtech.com
Web Site: www.plxtech.com

© 2005 PLX Technology, Inc. All rights reserved. PLX and the PLX logo are registered trademarks of PLX Technology, Inc. FastLane, ExpressLane, PowerDrive and the PowerDrive logo are trademarks of PLX Technology, Inc., which may be registered in some jurisdiction. All other product names that appear in this material are for identification purposes only and are acknowledged to be trademarks or registered trademarks of their respective companies. Information supplied by PLX is believed to be accurate & reliable, but PLX Technology, Inc. assumes no responsibility for any errors that may appear in this material. PLX Technology, Inc. reserves the right, without notice, to make changes in product design or specification.

6150-Med-Image-EA-1.0