

10 9 8 7 6 5 4 3 2 1

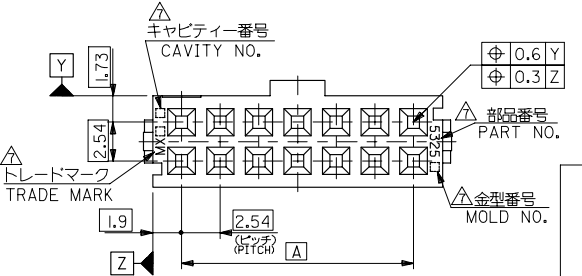
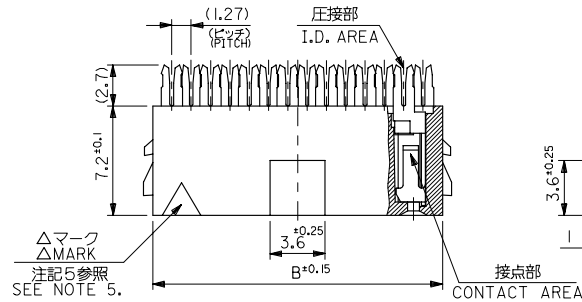
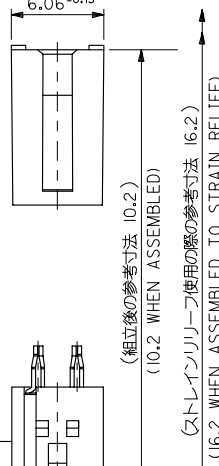
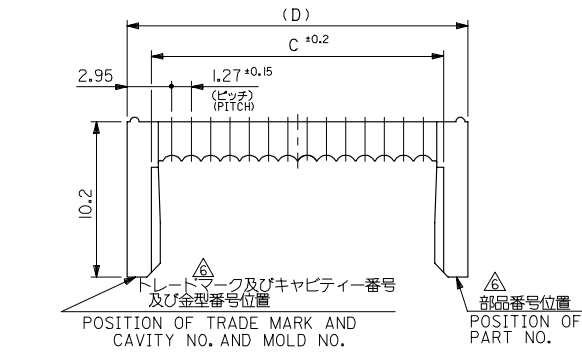

コード: CODE:	△マークの MARK COLOR	接点部メッキ CONTACT AREA PLATE	圧接部メッキ I.D. AREA PLATE	下地メッキ UNDER PLATE
LEAD FREE G1	白 WHITE	金 GOLD	0.1μm MIN.	金 GOLD 0.1μm MIN.
LEAD FREE G2	橙 ORANGE	金 GOLD	0.76μm MIN.	
LEAD FREE G3	緑 GREEN	金 GOLD	0.25μm MIN.	
LEAD FREE G4	黄 YELLOW	金 GOLD	0.1μm MIN.	
LEAD FREE GS1	黄 YELLOW	金 GOLD	0.1μm MIN.	半田 TIN-LEAD 1μm MIN.
LEAD FREE GS2	茶 BROWN	金 GOLD	0.76μm MIN.	
LEAD FREE GS3	青 BLUE	金 GOLD	0.25μm MIN.	
LEAD FREE GS4	金 GOLD	金 GOLD	1.27μm MIN.	ニッケル NICKEL 1μm MIN.
LEAD FREE GS17F	黄 YELLOW	金 GOLD	0.1μm MIN.	
LEAD FREE GS27F	茶 BROWN	金 GOLD	0.76μm MIN.	
LEAD FREE GS37F	青 BLUE	金 GOLD	0.25μm MIN.	
LEAD FREE GS47F	金 GOLD	金 GOLD	1.27μm MIN.	錫 TIN 1μm MIN.
LEAD FREE T2	黒 BLACK	錫 TIN	0.9μm MIN.	
		リフロー処理 (熱メッキ) REFLOW (PRE-PLATED)		

60	73.66	77.46	77.63	80.83
50	60.96	64.76	64.93	68.13
40	48.26	52.06	52.23	55.43
34	40.64	44.44	44.61	47.81
30	35.56	39.36	39.53	42.73
26	30.48	34.28	34.45	37.65
20	22.86	26.66	26.83	30.03
16	17.78	21.58	21.75	24.95
14	15.24	19.04	19.21	22.41
10	10.16	13.96	14.13	17.33
極数 No. of	A 寸法 DIM.A	B 寸法 DIM.B	C 寸法 DIM.C	D 寸法 DIM.D

REVISED EC NO. J2006-0712 DRAWN: YAMAGI MOTO 2005/10/03 CHKD: HANAKA 2005/10/06 APPR: NUKITA 2005/10/14	GENERAL TOLERANCES (UNLESS SPECIFIED)		DIMENSION STYLE MM ONLY		SCALE 4:1	DESIGN UNITS METRIC	THIRD ANGLE PROJECTION
	10 UNDER	±0.2	DRAWN BY SMATSUZAKI	DATE 1997/04/23	TITLE GIK FLECS FEMALE ASSY		
	10 OVER 30 UNDER	±0.25	CHECKED BY KTOJO	DATE 1997/10/13	MOLEX INCORPORATED		
	30 OVER	±0.3	APPROVED BY MFUKUSHIMA	DATE 1997/10/13	DOCUMENT NO. SD-5320-001		
ANGULAR ±3 °		DRAFT WHERE APPLICABLE MUST REMAIN WITHIN DIMENSIONS		MATERIAL NO. SEE SHEET 2 OF 2		SHEET NO. 1 OF 2	
SIZE A3				THIS DRAWING CONTAINS INFORMATION THAT IS PROPRIETARY TO MOLEX INCORPORATED AND SHOULD NOT BE USED WITHOUT WRITTEN PERMISSION			

10 9 8 7 6 5 4 3 2 1

注記 NOTES
 1. 材料 ハウジング : ガラス繊維 15% 入り PBTP (UL94V-0), 黒色
 TERMINAL : PHOS.BRO.
 2. 適用規格 : IEC 60320-1 (5%G.F.), UL94V-0, BLACK
 3. 適合ストレーンリリーフ : 5328-N
 MATES WITH STRAIN RELIEF OF 5328 SERIES

4. 適合相手 : 5330, 5332, 5340, 5342 シリーズ
 MATES WITH CONNECTOR SERIES OF 5330, 5332, 5340 & 5342

5. 使用符号の説明 LEGEND 5320-N-A-M-
 BASE NUMBER
 CIRCUIT SIZE
 プラチングの色
 MATERIAL COLOR
 BLANK : BLACK
 GY : GRAY

△ トレードマーク : MX プラス 1 文字の製造工場を示すアルファベットにて構成
 例 : J * は JAPAN を示す。(例 MX J)
 キャビティ番号 : 1桁の数字で表示
 金型番号 : アルファベット 1 文字にて構成
 部品番号 : 5327 と表示
 FORMED BY MX AND 1 MORE LETTER OF ALPHABET WHICH MEAN THE MANUFACTORY, BUT 'J' MEANS JAPAN. (TO TRADE MARK) (e.g. MXJ)
 AND BY 1 DIGIT NUMBER (TO CAVITY NO.)
 AND BY 1 LETTER OF ALPHABET (TO MOLD NO.)
 PART NO. : INDICATE 5327
 INDICATE THE SAME △, OTHERWISE ENG. NO.

39-53-5641	5320-64AGS37F-GY	39-53-5640	5320-64AGS27F-GY	39-53-4649	5320-64AGS17F-GY			39-53-3644	5320-64AGS37F	39-53-4647	5320-64AGS27F	39-53-4646	5320-64AGS17F	64
▲-5601	▲-60AGS37F-GY	▲-5600	▲-60AGS27F-GY	▲-4609	▲-60AGS17F-GY			▲-3604	▲-60AGS37F	▲-4607	▲-60AGS27F	▲-4606	▲-60AGS17F	60
▲-5501	▲-50AGS37F-GY	▲-5500	▲-50AGS27F-GY	▲-4509	▲-50AGS17F-GY	39-53-4508	5320-50AGS47F	▲-3504	▲-50AGS37F	▲-4507	▲-50AGS27F	▲-4506	▲-50AGS17F	50
								▲-3444	▲-44AGS37F					44
▲-5201	▲-40AGS37F-GY	▲-5200	▲-40AGS27F-GY	▲-4209	▲-40AGS17F-GY			▲-3204	▲-40AGS37F	▲-4207	▲-40AGS27F	▲-4206	▲-40AGS17F	40
▲-5341	▲-34AGS37F-GY	▲-5340	▲-34AGS27F-GY	▲-4349	▲-34AGS17F-GY		▲-4348	▲-34AGS47F	▲-3344	▲-34AGS37F	▲-4347	▲-34AGS27F	▲-34AGS17F	34
▲-5301	▲-30AGS37F-GY	▲-5300	▲-30AGS27F-GY	▲-4309	▲-30AGS17F-GY			▲-3304	▲-30AGS37F	▲-4307	▲-30AGS27F	▲-4306	▲-30AGS17F	30
▲-5281	▲-26AGS37F-GY	▲-5280	▲-26AGS27F-GY	▲-4289	▲-26AGS17F-GY		▲-4288	▲-26AGS47F	▲-3264	▲-26AGS37F	▲-4287	▲-26AGS27F	▲-26AGS17F	26
▲-5201	▲-20AGS37F-GY	▲-5200	▲-20AGS27F-GY	▲-4209	▲-20AGS17F-GY			▲-3204	▲-20AGS37F	▲-4207	▲-20AGS27F	▲-4206	▲-20AGS17F	20
▲-5161	▲-16AGS37F-GY	▲-5160	▲-16AGS27F-GY	▲-4169	▲-16AGS17F-GY		▲-4168	▲-16AGS47F	▲-3164	▲-16AGS37F	▲-4167	▲-16AGS27F	▲-16AGS17F	16
▲-5141	▲-14AGS37F-GY	▲-5140	▲-14AGS27F-GY	▲-4149	▲-14AGS17F-GY	39-53-4148	5320-14AGS47F	▲-3144	▲-14AGS37F	▲-4147	▲-14AGS27F	▲-4146	▲-14AGS17F	14
														12
														10
39-53-5101	5320-10AGS37F-GY	39-53-5100	5320-10AGS27F-GY	39-53-4109	5320-10AGS17F-GY			39-53-3104	5320-10AGS37F	39-53-4107	5320-10AGS27F	39-53-4106	5320-10AGS17F	10
EDP NO.	ENG. NO.	EDP NO.	ENG. NO.	EDP NO.	ENG. NO.	EDP NO.	ENG. NO.	EDP NO.	ENG. NO.	EDP NO.	ENG. NO.	EDP NO.	ENG. NO.	NO. OF CKTS.
5320-NAGS37F-GY	LEAD FREE	5320-NAGS27F-GY	LEAD FREE	5320-NAGS17F-GY	LEAD FREE	5320-NAGS47F	LEAD FREE	5320-NAGS37F	LEAD FREE	5320-NAGS27F	LEAD FREE	5320-NAGS17F	LEAD FREE	
▲-7607	▲-60AGS3-GY	▲-7606	▲-60AGS2-GY	▲-7605	▲-60AGS1-GY			▲-2602	▲-60AGS3	▲-2601	▲-60AGS2	▲-2600	▲-60AGS1	60
▲-7507	▲-50AGS3-GY	▲-7506	▲-50AGS2-GY	▲-7505	▲-50AGS1-GY	39-51-8509	5320-50AGS4	▲-2502	▲-50AGS3	▲-2501	▲-50AGS2	▲-2500	▲-50AGS1	50
								▲-2422	▲-44AGS3					44
▲-7407	▲-40AGS3-GY	▲-7406	▲-40AGS2-GY	▲-7405	▲-40AGS1-GY			▲-2402	▲-40AGS3	▲-2401	▲-40AGS2	▲-2400	▲-40AGS1	40
▲-7347	▲-34AGS3-GY	▲-7346	▲-34AGS2-GY	▲-7345	▲-34AGS1-GY		▲-8349	▲-34AGS4	▲-2342	▲-34AGS3	▲-2341	▲-34AGS2	▲-34AGS1	34
▲-7307	▲-30AGS3-GY	▲-7306	▲-30AGS2-GY	▲-7305	▲-30AGS1-GY			▲-2302	▲-30AGS3	▲-2301	▲-30AGS2	▲-2300	▲-30AGS1	30
▲-7287	▲-26AGS3-GY	▲-7286	▲-26AGS2-GY	▲-7285	▲-26AGS1-GY		▲-8269	▲-26AGS4	▲-2282	▲-26AGS3	▲-2281	▲-26AGS2	▲-26AGS1	26
▲-7207	▲-20AGS3-GY	▲-7206	▲-20AGS2-GY	▲-7205	▲-20AGS1-GY			▲-2202	▲-20AGS3	▲-2201	▲-20AGS2	▲-2200	▲-20AGS1	20
▲-7167	▲-16AGS3-GY	▲-7166	▲-16AGS2-GY	▲-7165	▲-16AGS1-GY		▲-8169	▲-16AGS4	▲-2162	▲-16AGS3	▲-2161	▲-16AGS2	▲-16AGS1	16
▲-7147	▲-14AGS3-GY	▲-7146	▲-14AGS2-GY	▲-7145	▲-14AGS1-GY	39-51-8149	5320-14AGS4	▲-2142	▲-14AGS3	▲-2141	▲-14AGS2	▲-2140	▲-14AGS1	14
														12
39-51-7107	5320-10AGS3-GY	39-51-7106	5320-10AGS2-GY	39-51-7105	5320-10AGS1-GY			39-51-2102	5320-10AGS3	39-51-2101	5320-10AGS2	39-51-2100	5320-10AGS1	10
EDP NO.	ENG. NO.	EDP NO.	ENG. NO.	EDP NO.	ENG. NO.	EDP NO.	ENG. NO.	EDP NO.	ENG. NO.	EDP NO.	ENG. NO.	EDP NO.	ENG. NO.	NO. OF CKTS.
5320-NAGS3-GY		5320-NAGS2-GY		5320-NAGS1-GY		5320-NAGS4		5320-NAGS3		5320-NAGS2		5320-NAGS1		
														64
39-52-1504	5320-50AT2	39-51-0605	5320-60AG3	15-29-3602	5320-60AG2	15-29-3601	5320-60AG1							60
		▲-0505	▲-50AG3	▲-3502	▲-50AG2	▲-3501	▲-50AG1							50
▲-1404	▲-40AT2	▲-0405	▲-40AG3	▲-3402	▲-40AG2	▲-3401	▲-40AG1							44
▲-1344	▲-34AT2	▲-0345	▲-34AG3	▲-3342	▲-34AG2	▲-3341	▲-34AG1							34
▲-1304	▲-30AT2			▲-3301	▲-30AG2	▲-3300	▲-30AG1							30
▲-1264	▲-26AT2	▲-0265	▲-26AG3	▲-3262	▲-26AG2	▲-3261	▲-26AG1							26
▲-1204	▲-20AT2	▲-0205	▲-20AG3	▲-3202	▲-20AG2	▲-3201	▲-20AG1							20
▲-1164	▲-16AT2	▲-0165	▲-16AG3	▲-3162	▲-16AG2	▲-3161	▲-16AG1							16
▲-1144	▲-14AT2	▲-0145	▲-14AG3	▲-3142	▲-14AG2	▲-3141	▲-14AG1							14
▲-1124	▲-12AT2			▲-3121	▲-12AG2	▲-3120	▲-12AG1							12
39-52-1104	5320-10AT2	39-51-0105	5320-10AG3	15-29-3102	5320-10AG2	15-29-3101	5320-10AG1							10
EDP NO.	ENG. NO.	EDP NO.	ENG. NO.	EDP NO.	ENG. NO.	EDP NO.	ENG. NO.							10
5320-NAT2	LEAD FREE	5320-NAG3		5320-NAG2		5320-NAG1								

REVISED EC NO. J2006-072 DRAWN: YAMAGI MOTO 2005/10/03 CHKD: MITSUKI 2005/10/06 APPR: NIKITA 2005/10/14	GENERAL TOLERANCES (UNLESS SPECIFIED)		DIMENSION STYLE MM ONLY		SCALE 4:1	DESIGN UNITS METRIC	THIRD ANGLE PROJECTION
	10 UNDER	±0.2	DRAWN BY SMATSUZAKI	DATE 1997/04/23	TITLE QIK FLECS FEMALE ASSY		
	10 OVER 30 UNDER	±0.25	CHECKED BY KTOJO	DATE 1997/10/13	MATERIAL NO. MOLEX INCORPORATED		
	30 OVER	±0.3	APPROVED BY MFUKUSHIMA	DATE 1997/10/13	DOCUMENT NO. SD-5320-001	SHEET NO. 2 OF 2	
ANGULAR ±3 °		DRAFT WHERE APPLICABLE MUST REMAIN WITHIN DIMENSIONS		SEE CHART		THIS DRAWING CONTAINS INFORMATION THAT IS PROPRIETARY TO MOLEX INCORPORATED AND SHOULD NOT BE USED WITHOUT WRITTEN PERMISSION	

10 9 8 7 6 5 4 3 2 1

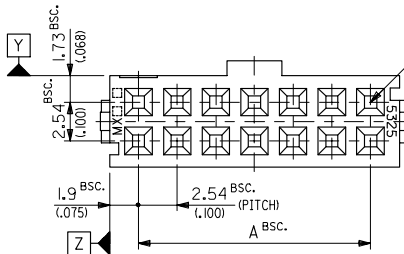
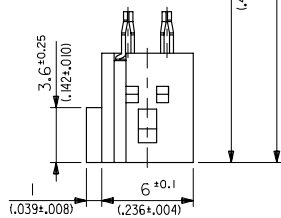
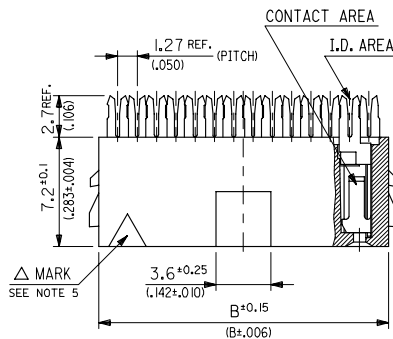
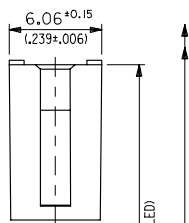
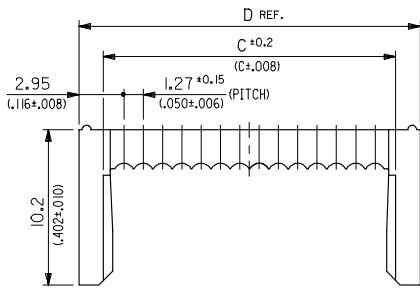

⊕ 0.6 (0.24) Y
⊕ 0.3 (0.12) Z

NOTES

- MATERIAL
HOUSING : G.F. 15% PBTP (UL94V-0)
TERMINAL : PHOSPHOR BRONZE
- FOR USE WITH AWG#26 & #28 STRANDED WIRE (CONSISTS OF 7 CONDUCTORS) AND #28 SOLID WIRE.
1.14(.045) DIA. MAX. INSULATION RIBBON CABLE WITH 1.27(.050) CENTERS.
- MATES WITH STRAIN RELIEF OF 5328 SERIES.
- MATES WITH CONNECTOR SERIES OF 5330,5332,5340,5342,5576 & 5578.
- LEGEND

5320 - N A * - *
 BASE NUMBER _____ MATERIAL COLOR _____
 CIRCUIT SIZE _____ BLANK : BLACK
 UNLOADED UPPER HOUSING _____ GY : GREY
 PLATING CODE OF TERMINAL _____

CODE : *	△MARK COLOR	CONTACT AREA PLATE	I. D. AREA PLATE	UNDER PLATE
GS1	YELLOW	GOLD 0.1μm(4μ") MIN.	TIN-LEAD 1 μm(39μ") MIN.	NICKEL 1 μm(39μ") MIN.
GS3	BLUE	GOLD 0.25μm(10μ") MIN.		
LEAD FREE GS17F	YELLOW	GOLD 0.1μm(4μ") MIN.	TIN 1 μm(39μ") MIN.	
LEAD FREE GS37F	BLUE	GOLD 0.25μm(10μ") MIN.		
LEAD FREE T2	BLACK	TIN 0.9μm(35μ") MIN. REFLOW (PRE-PLATED)	WITHOUT	WITHOUT

NO. OF CKTS.	DIM. A	DIM. B	DIM. C	DIM. D
64	78.74 (3,100)	82.54 (3,250)	82.71 (3,256)	85.91 (3,382)
60	73.66 (2,900)	77.46 (3,050)	77.63 (3,056)	80.83 (3,182)
50	60.96 (2,400)	64.76 (2,550)	64.93 (2,556)	68.13 (2,682)
40	48.26 (1,900)	52.06 (2,050)	52.23 (2,056)	55.43 (2,182)
34	40.64 (1,600)	44.44 (1,750)	44.61 (1,756)	47.81 (1,882)
30	35.56 (1,400)	39.36 (1,550)	39.53 (1,556)	42.73 (1,682)
26	30.48 (1,200)	34.28 (1,350)	34.45 (1,356)	37.65 (1,482)
20	22.86 (900)	26.66 (1,050)	26.83 (1,056)	30.03 (1,182)
16	17.78 (700)	21.58 (850)	21.75 (856)	24.95 (982)
14	15.24 (600)	19.04 (750)	19.21 (756)	22.41 (882)
12	12.70 (500)	16.50 (650)	16.67 (656)	19.87 (782)
10	10.16 (400)	13.96 (550)	14.13 (556)	17.33 (682)

REVISED EC NO. J2006-0712 DRW:YAMAGI MOTO 2005/10/03 CHK:MTANAKA 2005/10/06 APPR:NIKIITA 2005/10/14 K	GENERAL TOLERANCES (UNLESS SPECIFIED)		DIMENSION STYLE MM ONLY	SCALE 4:1	DESIGN UNITS METRIC	THIRD ANGLE PROJECTION
	10 UNDER	±0.2	DRAWN BY HHIRAMOTO	DATE 1990/07/11	TITLE QIK FLECS FEMALE ASSY ENGLISH ONLY	
	10 OVER 30 UNDER	±0.25	CHECKED BY MSASAO	DATE	MOLEX INCORPORATED	
	30 OVER	±0.3	APPROVED BY HIKESUGI	DATE	DOCUMENT NO. SD-5320-002	SHEET NO. 1 OF 2
ANGULAR ±3 °			MATERIAL NO.	SEE SHEET 2 OF 2		
DRAFT WHERE APPLICABLE MUST REMAIN WITHIN DIMENSIONS			SIZE A3	THIS DRAWING CONTAINS INFORMATION THAT IS PROPRIETARY TO MOLEX INCORPORATED AND SHOULD NOT BE USED WITHOUT WRITTEN PERMISSION		

10 9 8 7 6 5 4 3 2 1

F

E

D

C

B

A

F

E

D

C

B

A

39-52-1504	5320-50AT2	60
▲ -1404	▲ -40AT2	40
-1344	-34AT2	34
-1304	-30AT2	30
-1264	-26AT2	26
-1204	-20AT2	20
-1164	-16AT2	16
▼ -1144	▼ -14AT2	14
39-52-1104	5320-10AT2	10
EDP NO.	ENG. NO.	NO. OF CKTS.
5320-NAT2	-LEAD FREE-	

39-53-3604	5320-60AGS37F	39-51-2602	5320-60AGS3	60
▲ -3504	▲ -50AGS37F	▲ -2502	▲ -50AGS3	50
-3404	-40AGS37F	-2402	-40AGS3	40
-3344	-34AGS37F	-2342	-34AGS3	34
-3304	-30AGS37F	-2302	-30AGS3	30
-3264	-26AGS37F	-2262	-26AGS3	26
-3204	-20AGS37F	-2202	-20AGS3	20
-3164	-16AGS37F	-2162	-16AGS3	16
▼ -3144	▼ -14AGS37F	▼ -2142	▼ -14AGS3	14
39-53-3104	5320-10AGS37F	39-51-2102	5320-10AGS3	10
EDP NO.	ENG. NO.	EDP NO.	ENG. NO.	NO. OF CKTS.
5320-NAGS37F	-LEAD FREE-	5320-NAGS3		
39-53-4606	5320-60AGS17F	39-51-2600	5320-60AGS1	60
▲ -4506	▲ -50AGS17F	▲ -2500	▲ -50AGS1	50
-4406	-40AGS17F	-2400	-40AGS1	40
-4346	-34AGS17F	-2340	-34AGS1	34
-4306	-30AGS17F	-2300	-30AGS1	30
-4266	-26AGS17F	-2260	-26AGS1	26
-4206	-20AGS17F	-2200	-20AGS1	20
-4166	-16AGS17F	-2160	-16AGS1	16
▼ -4146	▼ -14AGS17F	▼ -2140	▼ -14AGS1	14
39-53-4106	5320-10AGS17F	39-51-2100	5320-10AGS1	10
EDP NO.	ENG. NO.	EDP NO.	ENG. NO.	NO. OF CKTS.
5320-NAGS17F	-LEAD FREE-	5320-NAGS1		

REVISED EC NO. J2006-0712 DRW: HAYAMOTO 2005/10/03 CHK: HATANAKA 2005/10/06 APPR: NUKITA 2005/10/14 K	GENERAL TOLERANCES (UNLESS SPECIFIED)		DIMENSION STYLE MM ONLY		SCALE 4:1	DESIGN UNITS METRIC	THIRD ANGLE PROJECTION	
	10 UNDER	± 0.2	DRAWN BY HIRAMOTO		DATE 1990/07/11	TITLE QIK FLECS FEMALE ASSY ENGLISH ONLY		
	10 OVER 30 UNDER	± 0.25	CHECKED BY MSASAO		DATE			
	30 OVER	± 0.3	APPROVED BY HIKESUGI		DATE	MOLEX INCORPORATED		
	ANGULAR	± 3 °	MATERIAL NO.		DOCUMENT NO.			
DRAFT WHERE APPLICABLE MUST REMAIN WITHIN DIMENSIONS			SEE CHART		SD-5320-002	SHEET NO. 2 OF 2		
THIS DRAWING CONTAINS INFORMATION THAT IS PROPRIETARY TO MOLEX INCORPORATED AND SHOULD NOT BE USED WITHOUT WRITTEN PERMISSION					EN-02JA(021)			

9

8

7

6

5

4

3

2

EN-02JA(021)

10 9 8 7 6 5 4 3 2 1

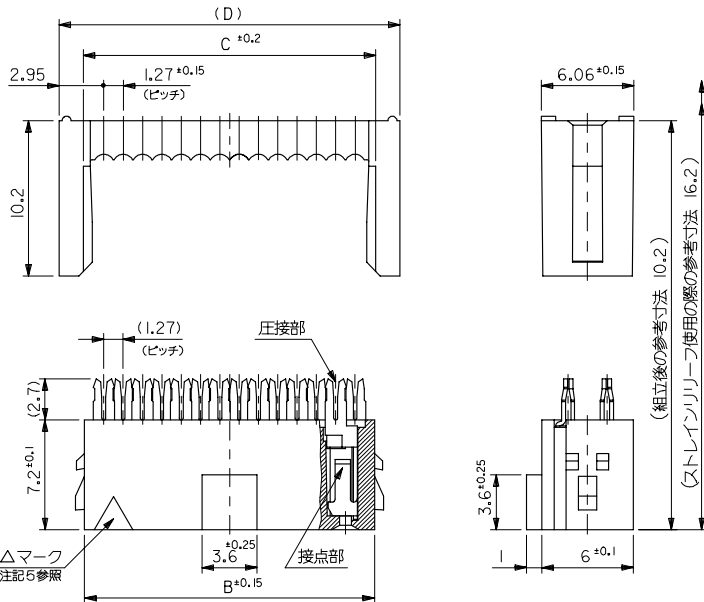

注記

- 材料 ハウジング : ガラス繊維 15% 入り PBTP (UL94V-0), 黒色
ターミナル : リン青銅
- 適用電線 : 1.27 ピッチリボンケーブル 被覆外径 : $\varnothing 1.14$ MAX.
より線 : AWG#26 ~ #28 (芯線 7 本構成)
単線 : AWG#28
- 適合ストレーンリリーフ : 5328-N
- 嵌合相手 : 5330, 5332, 5340, 5342 シリーズ
- 使用符号の説明

コード*	△マークの色	接点部メッキ	圧接部メッキ	下地メッキ
GS1	黄	金 0.1 μ m MIN.	半田 1 μ m MIN.	ニッケル
GS3	青	金 0.25 μ m MIN.		1 μ m MIN.
LEAD FREE GS17F	黄	金 0.1 μ m MIN.	錫 1 μ m MIN.	
LEAD FREE GS37F	青	金 0.25 μ m MIN.		
LEAD FREE T2	黒	錫 0.9 μ m MIN. リフロー処理 (部メッキ)		

60	73.66	77.46	77.63	80.83
50	60.96	64.76	64.93	68.13
40	48.26	52.06	52.23	55.43
34	40.64	44.44	44.61	47.81
30	35.56	39.36	39.53	42.73
26	30.48	34.28	34.45	37.65
20	22.86	26.66	26.83	30.03
16	17.78	21.58	21.75	24.95
14	15.24	19.04	19.21	22.41
10	10.16	13.96	14.13	17.33
極数	A 寸法	B 寸法	C 寸法	D 寸法

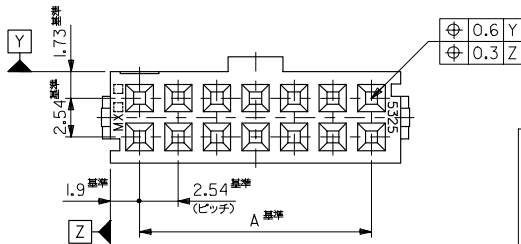

GENERAL TOLERANCES (UNLESS SPECIFIED)		DIMENSION STYLE MM ONLY		SCALE 4:1	DESIGN UNITS METRIC	THIRD ANGLE PROJECTION
10 UNDER	± 0.2	DRAWN BY H. HIRAMOTO	DATE 1990/07/10	TITLE QIK FLECS FEMALE ASSY		
10 OVER 30 UNDER	± 0.25	CHECKED BY M. SASAO	DATE			
30 OVER	± 0.3	APPROVED BY H. IKESUGI	DATE			
ANGULAR ± 3 °		MATERIAL NO.		DOCUMENT NO. SD-5320-007		
DRAFT WHERE APPLICABLE MUST REMAIN WITHIN DIMENSIONS		SEE SHEET 2 OF 2		SHEET NO. 1 OF 2		
THIS DRAWING CONTAINS INFORMATION THAT IS PROPRIETARY TO MOLEX INCORPORATED AND SHOULD NOT BE USED WITHOUT WRITTEN PERMISSION						

10 9 8 7 6 5 4 3 2 1

F

F

E

E

D

D

C

C

B

B

A

A

39-52-1504	5320-50AT2	60
▲ -1404	▲ -40AT2	40
-1344	-34AT2	34
-1304	-30AT2	30
-1264	-26AT2	26
-1204	-20AT2	20
-1164	-16AT2	16
▼ -1144	▼ -14AT2	14
39-52-1104	5320-10AT2	10
EDP NO.	ENG. NO.	極数
5320-NAT2	-LEAD FREE-	

39-53-3604	5320-60AGS37F	39-51-2602	5320-60AGS3	60
▲ -3504	▲ -50AGS37F	▲ -2502	▲ -50AGS3	50
▼ -3404	▼ -40AGS37F	-2402	-40AGS3	40
-3344	-34AGS37F	-2342	-34AGS3	34
-3304	-30AGS37F	-2302	-30AGS3	30
-3264	-26AGS37F	-2262	-26AGS3	26
-3204	-20AGS37F	-2202	-20AGS3	20
-3164	-16AGS37F	-2162	-16AGS3	16
-3144	-14AGS37F	▼ -2142	▼ -14AGS3	14
39-53-3104	5320-10AGS37F	39-51-2102	5320-10AGS3	10
EDP NO.	ENG. NO.	EDP NO.	ENG. NO.	極数
5320-NAGS37F	-LEAD FREE-	5320-NAGS3		
39-53-4606	5320-60AGS17F	39-51-2600	5320-60AGS1	60
▲ -4506	▲ -50AGS17F	▲ -2500	▲ -50AGS1	50
-4406	-40AGS17F	-2400	-40AGS1	40
-4346	-34AGS17F	-2340	-34AGS1	34
-4306	-30AGS17F	-2300	-30AGS1	30
-4266	-26AGS17F	-2260	-26AGS1	26
-4206	-20AGS17F	-2200	-20AGS1	20
-4166	-16AGS17F	-2160	-16AGS1	16
▼ -4146	▼ -14AGS17F	▼ -2140	▼ -14AGS1	14
39-53-4106	5320-10AGS17F	39-51-2100	5320-10AGS1	10
EDP NO.	ENG. NO.	EDP NO.	ENG. NO.	極数
5320-NAGS17F	-LEAD FREE-	5320-NAGS1		

REVISED EC NO. J2006-0712 DRW: HAYASHI MOTO 2005/10/03 CHK: CHIKAHARA 2005/10/06 APPR: NUKITA 2005/10/14	GENERAL TOLERANCES (UNLESS SPECIFIED)		DIMENSION STYLE MM ONLY		SCALE 4:1	DESIGN UNITS METRIC	THIRD ANGLE PROJECTION
	10 UNDER	±0.2	DRAWN BY H. HIRAMOTO	DATE 1990/07/10	TITLE QIK FLECS FEMALE ASSY		
	10 OVER 30 UNDER	±0.25	CHECKED BY M. SASAO	DATE			
	30 OVER	±0.3	APPROVED BY H. IKESUGI	DATE	MOLEX INCORPORATED		
	ANGULAR	±3 °	MATERIAL NO.	DOCUMENT NO. SD-5320-007			
DRAFT WHERE APPLICABLE MUST REMAIN WITHIN DIMENSIONS		SIZE A3	THIS DRAWING CONTAINS INFORMATION THAT IS PROPRIETARY TO MOLEX INCORPORATED AND SHOULD NOT BE USED WITHOUT WRITTEN PERMISSION				